

M-S Quad Driver X12.017

Features

- generates microsteps
- glitch filters on all inputs
- VDD = 4.5 to 5.5V
- low EMI emission

Description

The M-S Quad Driver X12.017 is a monolithic CMOS device intended to be used as an interface circuit to ease the use of the Miniature Stepper Motors M-S X15.xxx. It was specifically designed for applications in the car dashboard. The circuit allows the user to drive four motors as it contains four identical drivers on the same chip.

The driver circuit converts a pulse train $f(scx)$ into a current level sequence sent to the motor coils. This sequence is used to produce the microstepping movement of the motor. A microstep corresponds to an angular rotation of 1/12 deg. of the shaft. The microstepping allows for smooth and appealing movement of a pointer if the M-S is used as pointer drive. Note that the precision of the angular position is always affected by the gear play of the motor which is $\pm 1/3$ deg.

Applications

Analogue Instrumentation

- car dashboard (Hybrid Instrument Cluster)
- nautical instrumentation
- aeronautical instrumentation

Microrobotics

- appliance controls
- devices for medical analysis

Typical Operating Configuration

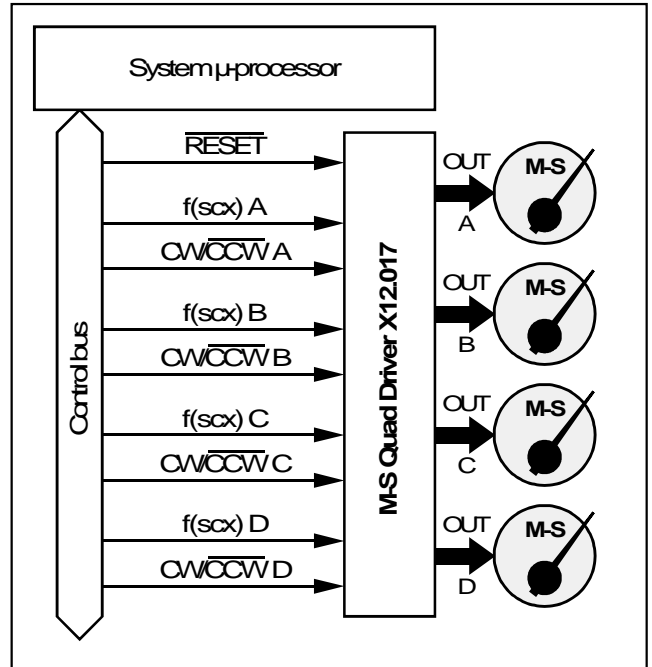

Fig. 1

Pin Assignment

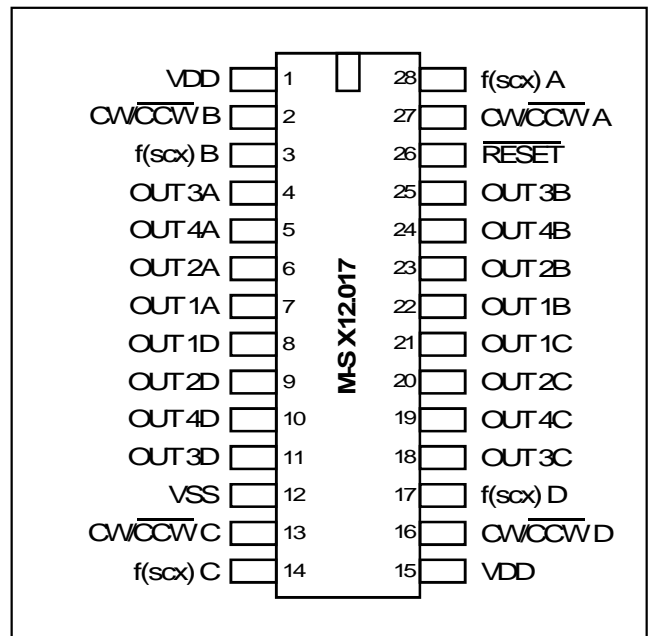

Fig. 2

Absolute Maximum Ratings

Parameter	Symbol	Conditions
Voltage V_{DD} to V_{SS}	V_{DD}	-0.3 to +6V
Voltage at any pin to V_{DD}	V_{MAX}	+0.3V
Voltage at any pin to V_{SS}	V_{MIN}	-0.3V
Current at OUTs 1-4	I_{OUTMAX}	± 35 mA
Max. junction temperature	T_j	150°C
Operating temp. range	T_A	-40 to +105°C
Storage temp. range	T_{STO}	-65 to +125°C

Table 1

Stresses beyond these listed maximum ratings may cause permanent damage to the device. Exposure to conditions beyond specified operating conditions may affect device reliability or cause malfunction.

Operating Conditions

Parameter	Symbol	Test Conditions	Min	Typ	Max	Units
Operating temperature	T_A		-40		+105	°C
Thermal impedance	$R_{th\ j-a}$	DIP package SO package		60 80		°C/W °C/W
Supply voltage	V_{DD}		4.5	5	5.5	V
Input voltage at any pin	V_{IN}		V_{SS}		V_{DD}	V

Table 2

Load Characteristics

Parameter	Symbol	Test Conditions	Min	Typ	Max	Units
Coil resistance	R_{B25}	M-S X15.xxx, $T_A=25^\circ\text{C}$	260	290	320	Ω
	R_{B-40}	M-S X15.xxx, $T_A=-40^\circ\text{C}$	190			Ω
	R_{B105}	M-S X15.xxx, $T_A=105^\circ\text{C}$	340			Ω
Phase inductance	L_{25}	M-S X15.xxx, $T_A=25^\circ\text{C}$		0.4		H

Table 3

Electrical Characteristics

$V_{DD} = 4.5 \div 5.5\text{V}$, $T_A = -40 \div 105^\circ\text{C}$, unless otherwise specified

Parameter	Symbol	Test Conditions	Min	Typ	Max	Units
Power Consumption						
Typical supply current	I_C	$V_{DD}=5\text{V}$, $\omega=200^\circ/\text{s}$, $T_A=25^\circ\text{C}$, $R_{B25}=290\Omega$		76		mA
Worst case supply current	I_{CMAX}	$V_{DD}=5.5\text{V}$, $\text{RESET}=V_{SS}$, $T_A=-40^\circ\text{C}$, $R_{B-40}=190\Omega$			200	mA
Quiescent supply current	I_{CC}	All inputs at V_{DD} or V_{SS} , no load			300	μA
Inputs						
Low level input voltage	V_{IL}	$V_{DD} = 4.5 \div 5.5\text{V}$	V_{SS}		1.35	V
High level input voltage	V_{IH}	$V_{DD} = 4.5 \div 5.5\text{V}$	3.15		V_{DD}	V
Input leakage	I_{IN}	$V_{IN} = V_{SS}$ or V_{DD}	-10		10	μA

Table 4

Timing Characteristics

$V_{DD} = 4.5 \div 5.5V$, $T_A = -40 \div 105^\circ C$, t_{rise} and $t_{fall} \leq 20ns$, input signal swing V_{SS} to V_{DD}

Parameter	Symbol	Test Conditions	Min	Typ	Max	Units
Signal pulse width	t_w	high or low	450			ns
Input frequency	$f(scx)$	Driver input limit Motor speed limit ($\omega=600^\circ/s$)			1.1 7.2	MHz kHz
Setup time to $f(scx)$	t_s	high or low	100			ns
RESET release time to $f(scx)$	t_{rr}		100			ns

Table 5

Delay Timing Waveforms

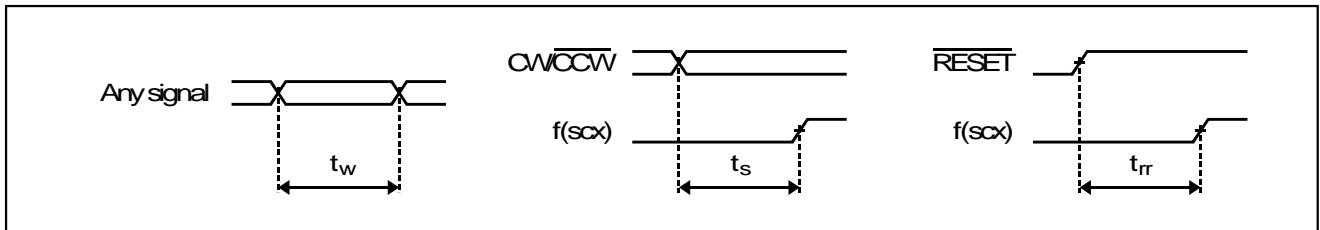

Fig.3

Pin Description

Unused inputs must always be tied to a defined logic voltage level unless otherwise specified

Pin Number DIP/SOL 28 Version	Name	I/O	Function
1 / 15	VDD	V	Positive supply voltage
12	VSS	V	Negative supply voltage
28 / 3 / 14 / 17	$f(scx)$ A / B / C / D	I	Stepping frequency; Driver A / B / C / D
27 / 2 / 13 / 16	CW/CCW A / B / C / D	I	Direction of rotation; Driver A / B / C / D
26	RESET	I	Reset for the four drivers
7 / 22 / 21 / 8	OUT 1A / 1B / 1C / 1D	O	Coil output 1; Driver A / B / C / D
6 / 23 / 20 / 9	OUT 2A / 2B / 2C / 2D	O	Coil output 2; Driver A / B / C / D
4 / 25 / 18 / 11	OUT 3A / 3B / 3C / 3D	O	Coil output 3; Driver A / B / C / D
5 / 24 / 19 / 10	OUT 4A / 4B / 4C / 4D	O	Coil output 4; Driver A / B / C / D

Table 6

Circuit Protections

To filter fast voltage transients, it is highly recommended to connect two 100nF ceramic capacitors to the power supply pins, one on either side and as close as possible to the IC.

Moreover, to protect the IC against latch-up, a 5 μ F capacitor per motor connected should be added. Thus, for 4 motors, typically a 22 μ F capacitor must be used, either electrolytic or tantalum. Note this capacitor can be placed close to the voltage regulator.

Recommended Power Up

In order to power up the circuit in a defined manner, it is recommended to keep the RESET input low while the VDD voltage is raising. After a delay of about 1ms, the RESET can be released (i.e. set high).

Depending on the microcontroller used, an external pull-down resistor might be required to properly set the RESET state at low during the start-up.

Block Diagram

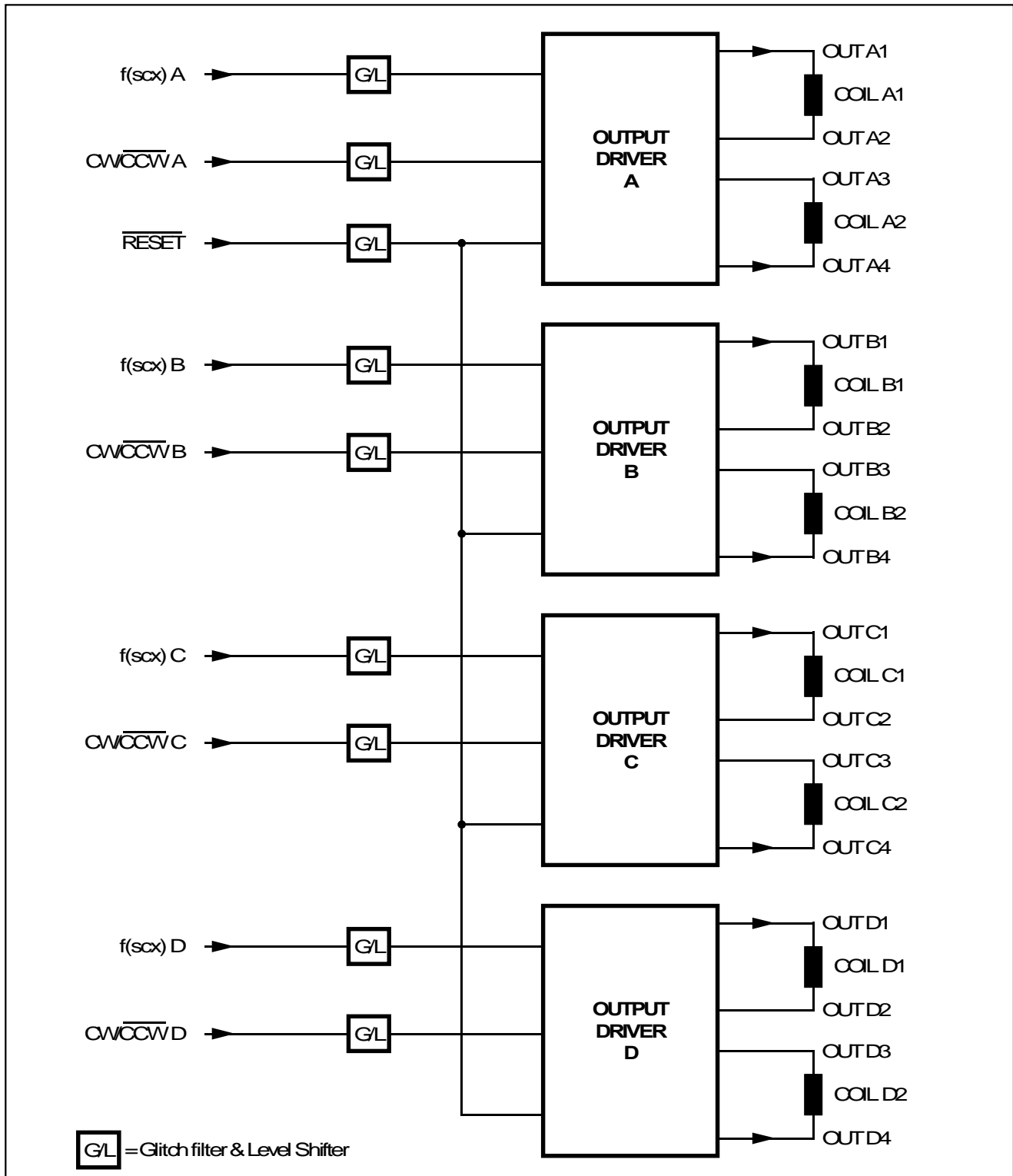

Fig. 4

Suggested Applications

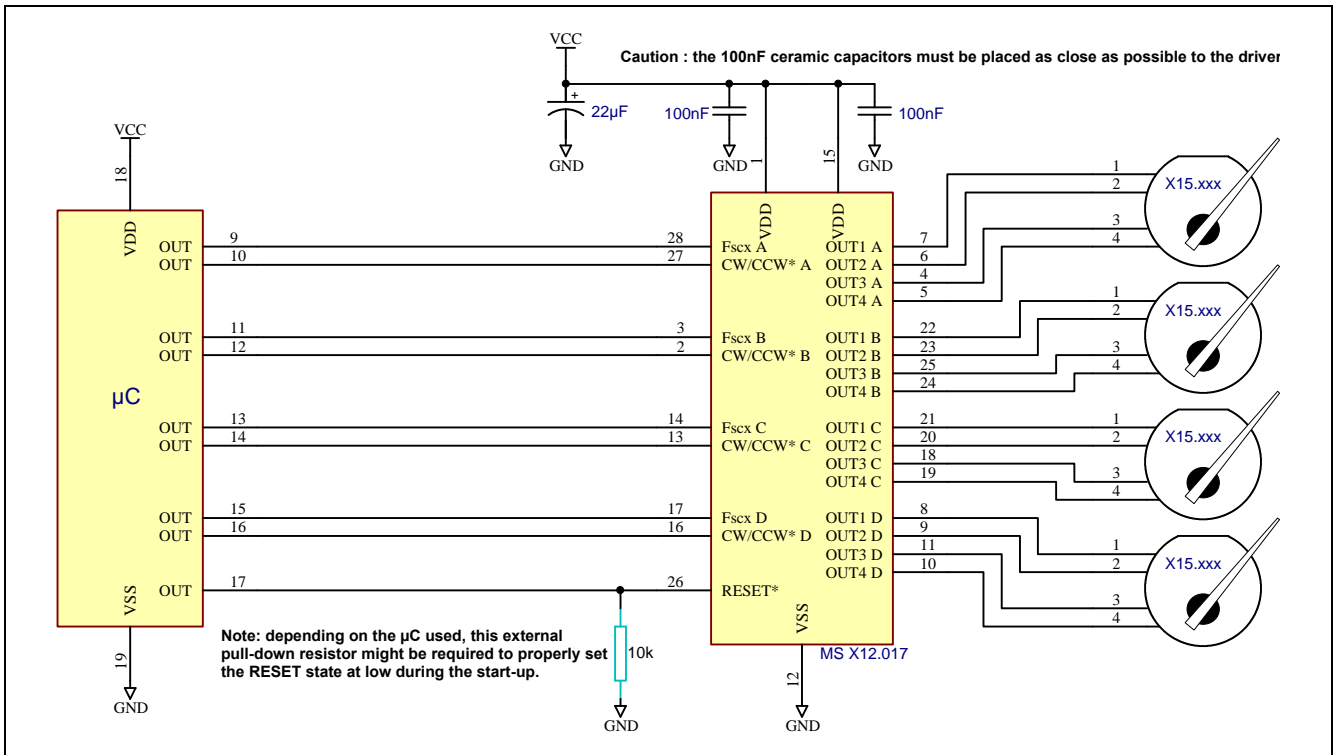

Fig. 5

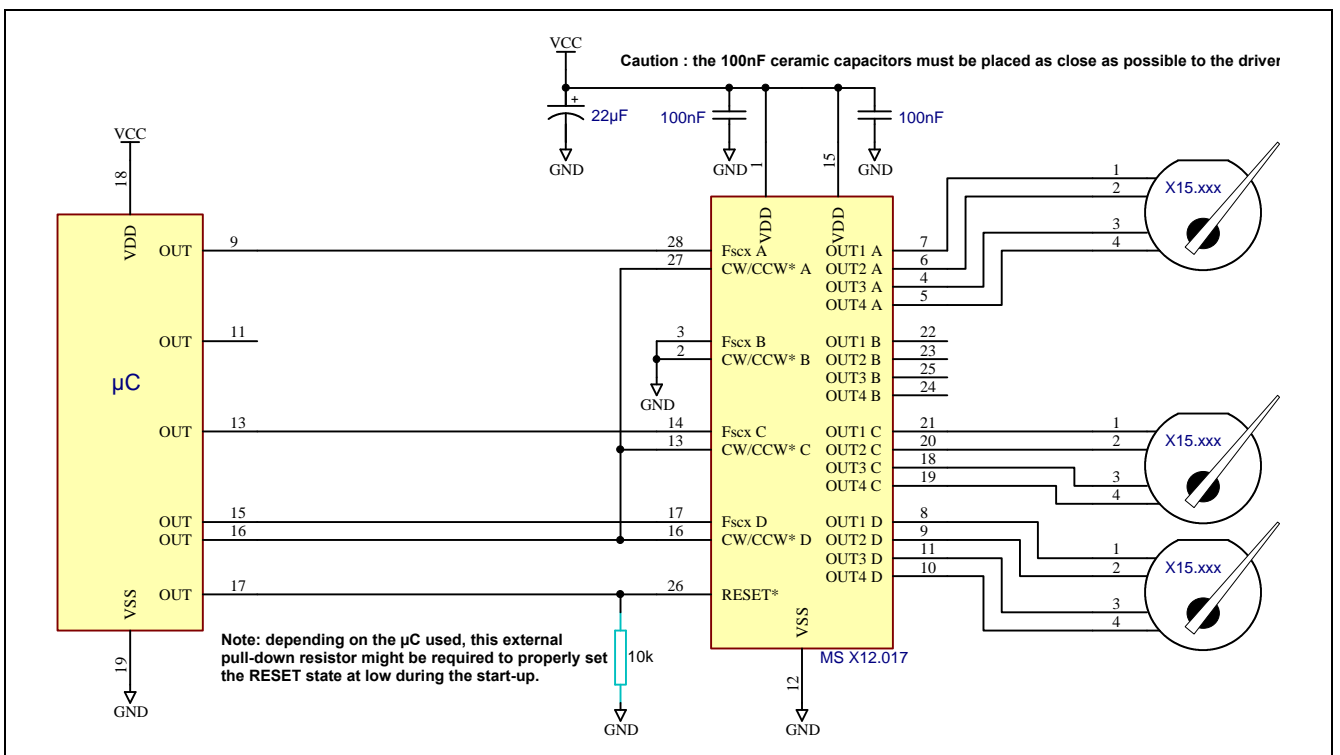

Fig. 6

Functional Description

- The rising edge of the f(scx) input signal moves the rotor by one microstep.
- The input signal "CW/CCW" (clockwise / counter-clockwise) controls the direction of rotation of the motor.
- The input signal "RESET" at low resets the output driver sequence to position 1.

Rotor Positions

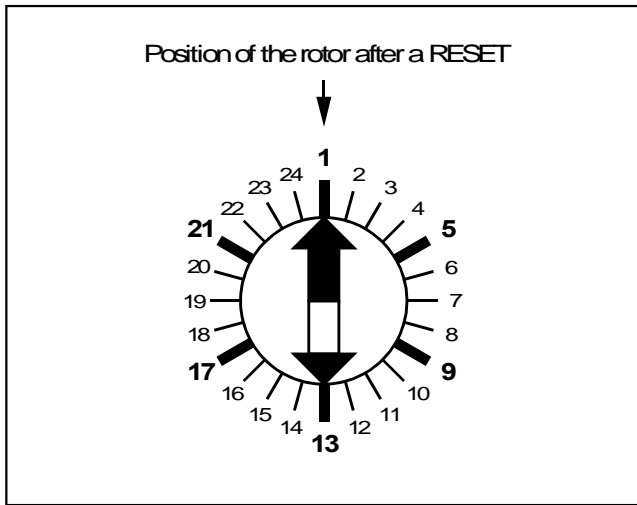

Fig. 7

M-S Stepping Modes

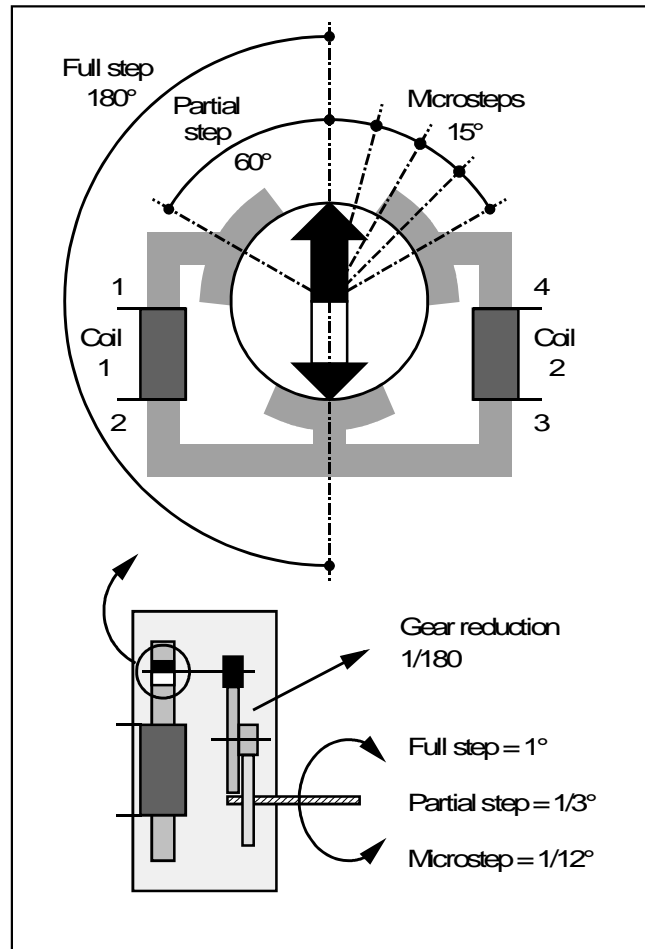

Fig. 8

Input Glitch Filter & Level Shifter

All logic inputs of the M-S Quad Driver are armed with a glitch filter to avoid erroneous information due to spikes and glitches on the input signal lines. All negative or positive pulses of less than 20 ns width are ignored.

A minimum signal pulse width (positive or negative) of 450 ns guarantees correct function over the full temperature range.

All logic inputs also feature a level shifter, which allows for operation of the circuit at a higher supply voltage (V_{DD}) than the circuits driving the inputs. This is in order to drive the M-S motors at a higher torque level.

The Output Driver

The output driver converts the pulse train of f(scx) into a current level sequence sent to the two motor coils of the M-S. This sequence of 24 current levels per rotor revolution is used to produce the microstepping movement of the rotor.

A microstep is an angular rotation of 1/12 deg. of the M-S shaft or 15 deg. on the rotor shaft.

A partial step is an angular rotation of 1/3 deg. of the M-S shaft or 60 deg. on the rotor shaft.

A full step is an angular rotation of 1 deg. of the M-S shaft or 180 deg. on the rotor shaft.

The microstepping allows for smooth and appealing movement of a pointer if the M-S is used as pointer drive. It is not intended as a precise positioning. The precision of the angular position is given by the resolution of the partial step.

Dimensions of DIP Package

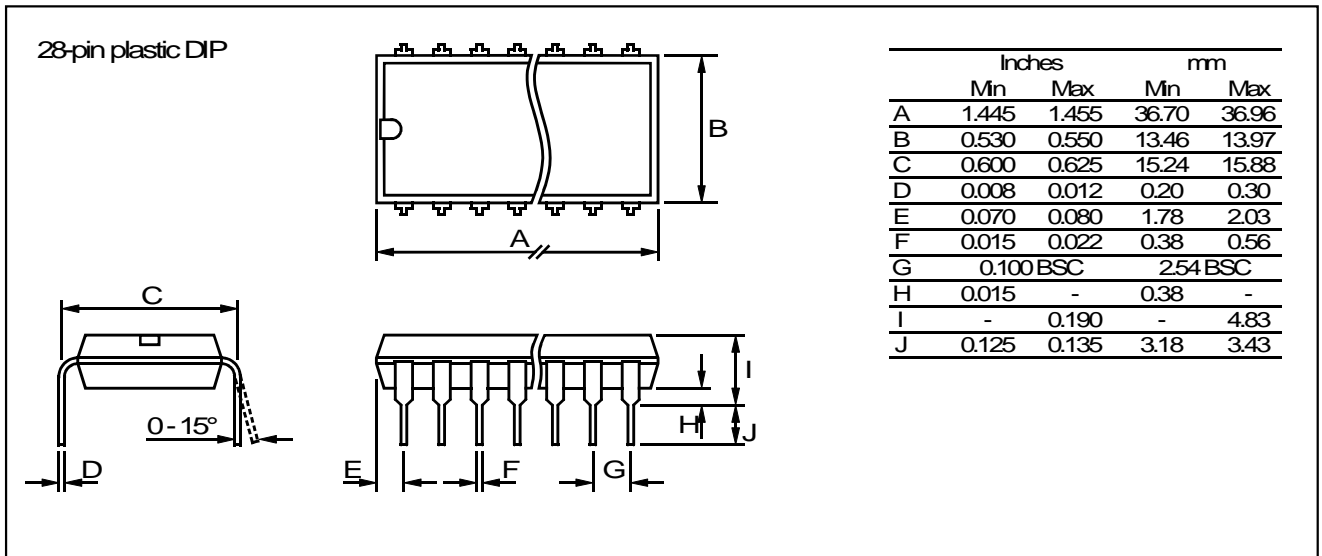

Fig. 9

Dimensions of SOL Package

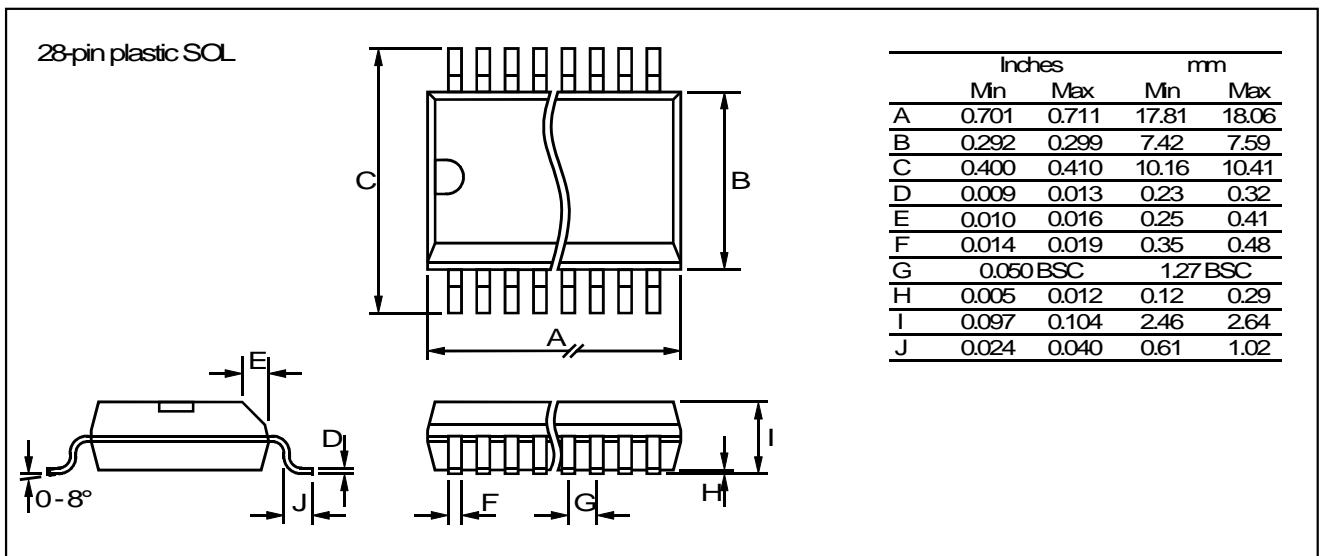

Fig. 10

Ordering Information

The M-S Quad Driver X12.017 is available in the following packages:

- DIP 28-pin plastic package
- SOL 28-pin wide plastic package

M-S Quad Driver X12.017 - DIP28
M-S Quad Driver X12.017 - SOL28

Chip form on request.

When ordering, please specify the complete part number and package.

Table of Contents

M-S Quad Driver X12.017	1	Pin Description	3
Features	1	Circuit Protections	3
Description	1	Recommended Power Up	3
Applications	1	Block Diagram	4
Typical Operating Configuration	1	Suggested Applications	5
Pin Assignment	1	Functional Description	6
Absolute Maximum Ratings	2	Rotor Positions	6
Handling Procedures	2	Input Glitch Filter & Level Shifter	6
Operating Conditions	2	M-S Stepping Modes	6
Load Characteristics	2	The Output Driver	6
Electrical Characteristics	2	Dimensions of DIP Package	7
Timing Characteristics	3	Dimensions of SOL Package	7
Delay Timing Waveforms	3	Ordering Information	7

The information and specifications given here are correct and valid to the best of our knowledge. However **switec**[™] assumes no liability for damages which may arise through the incorrect use of this information or for eventual damages to existing patents or to the rights of third parties. The general purchase conditions for electrical and mechanical products of **switec**[™] apply to all commercial transactions.

switec[™] reserves the right to make changes in the products contained in this document in order to improve design or performance and to supply the best possible products.

switec[™] is a trade mark of the Swatch Group Management Services AG.