

This document is the property of Amphenol Corporation and is delivered on the express condition that it is not to be disclosed, reproduced or used, in whole or in part, for manufacture or sale by anyone other than Amphenol Corporation without its prior consent, & that no right is granted to disclose or to use any information in this document.

Customer drawing

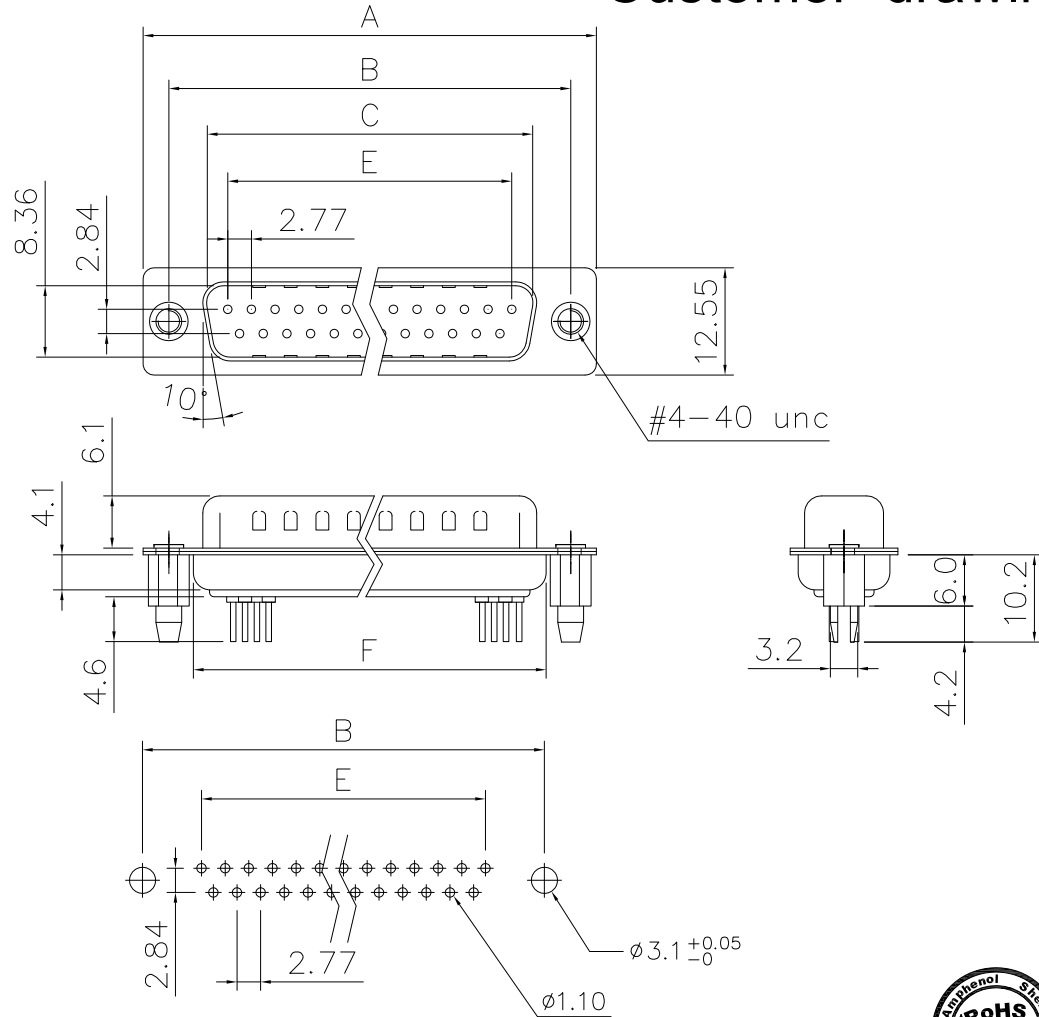

RECOMMENDED P.C.B LAYOUT
(TOLERANCE +/-0.05)



Dimensions

Positions	A	B	C	E	F
9	30.81	24.99	16.92	11.08	19.20
15	39.20	33.30	25.25	19.39	27.70
25	53.04	47.04	38.96	33.24	41.10
37	69.40	63.50	55.42	49.86	57.30

REVISIONS				
SYM	ECN	DESCRIPTION	DATE	APPROVED
1	HK--	First Release Drawing	08/22/08	IP
2	HK--	Update the Drawing	09/06/13	IP

D-SUB TECHNICAL DATA

SHELL : Steel, 100u" min tin over 50u" min nickel over 50u" min copper
 BODY : Glass-Filled Thermoplastic PBT, UL94V-0
 CONTACTS : Copper alloy
 Gold flash over 50u" nickel on mating area;
 100u" tin over 50u" nickel on solder area
 BOARDLOCK : Copper alloy, Tin plated
 ELECTRICAL : Voltage rating 250 V Rms to 60 Hz
 Current rating 3A
 Withstanding Voltage >1000 V Rms to 60 Hz for one minute
 Insulation resistance >1000 M Ohms
 Contact resistance 20 mOhms max.
 MARKING : Amphenol...(Series No.)
 Commercial reference
 Manufacturing date

PRODUCT CODE

L 717 SD X H XX P OL2 RM5

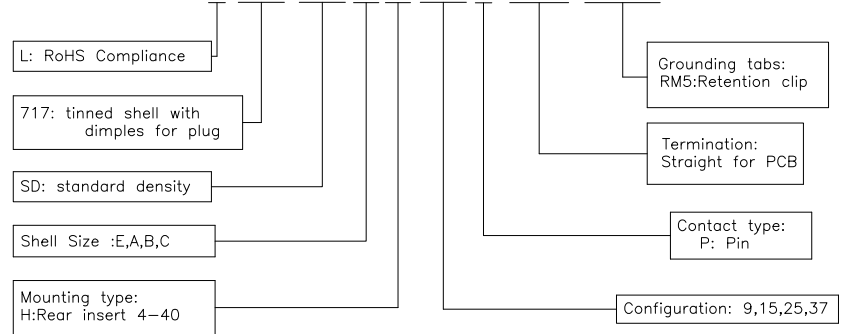

UNLESS OTHERWISE SPECIFIED TOLERANCES		APPROVAL		DATE
U.S.	METRIC	DRAWN	Checked	
.X +/-	0.50	Felix Liu		09/06/13
.XX +/-	0.30	Tony Tang		09/06/13
.XXX +/-	0.20	CHECKED		
FRACTIONS +/-				
ANGLES +/-	5°			
FOR MATERIALS AND FINISHES SEE NOTES		DRAWING FILE :		
REMOVE SHARP EDGES		ANGLE OF PROJECTION		
DIMENSIONS				
U.S.	INCHES			
METRIC	MM			

Amphenol		
Amphenol East Asia Limited		
TITLE Straight PCB termination,SD Series		
SIZE	DRAWING NO.	REV.
A4	C L717SDXHXXPOL2RM5	2
SCALE	NONE	SHEET 1 OF 1