

QJ—3640-1-2011

SPECIFICATION

OF PRODUCTS

CUSTOMER : _____

PRODUCT NAME: DIELECTRIC ANTENNA ELEMENT

PART NUMBER : DAE1590R2540AKDB1-T

Approved by	Checked by	Drawn by

ZHEJIANG JIAKANG ELECTRONICS CO., LTD.

Add: No.1188, Jiahang Road, Jiaxing, Zhejiang, China (314001)

Tel : +86-573-82600912 82600913 82600953 82600955

Fax : +86-573-82600916

E-mail : sales@jkelec.com

Approval Sheet	
Customer	
Supplier P/N	DAE1590R2540AKDB1-T
Customer P/N	

Customer's Approval Certificate	
Checked & Approval by	
Date	

Please return this copy as a certification of your approval.

Add: No.1188, Jiahang Road, Jiaying, Zhejiang, China (314001)
Tel : +86-573-82600912 82600953 Fax : +86-573-82600916
E-mail : sales@jkelec.com

1 SCOPE

This specification shall cover the characteristics of the dielectric antenna element with the type DAE1590R2540AKDB1-T.

2 PART NO.

PART NUMBER	CUSTOMER PART NO	SPECIFICATION NO
DAE1590R2540AKDB1-T		

3 OUTLINE DRAWING AND DIMENSIONS

3.1 Appearance: No visible damage and dirt.

3.2 The products conform to the RoHS directive and national environment protection law.

3.3 Dimensions

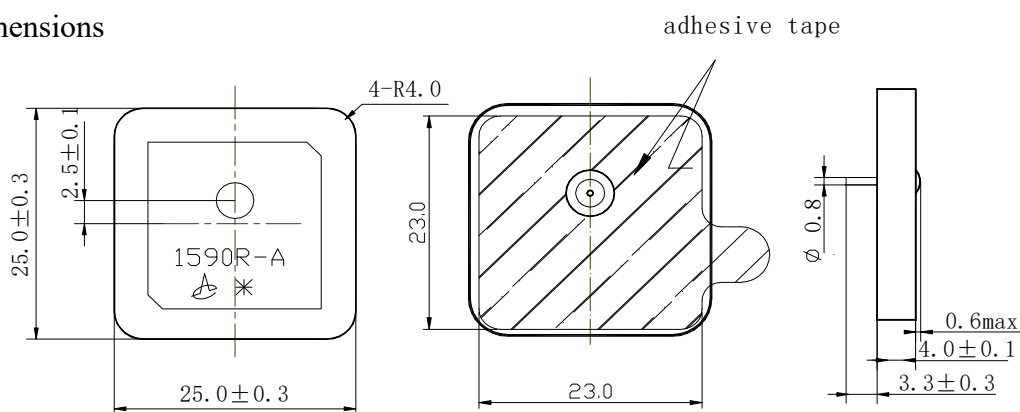

*: EIAJ Monthly Code

4 ELECTRICAL SPECIFICATIONS

4.1 Performance Characteristics

Items	Content
Center frequency MHz (without tape on 70×70mm ground plane)	1575~1608 (GPS : 1575, GLONASS : 1592~1608)
Return Loss at CF min dB	7
Peak Gain at 1575MHz dBiC	4.45
Peak Gain at 1609MHz dBiC	4.20
Impedance Ω	50
Polarization Model	RHCP
permittivity	21
Frequency Temperature Coefficient	20ppm/deg.°C max

Add: No.1188, Jiahang Road, Jiaying, Zhejiang, China (314001)

Tel : +86-573-82600912 82600953 Fax : +86-573-82600916

E-mail : sales@jkelec.com

4.2 Impedance Characteristic

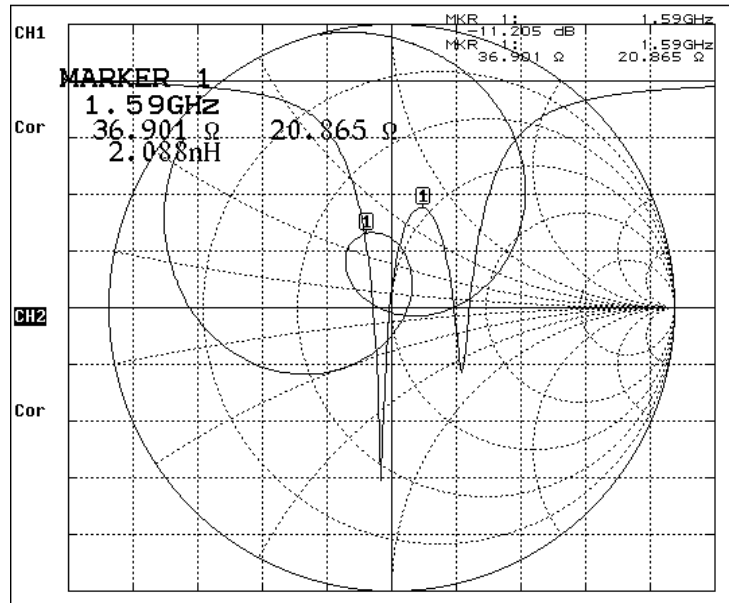

5 TEST

5.1 Test Conditions

Parts shall be measured under a condition (Temp.: $20^{\circ}\text{C}\pm 15^{\circ}\text{C}$, Humidity : $65\%\pm 20\%$ R.H.).

5.2 Test Jig

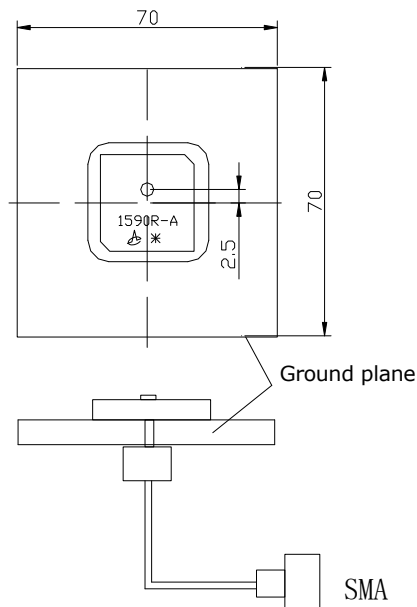

Add: No.1188, Jiahang Road, Jiaxing, Zhejiang, China (314001)

Tel : +86-573-82600912 82600953 Fax : +86-573-82600916

E-mail : sales@jkelec.com

6 ENVIRONMENTAL TEST

No.	Item	Test Condition	Remark
6.1	Humidity Test	The device is subjected to 90%~95% relative humidity $60^{\circ}\text{C} \pm 3^{\circ}\text{C}$ for 96h, then dry out at $25^{\circ}\text{C} \pm 5^{\circ}\text{C}$ and less than 65% relative humidity for 2h~4h. After dry out the device shall satisfy the specification in table 1.	It shall fulfill the specifications in Table 1.
6.2	High Temperature Exposure	The device shall satisfy the specification in table 1 after leaving at 105°C for 96h, provided it would be measured after 2h~4h leaving in $25^{\circ}\text{C} \pm 5^{\circ}\text{C}$ and less than 65% relative humidity.	It shall fulfill the specifications in Table 1.
6.3	Low Temperature	The device shall satisfy the specification in table 1 after leaving at -40°C for 96h, provided it would be measured after 2h~4h leaving in $25^{\circ}\text{C} \pm 5^{\circ}\text{C}$ and less than 65% relative humidity.	It shall fulfill the specifications in Table 1.
6.4	Temperature Cycle	Subject the device to -40°C for 30 min. followed by a high temperature of 105°C for 30 min cycling shall be repeated 5 times. At the room temperature for 1h prior to the measurement.	It shall fulfill the specifications in Table 1.
6.5	Vibration	Subject the device to vibration for 2h each in x, y and z axis with the amplitude of 1.5mm, the frequency shall be varied uniformly between the limits of 10Hz~55Hz.	It shall fulfill the specifications in Table 1.
6.6	Soldering Test	Lead terminals are heated up to $350^{\circ}\text{C} \pm 10^{\circ}\text{C}$ for $5\text{s} \pm 0.5\text{s}$ with brand iron and then element shall be measured after being placed in natural conditions for 1 h. No visible damage and it shall fulfill the specifications in Table 1	It shall fulfill the specifications in Table 1.
6.7	Solder ability	Lead terminals are immersed in soldering bath of $260^{\circ}\text{C} \sim 290^{\circ}\text{C}$ for $3\text{s} \pm 0.5\text{s}$. More than 95% of the terminal surface of the device shall be covered with fresh solder.	The terminals shall be at least 95% covered by solder.
6.8	Terminal Pressure Strength	Force of 2kg is applied to each lead in axial direction for $10\text{s} \pm 1\text{s}$ (see drawing). No visible damage and it shall fulfill the specifications in Fig 1	Mechanical damage such as breaks shall not occur.

Add: No.1188, Jiahang Road, Jiaying, Zhejiang, China (314001)

Tel : +86-573-82600912 82600953 Fax : +86-573-82600916

E-mail : sales@jkelec.com

FIG 1

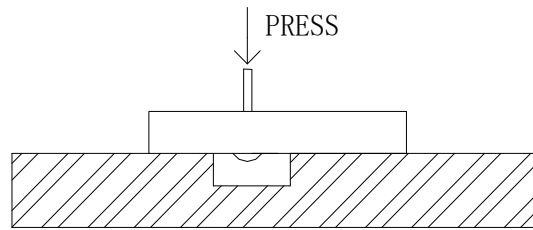

TABLE 1

Item	Specification After Test (MHz)
Center Frequency change	± 2.0
-10dB Bandwidth Change	± 2.0

Add: No.1188, Jiahang Road, Jiaying, Zhejiang, China (314001)

Tel : +86-573-82600912 82600953 Fax : +86-573-82600916

E-mail : sales@jkelec.com