

Features

- Low-Voltage and Standard-Voltage Operation:
 - $V_{CC} = 1.7V$ to $5.5V$
 - $V_{CC} = 2.5V$ to $5.5V$
- Internally Organized as 262,144 x 8 (2-Mbit)
- Industrial Temperature Range: $-40^{\circ}C$ to $+85^{\circ}C$
- I²C-Compatible (Two-Wire) Serial Interface:
 - 100 kHz Standard Mode, 1.7V to 5.5V
 - 400 kHz Fast Mode, 1.7V to 5.5V
 - 1 MHz Fast Mode Plus (FM+), 2.5V to 5.5V
- Schmitt Triggers, Filtered Inputs for Noise Suppression
- Bidirectional Data Transfer Protocol
- Write-Protect Pin for Full Array Hardware Data Protection
- Ultra Low Active Current (3 mA maximum) and Standby Current (3 μ A maximum)
- 256-Byte Page Write Mode:
 - Byte write and partial page writes allowed
- Random and Sequential Read Modes
- Self-Timed Write Cycle:
 - All write operations complete within 10 ms maximum
- Built-in Error Detection and Correction
- High Reliability:
 - Endurance: 1,000,000 write cycles
 - Data retention: 100 years
- Green Package Options (RoHS compliant)
- Die Sale Options: Wafer Form and Bumped Wafers

Packages

- 8-Lead SOIC and 8-Ball WLCSP

Table of Contents

Features.....	1
Packages.....	1
1. Package Types (not to scale).....	4
2. Pin Descriptions.....	5
2.1. Device Address Input (A2).....	5
2.2. Ground.....	5
2.3. Serial Data (SDA).....	5
2.4. Serial Clock (SCL).....	5
2.5. Write-Protect (WP).....	5
2.6. Device Power Supply.....	6
3. Description.....	7
3.1. System Configuration Using Two-Wire Serial EEPROMs	7
3.2. Block Diagram.....	8
4. Electrical Characteristics.....	9
4.1. Absolute Maximum Ratings.....	9
4.2. DC and AC Operating Range.....	9
4.3. DC Characteristics.....	9
4.4. AC Characteristics.....	10
4.5. Electrical Specifications.....	11
5. Device Operation and Communication.....	13
5.1. Clock and Data Transition Requirements.....	13
5.2. Start and Stop Conditions.....	13
5.3. Acknowledge and No-Acknowledge.....	14
5.4. Standby Mode.....	14
5.5. Software Reset.....	14
6. Memory Organization.....	16
6.1. Device Addressing.....	16
7. Write Operations.....	17
7.1. Byte Write.....	17
7.2. Page Write.....	17
7.3. Internal Writing Methodology.....	18
7.4. Acknowledge Polling.....	18
7.5. Write Cycle Timing.....	19
7.6. Write Protection.....	19
8. Read Operations.....	21
8.1. Current Address Read.....	21
8.2. Random Read.....	21
8.3. Sequential Read.....	22
9. Device Default Condition from Microchip.....	24

10. Packaging Information.....	25
10.1. Package Marking Information.....	25
11. Revision History.....	32
Microchip Information.....	33
The Microchip Website.....	33
Product Change Notification Service.....	33
Customer Support.....	33
Product Identification System.....	34
Microchip Devices Code Protection Feature.....	34
Legal Notice.....	35
Trademarks.....	35
Quality Management System.....	36
Worldwide Sales and Service.....	37

1. Package Types (not to scale)

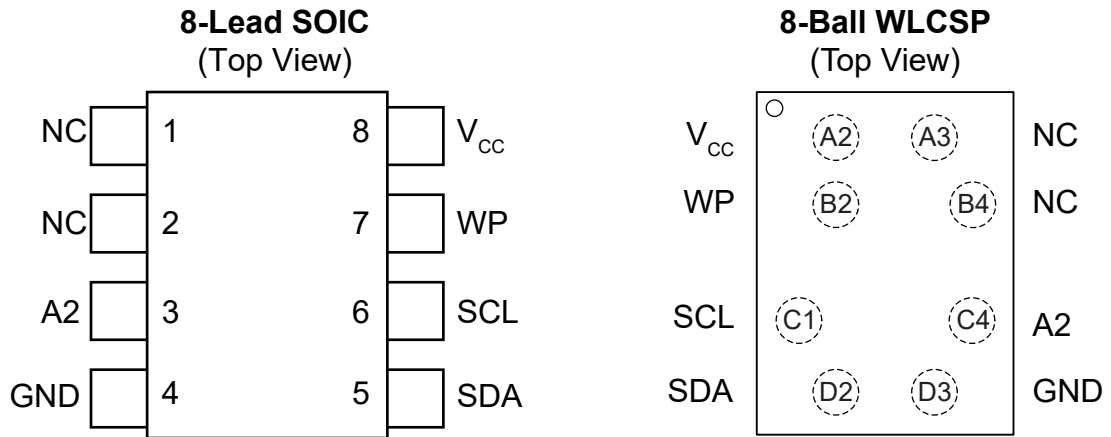

2. Pin Descriptions

The descriptions of the pins are listed in [Table 2-1](#).

Table 2-1. Pin Function Table

Name	8-Lead SOIC	8-Ball WLCSP	Function
NC	1	A3	No Connect
NC	2	B4	No Connect
A2 ⁽¹⁾	3	C4	Device Address Input
GND	4	D3	Ground
SDA	5	D2	Serial Data
SCL	6	C1	Serial Clock
WP ⁽¹⁾	7	B2	Write-Protect
V _{CC}	8	A2	Device Power Supply

Note:

1. If the A2 or WP pins are not driven, they are internally pulled down to GND. In order to operate in a wide variety of application environments, the pull-down mechanism is intentionally designed to be somewhat strong. Once these pins are biased above the CMOS input buffer's trip point ($\sim 0.5 \times V_{CC}$), the pull-down mechanism disengages. Microchip recommends connecting these pins to a known state whenever possible.

2.1 Device Address Input (A2)

The A2 pin is a device address input that is hardwired (directly to GND or to V_{CC}) for compatibility with other two-wire Serial EEPROM devices. When the pin is hardwired, as many as two devices may be addressed on a single bus system. A device is selected when a corresponding hardware and software match is true. If the pin is left floating, the A2 pin will be internally pulled down to GND. However, due to capacitive coupling that may appear in customer applications, Microchip recommends always connecting the address pin to a known state. When using a pull-up resistor, Microchip recommends using 10 k Ω or less.

2.2 Ground

The ground reference for the power supply. GND should be connected to the system ground.

2.3 Serial Data (SDA)

The SDA pin is an open-drain bidirectional input/output pin used to serially transfer data to and from the device. The SDA pin must be pulled high using an external pull-up resistor (not to exceed 10 k Ω in value) and may be wire-ORed with any number of other open-drain or open-collector pins from other devices on the same bus.

2.4 Serial Clock (SCL)

The SCL pin is used to provide a clock to the device and to control the flow of data to and from the device. Command and input data present on the SDA pin are always latched in on the rising edge of SCL, while output data on the SDA pin are clocked out on the falling edge of SCL. The SCL pin must either be forced high when the serial bus is idle or pulled high using an external pull-up resistor.

2.5 Write-Protect (WP)

The write-protect input, when connected to GND, allows normal write operations. When the WP pin is connected directly to V_{CC}, all write operations to the protected memory are inhibited.

If the pin is left floating, the WP pin will be internally pulled down to GND. However, due to capacitive coupling that may appear in customer applications, connecting the WP pin to a known state is recommended. When using a pull-up resistor, using 10 k Ω or less is recommended.

Table 2-2. Write-Protect

WP Pin Status	Part of the Array Protected
At V_{CC}	Full Array
At GND	Normal Write Operations

2.6 Device Power Supply

The V_{CC} pin is used to supply the source voltage to the device. Operations at invalid V_{CC} voltages may produce spurious results and should not be attempted.

3. Description

The AT24CM02 provides 2,097,152 bits of Serial Electrically Erasable and Programmable Read-Only Memory (EEPROM) organized as 262,144 words of 8 bits each. The device's cascading feature allows up to four devices to share a common two-wire bus. This device is optimized for use in many industrial and commercial applications where low-power and low-voltage operations are essential. The device is available in space-saving 8-lead SOIC and 8-ball WLCSP packages. All packages operate from 1.7V to 5.5V.

3.1 System Configuration Using Two-Wire Serial EEPROMs

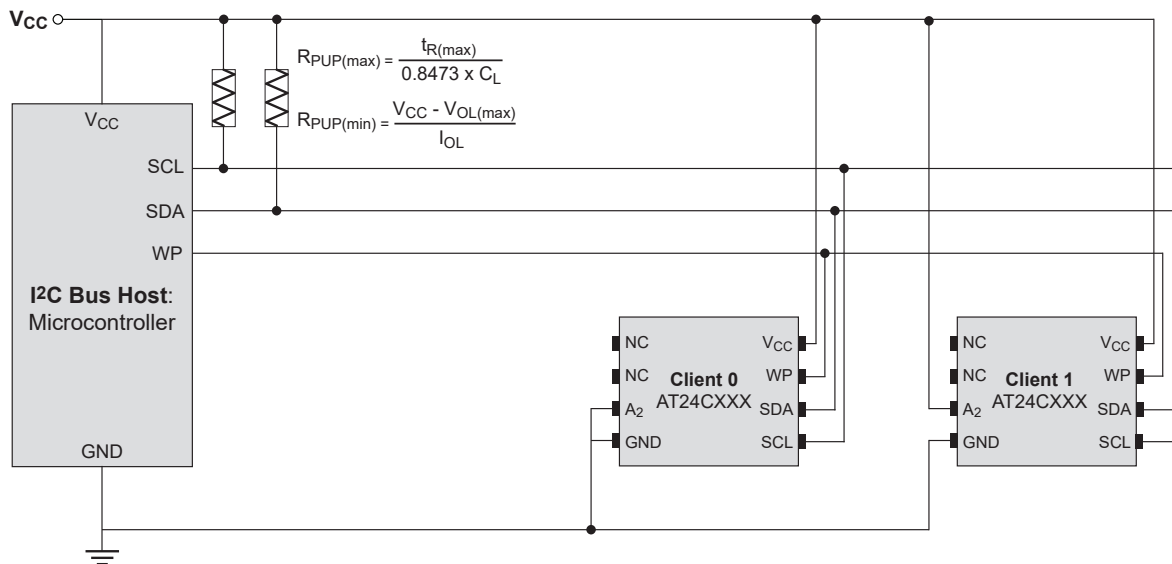

3.2 Block Diagram

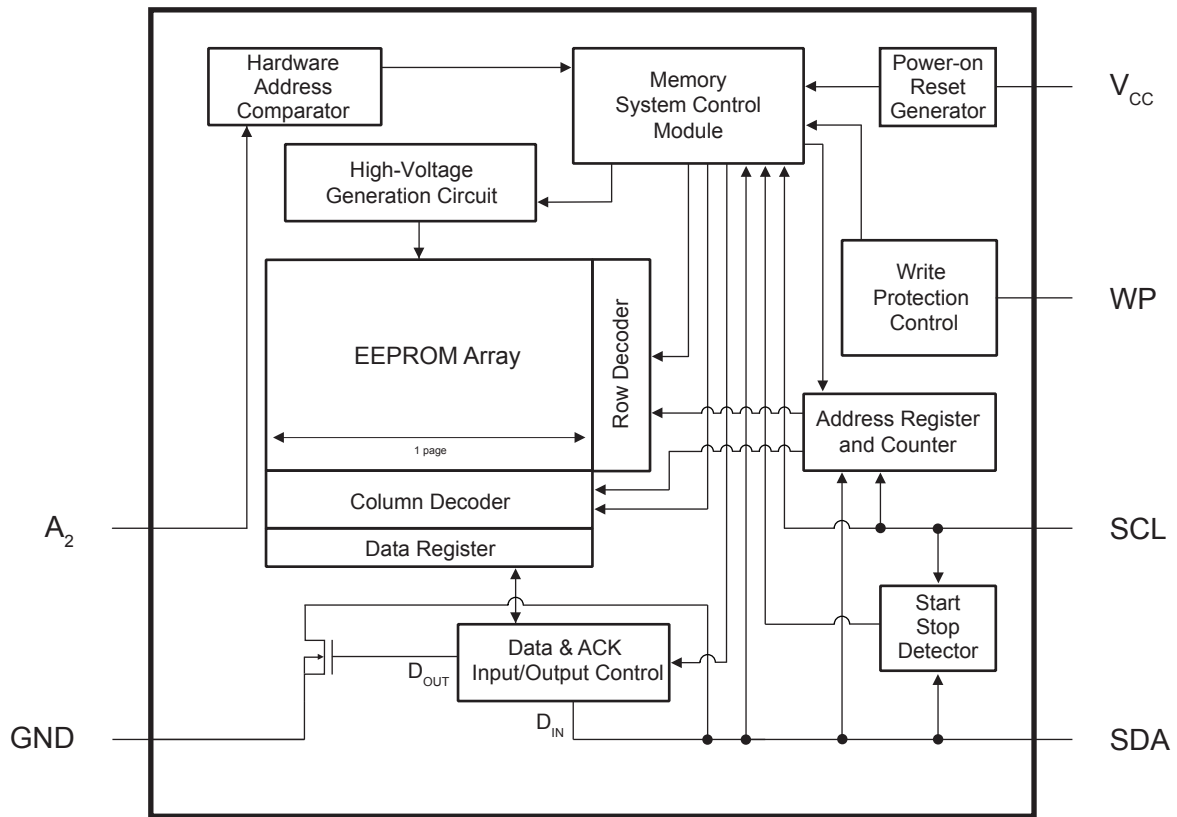

4. Electrical Characteristics

4.1 Absolute Maximum Ratings

Temperature under bias	-55°C to +125°C
Storage temperature	-65°C to +150°C
V_{CC}	6.25V
Voltage on any pin with respect to ground	-1.0V to +7.0V
DC output current	5.0 mA
ESD protection	>3 kV

Note: Stresses above those listed under “Absolute Maximum Ratings” may cause permanent damage to the device. This is a stress rating only, and functional operation of the device at these or any other conditions above those indicated in the operation listings of this specification is not implied. Exposure to absolute maximum rating conditions for extended periods may affect device reliability.

4.2 DC and AC Operating Range

Table 4-1. DC and AC Operating Range

AT24CM02		
Operating Temperature (Case)	Industrial Temperature Range	-40°C to +85°C
V_{CC} Power Supply	Low-Voltage Grade	1.7V to 5.5V
	Standard-Voltage Grade	2.5V to 5.5V

4.3 DC Characteristics

Table 4-2. DC Characteristics

Parameter	Symbol	Minimum	Maximum	Units	Test Conditions
Supply Voltage, 1.7V Option	V_{CC1}	1.7	5.5	V	
Supply Voltage, 2.5V Option	V_{CC2}	2.5	5.5	V	
Supply Current, Read	I_{CC}	—	0.5	mA	$V_{CC} = 1.8V^{(1)}$, Read at 400 kHz
		—	1.0	mA	$V_{CC} = 5.0V$, Read at 1 MHz
Supply Current, Write ⁽²⁾	I_{CC}	—	1.0	mA	$V_{CC} = 1.8V^{(1)}$, averaged during t_{WR}
		—	3.0	mA	$V_{CC} = 5.0V$, averaged during t_{WR}
Standby Current	I_{SB}	—	1.0	μA	$V_{CC} = 1.8V^{(1)}$, $V_{IN} = V_{CC}$ or V_{SS}
		—	2.0	μA	$V_{CC} = 2.5V$, $V_{IN} = V_{CC}$ or V_{SS}
		—	3.0	μA	$V_{CC} = 5.5V$, $V_{IN} = V_{CC}$ or V_{SS}
Input Leakage Current	I_{LI}	—	3.0	μA	$V_{IN} = V_{CC}$ or V_{SS}
Output Leakage Current	I_{LO}	—	3.0	μA	$V_{OUT} = V_{CC}$ or V_{SS}
Input Low Level	V_{IL}	-0.6	$V_{CC} \times 0.3$	V	Note 1
Input High Level	V_{IH}	$V_{CC} \times 0.7$	$V_{CC} + 0.5$	V	Note 1
Output Low Level	V_{OL1}	—	0.2	V	$V_{CC} = 1.7V$, $I_{OL} = 0.15$ mA
Output Low Level	V_{OL2}	—	0.4	V	$V_{CC} = 3.0V$, $I_{OL} = 2.1$ mA

Note:

1. This parameter is characterized but is not 100% tested in production.
2. Averaged during t_{WR} .

4.4 AC Characteristics

Table 4-3. AC Characteristics⁽¹⁾

Parameter	Symbol	Standard Mode		Fast Mode		Fast Mode Plus		Units
		$V_{CC} = 1.7V \text{ to } 5.5V$		$V_{CC} = 1.7V \text{ to } 5.5V$		$V_{CC} = 2.5V \text{ to } 5.5V$		
		Min.	Max.	Min.	Max.	Min.	Max.	
Clock Frequency, SCL	f_{SCL}	—	100	—	400	—	1000	kHz
Clock Pulse Width Low	t_{LOW}	4,700	—	1,300	—	500	—	ns
Clock Pulse Width High	t_{HIGH}	4,000	—	600	—	400	—	ns
Input Filter Spike Suppression (SCL,SDA) ⁽²⁾	t_i	—	100	—	100	—	50	ns
Clock Low to Data Out Valid	t_{AA}	—	4,500	—	900	—	450	ns
Bus Free Time between Stop and Start ⁽²⁾	t_{BUF}	4,700	—	1,300	—	500	—	ns
Start Hold Time	$t_{HD,STA}$	4,000	—	600	—	250	—	ns
Start Set-up Time	$t_{SU,STA}$	4,700	—	600	—	250	—	ns
Data In Hold Time	$t_{HD,DAT}$	0	—	0	—	0	—	ns
Data In Set-up Time	$t_{SU,DAT}$	200	—	100	—	100	—	ns
Inputs Rise Time ⁽¹⁾	t_R	—	1,000	—	300	—	100	ns
Inputs Fall Time ⁽¹⁾	t_F	—	300	—	300	—	100	ns
Stop Condition Set-up Time	$t_{SU,STO}$	4,700	—	600	—	250	—	ns
Write-Protect Setup Time	$t_{SU,WP}$	4,000	—	600	—	250	—	ns
Write-Protect Hold Time	$t_{HD,WP}$	4,000	—	600	—	250	—	ns
Data Out Hold Time	t_{DH}	100	—	50	—	50	—	ns
Write Cycle Time	t_{WR}	—	10	—	10	—	10	ms

Notes:

- AC measurement conditions:
 - C_L : 100 pF
 - R_{PUP} (SDA bus line pull-up resistor to V_{CC}): 1.3 k Ω (1000 kHz), 4 k Ω (400 kHz), 10 k Ω (100 kHz)
 - Input pulse voltages: $0.3 \times V_{CC}$ to $0.7 \times V_{CC}$
 - Input rise and fall times: ≤ 50 ns
 - Input and output timing reference voltages: $0.5 \times V_{CC}$
- These parameters are determined through product characterization and are not 100% tested in production.

Figure 4-1. Bus Timing

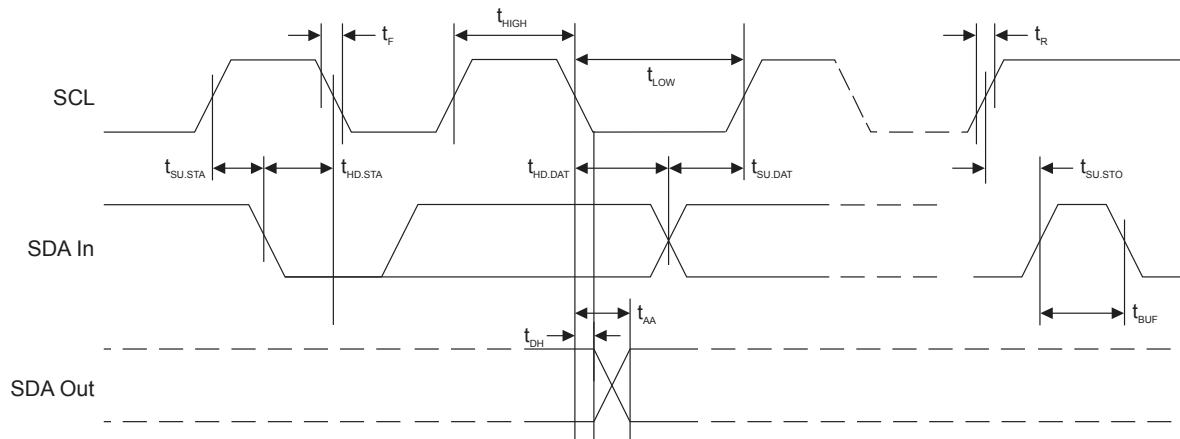

4.5 Electrical Specifications

4.5.1 Power-Up Requirements and Reset Behavior

During a power-up sequence, the V_{CC} supplied to the AT24CM02 should monotonically rise from GND to the minimum V_{CC} level, as specified in Table 4-1, with a slew rate no faster than 0.1 V/ μ s.

4.5.1.1 Device Reset

To prevent inadvertent write operations or any other spurious events from occurring during a power-up sequence, the AT24CM02 includes a Power-on Reset (POR) circuit. Upon power-up, the device will not respond to any commands until the V_{CC} level crosses the internal voltage threshold (V_{POR}) that brings the device out of Reset and into Standby mode.

The system designer must ensure the instructions are not sent to the device until the V_{CC} supply has reached a stable value greater than or equal to the minimum V_{CC} level. Additionally, once the V_{CC} is greater than or equal to the minimum V_{CC} level, the bus host must wait at least t_{PUP} before sending the first command to the device. See Table 4-4 for the values associated with these power-up parameters.

Table 4-4. Power-up Conditions⁽¹⁾

Symbol	Parameter	Min.	Max.	Units
t_{PUP}	Time required after V_{CC} is stable before the device can accept commands	100	—	μ s
V_{POR}	Power-on Reset Threshold Voltage	—	1.5	V
t_{POFF}	Minimum time at $V_{CC} = 0V$ between power cycles	1	—	ms

Note:

- These parameters are characterized but are not 100% tested in production.

If an event occurs in the system where the V_{CC} level supplied to the AT24CM02 drops below the maximum V_{POR} level specified, it is recommended that a full power cycle sequence be performed. First, drive the V_{CC} pin to GND, waiting at least the minimum t_{POFF} time, and then perform a new power-up sequence in compliance with the requirements defined in this section.

4.5.2 Pin Capacitance

Table 4-5. Pin Capacitance⁽¹⁾

Symbol	Test Condition	Max.	Units	Conditions
$C_{I/O}$	Input/Output Capacitance (SDA)	8	pF	$V_{I/O} = 0V$

.....continued

Symbol	Test Condition	Max.	Units	Conditions
C_{IN}	Input Capacitance (A2 and SCL)	6	pF	$V_{IN} = 0V$

Note:

1. This parameter is characterized but is not 100% tested in production.

4.5.3 EEPROM Cell Performance Characteristics

Table 4-6. EEPROM Cell Performance Characteristics

Operation	Test Condition	Min.	Max.	Units
Write Endurance ⁽¹⁾	$T_A = 25^{\circ}C$, $V_{CC}(\text{min.}) < V_{CC} < V_{CC}(\text{max.})$, Byte ⁽²⁾ or Page Write mode	1,000,000	—	Write Cycles
Data Retention ⁽¹⁾	$T_A = 55^{\circ}C$	100	—	Years

Notes:

1. Performance is determined through characterization and the qualification process.
2. Due to the memory array architecture, the Write Cycle Endurance is specified for writes in groups of four data bytes. The beginning of any 4-byte boundaries can be determined by multiplying any integer (N) by four (i.e., $4*N$). The end address can be found by adding three to the beginning value (i.e., $4*N+3$). See [Internal Writing Methodology](#) for more details on this implementation.

5. Device Operation and Communication

The AT24CM02 operates as a client device and utilizes a simple I²C-compatible Two-Wire digital serial interface to communicate with a host controller, commonly referred to as the bus host. The host initiates and controls all read and write operations to the client devices on the serial bus, and both the host and the client devices can transmit and receive data on the bus.

The serial interface consists of just two signal lines: Serial Clock (SCL) and Serial Data (SDA). The SCL pin is used to receive the clock signal from the host, while the bidirectional SDA pin is used to receive command and data information from the host as well as to send data back to the host. Data are always latched into the AT24CM02 on the rising edge of SCL and always output from the device on the falling edge of SCL. Both the SCL and SDA pins incorporate integrated spike suppression filters and Schmitt Triggers to minimize the effects of input spikes and bus noise.

All command and data information is transferred with the Most Significant bit (MSb) first. During bus communication, one data bit is transmitted every clock cycle, and after eight bits (one byte) of data have been transferred, the receiving device must respond with either an Acknowledge (ACK) or a No-Acknowledge (NACK) response bit during a ninth clock cycle (ACK/NACK clock cycle) generated by the host. Therefore, nine clock cycles are required for every one byte of data transferred. There are no unused clock cycles during any read or write operation; thus, there must not be any interruptions or breaks in the data stream during each data byte transfer and ACK or NACK clock cycle.

During data transfers, data on the SDA pin must change only while SCL is low, and the data must remain stable while SCL is high. If data on the SDA pin changes while SCL is high, then either a Start or a Stop condition will occur. Start and Stop conditions are used to initiate and terminate all serial bus communication between the host and the client devices. The number of data bytes transferred between a Start and a Stop condition is not limited and is determined by the host. For the serial bus to be idle, both the SCL and SDA pins must be in the logic high state simultaneously.

5.1 Clock and Data Transition Requirements

The SDA pin is an open-drain terminal and, therefore, must be pulled high with an external pull-up resistor. SCL is an input pin that can either be driven high or pulled high using an external pull-up resistor. Data on the SDA pin may change only during SCL low time periods. Data changes during SCL high periods will indicate a Start or Stop condition, as defined below. The relationship of the AC timing parameters with respect to SCL and SDA for the AT24CM02 is shown in the timing waveform in [Figure 4-1](#). The AC timing characteristics and specifications are outlined in the [AC Characteristics](#) section.

5.2 Start and Stop Conditions

5.2.1 Start Condition

A Start condition occurs when there is a high-to-low transition on the SDA pin while the SCL pin is at a stable logic '1' state and will bring the device out of Standby mode. The host uses a Start condition to initiate any data transfer sequence; therefore, every command must begin with a Start condition. The device will continuously monitor the SDA and SCL pins for a Start condition but will not respond unless one is detected. Refer to [Figure 5-1](#) for more details.

5.2.2 Stop Condition

A Stop condition occurs when there is a low-to-high transition on the SDA pin while the SCL pin is stable in the logic '1' state.

The host can use the Stop condition to end a data transfer sequence with the AT24CM02, which will subsequently return to Standby mode. The host can also utilize a repeated Start condition instead of a Stop condition to end the current data transfer if the host will perform another operation. Refer to [Figure 5-1](#) for more details.

5.3 Acknowledge and No-Acknowledge

After every byte of data is received, the receiving device must confirm to the transmitting device that it has successfully received the data byte by responding with what is known as an Acknowledge (ACK). An ACK is accomplished when the transmitting device first releases the SDA line at the falling edge of the eighth clock cycle, followed by the receiving device responding with a logic '0' during the entire high period of the ninth clock cycle.

When the AT24CM02 is transmitting data to the host, the host can indicate that it has finished receiving data and wants to end the operation by sending a logic '1' response to the AT24CM02 instead of an ACK response during the ninth clock cycle. This is known as a No-Acknowledge (NACK) and is accomplished by the host sending a logic '1' during the ninth clock cycle, at which point the AT24CM02 will release the SDA line so the host can then generate a Stop condition.

The transmitting device, which can be either the bus host or the Serial EEPROM, must release the SDA line at the falling edge of the eighth clock cycle to allow the receiving device to drive the SDA line to a logic '0' to ACK the previous 8-bit word. The receiving device must release the SDA line at the end of the ninth clock cycle to allow the transmitter to continue sending new data. A timing diagram is provided in [Figure 5-1](#) to better illustrate these requirements.

Figure 5-1. Start Condition, Data Transitions, Stop Condition and Acknowledge

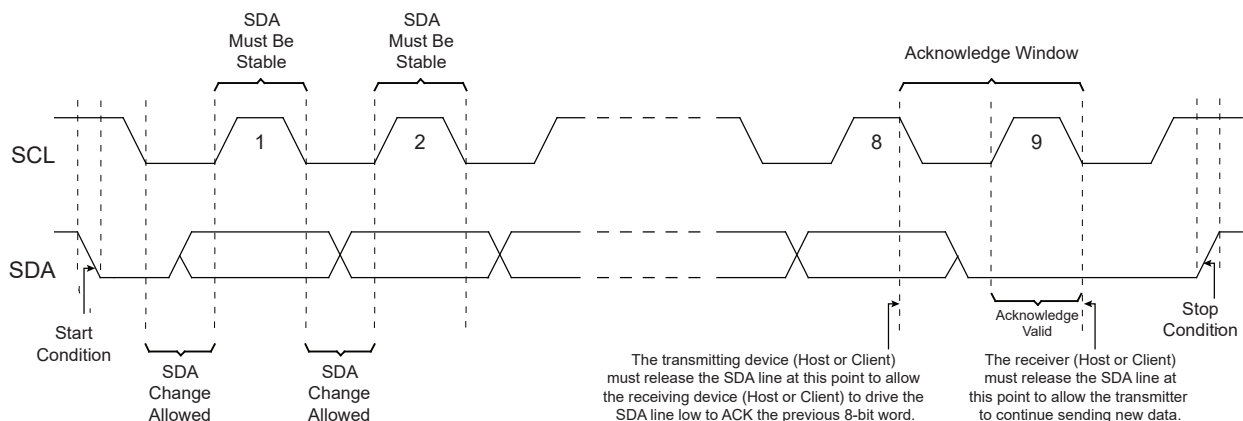

5.4 Standby Mode

The AT24CM02 features a low-power Standby mode that is enabled when any one of the following occurs:

- A valid power-up sequence is performed (see [Power-Up Requirements and Reset Behavior](#)).
- A Stop condition at the end of a valid I²C transaction is received by the device, unless it initiates an internal write cycle (see [Write Operations](#)).
- The completion of an internal write cycle occurs (see [Write Operations](#)).

5.5 Software Reset

After an interruption in protocol, power loss or system Reset, any two-wire device can be protocol reset by clocking SCL until SDA is released by the EEPROM and goes high. The number of clock cycles until SDA is released by the EEPROM will vary. The software Reset sequence should not require more than nine dummy clock cycles. Once the software Reset sequence is complete, a new protocol can be sent to the device by sending a Start condition followed by the protocol. Refer to [Figure 5-2](#) for an illustration.

Figure 5-2. Software Reset

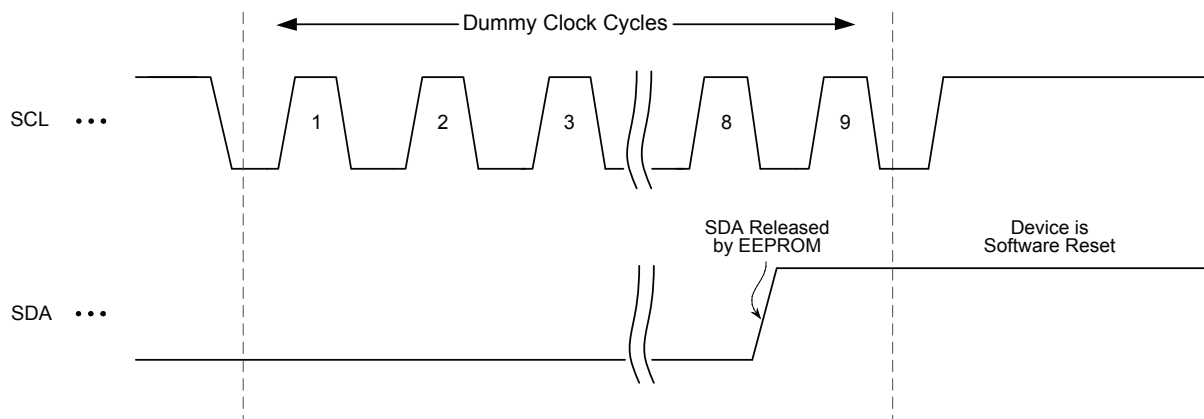

In the event that the device is still non-responsive or remains active on the SDA bus, a power cycle must be used to reset the device (see [Power-Up Requirements and Reset Behavior](#)).

6. Memory Organization

The AT24CM02 is internally organized as 1,024 pages of 256 bytes each.

6.1 Device Addressing

Accessing the device requires an 8-bit device address byte following a Start condition to enable the device for a read or write operation. Since multiple client devices can reside on the serial bus, each client device must have its own unique address so the host can access each device independently.

The Most Significant four bits of the device address byte are referred to as the device type identifier. The device type identifier '1010' (Ah) is required in bits 7-4 of the device address byte (see [Table 6-1](#)).

Following the 4-bit device type identifier is the hardware client address bit, A2. This bit can be used to expand the address space by allowing up to two Serial EEPROM devices on the same bus. The hardware client address bit must correlate with the voltage level on the corresponding hardwired device address input pin A2. The A2 pin uses an internal proprietary circuit that automatically biases the pin to a logic '0' state if the pin is allowed to float. In order to operate in a wide variety of application environments, the pull-down mechanism is intentionally designed to be somewhat strong. Once the pin is biased above the CMOS input buffer's trip point ($\sim 0.5 \times V_{CC}$), the pull-down mechanism disengages. Microchip recommends connecting the A2 pin to a known state whenever possible.

Following the A2 hardware client address bit are A17 and A16 (bit 2 and bit 1 of the device address byte), which are the Most Significant bits of the memory array word address (see [Table 6-1](#)).

The eighth bit (bit 0) of the device address byte is the Read/Write Select bit. A read operation is initiated if this bit is high, and a write operation is initiated if this bit is low.

Upon the successful comparison of the device address byte, the AT24CM02 will return an ACK. If a valid comparison is not made, the device will NACK.

Table 6-1. Device Address Byte

Package	Device Type Identifier				Hardware Client Address Bit	Most Significant Bits of the Word Address		R/W Select
	Bit 7	Bit 6	Bit 5	Bit 4	Bit 3	Bit 2	Bit 1	Bit 0
All Packages	1	0	1	0	A ₂	A17	A16	R/W

For all operations except the current address read, two 8-bit word address bytes must be transmitted to the device immediately following the device address byte. The word address bytes contain the lower 16 significant memory array address bits and are used to specify which byte location in the EEPROM to start reading or writing. See [Table 6-2](#) and [Table 6-3](#) to review their bit positions.

Table 6-2. First Word Address Byte

Bit 7	Bit 6	Bit 5	Bit 4	Bit 3	Bit 2	Bit 1	Bit 0
A15	A14	A13	A12	A11	A10	A9	A8

Table 6-3. Second Word Address Byte

Bit 7	Bit 6	Bit 5	Bit 4	Bit 3	Bit 2	Bit 1	Bit 0
A7	A6	A5	A4	A3	A2	A1	A0

7. Write Operations

All write operations for the AT24CM02 begin with the host sending a Start condition, followed by a device address byte with the R/W bit set to logic '0', and then the word address bytes. The data value(s) to be written to the device immediately follow the word address bytes.

7.1 Byte Write

The AT24CM02 supports the writing of a single 8-bit byte. Selecting a data word in the AT24CM02 requires an 18-bit word address.

Upon receipt of the proper device address and the word address bytes, the EEPROM will send an Acknowledge. The device will then be ready to receive the 8-bit data word. Following receipt of the 8-bit data word, the EEPROM will respond with an ACK. The addressing device, such as a bus host, must then terminate the write operation with a Stop condition. At that time, the EEPROM will enter an internally self-timed write cycle, which will be completed within t_{WR} , while the data word is being programmed into the nonvolatile EEPROM. All inputs are disabled during this write cycle, and the EEPROM will not respond until the write is complete.

Figure 7-1. Byte Write

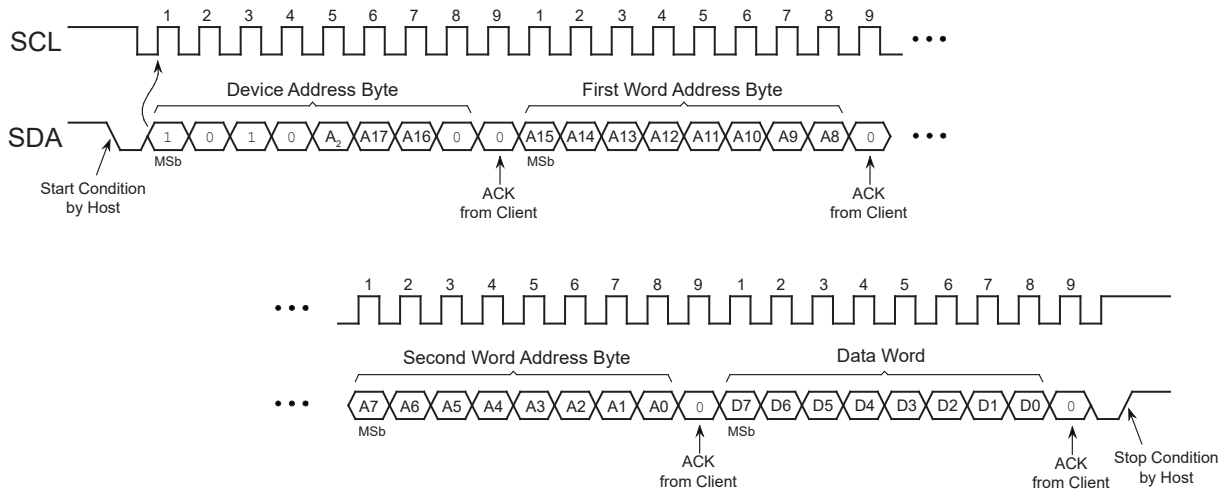

7.2 Page Write

A page write operation allows up to 256 bytes to be written in the same write cycle, provided that all bytes are in the same row of the memory array (where address bits A17 through A8 are the same). Partial page writes of fewer than 256 bytes are also allowed.

A page write is initiated the same way as a byte write, but the bus host does not send a Stop condition after the first data word is clocked in. Instead, after the EEPROM acknowledges receipt of the first data word, the bus host can transmit up to 255 additional data words. The EEPROM will respond with an ACK after each data word is received. Once all data to be written have been sent to the device, the bus host must issue a Stop condition (see Figure 7-2), at which time the internally self-timed write cycle will begin.

The lower eight bits of the word address are internally incremented following the receipt of each data word. The higher-order address bits are not incremented and retain the memory page row location. Page write operations are limited to writing bytes within a single physical page, regardless of the number of bytes actually being written. When the incremented word address reaches the page boundary, the address counter will roll over to the beginning of the same page. Nevertheless, creating a rollover event should be avoided as previously loaded data in the page could become unintentionally altered.

Figure 7-2. Page Write

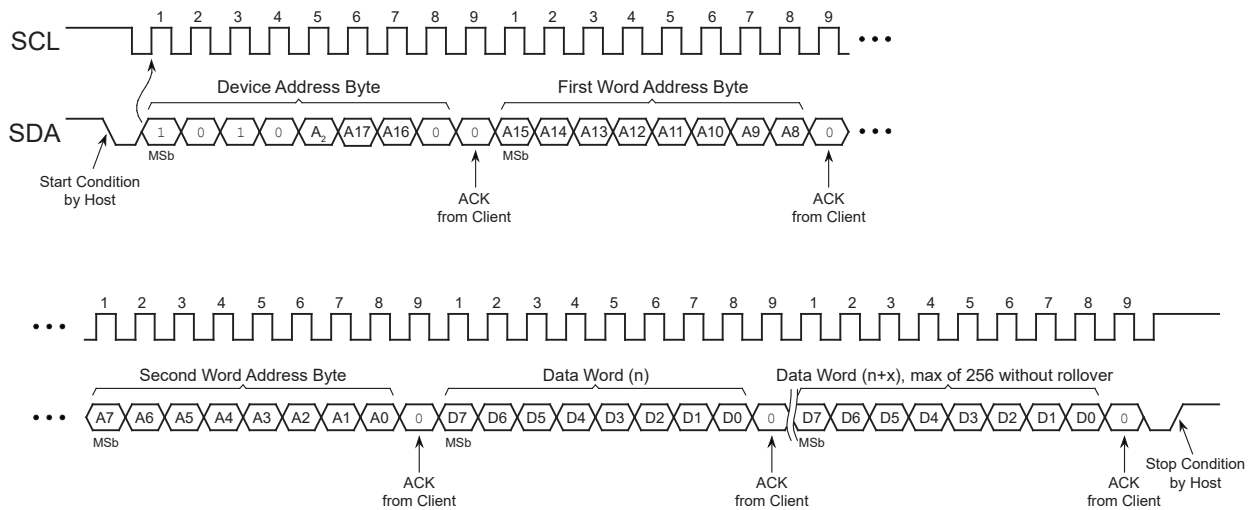

7.3 Internal Writing Methodology

The AT24CM02 incorporates a built-in error detection and correction (EDC) logic scheme. The EEPROM array is internally organized as a group of four connected 8-bit bytes, plus an additional six ECC (Error Correction Code) bits of EEPROM. These 38 bits are referred to as the internal physical data word. During a read sequence, the EDC logic compares each 4-byte physical data word with its corresponding six ECC bits. If a single bit out of the 4-byte region reads incorrectly, the EDC logic will detect the bad bit and replace it with a correct value before the data are serially clocked out. This architecture significantly improves the reliability of the AT24CM02 compared to an implementation that does not utilize EDC.

It is important to note that data are always physically written to the part at the internal physical data word level, regardless of the number of bytes written. Writing single bytes is still possible with the byte write operation, but internally, the other three bytes within that 4-byte location where the single byte was written, along with the six ECC bits, will be updated. Due to this architecture, the AT24CM02 EEPROM write endurance is rated at the internal physical data word level (4-byte word). The system designer needs to optimize the application's writing algorithms to observe these internal word boundaries in order to reach the endurance rating.

7.4 Acknowledge Polling

An Acknowledge Polling routine can be implemented to optimize time-sensitive applications that would prefer not to wait the fixed maximum write cycle time (t_{WR}). This method allows the application to immediately know when the Serial EEPROM write cycle has completed so a subsequent operation can be started.

Once the internally self-timed write cycle has started, an Acknowledge Polling routine can be initiated. This involves repeatedly sending a Start condition followed by a valid device address byte with the R/\overline{W} bit set to logic '0'. The device will not respond with an ACK while the write cycle is ongoing. Once the internal write cycle has completed, the EEPROM will respond with an ACK, allowing a new read or write operation to be immediately initiated. A flowchart has been included in [Figure 7-3](#) to better illustrate this technique.

Figure 7-3. Acknowledge Polling Flowchart

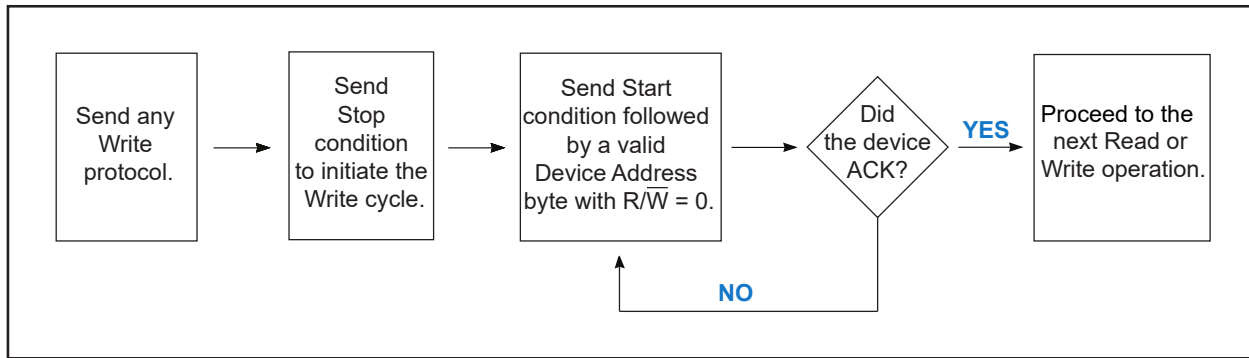

7.5 Write Cycle Timing

The length of the self-timed write cycle (t_{WR}) is defined as the amount of time from the Stop condition, which begins the internal write cycle, to the Start condition of the first device address byte sent to the AT24CM02, to which it subsequently responds with an ACK. Figure 7-4 shows this measurement. During the internally self-timed write cycle, any attempts to read from or write to the memory array will not be processed.

Figure 7-4. Write Cycle Timing

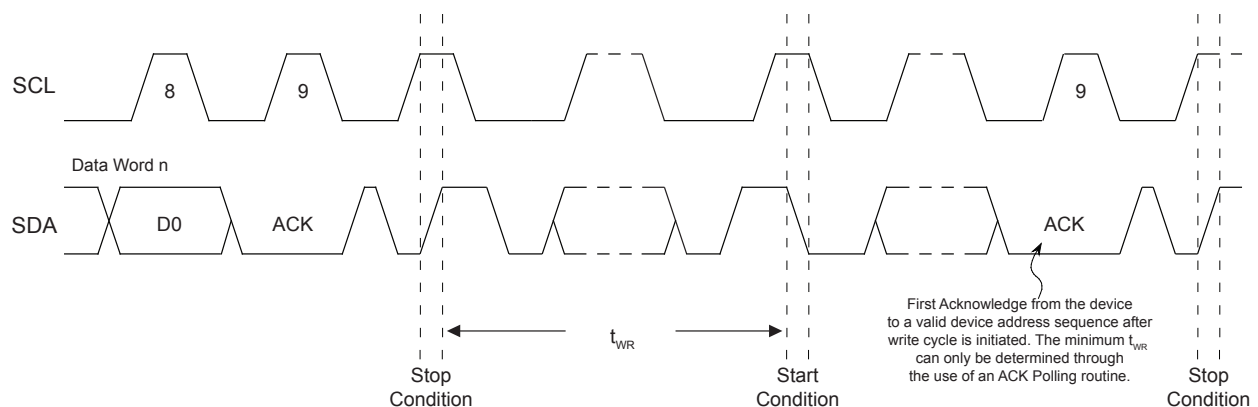

7.6 Write Protection

The AT24CM02 utilizes a hardware data protection scheme that allows the user to write-protect the entire memory contents when the WP pin is at V_{CC} (or a valid V_{IH}). No write protection will be set if the WP pin is at GND or left floating.

Table 7-1. AT24CM02 Write-Protect Behavior

WP Pin Voltage	Part of the Array Protected
V_{CC}	Full Array
GND	None — Write Protection Not Enabled

The status of the WP pin is sampled at the Stop condition for every byte write or page write operation prior to the start of an internally self-timed write cycle. Changing the state of the WP pin after the Stop condition has been sent will not alter or interrupt the execution of the write cycle. The state of the WP pin must be valid with respect to the associated setup ($t_{SU.WP}$) and hold ($t_{HD.WP}$) timings, as shown in Figure 7-5. The WP setup time is the amount of time that the state of the WP pin must be stable before the Stop condition is issued. The WP hold time is the amount of time after the Stop condition during which the WP must remain stable (see Table 4-3, AC Characteristics, for the timing specs for $t_{HD.WP}$ and $t_{SU.WP}$).

If an attempt is made to write to the device while the WP pin has been asserted, the device will acknowledge the device address, word address and data bytes. However, no write cycle will occur when the Stop condition is issued. The device will immediately be ready to accept a new read or write command.

Figure 7-5. Write-Protect Setup and Hold Timing

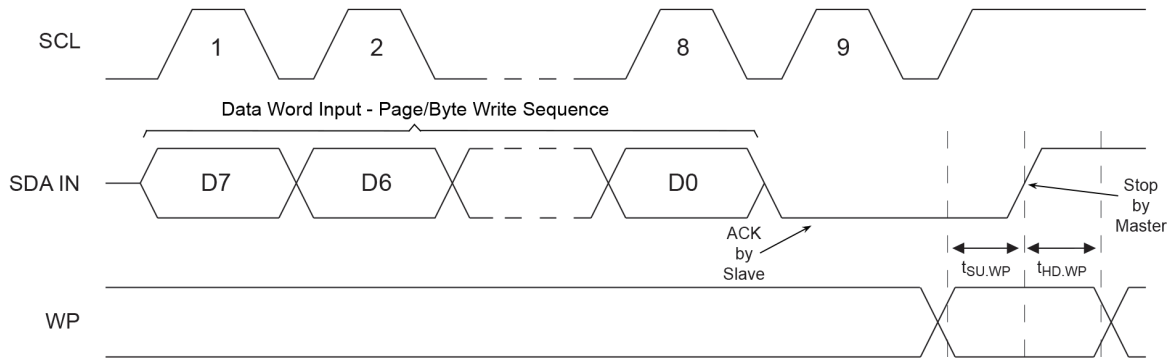

8. Read Operations

Read operations are initiated the same way as write operations, with the exception that the Read/Write Select bit in the device address byte must be a logic '1'. There are three read operations:

- Current Address Read
- Random Address Read
- Sequential Read

8.1 Current Address Read

The internal data word address counter maintains the last address accessed during the last read or write operation, incremented by one. This address remains valid between operations as long as the V_{CC} is maintained to the part. The address rollover during a read is from the last byte of the last page to the first byte of the first page of the memory.

A current address read operation outputs data according to the location of the internal data word address counter. This is initiated with a Start condition, followed by a valid device address byte with the R/W bit set to logic '1'. The device will ACK this sequence, and the current address data word is serially clocked out on the SDA line. All types of read operations will terminate if the bus host does not respond with an ACK (it NACKs) during the ninth clock cycle. After the NACK response, the host may send a Stop condition to complete the protocol, or it can send a Start condition to begin the next sequence.

While the two most significant bits of the data word address (A17 and A16) are embedded in the Device Address byte, they do not take precedence over the existing values of the A17 and A16 bits in the internal address counter during a Current Address Read and are therefore represented as don't care bits, as shown in Figure 8-1.

Figure 8-1. Current Address Read

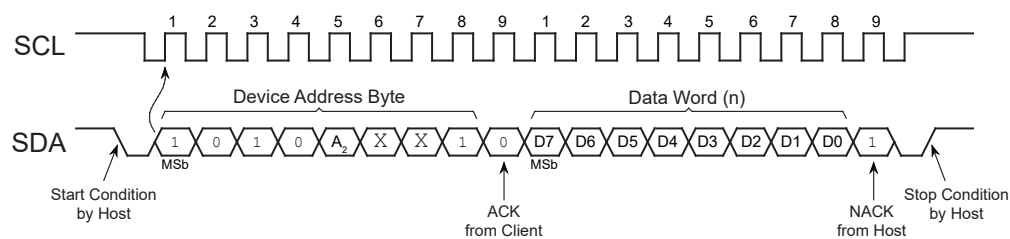

Note: X= "don't care"

8.2 Random Read

A random read begins in the same way as a byte write operation does to load in a new data word address. This is known as a "dummy write" sequence; however, the data byte and the Stop condition of the byte write must be omitted to prevent the part from entering an internal write cycle. Once the device address and word address are clocked in and acknowledged by the EEPROM, the bus host must generate another Start condition. The bus host now initiates a current address read by sending a Start condition, followed by a valid device address byte with the R/W bit set to logic '1'. While the two most significant bits of the data word address (A17 and A16) are embedded in the Device Address byte, they will not take precedence over the existing values of the A17 and A16 bits in the internal address counter set during the dummy write and are represented as don't care bits in Figure 8-2.

The EEPROM will ACK the device address and serially clock out the data word on the SDA line. All types of read operations will be terminated if the bus host does not respond with an ACK (it

NACKs) during the ninth clock cycle. After the NACK response, the host may send a Stop condition to complete the protocol, or it can send a Start condition to begin the next sequence.

Figure 8-2. Random Read

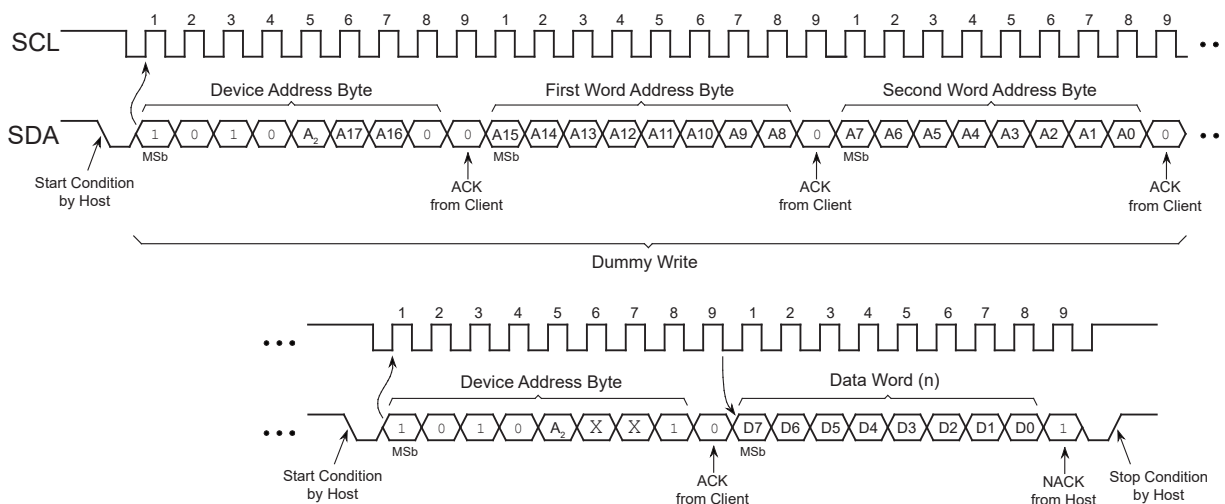

Note: x = "don't care"

8.3 Sequential Read

Sequential Reads are initiated by either a Current Address Read or a Random Read that have been described previously. As such, the A17 and A16 bits sent in the Device Address byte are don't care values as they will not change the values in the address pointer. As long as the EEPROM receives an ACK, it will continue to increment the word address and serially clock out sequential data words. When the maximum memory address is reached, the data word address will roll over, and the sequential read will continue from the beginning of the memory array. All types of read operations will be terminated if the bus host does not respond with an ACK (it NACKs) during the ninth clock cycle. After the NACK response, the host may send a Stop condition to complete the protocol, or it can send a Start condition to begin the next sequence.

Figure 8-3. Sequential Read

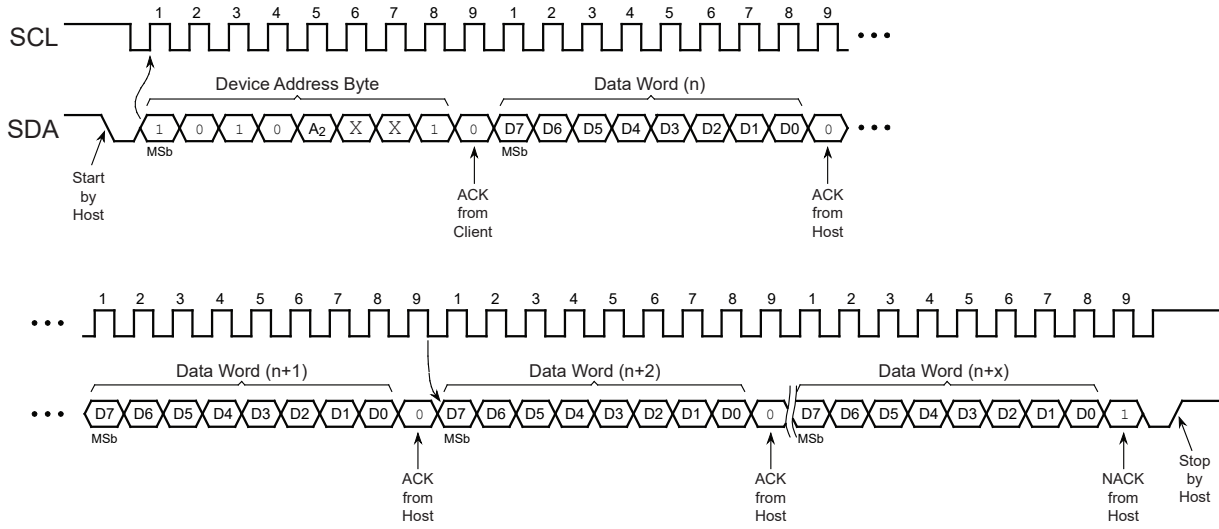

Note: X = "don't care"

9. Device Default Condition from Microchip

The AT24CM02 is delivered with the EEPROM array set to logic '1', resulting in FFh data in all locations.

10. Packaging Information

10.1 Package Marking Information

AT24CM02: Package Marking Information

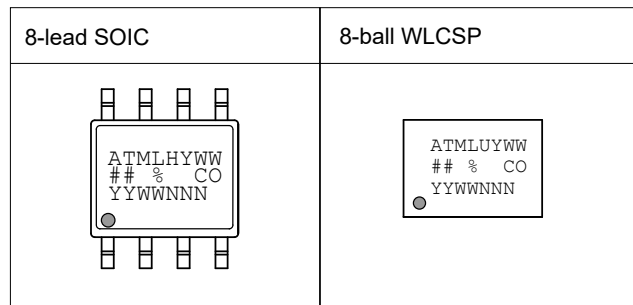

Note 1: ● designates pin 1
Note 2: Package drawings are not to scale

Catalog Number Truncation		
AT24CM02		Truncation Code ##: 2H
Date Codes	Voltages	
Y = Year code (last digit of calendar year) YY = Year code (last 2 digits of calendar year) WW = Week code (week of January 1 is week '01')	% = Minimum Voltage M: 1.7V min D: 2.5V min	
Country of Origin	Device Grade	Atmel Truncation
CO = Country of Origin	H or U: Industrial Grade	AT: Atmel ATM: Atmel ATML: Atmel
Lot Number or Trace Code		
NNN = Alphanumeric Trace Code (2 Characters for small packages)		

8-Lead Plastic Small Outline (SN) - Narrow, 3.90 mm (.150 In.) Body [SOIC]

Note: For the most current package drawings, please see the Microchip Packaging Specification located at <http://www.microchip.com/packaging>

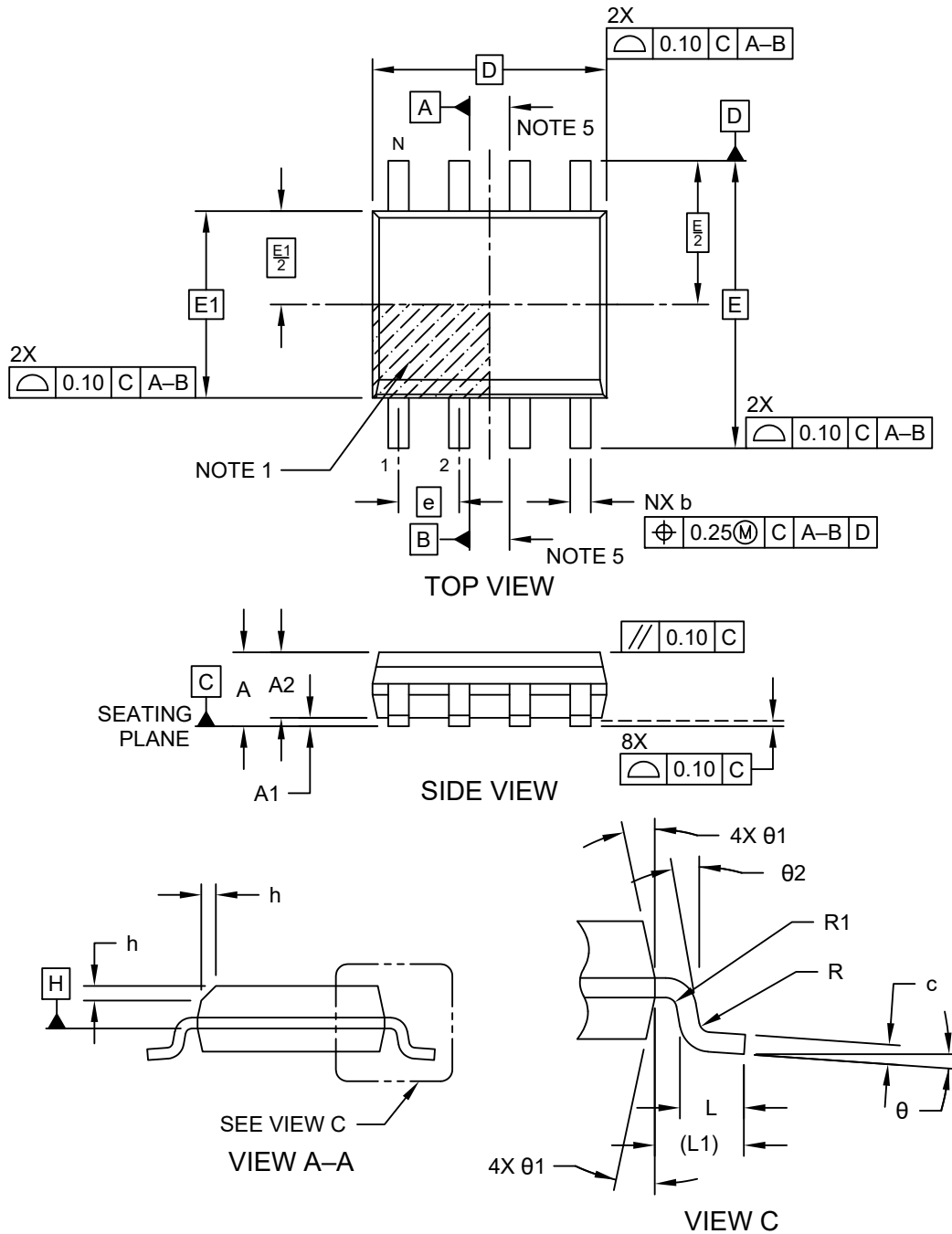

Microchip Technology Drawing No. C04-057-SN Rev K Sheet 1 of 2

8-Lead Plastic Small Outline (SN) - Narrow, 3.90 mm (.150 In.) Body [SOIC]

Note: For the most current package drawings, please see the Microchip Packaging Specification located at <http://www.microchip.com/packaging>

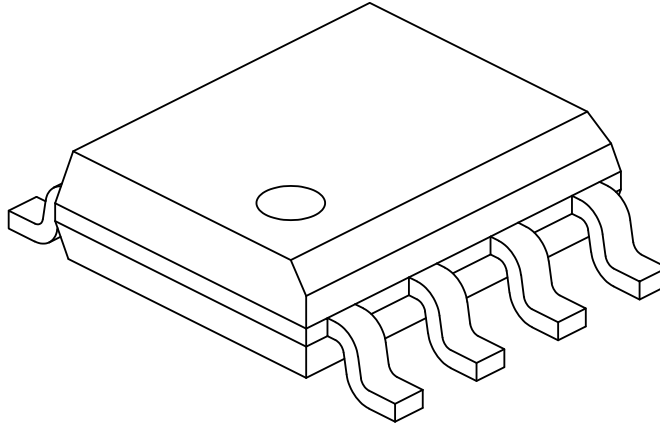

Dimension Limits	Units	MILLIMETERS		
		MIN	NOM	MAX
Number of Pins	N	8		
Pitch	e	1.27 BSC		
Overall Height	A	–	–	1.75
Molded Package Thickness	A2	1.25	–	–
Standoff §	A1	0.10	–	0.25
Overall Width	E	6.00 BSC		
Molded Package Width	E1	3.90 BSC		
Overall Length	D	4.90 BSC		
Chamfer (Optional)	h	0.25	–	0.50
Foot Length	L	0.40	–	1.27
Footprint	L1	1.04 REF		
Lead Thickness	c	0.17	–	0.25
Lead Width	b	0.31	–	0.51
Lead Bend Radius	R	0.07	–	–
Lead Bend Radius	R1	0.07	–	–
Foot Angle	θ	0°	–	8°
Mold Draft Angle	θ1	5°	–	15°
Lead Angle	θ2	0°	–	–

Notes:

- Pin 1 visual index feature may vary, but must be located within the hatched area.
- § Significant Characteristic
- Dimensions D and E1 do not include mold flash or protrusions. Mold flash or protrusions shall not exceed 0.15mm per side.
- Dimensioning and tolerancing per ASME Y14.5M
 - BSC: Basic Dimension. Theoretically exact value shown without tolerances.
 - REF: Reference Dimension, usually without tolerance, for information purposes only.
- Datums A & B to be determined at Datum H.

Microchip Technology Drawing No. C04-057-SN Rev K Sheet 2 of 2

8-Lead Plastic Small Outline (SN) - Narrow, 3.90 mm (.150 In.) Body [SOIC]

Note: For the most current package drawings, please see the Microchip Packaging Specification located at <http://www.microchip.com/packaging>

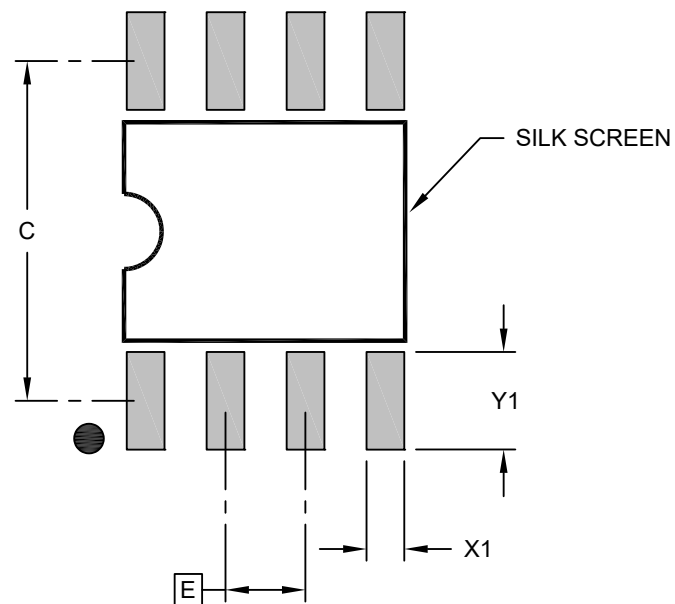

RECOMMENDED LAND PATTERN

		Units	MILLIMETERS		
Dimension Limits			MIN	NOM	MAX
Contact Pitch	E		1.27 BSC		
Contact Pad Spacing	C		5.40		
Contact Pad Width (X8)	X1				0.60
Contact Pad Length (X8)	Y1				1.55

Notes:

1. Dimensioning and tolerancing per ASME Y14.5M

BSC: Basic Dimension. Theoretically exact value shown without tolerances.

Microchip Technology Drawing C04-2057-SN Rev K

8-Ball Wafer Level Chip Scale Package (FEB) - [WLCSP]

Note: For the most current package drawings, please see the Microchip Packaging Specification located at <http://www.microchip.com/packaging>

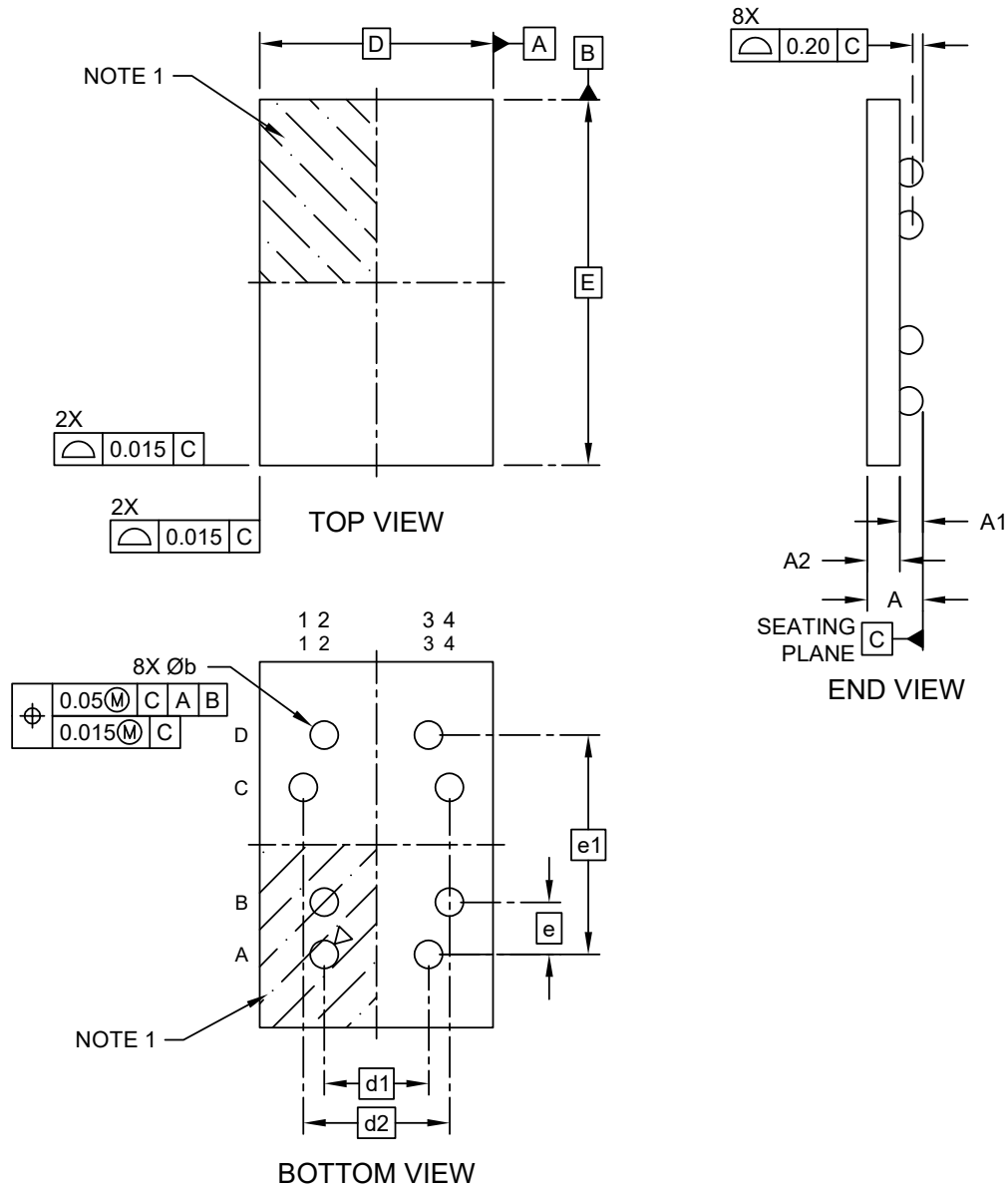

Microchip Technology Drawing C04-21235-DS Rev A Sheet 1 of 2

8-Ball Wafer Level Chip Scale Package (FEB) - [WLCSP]

Note: For the most current package drawings, please see the Microchip Packaging Specification located at <http://www.microchip.com/packaging>

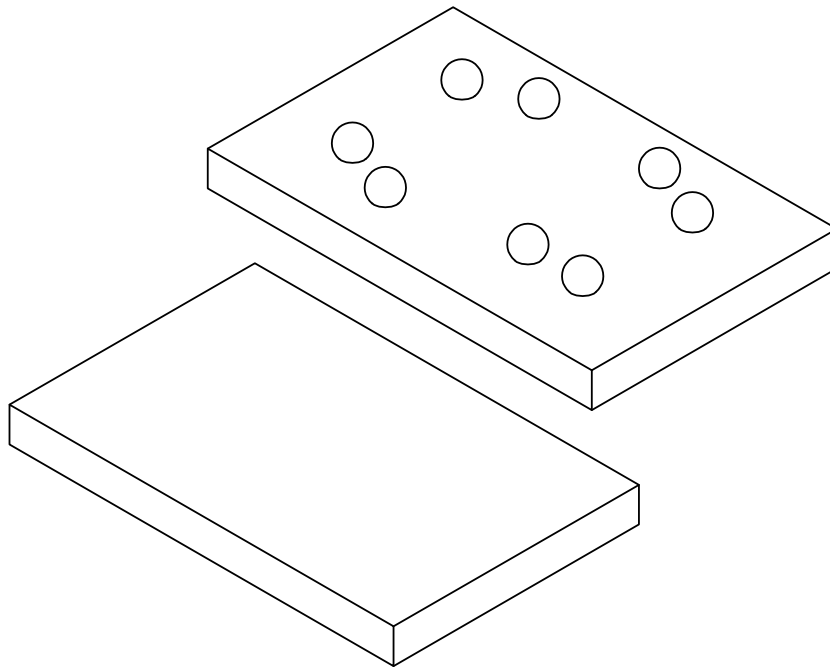

Dimension Limits	Units	MILLIMETERS		
		MIN	NOM	MAX
Number of Terminals	N	8		
Ball Spacing	e	0.50 BSC		
Ball Spacing	e1	2.10 BSC		
Overall Height	A	0.456	0.495	0.534
Ball Height	A1	–	0.190	–
Die Thickness	A2	0.305 REF		
Overall Length	D	Contact Microchip for Details		
Ball Spacing	d1	1.00 BSC		
Ball Spacing	d2	1.40 BSC		
Overall Width	E	Contact Microchip for Details		
Ball Diameter	b	–	0.27	–

Notes:

1. Pin 1 visual index feature may vary, but must be located within the hatched area.
2. Dimensioning and tolerancing per ASME Y14.5M
 BSC: Basic Dimension. Theoretically exact value shown without tolerances.
 REF: Reference Dimension, usually without tolerance, for information purposes only.

Microchip Technology Drawing C04-21235-DS Rev A Sheet 2 of 2

8-Ball Wafer Level Chip Scale Package (FEB) - [WLCSP]

Note: For the most current package drawings, please see the Microchip Packaging Specification located at <http://www.microchip.com/packaging>

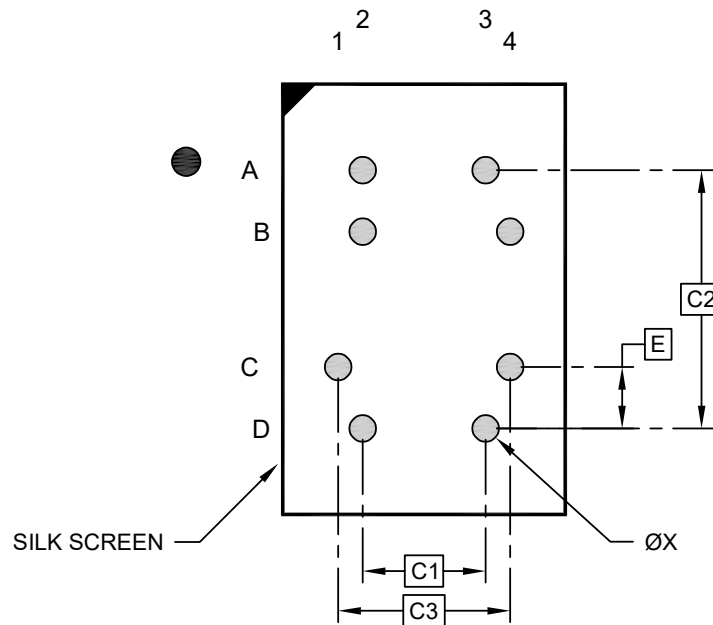

RECOMMENDED LAND PATTERN

Dimension Limits	Units	MILLIMETERS		
		MIN	NOM	MAX
Contact Pitch	E	0.50 BSC		
Contact Pad Spacing	C1	1.00 BSC		
Contact Pad Spacing	C3	1.40 BSC		
Contact Pad Spacing	C2	2.10 BSC		
Contact Pad Width (Xnn)	X1	0.22		

Notes:

- Dimensioning and tolerancing per ASME Y14.5M
BSC: Basic Dimension. Theoretically exact value shown without tolerances.

Microchip Technology Drawing C04-21235-DS Rev A

Note: For the most current package drawings, please see the Microchip Packaging Specification located at <http://www.microchip.com/packaging>.

11. Revision History

Revision D (April 2024)

Replaced Atmel WLCSP drawing with Microchip version (no change to form, fit or function).
Corrected embedded addressing bits in waveforms. Removed typical DC Characteristics parameters.

Revision C (March 2021)

Corrected SOIC Package Type drawing. Updated the SOIC package drawing.

Revision B (December 2020)

Updated Revision History to latest template. Removed thin height WLCSP product offering. Replaced terminology "Master" and "Slave" with "Host" and "Client", respectively.

Revision A (May 2019)

Updated to Microchip template. Microchip DS20006197 replaces Atmel document 8812. Corrected t_{LOW} typo from 400 ns to 500 ns. Corrected t_{AA} typo from 550 ns to 450 ns. Updated Part Marking Information. Updated the "Software Reset" section. Added ESD rating. Removed lead finish designation. Updated trace code format in package markings. Updated section content throughout for clarification. Updated SOIC package drawing to Microchip format.

Atmel Document 8828 Revision E (January 2017)

Updated Power-on Requirements and Reset Behavior section.

Atmel Document 8828 Revision D (May 2016)

Added the 8U-18 standard thickness WLCSP package option. Updated the "Clock and Data Transition Requirements" section and the "DC Characteristics" table.

Atmel Document 8828 Revision C (November 2015)

Corrected 8-ball WLCSP pinout.

Atmel Document 8828 Revision B (August 2015)

Updated the 8U-11 package drawing, data retention discrepancy and 8-ball pinout.

Atmel Document 8828 Revision A (May 2015)

Initial document release.

Microchip Information

The Microchip Website

Microchip provides online support via our website at www.microchip.com/. This website is used to make files and information easily available to customers. Some of the content available includes:

- **Product Support** – Data sheets and errata, application notes and sample programs, design resources, user's guides and hardware support documents, latest software releases and archived software
- **General Technical Support** – Frequently Asked Questions (FAQs), technical support requests, online discussion groups, Microchip design partner program member listing
- **Business of Microchip** – Product selector and ordering guides, latest Microchip press releases, listing of seminars and events, listings of Microchip sales offices, distributors and factory representatives

Product Change Notification Service

Microchip's product change notification service helps keep customers current on Microchip products. Subscribers will receive email notification whenever there are changes, updates, revisions or errata related to a specified product family or development tool of interest.

To register, go to www.microchip.com/pcn and follow the registration instructions.

Customer Support

Users of Microchip products can receive assistance through several channels:

- Distributor or Representative
- Local Sales Office
- Embedded Solutions Engineer (ESE)
- Technical Support

Customers should contact their distributor, representative or ESE for support. Local sales offices are also available to help customers. A listing of sales offices and locations is included in this document.

Technical support is available through the website at: www.microchip.com/support

Product Identification System

To order or obtain information, e.g., on pricing or delivery, refer to the factory or the listed sales office.

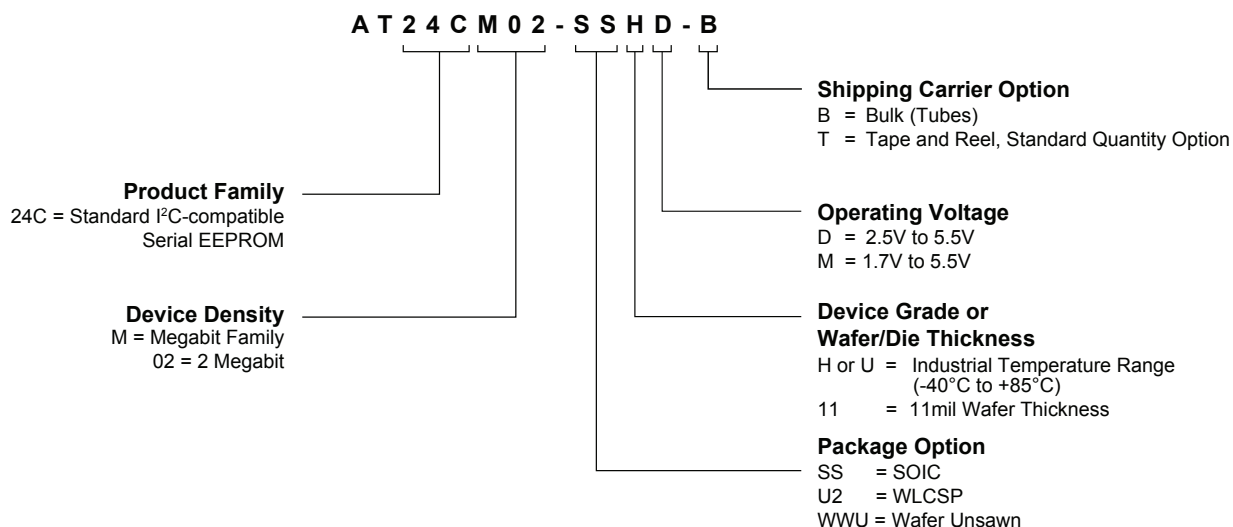

Examples

Device	Package	Package Drawing Code	Package Option	Voltage	Shipping Carrier Option	Device Grade
AT24CM02-SSHM-B	SOIC	SN	SS	1.7V to 5.5V	Bulk (Tubes)	Industrial Temperature (-40°C to +85°C)
AT24CM02-SSHM-T	SOIC	SN	SS	1.7V to 5.5V	Tape and Reel	
AT24CM02-SSHD-B	SOIC	SN	SS	2.5V to 5.5V	Bulk (Tubes)	
AT24CM02-SSHD-T	SOIC	SN	SS	2.5V to 5.5V	Tape and Reel	
AT24CM02-U2UM-T ⁽¹⁾	WLCSP	8U-18	U2	1.7V to 5.5V	Tape and Reel	

Note:

- CAUTION:** Exposure to ultraviolet (UV) light can degrade the data stored in EEPROM cells. Therefore, customers who use a WLCSP package or the product at a die level must ensure that exposure to ultraviolet light does **not** occur.

Microchip Devices Code Protection Feature

Note the following details of the code protection feature on Microchip products:

- Microchip products meet the specifications contained in their particular Microchip Data Sheet.
- Microchip believes that its family of products is secure when used in the intended manner, within operating specifications, and under normal conditions.
- Microchip values and aggressively protects its intellectual property rights. Attempts to breach the code protection features of Microchip product is strictly prohibited and may violate the Digital Millennium Copyright Act.
- Neither Microchip nor any other semiconductor manufacturer can guarantee the security of its code. Code protection does not mean that we are guaranteeing the product is “unbreakable”.

Code protection is constantly evolving. Microchip is committed to continuously improving the code protection features of our products.

Legal Notice

This publication and the information herein may be used only with Microchip products, including to design, test, and integrate Microchip products with your application. Use of this information in any other manner violates these terms. Information regarding device applications is provided only for your convenience and may be superseded by updates. It is your responsibility to ensure that your application meets with your specifications. Contact your local Microchip sales office for additional support or, obtain additional support at www.microchip.com/en-us/support/design-help/client-support-services.

THIS INFORMATION IS PROVIDED BY MICROCHIP "AS IS". MICROCHIP MAKES NO REPRESENTATIONS OR WARRANTIES OF ANY KIND WHETHER EXPRESS OR IMPLIED, WRITTEN OR ORAL, STATUTORY OR OTHERWISE, RELATED TO THE INFORMATION INCLUDING BUT NOT LIMITED TO ANY IMPLIED WARRANTIES OF NON-INFRINGEMENT, MERCHANTABILITY, AND FITNESS FOR A PARTICULAR PURPOSE, OR WARRANTIES RELATED TO ITS CONDITION, QUALITY, OR PERFORMANCE.

IN NO EVENT WILL MICROCHIP BE LIABLE FOR ANY INDIRECT, SPECIAL, PUNITIVE, INCIDENTAL, OR CONSEQUENTIAL LOSS, DAMAGE, COST, OR EXPENSE OF ANY KIND WHATSOEVER RELATED TO THE INFORMATION OR ITS USE, HOWEVER CAUSED, EVEN IF MICROCHIP HAS BEEN ADVISED OF THE POSSIBILITY OR THE DAMAGES ARE FORESEEABLE. TO THE FULLEST EXTENT ALLOWED BY LAW, MICROCHIP'S TOTAL LIABILITY ON ALL CLAIMS IN ANY WAY RELATED TO THE INFORMATION OR ITS USE WILL NOT EXCEED THE AMOUNT OF FEES, IF ANY, THAT YOU HAVE PAID DIRECTLY TO MICROCHIP FOR THE INFORMATION.

Use of Microchip devices in life support and/or safety applications is entirely at the buyer's risk, and the buyer agrees to defend, indemnify and hold harmless Microchip from any and all damages, claims, suits, or expenses resulting from such use. No licenses are conveyed, implicitly or otherwise, under any Microchip intellectual property rights unless otherwise stated.

Trademarks

The Microchip name and logo, the Microchip logo, Adaptec, AVR, AVR logo, AVR Freaks, BesTime, BitCloud, CryptoMemory, CryptoRF, dsPIC, flexPWR, HELDO, IGLOO, JukeBlox, KeeLoq, Kleer, LANCheck, LinkMD, maXStylus, maXTouch, MediaLB, megaAVR, Microsemi, Microsemi logo, MOST, MOST logo, MPLAB, OptoLyzer, PIC, picoPower, PICSTART, PIC32 logo, PolarFire, Prochip Designer, QTouch, SAM-BA, SenGenuity, SpyNIC, SST, SST Logo, SuperFlash, Symmetricom, SyncServer, Tachyon, TimeSource, tinyAVR, UNI/O, Vectron, and XMEGA are registered trademarks of Microchip Technology Incorporated in the U.S.A. and other countries.

AgileSwitch, ClockWorks, The Embedded Control Solutions Company, EtherSynch, Flashtec, Hyper Speed Control, HyperLight Load, Libero, motorBench, mTouch, Powermite 3, Precision Edge, ProASIC, ProASIC Plus, ProASIC Plus logo, Quiet-Wire, SmartFusion, SyncWorld, TimeCesium, TimeHub, TimePictra, TimeProvider, and ZL are registered trademarks of Microchip Technology Incorporated in the U.S.A.

Adjacent Key Suppression, AKS, Analog-for-the-Digital Age, Any Capacitor, AnyIn, AnyOut, Augmented Switching, BlueSky, BodyCom, Clockstudio, CodeGuard, CryptoAuthentication, CryptoAutomotive, CryptoCompanion, CryptoController, dsPICDEM, dsPICDEM.net, Dynamic Average Matching, DAM, ECAN, Espresso T1S, EtherGREEN, EyeOpen, GridTime, IdealBridge, IGaT, In-Circuit Serial Programming, ICSP, INICnet, Intelligent Paralleling, IntellIMOS, Inter-Chip Connectivity, JitterBlocker, Knob-on-Display, MarginLink, maxCrypto, maxView, memBrain, Mindi, MiWi, MPASM, MPF, MPLAB Certified logo, MPLIB, MPLINK, mSiC, MultiTRAK, NetDetach, Omniscient Code Generation, PICDEM, PICDEM.net, PICkit, PICtail, Power MOS IV, Power MOS 7, PowerSmart, PureSilicon, QMatrix, REAL ICE, Ripple Blocker, RTAX, RTG4, SAM-ICE, Serial Quad I/O, simpleMAP, SimpliPHY, SmartBuffer, SmartHLS, SMART-I.S., storClad, SQL, SuperSwitcher, SuperSwitcher II, Switchtec, SynchroPHY, Total Endurance, Trusted Time, TSHARC, Turing, USBCheck, VariSense,

VectorBlox, VeriPHY, ViewSpan, WiperLock, XpressConnect, and ZENA are trademarks of Microchip Technology Incorporated in the U.S.A. and other countries.

SQTP is a service mark of Microchip Technology Incorporated in the U.S.A.

The Adaptec logo, Frequency on Demand, Silicon Storage Technology, and Symmcom are registered trademarks of Microchip Technology Inc. in other countries.

GestIC is a registered trademark of Microchip Technology Germany II GmbH & Co. KG, a subsidiary of Microchip Technology Inc., in other countries.

All other trademarks mentioned herein are property of their respective companies.

© 2019-2024, Microchip Technology Incorporated and its subsidiaries. All Rights Reserved.

ISBN: 978-1-6683-4308-1

AMBA, Arm, Arm7, Arm7TDMI, Arm9, Arm11, Artisan, big.LITTLE, Cordio, CoreLink, CoreSight, Cortex, DesignStart, DynamIQ, Jazelle, Keil, Mali, Mbed, Mbed Enabled, NEON, POP, RealView, SecurCore, Socrates, Thumb, TrustZone, ULINK, ULINK2, ULINK-ME, ULINK-PLUS, ULINKpro, μ Vision, Versatile are trademarks or registered trademarks of Arm Limited (or its subsidiaries) in the US and/or elsewhere.

Quality Management System

For information regarding Microchip's Quality Management Systems, please visit www.microchip.com/quality.

Worldwide Sales and Service

AMERICAS	ASIA/PACIFIC	ASIA/PACIFIC	EUROPE
<p>Corporate Office 2355 West Chandler Blvd. Chandler, AZ 85224-6199 Tel: 480-792-7200 Fax: 480-792-7277 Technical Support: www.microchip.com/support Web Address: www.microchip.com</p> <p>Atlanta Duluth, GA Tel: 678-957-9614 Fax: 678-957-1455</p> <p>Austin, TX Tel: 512-257-3370</p> <p>Boston Westborough, MA Tel: 774-760-0087 Fax: 774-760-0088</p> <p>Chicago Itasca, IL Tel: 630-285-0071 Fax: 630-285-0075</p> <p>Dallas Addison, TX Tel: 972-818-7423 Fax: 972-818-2924</p> <p>Detroit Novi, MI Tel: 248-848-4000</p> <p>Houston, TX Tel: 281-894-5983</p> <p>Indianapolis Noblesville, IN Tel: 317-773-8323 Fax: 317-773-5453 Tel: 317-536-2380</p> <p>Los Angeles Mission Viejo, CA Tel: 949-462-9523 Fax: 949-462-9608 Tel: 951-273-7800</p> <p>Raleigh, NC Tel: 919-844-7510</p> <p>New York, NY Tel: 631-435-6000</p> <p>San Jose, CA Tel: 408-735-9110 Tel: 408-436-4270</p> <p>Canada - Toronto Tel: 905-695-1980 Fax: 905-695-2078</p>	<p>Australia - Sydney Tel: 61-2-9868-6733</p> <p>China - Beijing Tel: 86-10-8569-7000</p> <p>China - Chengdu Tel: 86-28-8665-5511</p> <p>China - Chongqing Tel: 86-23-8980-9588</p> <p>China - Dongguan Tel: 86-769-8702-9880</p> <p>China - Guangzhou Tel: 86-20-8755-8029</p> <p>China - Hangzhou Tel: 86-571-8792-8115</p> <p>China - Hong Kong SAR Tel: 852-2943-5100</p> <p>China - Nanjing Tel: 86-25-8473-2460</p> <p>China - Qingdao Tel: 86-532-8502-7355</p> <p>China - Shanghai Tel: 86-21-3326-8000</p> <p>China - Shenyang Tel: 86-24-2334-2829</p> <p>China - Shenzhen Tel: 86-755-8864-2200</p> <p>China - Suzhou Tel: 86-186-6233-1526</p> <p>China - Wuhan Tel: 86-27-5980-5300</p> <p>China - Xian Tel: 86-29-8833-7252</p> <p>China - Xiamen Tel: 86-592-2388138</p> <p>China - Zhuhai Tel: 86-756-3210040</p>	<p>India - Bangalore Tel: 91-80-3090-4444</p> <p>India - New Delhi Tel: 91-11-4160-8631</p> <p>India - Pune Tel: 91-20-4121-0141</p> <p>Japan - Osaka Tel: 81-6-6152-7160</p> <p>Japan - Tokyo Tel: 81-3-6880-3770</p> <p>Korea - Daegu Tel: 82-53-744-4301</p> <p>Korea - Seoul Tel: 82-2-554-7200</p> <p>Malaysia - Kuala Lumpur Tel: 60-3-7651-7906</p> <p>Malaysia - Penang Tel: 60-4-227-8870</p> <p>Philippines - Manila Tel: 63-2-634-9065</p> <p>Singapore Tel: 65-6334-8870</p> <p>Taiwan - Hsin Chu Tel: 886-3-577-8366</p> <p>Taiwan - Kaohsiung Tel: 886-7-213-7830</p> <p>Taiwan - Taipei Tel: 886-2-2508-8600</p> <p>Thailand - Bangkok Tel: 66-2-694-1351</p> <p>Vietnam - Ho Chi Minh Tel: 84-28-5448-2100</p>	<p>Austria - Wels Tel: 43-7242-2244-39 Fax: 43-7242-2244-393</p> <p>Denmark - Copenhagen Tel: 45-4485-5910 Fax: 45-4485-2829</p> <p>Finland - Espoo Tel: 358-9-4520-820</p> <p>France - Paris Tel: 33-1-69-53-63-20 Fax: 33-1-69-30-90-79</p> <p>Germany - Garching Tel: 49-8931-9700</p> <p>Germany - Haan Tel: 49-2129-3766400</p> <p>Germany - Heilbronn Tel: 49-7131-72400</p> <p>Germany - Karlsruhe Tel: 49-721-625370</p> <p>Germany - Munich Tel: 49-89-627-144-0 Fax: 49-89-627-144-44</p> <p>Germany - Rosenheim Tel: 49-8031-354-560</p> <p>Israel - Hod Hasharon Tel: 972-9-775-5100</p> <p>Italy - Milan Tel: 39-0331-742611 Fax: 39-0331-466781</p> <p>Italy - Padova Tel: 39-049-7625286</p> <p>Netherlands - Drunen Tel: 31-416-690399 Fax: 31-416-690340</p> <p>Norway - Trondheim Tel: 47-72884388</p> <p>Poland - Warsaw Tel: 48-22-3325737</p> <p>Romania - Bucharest Tel: 40-21-407-87-50</p> <p>Spain - Madrid Tel: 34-91-708-08-90 Fax: 34-91-708-08-91</p> <p>Sweden - Gothenberg Tel: 46-31-704-60-40</p> <p>Sweden - Stockholm Tel: 46-8-5090-4654</p> <p>UK - Wokingham Tel: 44-118-921-5800 Fax: 44-118-921-5820</p>