PIC32CM MC00 Curiosity Nano Users Guide

Preface

The PIC32CM1216MC00032 Curiosity Nano Evaluation Kit (EV10N93A) is a hardware platform used to evaluate the PIC32CM MC microcontroller (MCU), which is supported by the MPLAB® X Integrated Development Environment (IDE). The evaluation kit provides an easy access to the features of the PIC32CM MC to integrate the device into a custom design. The Curiosity Nano series of evaluation kits includes an on-board Nano Debugger, hence external tools are not required to program the PIC32CM MC device. The PIC32CM MC Curiosity Nano Evaluation Kit is shown in the following figure.

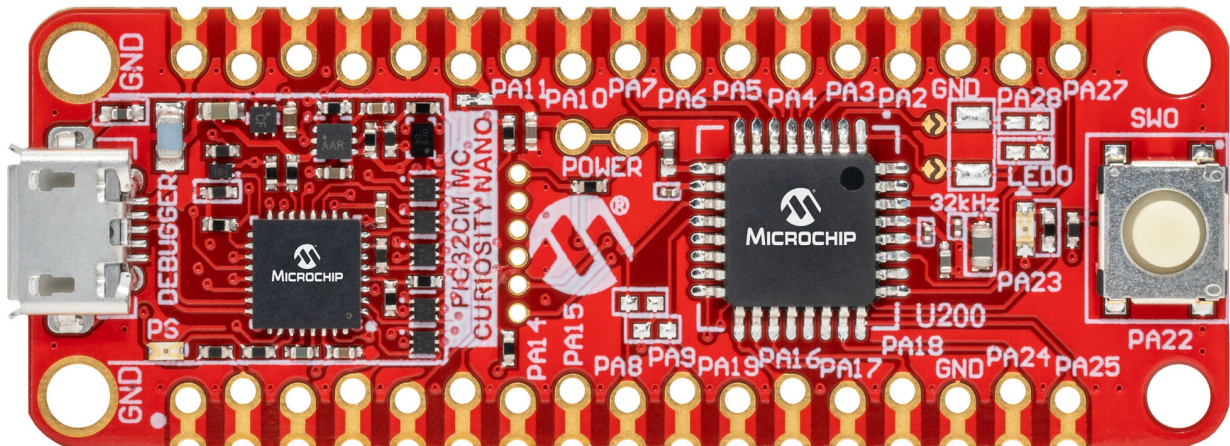

Table of Contents

Preface.....	1
1. Introduction.....	3
1.1. Features.....	3
1.2. Kit Overview.....	3
2. Getting Started.....	4
2.1. Curiosity Nano Quick Start.....	4
3. Curiosity Nano.....	5
3.1. On-Board Debugger.....	5
3.2. Curiosity Nano Standard Pinout.....	6
3.3. Power Supply.....	7
3.4. Disconnecting the On-Board Debugger.....	8
3.5. Current Measurement.....	10
4. Hardware.....	11
4.1. Connectors.....	11
4.2. Peripherals.....	12
4.3. On-Board Debugger Implementation.....	13
5. Hardware Revision History.....	14
5.1. Identifying Product ID and Revision.....	14
6. Schematics.....	15
7. Revision History.....	18
The Microchip Website.....	19
Product Change Notification Service.....	19
Customer Support.....	19
Microchip Devices Code Protection Feature.....	19
Legal Notice.....	20
Trademarks.....	20
Quality Management System.....	21
Worldwide Sales and Service.....	22

1. Introduction

1.1 Features

The following are key features of the PIC32CM MC Curiosity Nano Evaluation Kit:

- PIC32CM1216MC00032 microcontroller
- One yellow user LED
- One mechanical user switch
- On-board debugger
 - Board identification in MPLAB X IDE
 - One green power LED and status LED
 - Programming and debugging
 - Virtual COM port (CDC)
 - One logic analyzer (DGI GPIO)
- USB powered
- Adjustable target voltage
 - MIC5353 LDO regulator controlled by the on-board debugger
 - 2.7-5.1V output voltage
 - 500 mA maximum output current (limited by ambient temperature and output voltage)

1.2 Kit Overview

The PIC32CM MC00 Curiosity Nano Evaluation Kit is a hardware platform to evaluate the PIC32CM MC00.

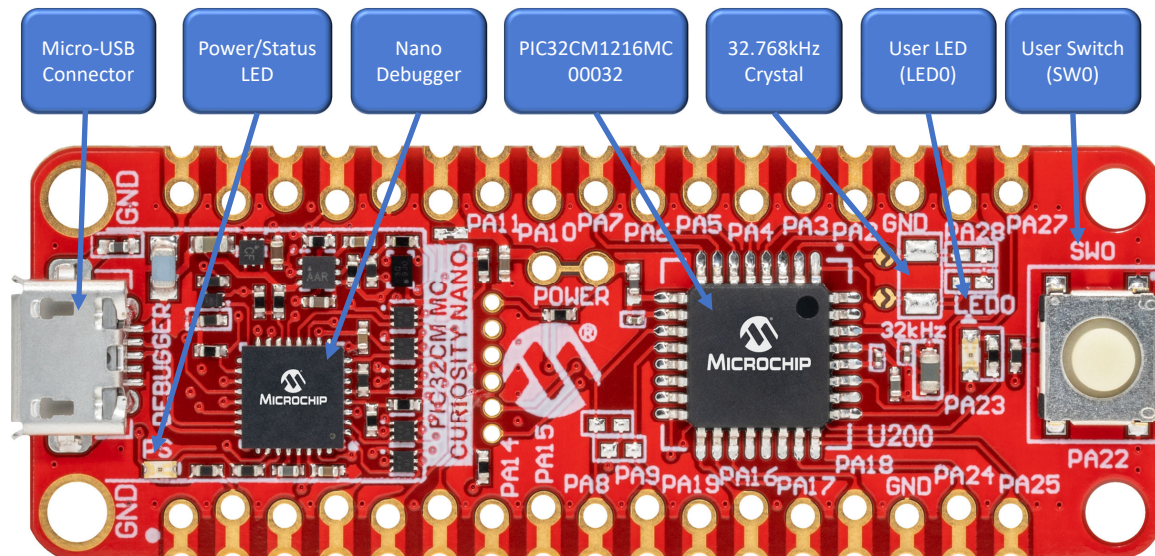

2. Getting Started

2.1 Curiosity Nano Quick Start

Follow these steps to exploring the Curiosity Nano platform:

1. Download MPLAB X IDE.
2. Launch MPLAB X IDE.
3. Connect a USB cable (Standard-A to Micro-B or Micro-AB) between the PC and the debug USB port on the kit.

When the Curiosity Nano kit is connected to the computer for the first time, the operating system will perform a driver software installation. The driver file supports both 32-bit and 64-bit versions of Microsoft® Windows® XP, Windows Vista®, Windows 7, Windows 8, and Windows 10. The drivers for the kit are included with MPLAB X IDE.

Once the Curiosity Nano board is powered, the green status LED will be lit and MPLAB X IDE will auto-detect which Curiosity Nano board is connected. MPLAB X IDE will present relevant information, such as data sheets and kit documentation. The PIC32CM MC00 device is programmed and debugged by the on-board debugger, hence external programmer or debugger tool is not required.

3. Curiosity Nano

Curiosity Nano is an evaluation platform that provides a set of small boards with access to most of the microcontrollers I/Os. The platform consists of a series of low pin-count microcontroller (MCU) boards, which are integrated with MPLAB X IDE to present relevant user guides, application notes, data sheets, and example codes. The platform features a Virtual COM port (CDC) for serial communication to a host PC and a Data Gateway Interface (DGI) GPIO.

3.1 On-Board Debugger

The PIC32CM MC00 Curiosity Nano contains an on-board debugger for programming and debugging. The on-board debugger is a composite USB device of several interfaces: a debugger, a mass storage device, a data gateway, and a Virtual COM port (CDC). Together with MPLAB X IDE, the on-board debugger interface can program and debug the PIC32CM MC00. A Data Gateway Interface (DGI) is available to use with the logic analyzer channels for code instrumentation to visualize program flow. DGI GPIOs can be graphed using the Data Visualizer. The Virtual COM port is connected to a UART on the PIC32CM MC00 and provides an easy way to communicate with the target application through terminal software. The on-board debugger controls one Power and Status LED (marked PS) on the PIC32CM MC00 Curiosity Nano board. The following table shows how the LED is controlled in different operation modes.

Table 3-1. On-Board Debugger LED Control

Operation Mode	Status LED
Boot Loader mode	LED blink at 1 Hz during power up.
Power-up	LED is lit - constant
Normal operation	LED is lit - constant.
Programming	Activity indicator; the LED flashes slowly during programming/debugging.
Fault	The LED flashes fast if a power fault is detected.
Sleep/Off	LED is off. The on-board debugger is either in Sleep mode or powered down. This can occur if the kit is externally powered.

3.1.1 Virtual COM Port

The Virtual COM port is a general purpose USB serial bridge between a host PC and a target device.

3.1.1.1 Overview

The debugger implements a composite USB device that includes a standard Communications Device Class (CDC) interface, which appears on the host as a Virtual COM port. The CDC can be used to stream arbitrary data in both directions between the host and the target. Characters sent from the host will appear in UART form on the CDC TX pin, and UART characters sent into the CDC RX pin will be sent back to the host. On Windows machines, the CDC will enumerate as Curiosity Virtual COM Port and appear in the Ports section of the device manager. The COM port number is usually shown here.



Tip: On older Windows systems, a USB driver is required for CDC. This driver is included in Atmel® Studio and MPLAB X installations. On Linux machines, the CDC will enumerate and appear as `/dev/ttyACM#`. On MAC machines, the CDC will enumerate and appear as `/dev/tty.usbmodem#`. Depending on which terminal program is used, it will appear in the available list of modems as `usbmodem#`.

3.1.1.2 Limitations

All UART features are not implemented in the debugger CDC and the constraints are as follows:

- Baud rate - Must be in the range of 1200 bps to 500 kbps. Values outside this range will be capped to these values, without warning. Baud rate can be changed on-the-fly.
- Character format - Only 8-bit characters are supported
- Parity - It can be odd, even, or none
- Hardware flow control - Not supported
- Stop bits - One or two bits are supported

3.1.1.3 Signaling

During USB enumeration, the host OS will start both communication and data pipes of the CDC interface. At this point, it is possible to set and read back baud rate and other UART parameters of the CDC, but data sending and receiving will not be enabled. When a terminal connects on the host, it must assert the DTR signal. This is a virtual control signal that is implemented on the USB interface, but not in hardware on the debugger. Asserting DTR from the host will indicate to the debugger that a CDC session is active, and it will enable its level shifters (if available), and start the CDC data send and receive mechanisms. Disserting the DTR signal will not disable the level shifters, but it will disable the receiver, hence no further data will be streamed to the host. Data packets that are already queued up for sending to the target will continue to be sent out, but no further data will be accepted.

3.1.1.4 Advanced Use

CDC Override mode in normal operation, the on-board debugger is a true UART bridge between the host and the device. However, under certain use cases, the debugger can override the Basic Operating mode and use the CDC pins for other purposes. Dropping a text file (with extension .txt) into the debugger's mass storage drive can be used to send characters out of the CDC TX pin. The text file must start with the characters: `CMD:SEND_UART=`, the maximum message length is 50 characters. All remaining data in the frame is ignored. The default baud rate used in this mode is 9600 bps, but if the CDC is already active or has been configured, the baud rate last used still applies.

USB-Level Framing Considerations:

Sending data from the host to the CDC can be done byte-wise or in blocks, which will be chunked into 64-byte USB frames. Each such frame will be queued for sending to the CDC TX pin. Sending a small amount of data per frame can be inefficient, particularly at low baud rates, because the debugger buffers frames not bytes. A maximum of 4 x 64-byte frames can be active at any time the debugger will throttle the incoming frames accordingly. Sending full 64-byte frames containing data is the most efficient. When receiving data from the target, the debugger will queue up incoming bytes into 64-byte frames, which are sent to the USB queue for transmission to the host when they are full. Incomplete frames are also pushed to the USB queue at approximately 100 ms intervals, triggered by USB start-of-frame tokens. Up to 8 x 64-byte frames can be active at any time. If the host or software running on it fails to receive data fast enough, an overrun will occur. When this happens the last-filled buffer frame will be recycled instead of being sent to the USB queue, and a full frame of data will be lost. To prevent this occurrence, the user must ensure that the CDC data pipe is being read continuously, or the incoming data rate must be reduced.

3.2 Curiosity Nano Standard Pinout

The twelve edge connections closest to the USB connector on Curiosity Nano kits have a standardized pinout. The program or debug pins have different functions depending on the target programming interface as shown in the following table and figure.

Table 3-2. Curiosity Nano Standard Pinout

Debugger Signal	Target	Description
NC	-	No Connect
ID	-	ID line for extensions.
CDC TX	UART RX	USB CDC TX line.
CDC RX	UART TX	USB CDC RX line.
DBG1	SWCLK	Debug clock line
DBG2	GPIO	DGI GPIO

.....continued

Debugger Signal	Target	Description
VTG	-	Target voltage
GND	-	Common ground.
DBG0	SWDATA	Debug data line.
DBG3	nRESET	Reset line
VOFF	-	Voltage Off input.
VBUS	-	VBUS voltage for external use.

Figure 3-1. Curiosity Nano Standard Pinout

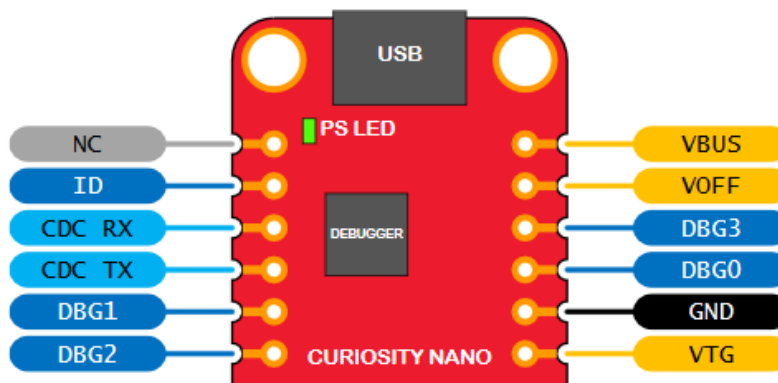

3.3 Power Supply

The kit is powered through the USB port and contains two regulators for generating 3.3V for the debugger and an adjustable regulator for the target. The voltage from the USB connector can vary between 4.4V to 5.25V (according to the USB specification) and will limit the maximum voltage to the target. The following figure shows the entire power supply system on the PIC32CM MC00 Curiosity Nano.

Figure 3-2. Power Supply Block Diagram

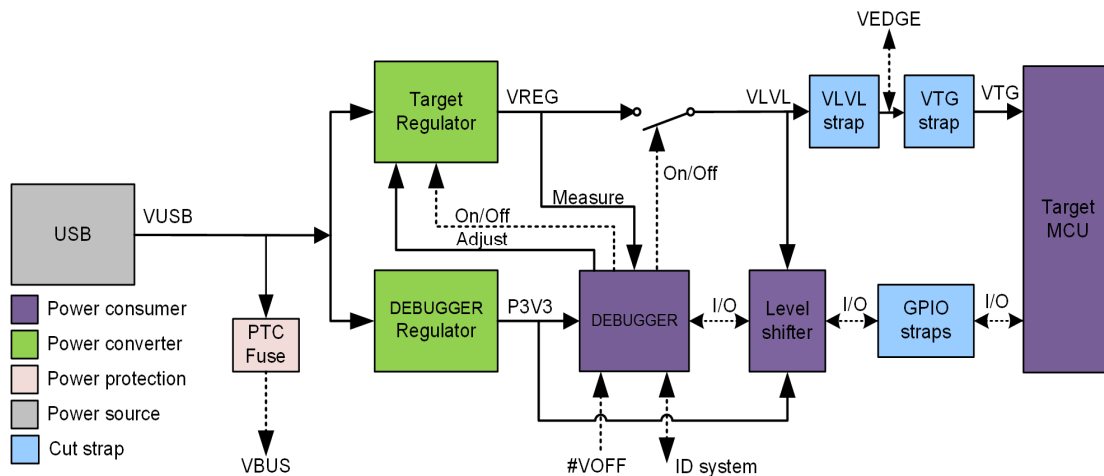

3.3.1 Target Regulator

The target voltage regulator is a MIC5353 variable output LDO. The on-board debugger can adjust the voltage output that is supplied to the kit target section by manipulating the MIC5353's feedback voltage. The hardware implementation is limited to an approximate voltage range from 2.7V to 5.1V. Additional output voltage limits are configured in the debugger firmware to ensure that the output voltage never exceeds the hardware limits of the PIC32CM MC00 microcontroller. The voltage limits configured in the on-board debugger for the PIC32CM MC00 Curiosity Nano are 2.7 – 5.6 V. The target voltage is set to 3.3V in production and can be changed through MPLAB X IDE. Any change to the target voltage done in MPLAB X IDE is persistent, even through a power toggle. The MIC5353 supports a maximum current load of 500 mA. It is an LDO regulator in a small package, placed on a small PCB, and the thermal shutdown condition can be reached at lower loads than 500 mA. The maximum current load depends on the input voltage, set output voltage, and the ambient temperature. The following figure shows the safe operation area for the regulator, with an input voltage of 5.1V and an ambient temperature of 23°C.

Figure 3-3. Target Regulator Safe Operation Area

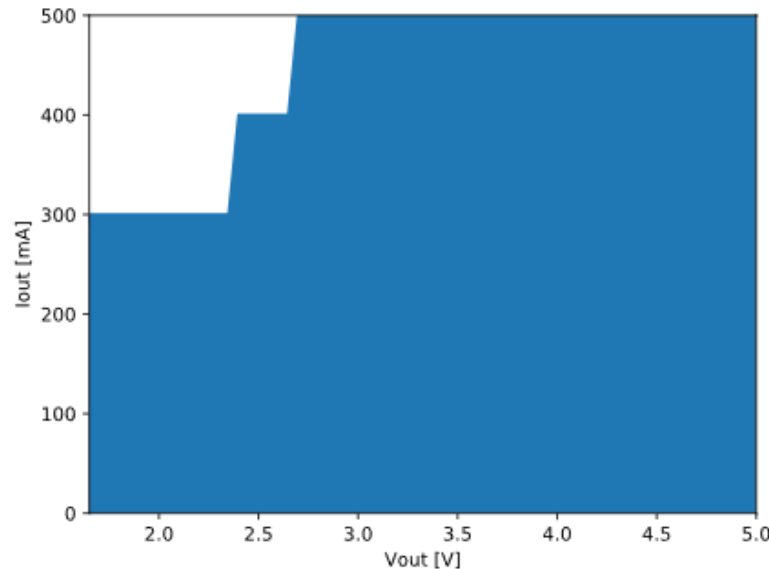

3.3.2 External Supply

The PIC32CM MC00 Curiosity Nano can be powered by an external voltage instead of the on-board target regulator. When the Voltage Off (VOFF) pin is shorted to ground (GND) the on-board debugger firmware disables the target regulator and it is safe to apply an external voltage to the VTG pin.



1. Applying an external voltage to the VTG pin without shorting the VOFF pin to GND may cause permanent damage to the kit.
2. Absolute maximum external voltage is 5.5V for the level shifters on board. Applying a higher voltage may cause permanent damage to the kit.

Programming, debugging, and data streaming is still possible while using external power. The debugger and signal level shifters will be powered from the USB cable. Both regulators, the debugger, and the level shifters are powered down when the USB cable is removed.

3.4 Disconnecting the On-Board Debugger

The following block diagram shows all connections between the debugger and the PIC32CM MC00 microcontroller. The rounded boxes represent connections to the board edge on the PIC32CM MC00 Curiosity Nano. The signal names are shown in the following figure and printed in silkscreen on the bottom of the board.

Figure 3-4. On-Board Debugger Connections

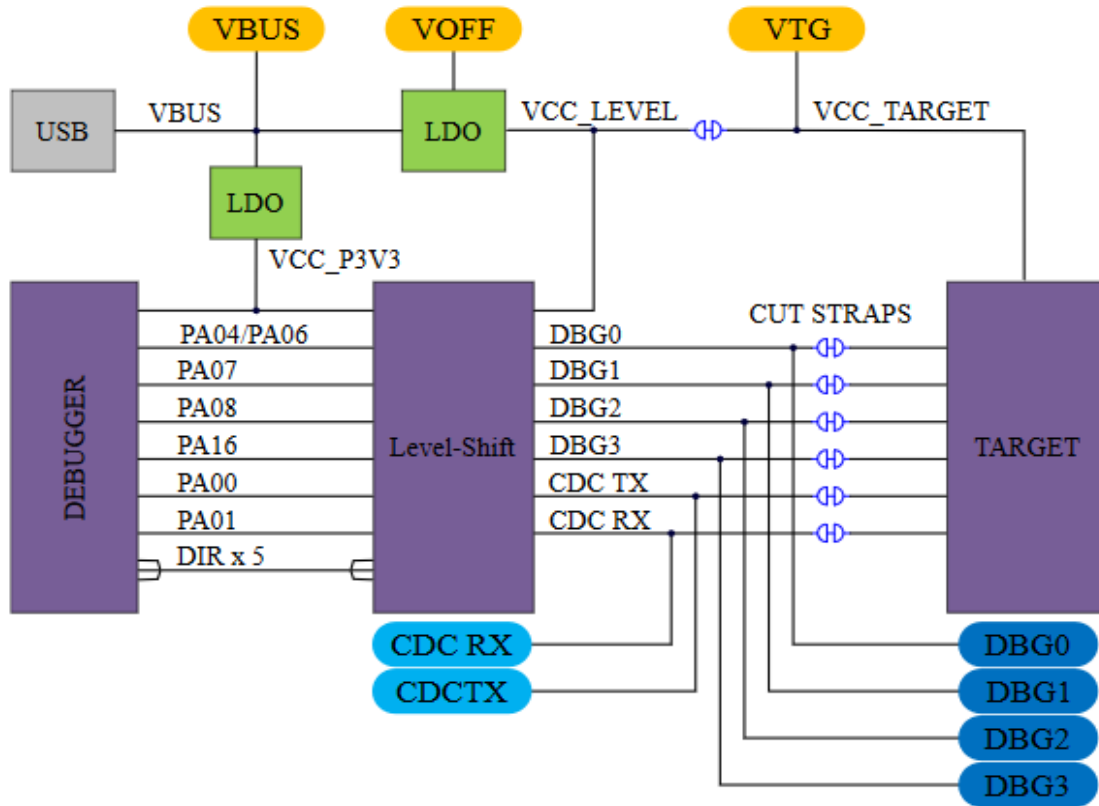

By cutting the GPIO straps with a sharp tool, all I/Os connected between the debugger and the PIC32CM MC00 are disconnected. To disconnect the target regulator, cut the VTG strap shown in the following figure.



Tip:

1. Cutting the connections to the debugger will disable programming, debugging, data streaming, and the target power supply. The signals will also be disconnected from the board edge next to the on-board debugger section.
2. Solder in 0Ω resistors across the footprints or short-circuit them with tin solder to reconnect any cut signals.

Figure 3-5. Location of GPIO and VTG Straps

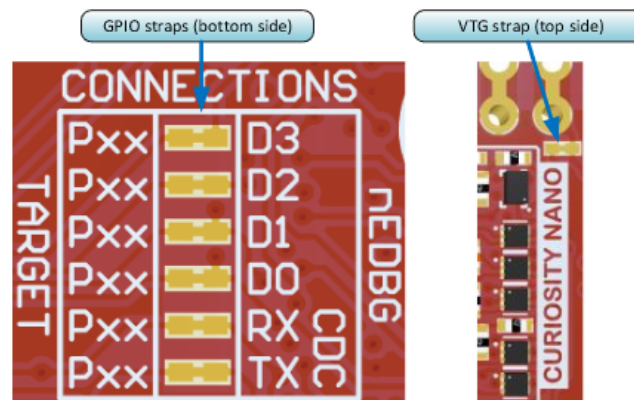

3.5 Current Measurement

The power to the PIC32CM MC00 is connected from the on-board power supply to the target voltage supply (VTG) with a cut strap as shown in [Disconnecting the On-Board Debugger](#). To measure the power consumption of the PIC32CM MC00 and other peripherals connected to the board, cut the strap and connect an ammeter over the strap. The ammeter can be connected between the target VTG pad edge connector and an external power supply for the easy measurement. Alternatively, an external power supply can be used as described in [External Supply](#).

Info: The on-board level shifters will draw a small amount of current even when they are not in use. A maximum of 10 μA can be drawn from the VTG net and an additional 2 μA can be drawn from each I/O pin connected to a level shifter for a total of 20 μA . Disconnect the on-board debugger and level shifters as described in [Disconnecting the On-Board Debugger](#) to prevent any leakage.

4. Hardware

4.1 Connectors

4.1.1 PIC32CM MC00 Curiosity Nano Pinout

All of the PIC32CM MC00 I/O pins are accessible at the edge connectors on the PIC32CM MC00 Curiosity Nano except the button (PA22) and LED (PA23). The following figure shows the kit pinout. RA30 and RA31 are only available at the edge connector in the debugger section as long as the cut straps on the bottom are not cut.

Figure 4-1. PIC32CM MC00 Curiosity Nano Pinout

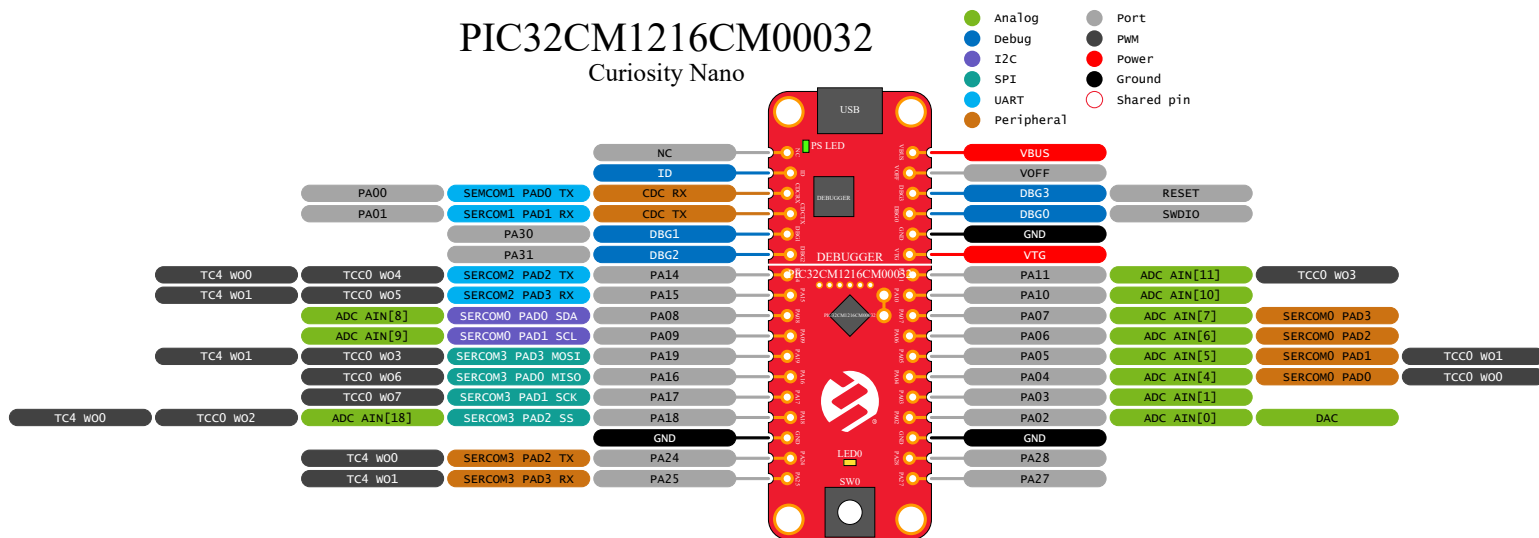

Note: All pin functions are not listed in the diagram and additional functions are available on these pins. For a list of additional functions, refer to the latest data sheet available at www.microchip.com.

4.1.2 PIC32CM MC00 Curiosity Nano Base Quick Reference

The PIC32CM MC00 Curiosity Nano is compatible with the Curiosity Nano Base for click boards™ (AC164162). The following figure shows a simplified reference to enable quicker development. For additional information, visit www.microchip.com/developmenttools/ProductDetails/AC164162.

Figure 4-2. PIC32CM MC00 Curiosity Nano Base

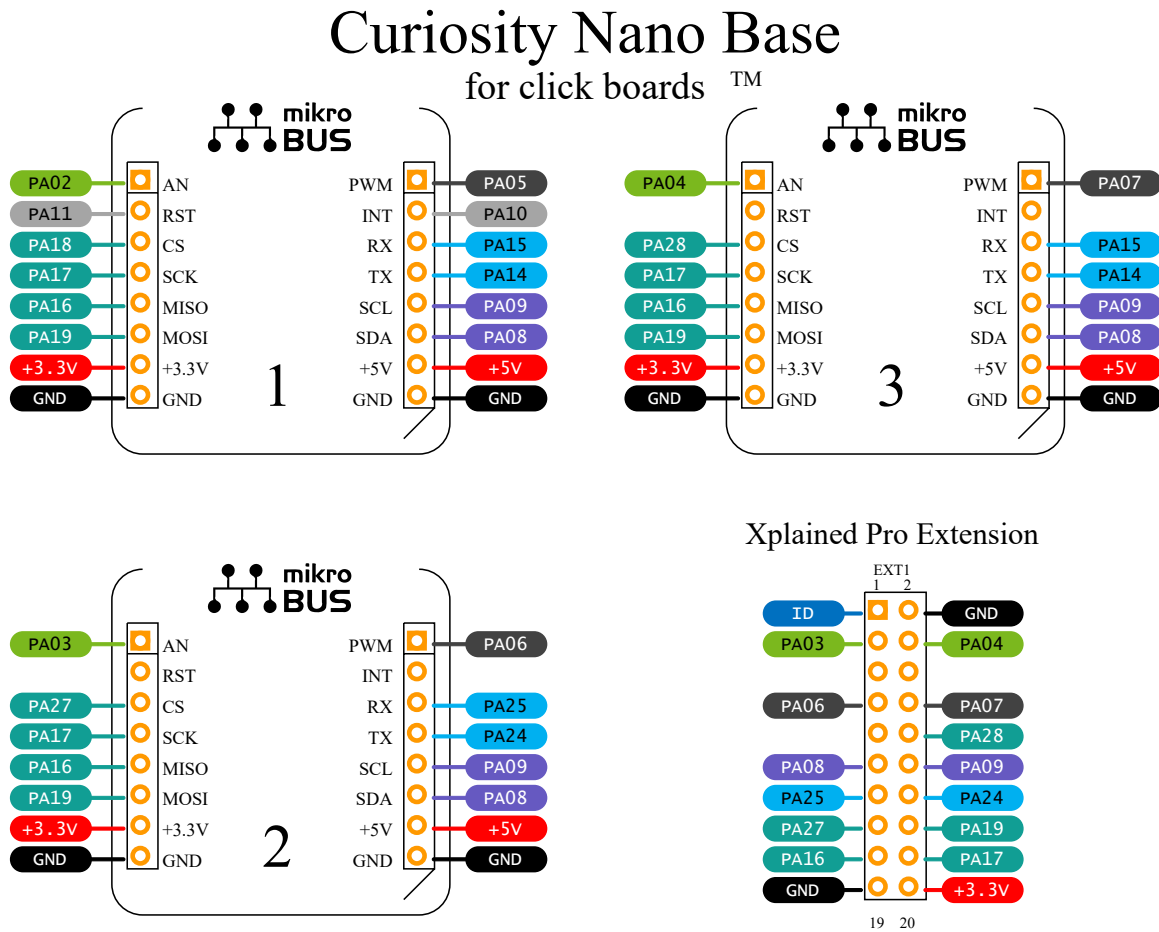

4.2 Peripherals

4.2.1 LED

One yellow user LED is available on the PIC32CM MC00 Curiosity Nano kit which can be controlled with either GPIO or PWM. The LED can be activated by driving the connected I/O line to GND.

Table 4-1. LED Connection

PIC32CM MC00	Function	Shared Functionality
PA23	Yellow LED0	None

4.2.2 Mechanical Switch

The PIC32CM MC00 Curiosity Nano has one mechanical switch. This is a generic user configurable switch and when the switch is pressed, it will drive the I/O line to ground (GND).



Remember: Pull-up resistor is not connected to the generic user switch. To use the switch, users need to enable the internal pull-up in the PIC32CM MC00.

Table 4-2. Mechanical Switch

PIC32CM MC00	Function	Shared Functionality
PA1522	User Switch SW0	DBG2 (for data visualizer)

4.2.3 Crystal

The PIC32CM MC00 Curiosity Nano board has the option for a 32.768 kHz crystal that is mounted but not by default.

By default, the crystal is not connected to the PIC32CM MC00 as the GPIO's are routed out to the edge connector. To use the crystal, some hardware modifications are required. The two I/O lines routed to the edge connector must be disconnected to reduce the chance of contention to the crystal, and to remove excessive capacitance on the lines.

Table 4-3. Crystal Connections

PIC32CM MC00 pin	Function	Shared Functionality
PA00	XIN32	DBG TX
PA01	XOUT32	DBG RX

4.3 On-Board Debugger Implementation

The PIC32CM MC00 Curiosity Nano features an on-board debugger that can be used to program and debug the PIC32CM MC00 using a Serial wire debug (SWD). The on-board debugger also includes a Virtual COM port interface over the UART and DGI GPIO. MPLAB X IDE can be used as a front-end for the on-board debugger for programming and debugging. A Data Visualizer can be used as a front-end for the CDC and DGI GPIO.

4.3.1 On-Board Debugger Connections

The following table shows the connections between the target and the debugger section. All connections between the target and the debugger are tri-stated as long as the debugger is not actively using the interface, and therefore little contamination of the signals and the pins can be configured to the application requirements. For additional information on using the capabilities of the on-board debugger, refer to [Curiosity Nano](#).

Table 4-4. Connections Between the Target and the Debugger

PIC32CM MC00 pin	Debugger pin	Function	Shared Functionality
PA01	CDC TX	UART TX (PIC32CM MC00 RX line)	Edge Connector
PA00	CDC RX	UART RX (PIC32CM MC00 TX line)	Edge Connector
PA31	DBG0	SWDATA	Edge Connector
PA30	DBG1	SWCLK	Edge Connector
PB30	DBG2	SW0	Edge Connector
nRESET	DBG3	nRESET	Edge Connector
VCC_TARGET	VCC_LEVEL	2.7-5.5v supply voltage	Edge Connector
GND	GND	Common ground	Edge Connector

4.3.2 I²C Pull Ups

The PIC32 CM MC00 has a spot for two I²C pulls which are not mounted by default and can be mounted by populating the SMD 0402 resistor into R203 and R204.

5. Hardware Revision History

This user guide provides the latest available revision of the kit. This chapter contains information about known issues, a revision history of older revisions, and how older revisions differ from the latest revision.

5.1 Identifying Product ID and Revision

The revision and product identifier of Curiosity Nano boards can be found in two ways; either through MPLAB X IDE or by looking at the sticker on the bottom side of the PCB. By connecting a Curiosity Nano board to a computer with MPLAB X IDE running, an information window will pop up. The first six digits of the serial number, which is listed under kit details, contain the product identifier and revision. The same information can be found on the sticker on the bottom side of the PCB. Most kits will print the identifier and revision in plain text as A09-nnnn\rr, where 'nnnn' is the identifier and 'rr' is the revision. Boards with limited space have a sticker with only a QR-code, which contains a serial number string. The serial number string has the following format:

"nnnnrrssssssssss"

n = product identifier

r = revision

s = serial number

6. Schematics

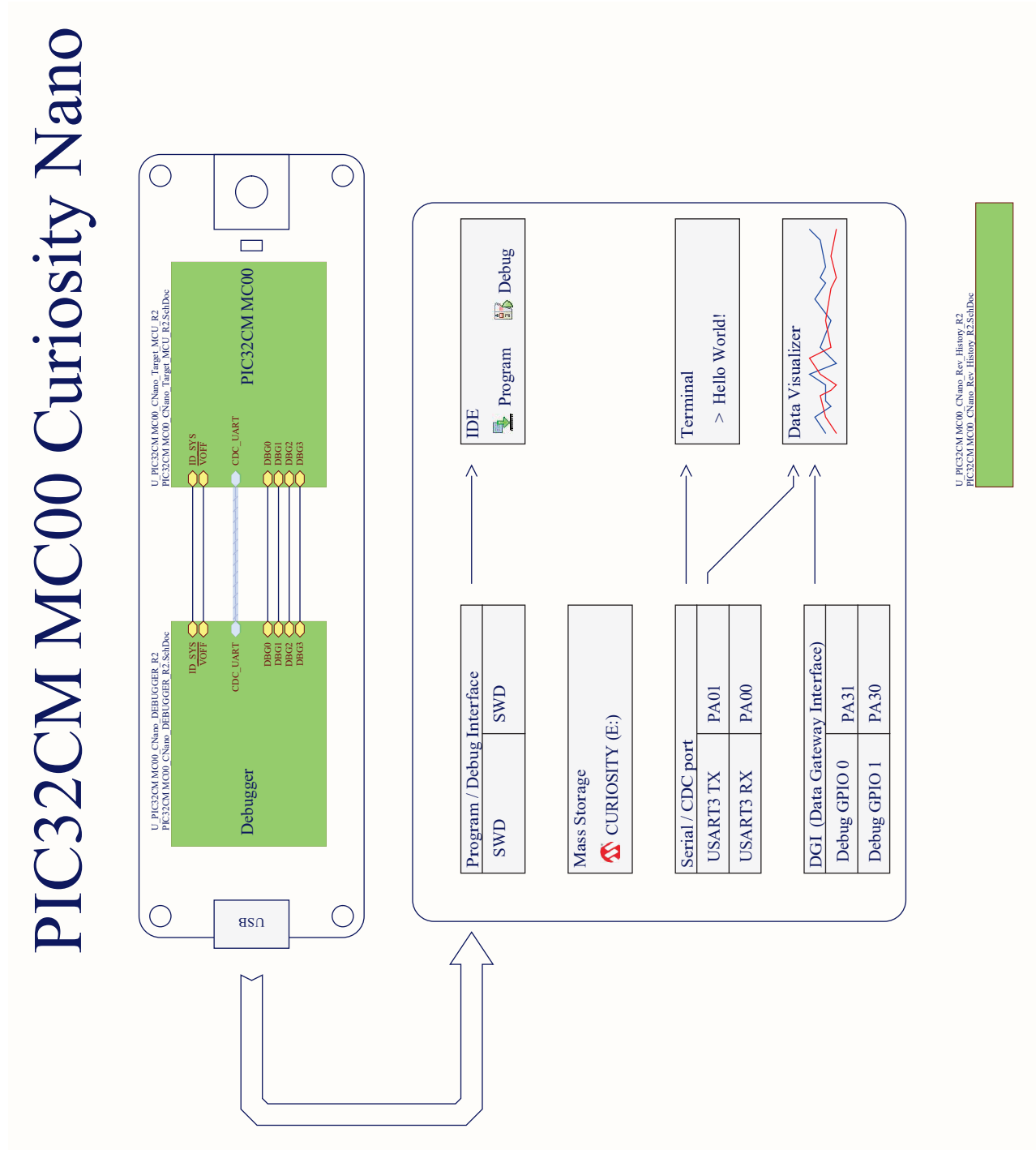

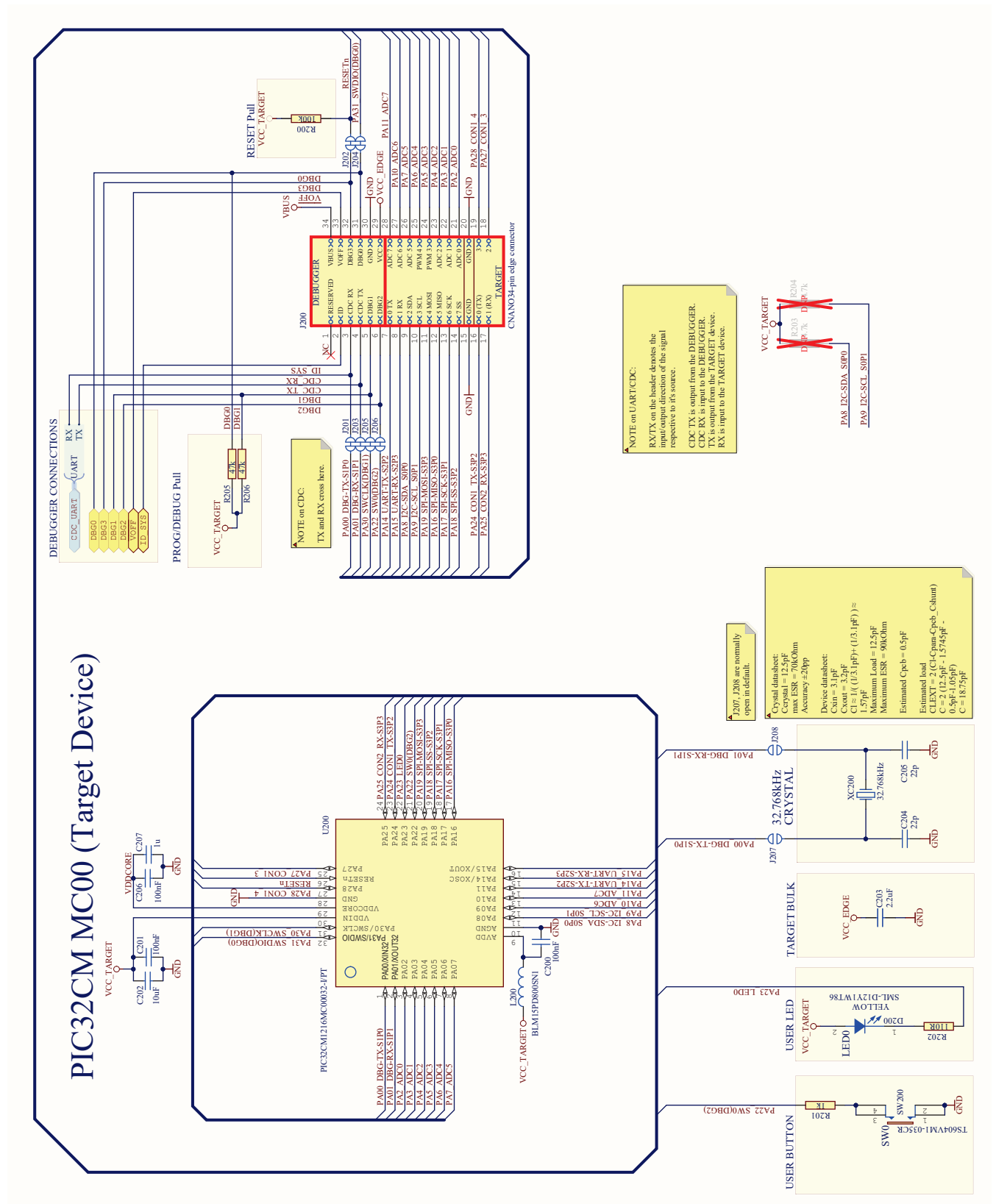

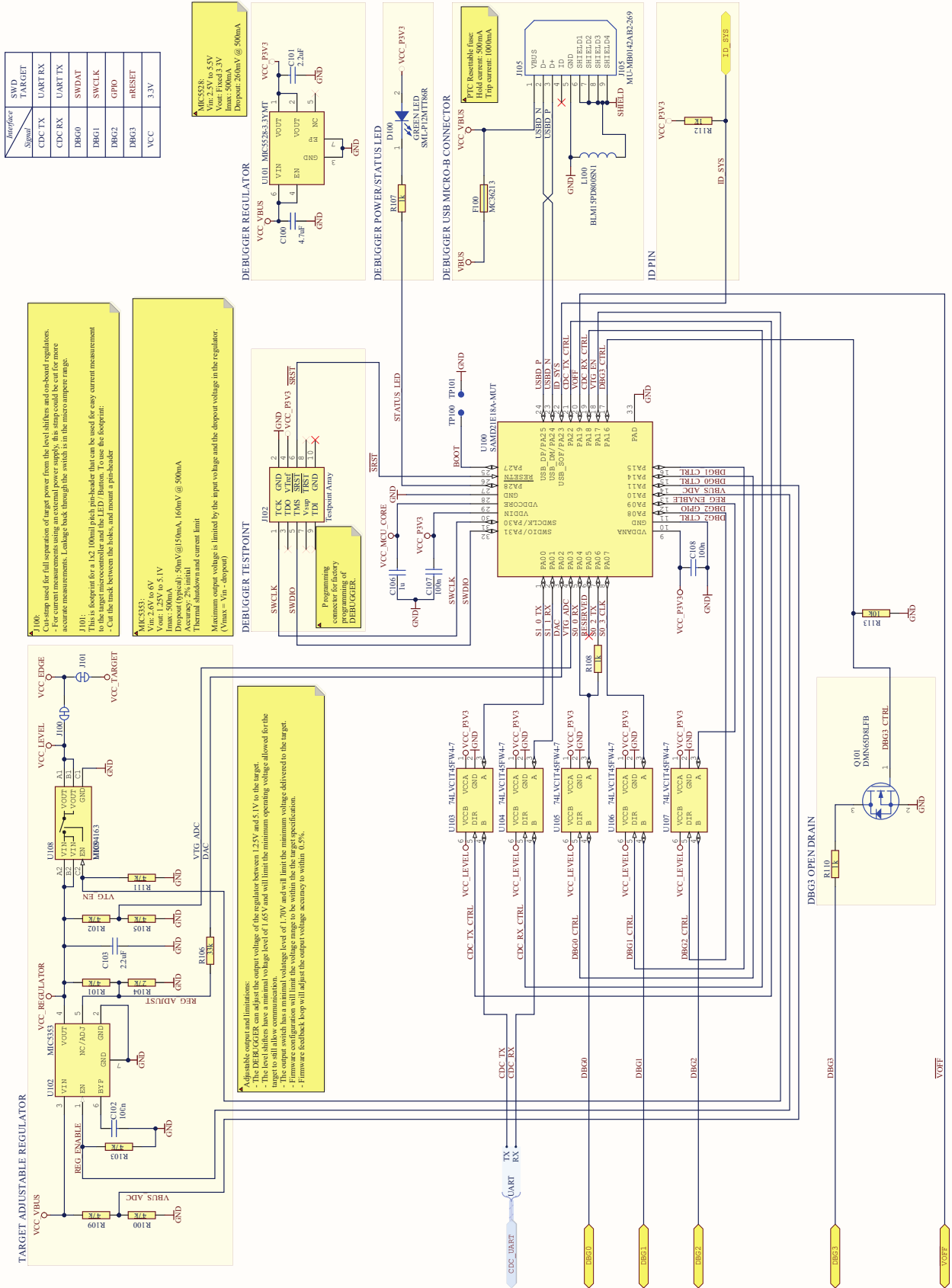

7. Revision History

Rev. A (12/2020)

This is the initial released version of this document.

The Microchip Website

Microchip provides online support via our website at www.microchip.com/. This website is used to make files and information easily available to customers. Some of the content available includes:

- **Product Support** – Data sheets and errata, application notes and sample programs, design resources, user's guides and hardware support documents, latest software releases and archived software
- **General Technical Support** – Frequently Asked Questions (FAQs), technical support requests, online discussion groups, Microchip design partner program member listing
- **Business of Microchip** – Product selector and ordering guides, latest Microchip press releases, listing of seminars and events, listings of Microchip sales offices, distributors and factory representatives

Product Change Notification Service

Microchip's product change notification service helps keep customers current on Microchip products. Subscribers will receive email notification whenever there are changes, updates, revisions or errata related to a specified product family or development tool of interest.

To register, go to www.microchip.com/pcn and follow the registration instructions.

Customer Support

Users of Microchip products can receive assistance through several channels:

- Distributor or Representative
- Local Sales Office
- Embedded Solutions Engineer (ESE)
- Technical Support

Customers should contact their distributor, representative or ESE for support. Local sales offices are also available to help customers. A listing of sales offices and locations is included in this document.

Technical support is available through the website at: www.microchip.com/support

Microchip Devices Code Protection Feature

Note the following details of the code protection feature on Microchip devices:

- Microchip products meet the specifications contained in their particular Microchip Data Sheet.
- Microchip believes that its family of products is secure when used in the intended manner and under normal conditions.
- There are dishonest and possibly illegal methods being used in attempts to breach the code protection features of the Microchip devices. We believe that these methods require using the Microchip products in a manner outside the operating specifications contained in Microchip's Data Sheets. Attempts to breach these code protection features, most likely, cannot be accomplished without violating Microchip's intellectual property rights.
- Microchip is willing to work with any customer who is concerned about the integrity of its code.
- Neither Microchip nor any other semiconductor manufacturer can guarantee the security of its code. Code protection does not mean that we are guaranteeing the product is "unbreakable." Code protection is constantly evolving. We at Microchip are committed to continuously improving the code protection features of our products. Attempts to break Microchip's code protection feature may be a violation of the Digital Millennium Copyright Act. If such acts allow unauthorized access to your software or other copyrighted work, you may have a right to sue for relief under that Act.

Legal Notice

Information contained in this publication is provided for the sole purpose of designing with and using Microchip products. Information regarding device applications and the like is provided only for your convenience and may be superseded by updates. It is your responsibility to ensure that your application meets with your specifications.

THIS INFORMATION IS PROVIDED BY MICROCHIP "AS IS". MICROCHIP MAKES NO REPRESENTATIONS OR WARRANTIES OF ANY KIND WHETHER EXPRESS OR IMPLIED, WRITTEN OR ORAL, STATUTORY OR OTHERWISE, RELATED TO THE INFORMATION INCLUDING BUT NOT LIMITED TO ANY IMPLIED WARRANTIES OF NON-INFRINGEMENT, MERCHANTABILITY, AND FITNESS FOR A PARTICULAR PURPOSE OR WARRANTIES RELATED TO ITS CONDITION, QUALITY, OR PERFORMANCE.

IN NO EVENT WILL MICROCHIP BE LIABLE FOR ANY INDIRECT, SPECIAL, PUNITIVE, INCIDENTAL OR CONSEQUENTIAL LOSS, DAMAGE, COST OR EXPENSE OF ANY KIND WHATSOEVER RELATED TO THE INFORMATION OR ITS USE, HOWEVER CAUSED, EVEN IF MICROCHIP HAS BEEN ADVISED OF THE POSSIBILITY OR THE DAMAGES ARE FORESEEABLE. TO THE FULLEST EXTENT ALLOWED BY LAW, MICROCHIP'S TOTAL LIABILITY ON ALL CLAIMS IN ANY WAY RELATED TO THE INFORMATION OR ITS USE WILL NOT EXCEED THE AMOUNT OF FEES, IF ANY, THAT YOU HAVE PAID DIRECTLY TO MICROCHIP FOR THE INFORMATION. Use of Microchip devices in life support and/or safety applications is entirely at the buyer's risk, and the buyer agrees to defend, indemnify and hold harmless Microchip from any and all damages, claims, suits, or expenses resulting from such use. No licenses are conveyed, implicitly or otherwise, under any Microchip intellectual property rights unless otherwise stated.

Trademarks

The Microchip name and logo, the Microchip logo, Adaptec, AnyRate, AVR, AVR logo, AVR Freaks, BesTime, BitCloud, chipKIT, chipKIT logo, CryptoMemory, CryptoRF, dsPIC, FlashFlex, flexPWR, HELDO, IGLOO, JukeBlox, KeeLoq, Klear, LANCheck, LinkMD, maXStylus, maXTouch, MediaLB, megaAVR, Microsemi, Microsemi logo, MOST, MOST logo, MPLAB, OptoLyzer, PackeTime, PIC, picoPower, PICSTART, PIC32 logo, PolarFire, Prochip Designer, QTouch, SAM-BA, SenGenuity, SpyNIC, SST, SST Logo, SuperFlash, Symmetricom, SyncServer, Tachyon, TempTrackr, TimeSource, tinyAVR, UNI/O, Vectron, and XMEGA are registered trademarks of Microchip Technology Incorporated in the U.S.A. and other countries.

APT, ClockWorks, The Embedded Control Solutions Company, EtherSynch, FlashTec, Hyper Speed Control, HyperLight Load, IntelliMOS, Libero, motorBench, mTouch, Powermite 3, Precision Edge, ProASIC, ProASIC Plus, ProASIC Plus logo, Quiet-Wire, SmartFusion, SyncWorld, Temux, TimeCesium, TimeHub, TimePictra, TimeProvider, Vite, WinPath, and ZL are registered trademarks of Microchip Technology Incorporated in the U.S.A.

Adjacent Key Suppression, AKS, Analog-for-the-Digital Age, Any Capacitor, AnyIn, AnyOut, BlueSky, BodyCom, CodeGuard, CryptoAuthentication, CryptoAutomotive, CryptoCompanion, CryptoController, dsPICDEM, dsPICDEM.net, Dynamic Average Matching, DAM, ECAN, EtherGREEN, In-Circuit Serial Programming, ICSP, INICnet, Inter-Chip Connectivity, JitterBlocker, KlearNet, KlearNet logo, memBrain, Mindi, MiWi, MPASM, MPF, MPLAB Certified logo, MPLIB, MPLINK, MultiTRAK, NetDetach, Omniscient Code Generation, PICDEM, PICDEM.net, PICkit, PICtail, PowerSmart, PureSilicon, QMatrix, REAL ICE, Ripple Blocker, SAM-ICE, Serial Quad I/O, SMART-I.S., SQI, SuperSwitcher, SuperSwitcher II, Total Endurance, TSHARC, USBCheck, VariSense, ViewSpan, WiperLock, Wireless DNA, and ZENA are trademarks of Microchip Technology Incorporated in the U.S.A. and other countries.

SQTP is a service mark of Microchip Technology Incorporated in the U.S.A.

The Adaptec logo, Frequency on Demand, Silicon Storage Technology, and Symmcom are registered trademarks of Microchip Technology Inc. in other countries.

GestIC is a registered trademark of Microchip Technology Germany II GmbH & Co. KG, a subsidiary of Microchip Technology Inc., in other countries.

All other trademarks mentioned herein are property of their respective companies.

© 2020, Microchip Technology Incorporated, Printed in the U.S.A., All Rights Reserved.

ISBN: 978-1-5224-7336-7

Quality Management System

For information regarding Microchip's Quality Management Systems, please visit www.microchip.com/quality.

Worldwide Sales and Service

AMERICAS	ASIA/PACIFIC	ASIA/PACIFIC	EUROPE
<p>Corporate Office 2355 West Chandler Blvd. Chandler, AZ 85224-6199 Tel: 480-792-7200 Tel: 480-792-7277 Technical Support: www.microchip.com/support Web Address: www.microchip.com</p> <p>Atlanta Duluth, GA Tel: 678-957-9614 Fax: 678-957-1455</p> <p>Austin, TX Tel: 512-257-3370</p> <p>Boston Westborough, MA Tel: 774-760-0087 Fax: 774-760-0088</p> <p>Chicago Itasca, IL Tel: 630-285-0071 Fax: 630-285-0075</p> <p>Dallas Addison, TX Tel: 972-818-7423 Fax: 972-818-2924</p> <p>Detroit Novi, MI Tel: 248-848-4000</p> <p>Houston, TX Tel: 281-894-5983</p> <p>Indianapolis Noblesville, IN Tel: 317-773-8323 Fax: 317-773-5453 Tel: 317-536-2380</p> <p>Los Angeles Mission Viejo, CA Tel: 949-462-9523 Fax: 949-462-9608 Tel: 951-273-7800</p> <p>Raleigh, NC Tel: 919-844-7510</p> <p>New York, NY Tel: 631-435-6000</p> <p>San Jose, CA Tel: 408-735-9110 Tel: 408-436-4270</p> <p>Canada - Toronto Tel: 905-695-1980 Fax: 905-695-2078</p>	<p>Australia - Sydney Tel: 61-2-9868-6733</p> <p>China - Beijing Tel: 86-10-8569-7000</p> <p>China - Chengdu Tel: 86-28-8665-5511</p> <p>China - Chongqing Tel: 86-23-8980-9588</p> <p>China - Dongguan Tel: 86-769-8702-9880</p> <p>China - Guangzhou Tel: 86-20-8755-8029</p> <p>China - Hangzhou Tel: 86-571-8792-8115</p> <p>China - Hong Kong SAR Tel: 852-2943-5100</p> <p>China - Nanjing Tel: 86-25-8473-2460</p> <p>China - Qingdao Tel: 86-532-8502-7355</p> <p>China - Shanghai Tel: 86-21-3326-8000</p> <p>China - Shenyang Tel: 86-24-2334-2829</p> <p>China - Shenzhen Tel: 86-755-8864-2200</p> <p>China - Suzhou Tel: 86-186-6233-1526</p> <p>China - Wuhan Tel: 86-27-5980-5300</p> <p>China - Xian Tel: 86-29-8833-7252</p> <p>China - Xiamen Tel: 86-592-2388138</p> <p>China - Zhuhai Tel: 86-756-3210040</p>	<p>India - Bangalore Tel: 91-80-3090-4444</p> <p>India - New Delhi Tel: 91-11-4160-8631</p> <p>India - Pune Tel: 91-20-4121-0141</p> <p>Japan - Osaka Tel: 81-6-6152-7160</p> <p>Japan - Tokyo Tel: 81-3-6880-3770</p> <p>Korea - Daegu Tel: 82-53-744-4301</p> <p>Korea - Seoul Tel: 82-2-554-7200</p> <p>Malaysia - Kuala Lumpur Tel: 60-3-7651-7906</p> <p>Malaysia - Penang Tel: 60-4-227-8870</p> <p>Philippines - Manila Tel: 63-2-634-9065</p> <p>Singapore Tel: 65-6334-8870</p> <p>Taiwan - Hsin Chu Tel: 886-3-577-8366</p> <p>Taiwan - Kaohsiung Tel: 886-7-213-7830</p> <p>Taiwan - Taipei Tel: 886-2-2508-8600</p> <p>Thailand - Bangkok Tel: 66-2-694-1351</p> <p>Vietnam - Ho Chi Minh Tel: 84-28-5448-2100</p>	<p>Austria - Wels Tel: 43-7242-2244-39 Fax: 43-7242-2244-393</p> <p>Denmark - Copenhagen Tel: 45-4485-5910 Fax: 45-4485-2829</p> <p>Finland - Espoo Tel: 358-9-4520-820</p> <p>France - Paris Tel: 33-1-69-53-63-20 Fax: 33-1-69-30-90-79</p> <p>Germany - Garching Tel: 49-8931-9700</p> <p>Germany - Haan Tel: 49-2129-3766400</p> <p>Germany - Heilbronn Tel: 49-7131-72400</p> <p>Germany - Karlsruhe Tel: 49-721-625370</p> <p>Germany - Munich Tel: 49-89-627-144-0 Fax: 49-89-627-144-44</p> <p>Germany - Rosenheim Tel: 49-8031-354-560</p> <p>Israel - Ra'anana Tel: 972-9-744-7705</p> <p>Italy - Milan Tel: 39-0331-742611 Fax: 39-0331-466781</p> <p>Italy - Padova Tel: 39-049-7625286</p> <p>Netherlands - Drunen Tel: 31-416-690399 Fax: 31-416-690340</p> <p>Norway - Trondheim Tel: 47-72884388</p> <p>Poland - Warsaw Tel: 48-22-3325737</p> <p>Romania - Bucharest Tel: 40-21-407-87-50</p> <p>Spain - Madrid Tel: 34-91-708-08-90 Fax: 34-91-708-08-91</p> <p>Sweden - Gothenberg Tel: 46-31-704-60-40</p> <p>Sweden - Stockholm Tel: 46-8-5090-4654</p> <p>UK - Wokingham Tel: 44-118-921-5800 Fax: 44-118-921-5820</p>