

Antenna

YC0001AA Datasheet

Antenna Services

Version: 2.2

Date: 2021-01-27

Status: Released



Our aim is to provide customers with timely and comprehensive service. For any assistance, please contact our company headquarters:

Quectel Wireless Solutions Co., Ltd.

Building 5, Shanghai Business Park Phase III (Area B), No.1016 Tianlin Road, Minhang District, Shanghai 200233, China

Tel: +86 21 5108 6236

Email: info@quectel.com

Or our local office. For more information, please visit:

<http://www.quectel.com/support/sales.htm>.

For technical support, or to report documentation errors, please visit:

<http://www.quectel.com/support/technical.htm>

Or email to support@quectel.com.

General Notes

Quectel offers the information as a service to its customers. The information provided is based upon customers' requirements. Quectel makes every effort to ensure the quality of the information it makes available. Quectel does not make any warranty as to the information contained herein, and does not accept any liability for any injury, loss or damage of any kind incurred by use of or reliance upon the information. All information supplied herein is subject to change without prior notice.

Disclaimer

While Quectel has made efforts to ensure that the functions and features under development are free from errors, it is possible that these functions and features could contain errors, inaccuracies and omissions. Unless otherwise provided by valid agreement, Quectel makes no warranties of any kind, implied or express, with respect to the use of features and functions under development. To the maximum extent permitted by law, Quectel excludes all liability for any loss or damage suffered in connection with the use of the functions and features under development, regardless of whether such loss or damage may have been foreseeable.

Duty of Confidentiality

The Receiving Party shall keep confidential all documentation and information provided by Quectel, except when the specific permission has been granted by Quectel. The Receiving Party shall not access or use Quectel's documentation and information for any purpose except as expressly provided herein. Furthermore, the Receiving Party shall not disclose any of the Quectel's documentation and information to any third party without the prior written consent by Quectel. For any noncompliance to the above requirements, unauthorized use, or other illegal or malicious use of the documentation and information, Quectel will reserve the right to take legal action.

Copyright

The information contained here is proprietary technical information of Quectel. Transmitting, reproducing, disseminating and editing this document as well as using the content without permission are forbidden. Offenders will be held liable for payment of damages. All rights are reserved in the event of a patent grant or registration of a utility model or design.

Copyright © Quectel Wireless Solutions Co., Ltd. 2021. All rights reserved.

About the Document

Revision History

Version	Date	Author	Note
1.0	2020-05-28	Kenny YIN	Initial
2.0	2020-06-22	Kenny YIN	Updated the specifications.
2.1	2020-12-11	Kenny YIN	Updated the antenna image in Chapter 2.
2.2	2021-01-27	Kenny YIN	Added return loss data, pattern laboratory pictures, package parameters.

Contents

About the Document.....	3
Contents.....	4
1 Product Description.....	5
2 Product Features	5
3 Product Specifications	6
4 Overall Performance.....	7
4.1. Test Environment	7
4.2 VSWR.....	8
4.3 Return Loss.....	8
4.4 Efficiency.....	9
4.5 Gain.....	10
4.6 Radiation Patterns.....	11
5 Schematic Symbol and Pin Definition	13
6 Transmission Line	14
7 Matching Circuit.....	15
8 Host PCB Requirement	17
8.1. Host PCB Size	18
9 Soldering Temperature.....	20
10 Reflow Profile	20
11 Package.....	21
12 Product Size	22

1 Product Description

The antenna is designed for superior performance, and can be widely used for wireless applications.

We provide comprehensive antenna design support such as simulation, testing and manufacturing for custom antenna solutions to meet your specific application needs.

2 Product Features

- Cellular LTE
- High efficiency
- Excellent performance



3 Product Specifications

Passive Electrical Specifications

Frequency Range	698–960 MHz, 1710–2690 MHz
Input Impedance	50 Ω
VSWR	≤ 4.0
Gain	≤ 3.0 dBi
Polarization Type	Linear

Mechanical Specifications

Antenna Size	35.0 mm (L) \times 8.5 mm (W) \times 3.0 mm (H)
Carrier	FR4
Connector Type	SMD
Working Temperature	-40 $^{\circ}$ C to +85 $^{\circ}$ C
Radome Color	Black

4 Overall Performance

4.1. Test Environment

- KEYSIGHT VNA Network Analyzer E5063A 100 kHz – 6.5 GHz.
- RayZone®2800 Chamber 5G (FR1) SISO/MIMO, 400 MHz – 6.0 GHz.



4.2 VSWR

Board length 110 mm

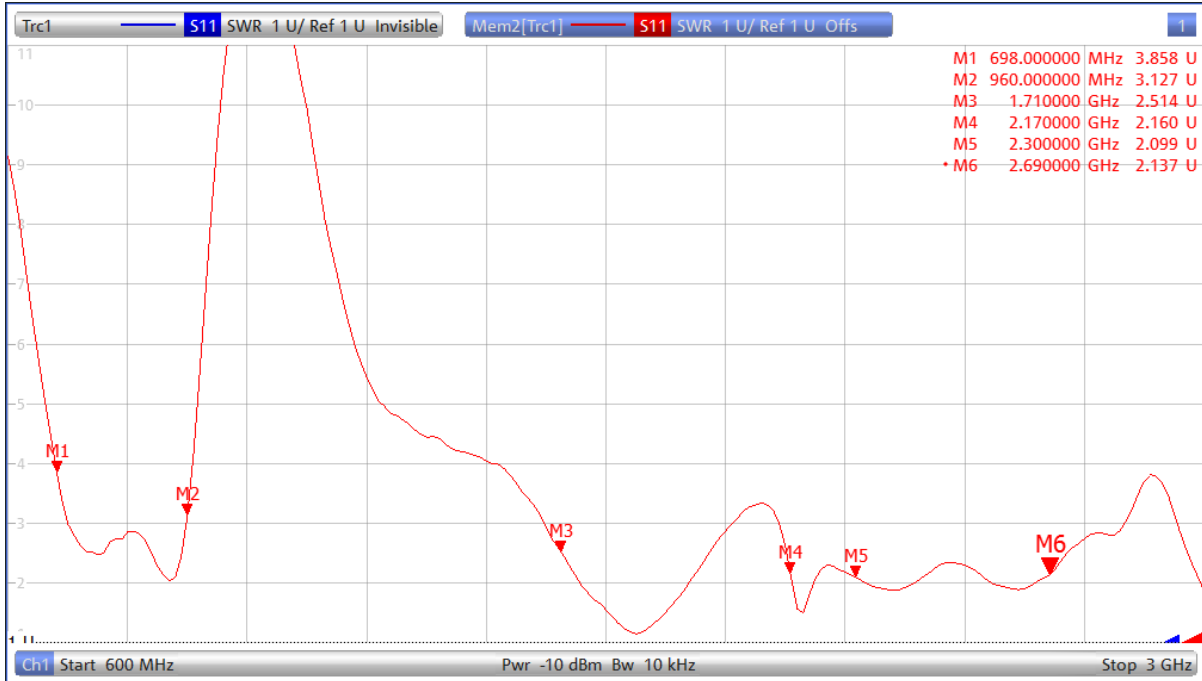

Frequency (MHz)	698	960	1710	2170	2300	2690
VSWR	3.85	3.12	2.51	2.16	2.09	2.13

4.3 Return Loss

Board length 110 mm



Frequency (MHz)	698	960	1710	2170	2300	2690
Return Loss	-4.54	-4.99	-13.12	-6.50	-14.55	-9.46

4.4 Efficiency

Board length 110 mm

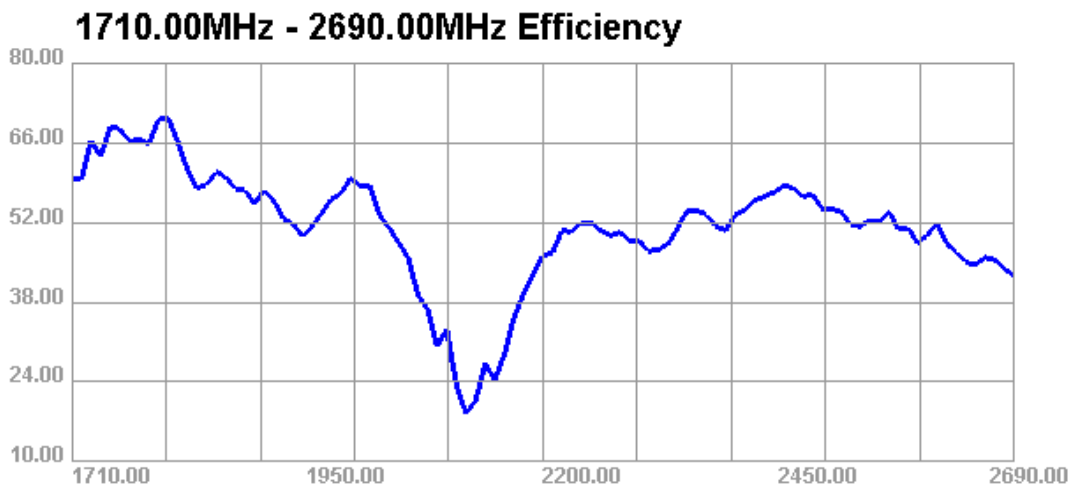
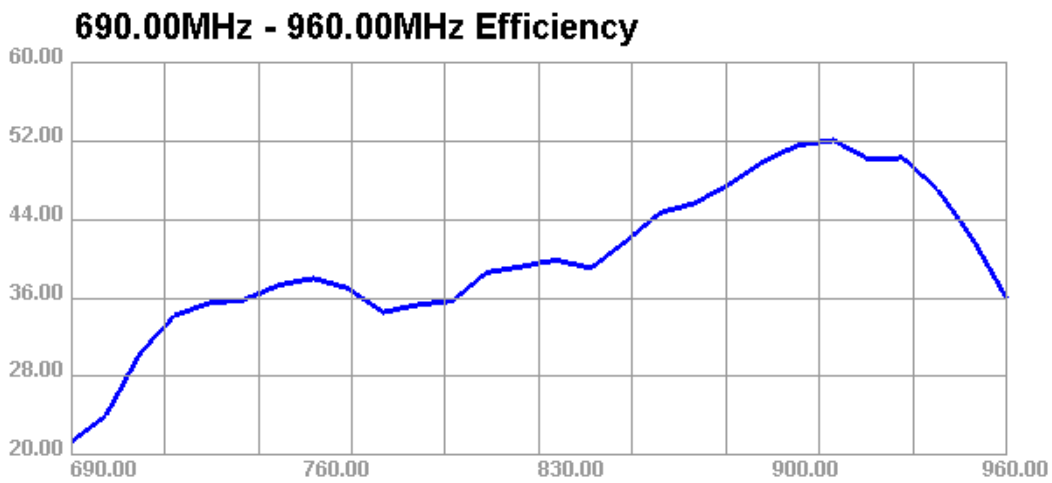

Frequency (MHz)	698	960	1710	2170	2300	2690
Efficiency (%)	21.4	36.0	59.8	35.3	48.8	42.7

4.5 Gain

Board length 110 mm

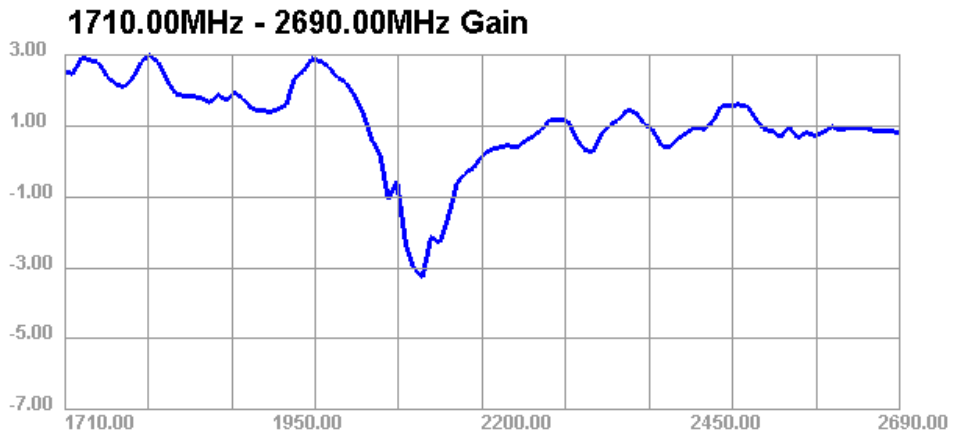
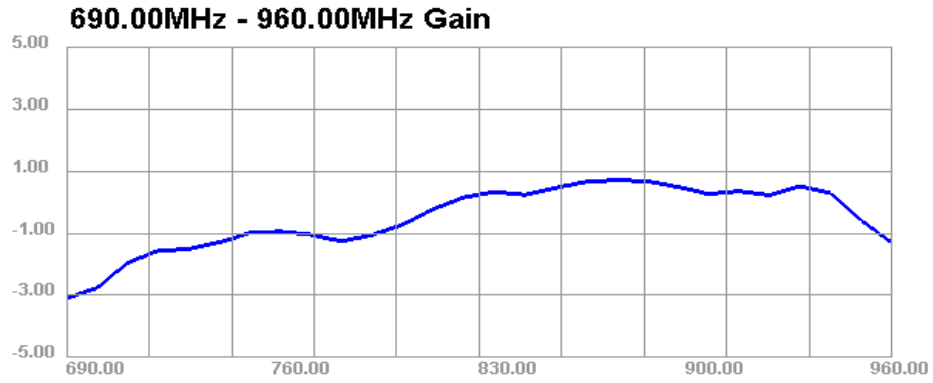

Frequency (MHz)	698	960	1710	2170	2300	2690
Gain	-2.73	-1.20	1.97	-1.54	1.33	0.95

4.6 Radiation Patterns

Board length 110 mm

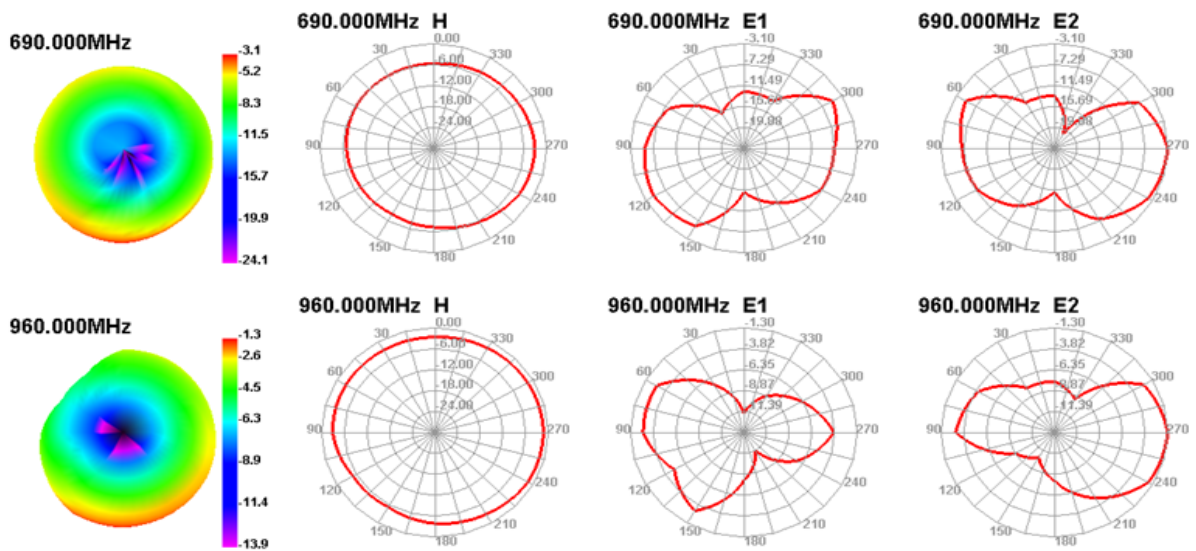
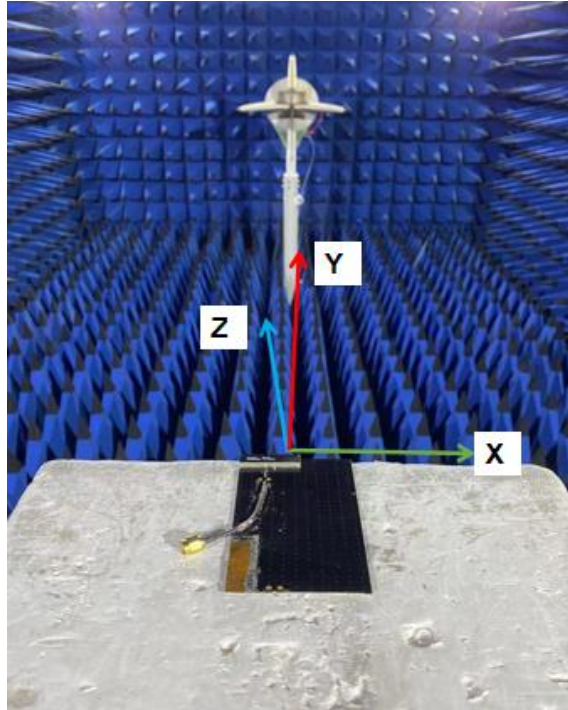

1710.000MHz

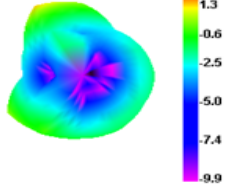

1710.000MHz H

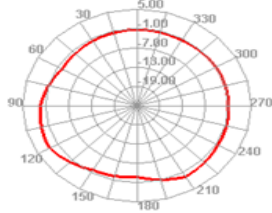

1710.000MHz E1

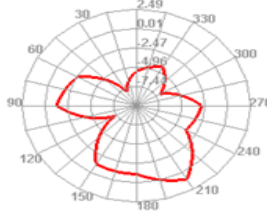

1710.000MHz E2

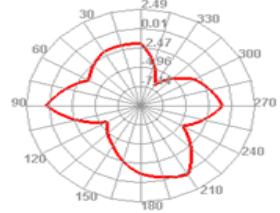

2170.000MHz

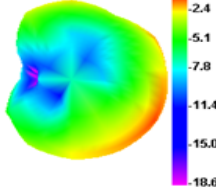

2170.000MHz H

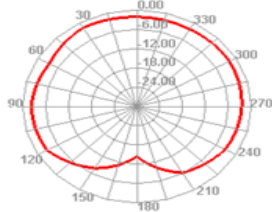

2170.000MHz E1

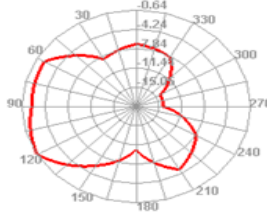

2170.000MHz E2

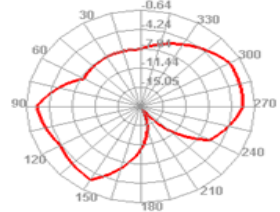

2300.000MHz

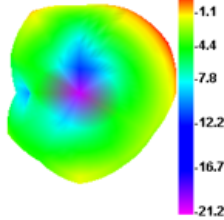

2300.000MHz H

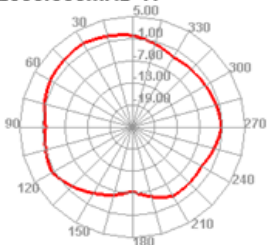

2300.000MHz E1

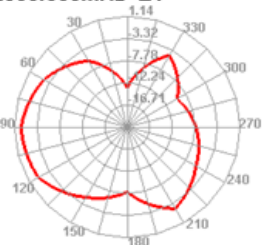

2300.000MHz E2

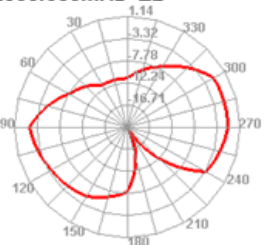

2690.000MHz

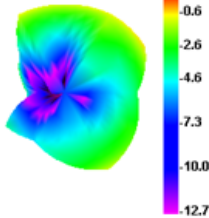

2690.000MHz H

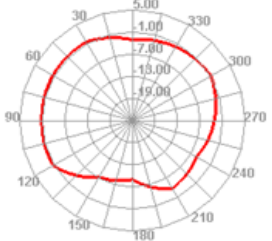

2690.000MHz E1

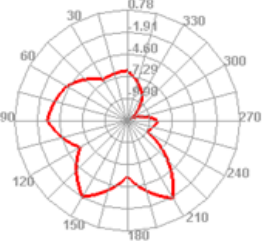

2690.000MHz E2

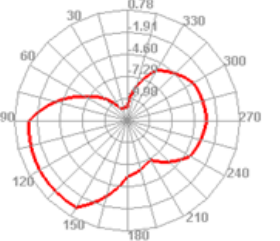

5 Schematic Symbol and Pin Definition

The pin assignment for the antenna is as follows. The antenna has 16 pins and only two work. All other pins are designed for mechanical strength.

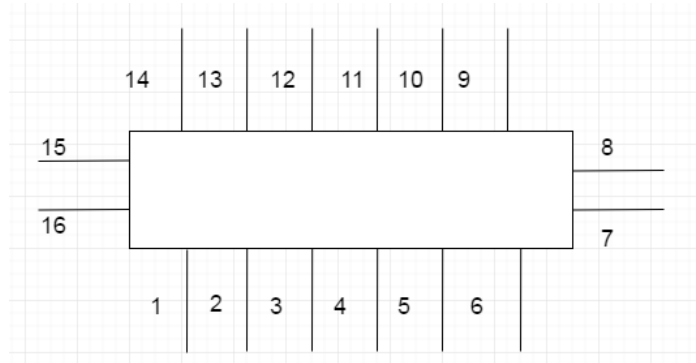

Pin No.	Description
3	Feed
4	Return/GND
1, 2, 5, 6, 7, 8, 9, 10, 11, 12, 13, 14, 15, 16	Not used (Mechanical only)

6 Transmission Line

The characteristic impedance of all transmission lines shall be designed as 50 Ω .

- The length of the transmission lines should be kept to as short as possible.
- Any other part of the RF system, such as transceiver, power amplifiers, etc., shall also be designed with an impedance of 50 Ω .

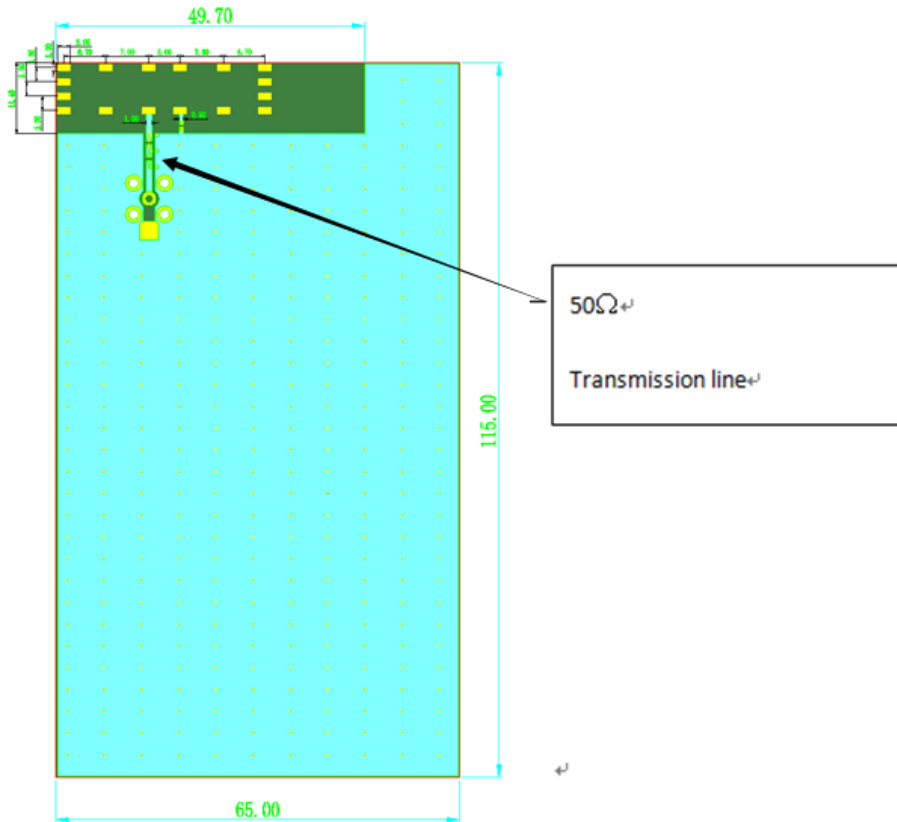

7 Matching Circuit

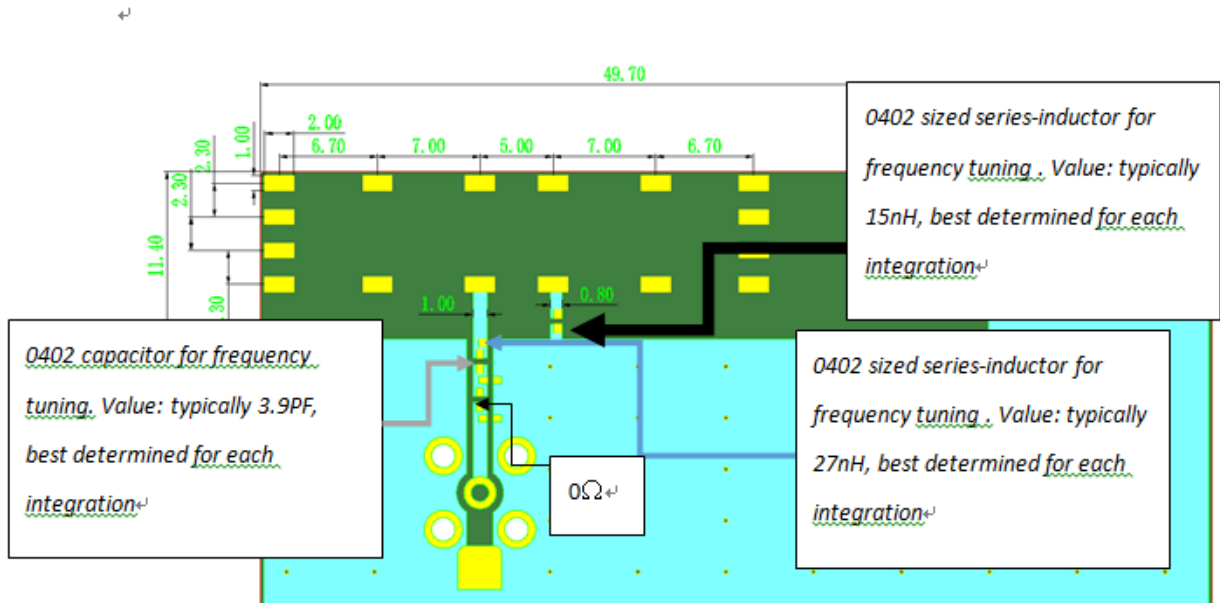

The antenna requires a matching circuit that must be optimized for each product. The matching circuit will require up to six components and the following circuit should be designed into the host PCB. Not all components may be required but should be included as a precaution. The matching network must be placed close to the antenna feed to ensure it is more effective in tuning the antenna.

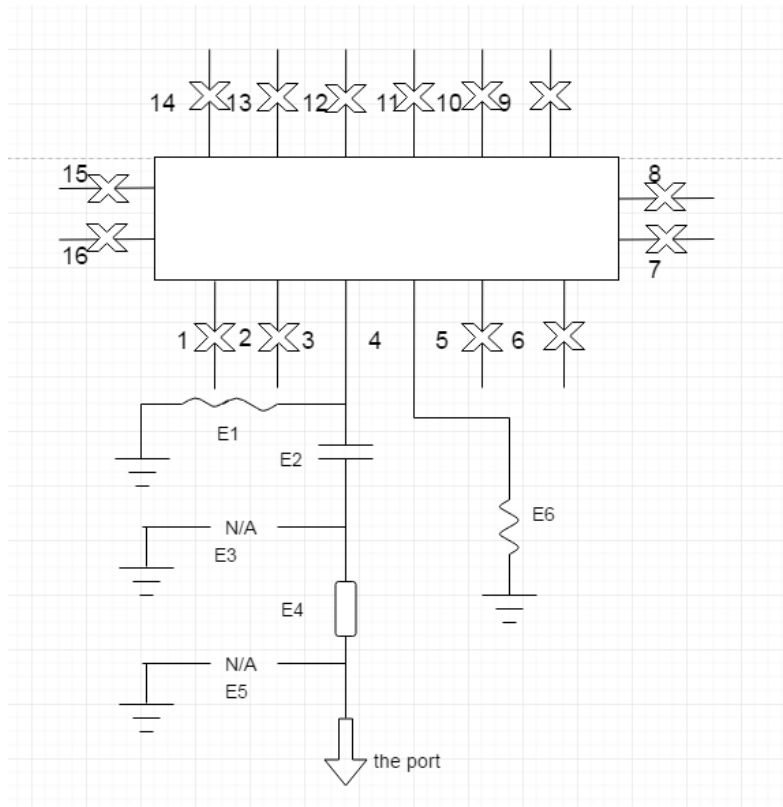

	Type	Value
E1	Inductor	27 nH
E2	Capacitor	3.9 pF
E3	N/A	N/A
E4	Capacitance	0 Ω
E5	N/A	N/A
E6	Inductor	15 nH

8 Host PCB Requirement

The printed circuit board of the host must ensure that the antenna clearance area meets the antenna specifications. It is suggested that putting the antenna in the corner of the PCB.

An example of a PCB layout shown as below:

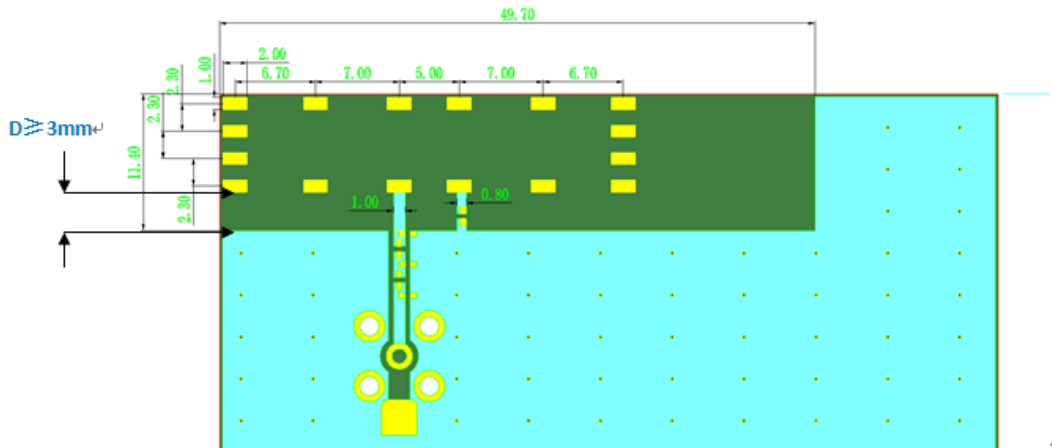

Gap D is required from the edge of the antenna to the ground plane. This should be maintained along the edge of the antenna placement, **minimum value is 3 mm**.

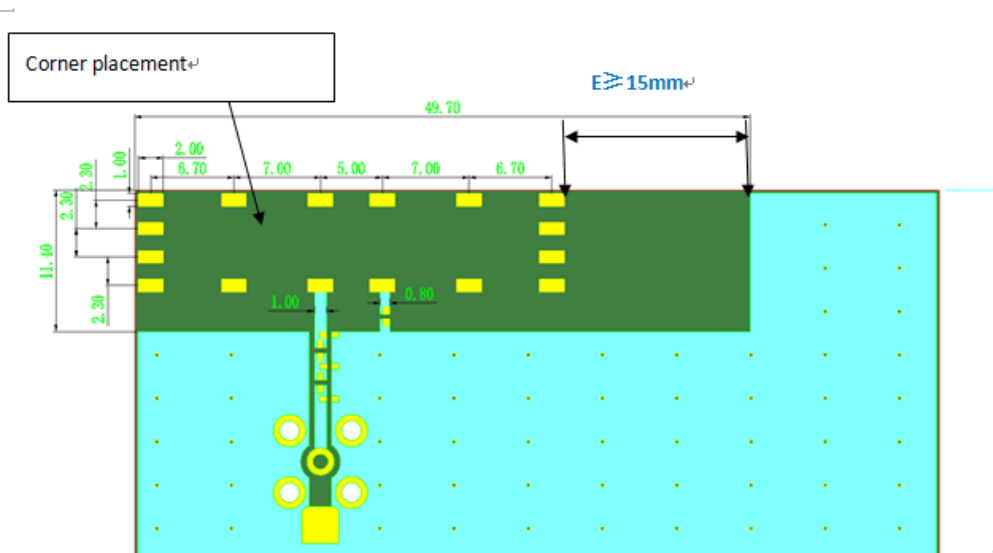

Gap E is required from the edge of the antenna to the ground plane or PCB traces, **minimum value is 15 mm**.

8.1. Host PCB Size

The performance of the low frequency section depends on the length of the ground plane. Reducing GND length will directly impact on the performance of low frequency band.

Taking antenna efficiency measurement results on different GND sizes as an example:

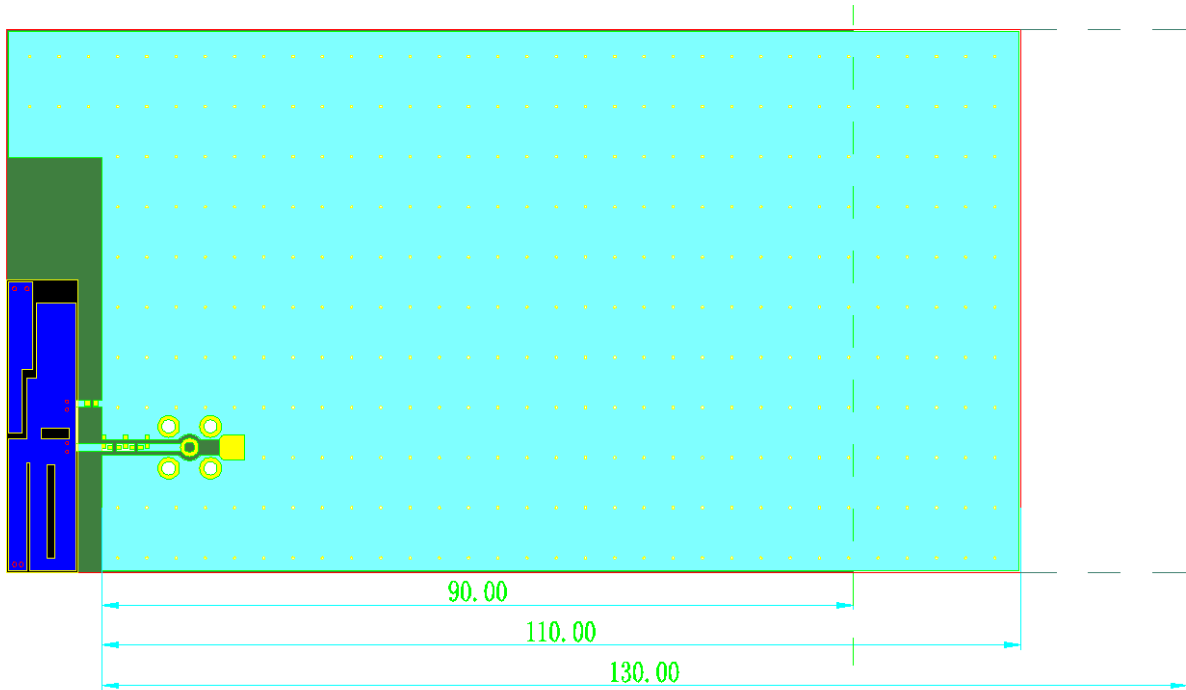

Passive Efficiency vs. PCB length
All results measured in Quectel's anechoic chamber

- Board length 90 mm

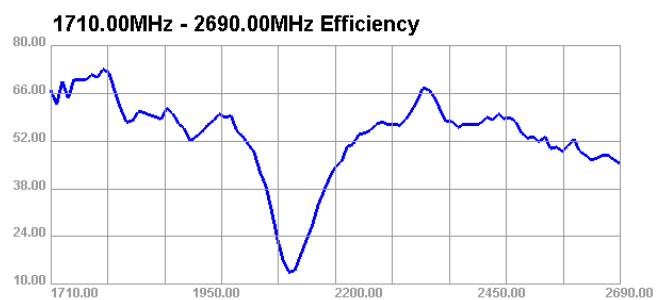
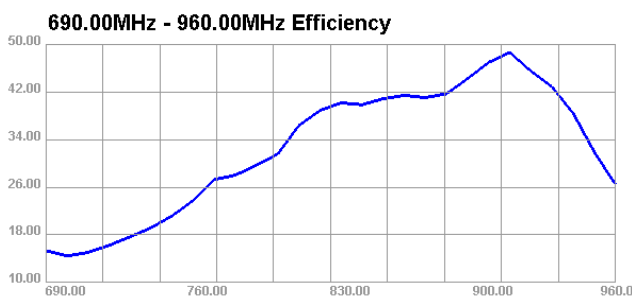

● Board length 110mm

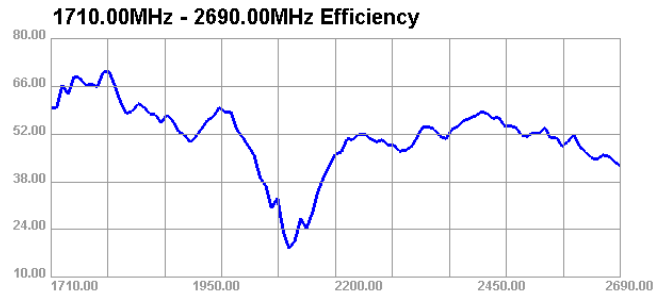
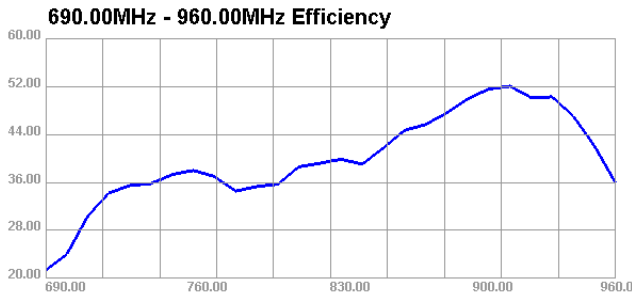

● Board length 130 mm

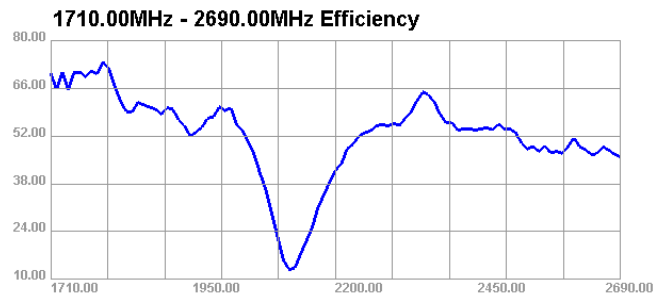
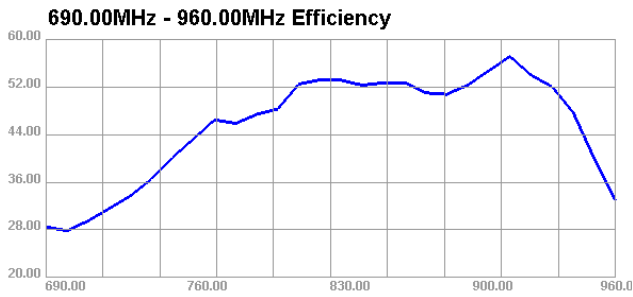

9 Soldering Temperature

Phase	Profile Features	PB-Free Assembly (Max.)
RAMP-UP	Avg. Ramp-up Rate (T _{smax} to T _p)	3 °C/second (max.)
PREHEAT	Temperature Min. (T _{smin})	150 °C
	Temperature Max. (T _{smax})	180 °C
	Time (T _{smin} to T _{smax})	120 seconds max.
REFLOW	Temperature (T _L)	210 °C
	Total Time above T _L (t _l)	50 seconds max.
PEAK	Temperature (T _p)	260 °C
	Time (t _p)	10 seconds max.
RAMP-DOWN	Rate	5 °C/second max.

10 Reflow Profile

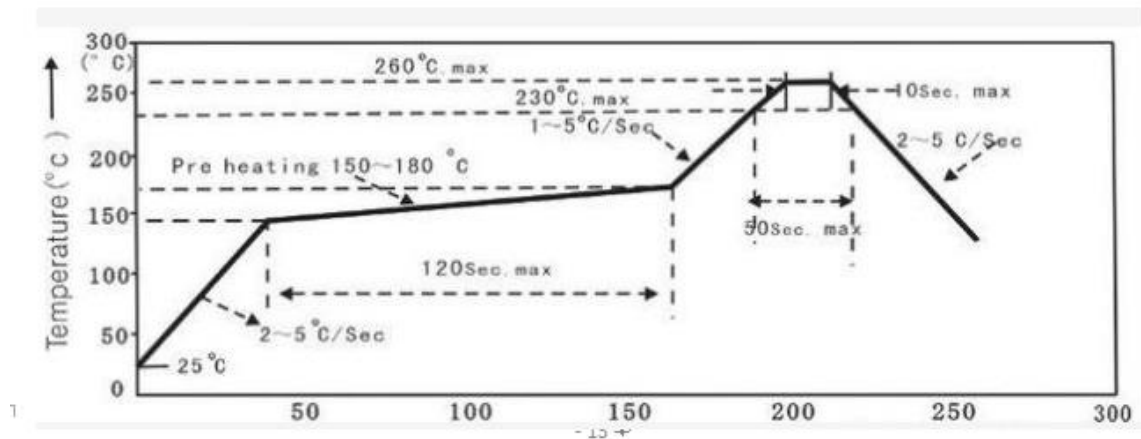

11 Package

- Quantity/Reel: 1000 pcs/Reel
- Carrier tape dimensions (mm)

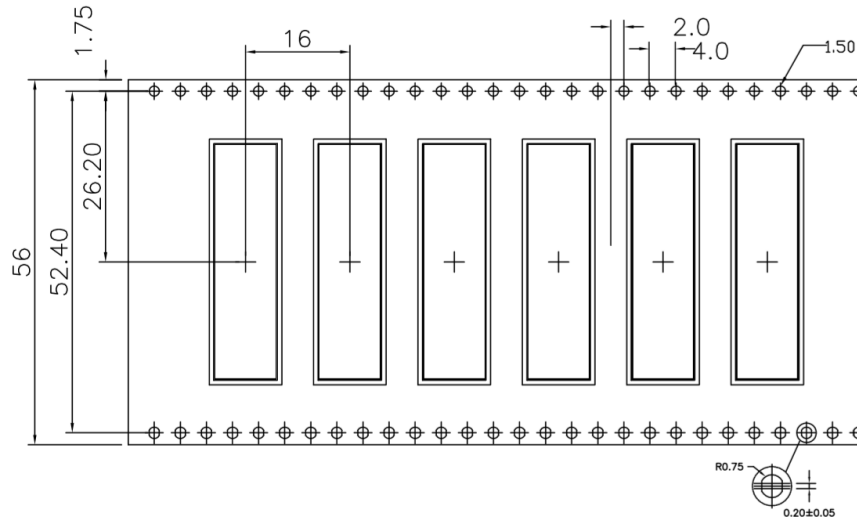

- Taping reel dimensions (mm)

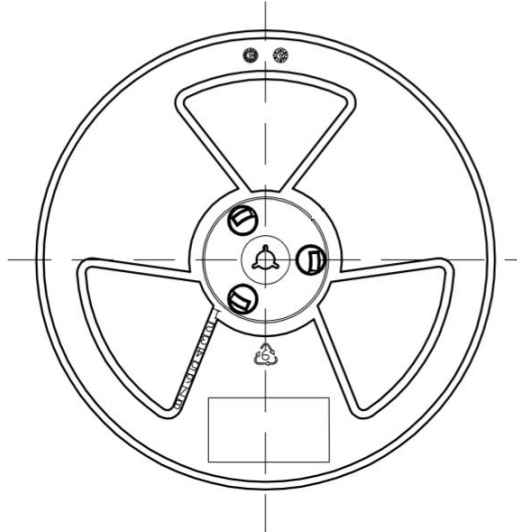

330 mm x 100 mm x 56.4 mm

12 Product Size

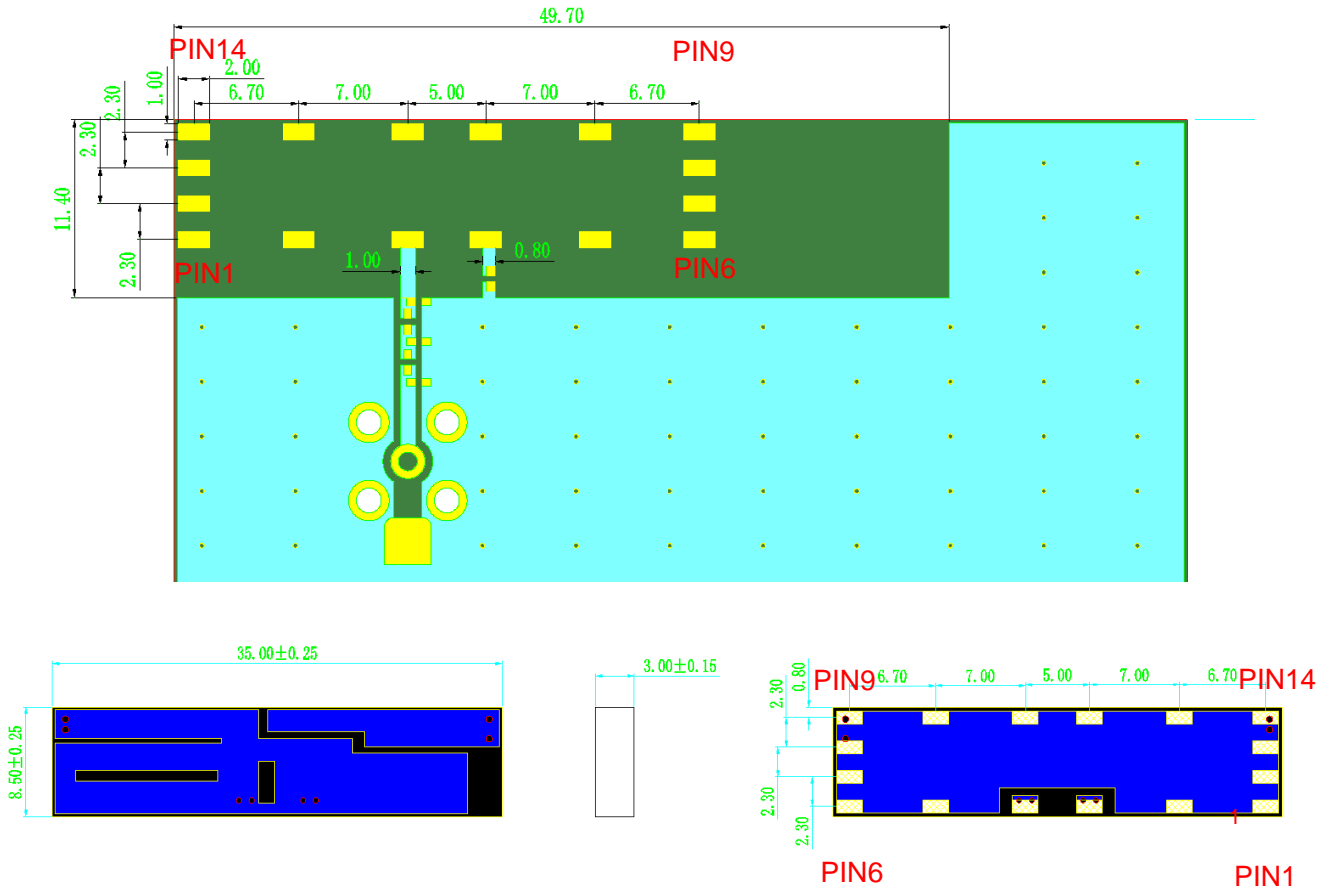

Please contact us for any unmarked size information.