

"Schutzvermerk nach DIN ISO 16016 beachten" "Please pay attention to copyright note DIN ISO 16016"

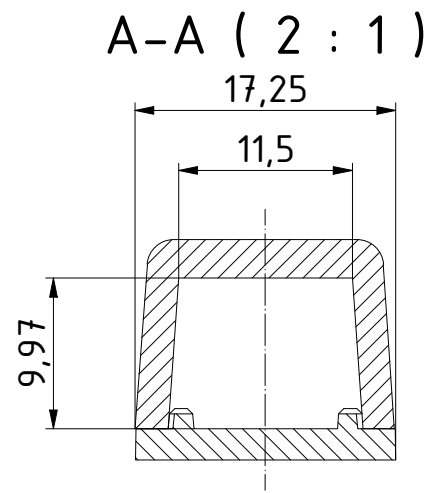

ISO (1 : 1)

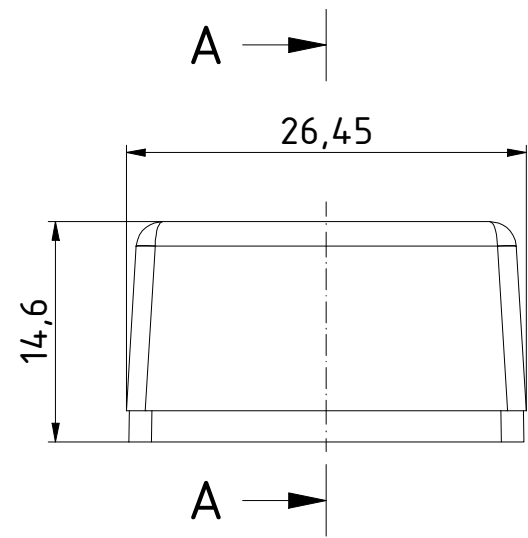
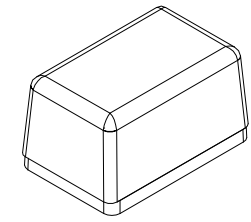

Unterteil/
Base

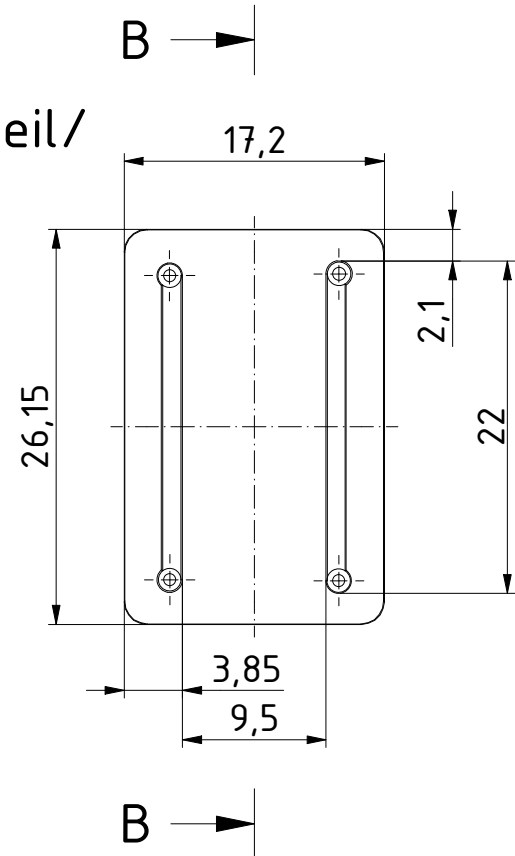

B-B (2 : 1)

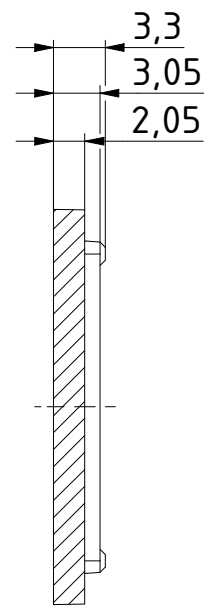

Oberteil/
Lid

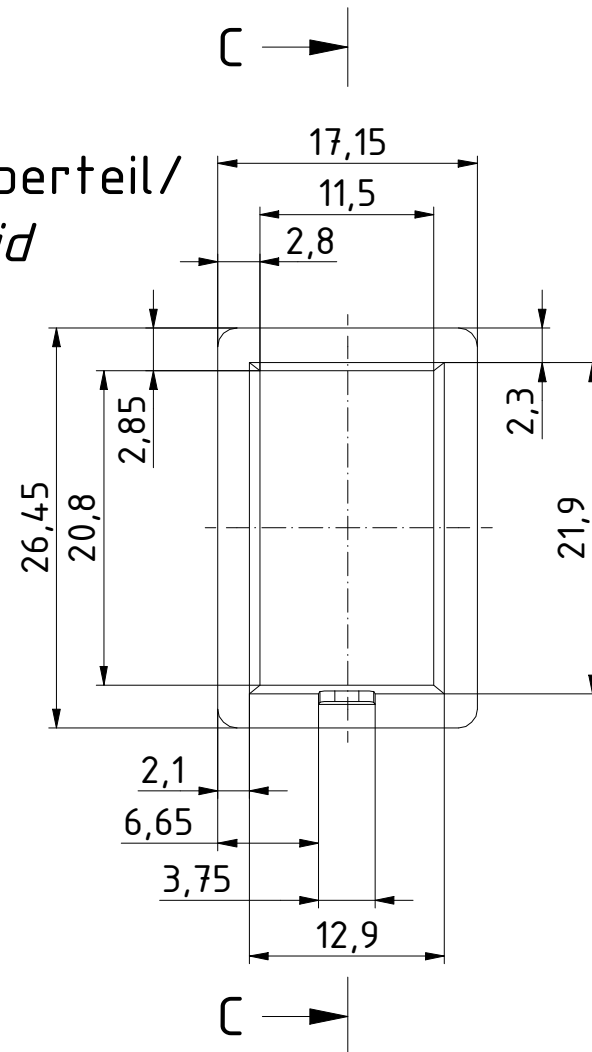

C-C (2 : 1)

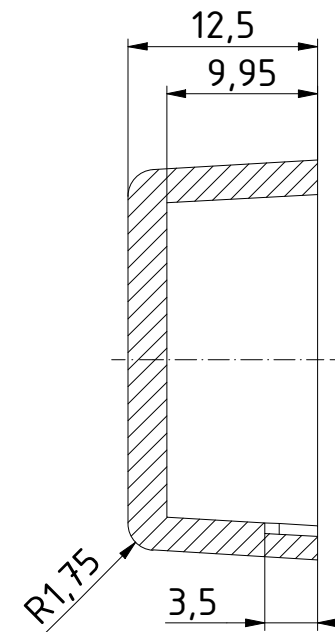

				Zeichnungs-Nr. / Drawing-No.: 3K 5455.018.01	
				Datum/Date	Name/name
				Gezeichnet	05.07.2018 AR
				Kontrolliert	
				Norm	
				2504210.idw	
				2:1	
				A3	
Status	Ä.Nr./Alt.No	Datum/Date	Name		

4U-030202

Katalogzeichnung/Catalogue drawing