

„Schutzvermerk nach DIN ISO 16016 beachten“

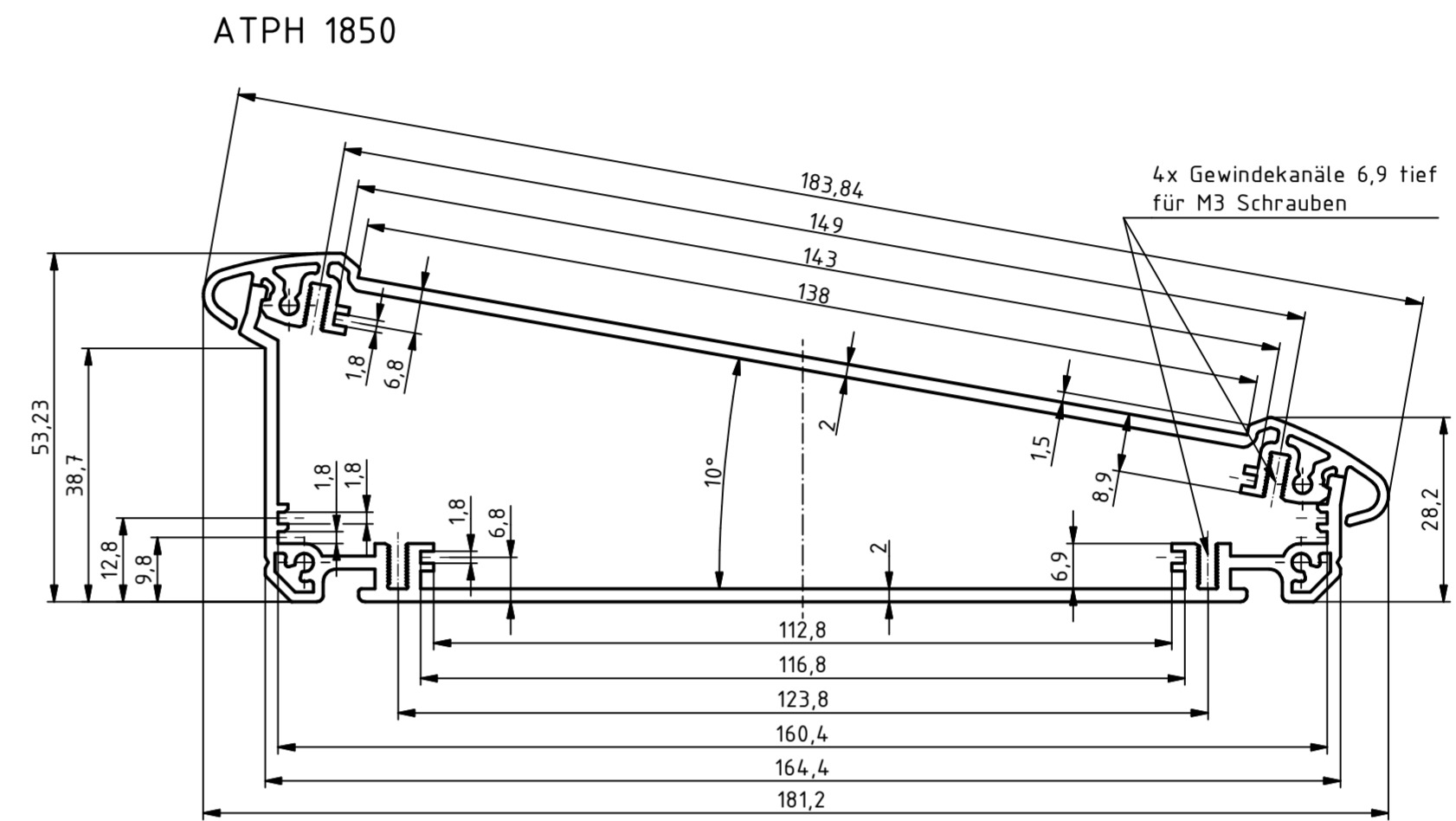

Maßstab: 1:1	
Zchn.Nr.:	
Artikel: ATPH 1850-250 / ATD 1850	
Katalogzeichnung	
Ä.Nr.:	Datum:
DISK: 92850250.MT1_ATPH 1850-250 + ATD 1850.idw	
Datum: 04.09.2012 JL	

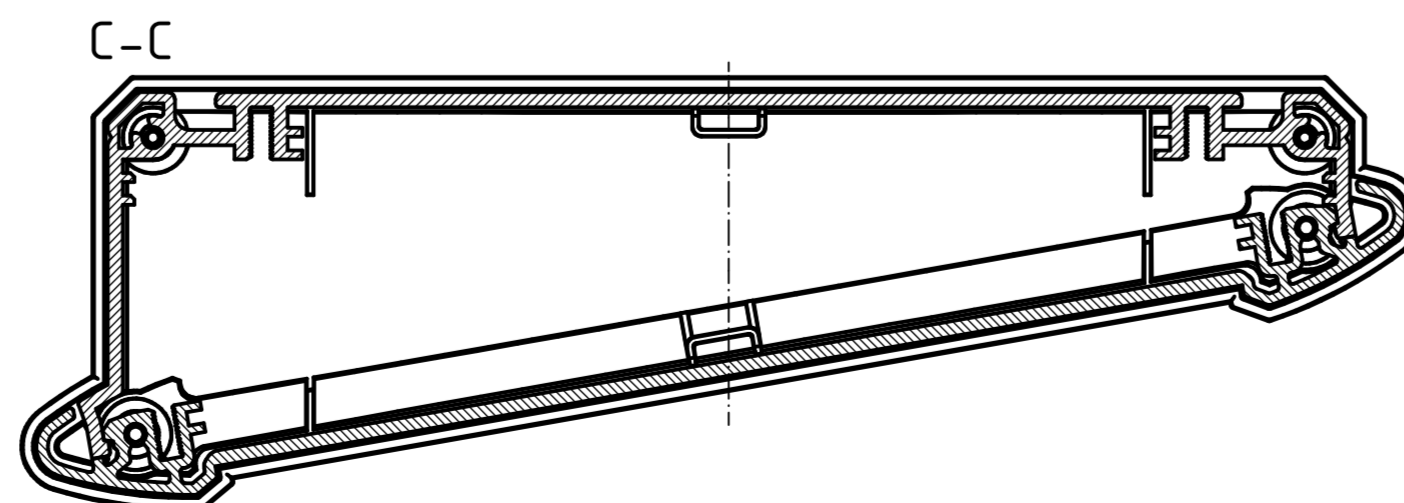
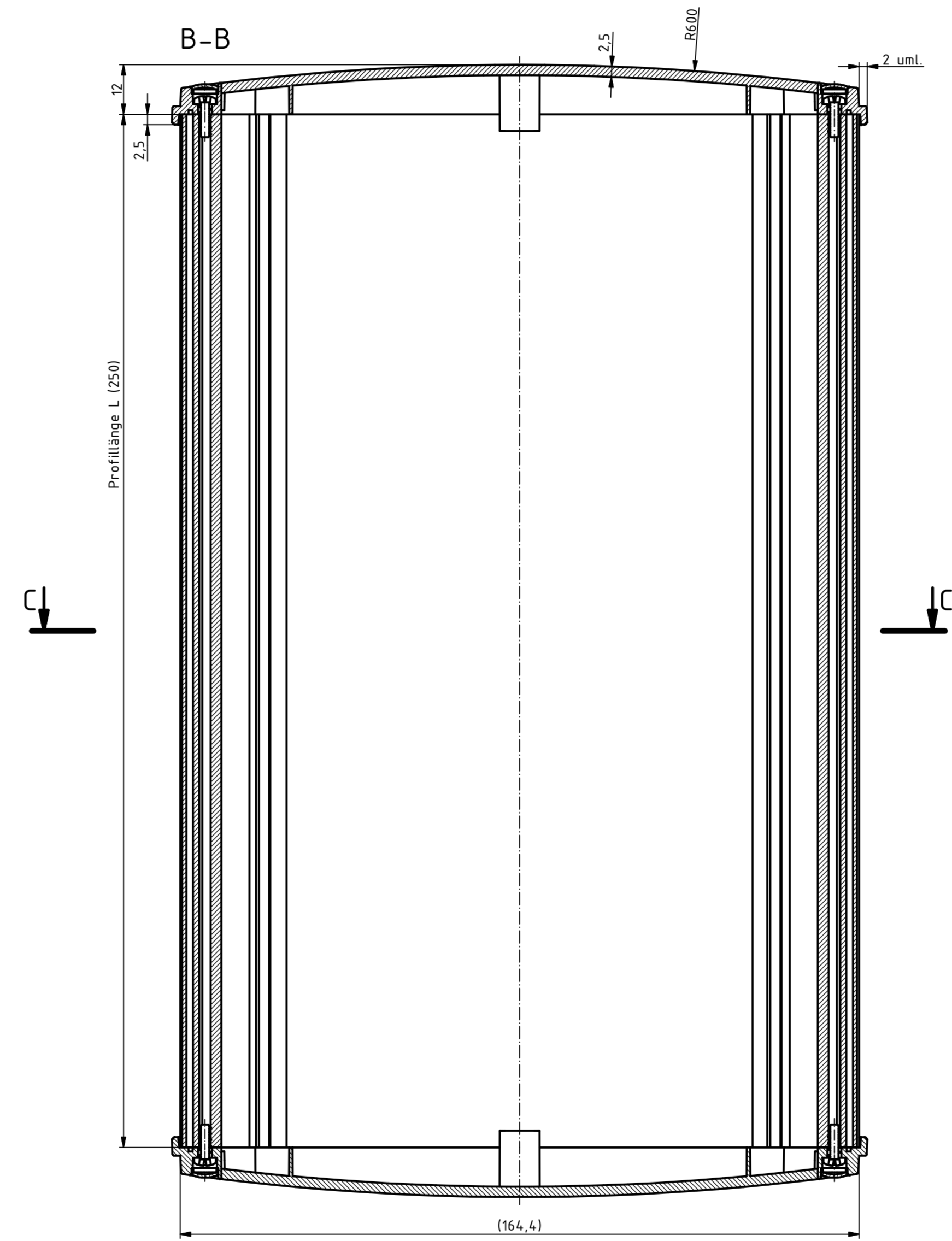
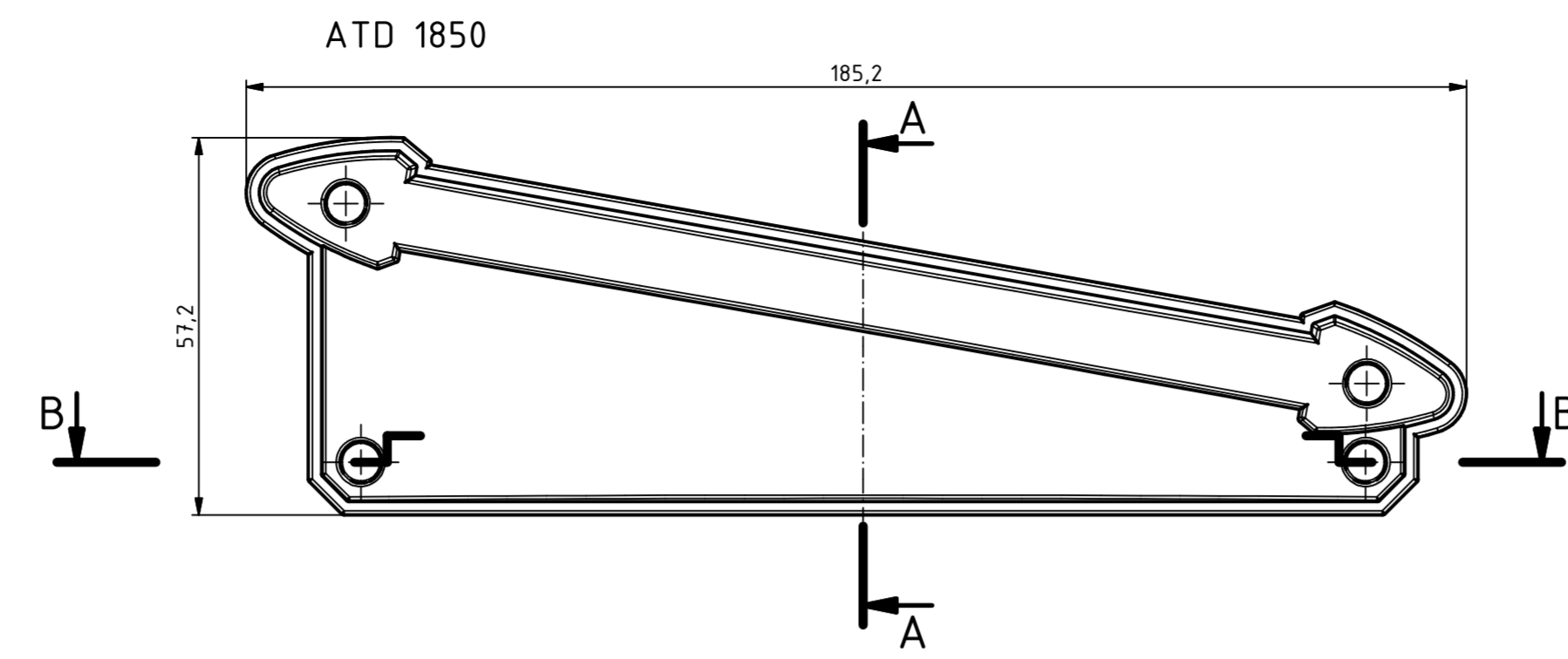
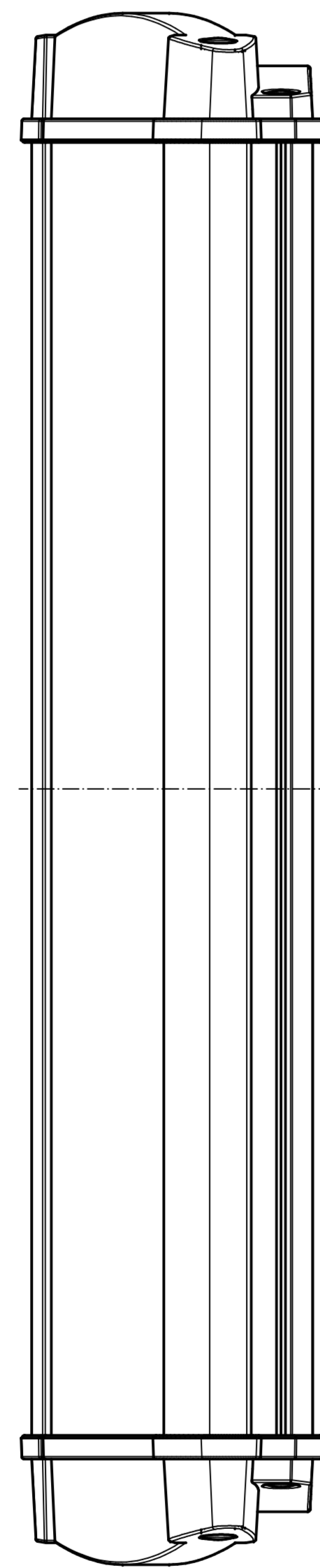
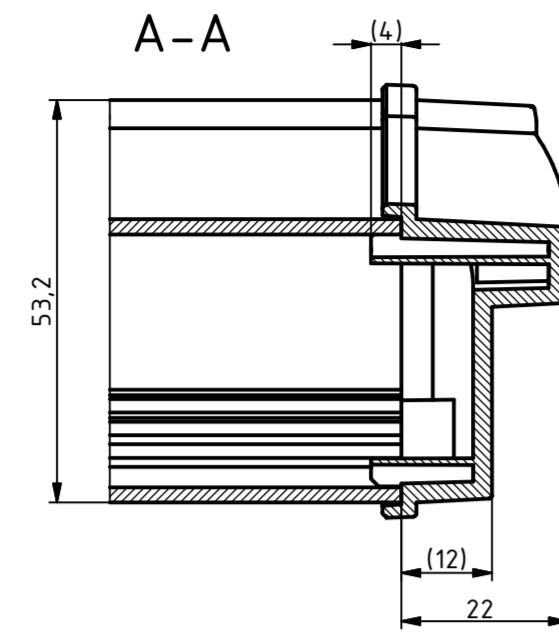

BOPLA
A Phoenix Mecano Company