

Spec. No.	ICR18650-26JM	Version No.	1.0
-----------	---------------	-------------	-----



SPECIFICATION OF PRODUCT

1. Customer: Lexel Battery(Shenzhen)
2. Product: SAMSUNG SDI in Malaysia
3. Model : ICR18650-26JM
4. Received Marking

Division			
Signature			
Date	/ /	/ /	/ /

5. Date of Application (YY/MM/DD) : 2015/9/8

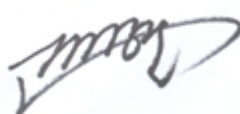
6. Supplier: **SAMSUNG SDI Co., Ltd. Energy Division.**

Issued	Approved
	
J,H.KO	Michael.rim

Spec. No.	ICR18650-26JM	Version No.	1.0
-----------	---------------	-------------	-----

SPECIFICATION OF PRODUCT

for Lithium-ion Rechargeable Cell

Model : ICR18650-26JM

Sep. 11, 2014

**Samsung SDI Co.,Ltd.
Energy Business Division**

Spec. No.	ICR18650-26JM	Version No.	1.0
-----------	---------------	-------------	-----

Revision history

Revision No.	Date('yr-m-d)	Page	Item	Description	Changes /Author
V-1.0	'14-09-11			First version	Jongsik Jung

Spec. No.	ICR18650-26JM	Version No.	1.0
-----------	---------------	-------------	-----

1. Scope

This product specification has been prepared to specify the rechargeable lithium-ion cell ('cell') to be supplied to the customer by Samsung SDI Co., Ltd.

2. Description and Model

2.1 Description Cell (lithium-ion rechargeable cell)

2.2 Model ICR18650-26JM

3. Nominal Specifications

Item	Specification
3.1 Nominal Capacity	2600mAh (0.2C, 2.75V discharge)
3.2 Minimum Capacity	2550mAh(0.2C, 2.75V discharge)
3.3 Charging Voltage	4.2 ± 0.05 V
3.4 Nominal Voltage	3.63V
3.5 Charging Method	CC-CV (constant voltage with limited current)
3.6 Charging Current	Standard charge: 1300mA Rapid charge : 2600mA
3.7 Charging Time	Standard charge : 3hours Rapid charge : 2.5hours
3.8 Max. Charge Current	2600mA(ambient temperature 25℃)
3.9 Max. Discharge Current	5200mA(ambient temperature 25℃)
3.10 Discharge Cut-off Voltage	2.75V
3.11 Cell Weight	45.0g max
3.12 Cell Dimension	Height : 65.00mm max Diameter : 18.40mm max
3.13 Operating Temperature	Charge : 0 to 45℃ Discharge: -20 to 60℃
3.14 Storage Temperature	1 year : -20~25℃ (1*) 3 months : -20~45℃ (1*) 1 month : -20~60℃ (1*)

Note (1): If the cell is kept as ex-factory status (50% of charge),
the capacity recovery rate is more than 80%.

Spec. No.	ICR18650-26JM	Version No.	1.0
-----------	---------------	-------------	-----

4. Outline Dimensions

See the Fig. 1

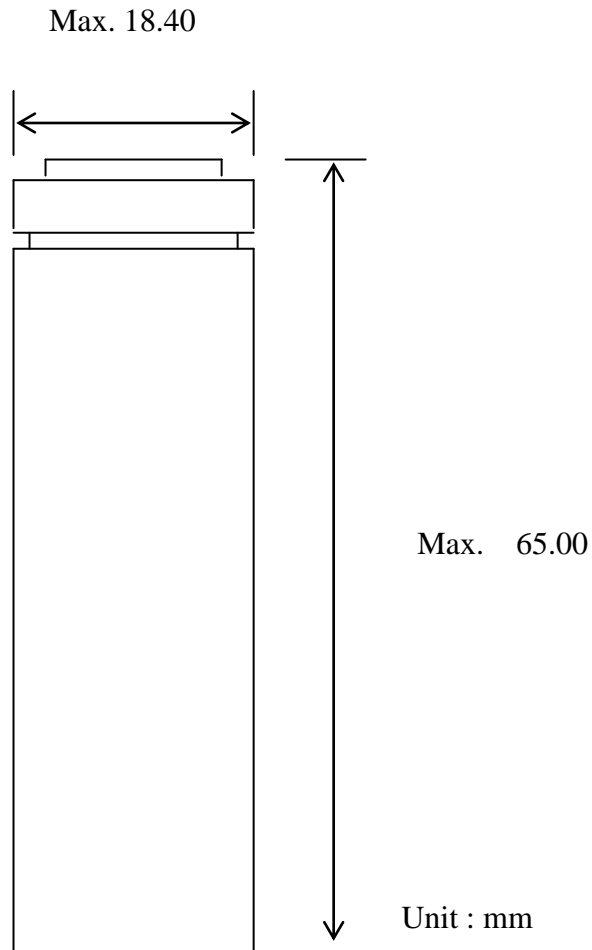

Fig.1. Outline Dimensions of ICR18650-26JM

Spec. No.	ICR18650-26JM	Version No.	1.0
-----------	---------------	-------------	-----

5. Appearance

There shall be no such defects as scratch, rust, discoloration, leakage which may adversely affect commercial value of the cell.

6. Standard Test Conditions

6.1 Environmental Conditions

Unless otherwise specified, all tests stated in this specification are conducted at temperature $25\pm 5^{\circ}\text{C}$ and humidity $65\pm 20\%$.

6.2 Measuring Equipment

(1) Ammeter and Voltmeter

The ammeter and voltmeter should have an accuracy of the grade 0.5 or higher.

(2) Slide caliper

The slide caliper should have 0.01 mm scale.

(3) Impedance meter

The impedance meter with AC 1kHz should be used.

7. Characteristics

7.1 Standard Charge

This "Standard Charge" means charging the cell with charge current 1300mA and constant voltage 4.2V at 25°C for 3hours.

7.2 Standard Discharge Capacity

The standard discharge capacity is the initial discharge capacity of the cell, which is measured with discharge current of 520mA with 2.75V cut-off at 25°C within 1hour after the standard charge.

$$\text{Standard Discharge Capacity} \geq 2550\text{mAh}$$

7.3 Initial internal impedance

Initial internal impedance measured at AC 1kHz after rated charge.

$$\text{Initial internal impedance} \leq 100\text{m}\Omega$$

7.4 Temperature Dependence of Discharge Capacity

Capacity comparison at each temperature, measured with discharge constant current 520mA and 2.75V cut-off after the standard charge is as follows.

Charge Temperature	Discharge temperature			
	-10°C	0°C	25°C	40°C
Relative Capacity	50%	80%	100%	80%

Note: If charge temperature and discharge temperature is not the same, the interval for temperature change is 3 hours.

Spec. No.	ICR18650-26JM	Version No.	1.0
-----------	---------------	-------------	-----

Percentage as an index of the capacity at 25 °C(=2550mAh) is 100%.

7.5 Temperature Dependence of Charge Capacity

Capacity comparison at each temperature, measured with discharge constant current 520mA and 2.75V cut-off after the standard charge is as follows.

	Charge temperature			Discharge temperature 25 °C
	0 °C	25 °C	45 °C	
Relative Capacity	80%	100%	80%	

Note: If charge temperature and discharge temperature is not the same, the interval for temperature change is 3 hours.

Percentage as an index of the capacity at 25 °C(=2550mAh) is 100%.

7.6 Charge Rate Capabilities

Discharge capacity is measured with constant current 520mA and 2.75V cut-off after the cell is charged with 4.2V as follows.

	Charge Condition			
Current	0.2C (520mA)	0.5C (1300mA)	1.0C (2600mA)	2.0C (5200mA)
Cut-off	7h or 0.05C	2.5h or 0.05C	2.5h or 0.05C	2.5h or 0.05C
Relative Capacity	100%	95%	90%	80%

Note: Percentage as an index of the capacity at 25 °C(=2550mAh) is 100%.

7.7 Discharge Rate Capabilities

Discharge capacity is measured with the various currents in under table and 2.75V cut-off after the standard charge.

	Discharge Condition			
Current	0.2C (520mA)	0.5C (1300mA)	1.0C (2600mA)	2.0C (5200mA)
Relative Capacity	100%	95%	90%	80%

Note: Percentage as an index of the capacity at 25 °C(=2550mAh) is 100%.

7.8 Cycle Life

Each cycle is an interval between the charge (charge current 1300mA) with 2.5h or 0.05C cut-off and the discharge (discharge current 1300mA) with 2.75V cut-off.

Spec. No.	ICR18650-26JM	Version No.	1.0
-----------	---------------	-------------	-----

Capacity after 299cycles and plus 1 day, measured under the same condition in 7.2

Capacity \geq 1785mAh(70% of the capacity at 25°C)

7.9 Storage Characteristics

Capacity after storage for 30days at 25°C from the standard charge, measured with discharge current 1300mA with 2.75V cut-off at 25°C.

Capacity retention(after the storage) \geq 2040mAh (80% of the capacity at 25°C)

7.10 Status of the cell as of ex-factory

The cell should be shipped in 50% charged state. In this case, OCV is from 3.55V to 3.75V.

8. Mechanical Characteristics

8.1 Drop Test

Test method: Cell(as of shipment or full charged) drop onto the oak-board (thickness: \geq 30mm) from 1.5m height at a random direction 6 times.

Criteria: No leakage

8.2 Vibration Test

Test method: Cell(as of shipment) is vibrated along 2 mutually perpendicular axes with total excursion of 1.6mm and with frequency cycling between 10Hz and 55Hz by 1Hz/min.

Criteria: No leakage

9. Safety

9.1 Overcharge Test

Test method: To charge the standard charged cell with 12V and 2.6A at 25°C for 2.5 hours.

Criteria: No fire, and no explosion.

9.2 External Short-circuit Test

Test method: To short-circuit the standard charged cell by connecting positive and negative terminal by 60~100mΩ wire for 3hours.

Criteria: No fire, and no explosion.

9.3 Reverse Charge Test

Test method: To charge the standard charged cell with charge current 2.6A By -12V for 2.5 hours.

Criteria: No fire, and no explosion.

9.4 Heating Test

Test method: To heat up the standard charged cell at heating rate 5°C per minute up to

Spec. No.	ICR18650-26JM	Version No.	1.0
-----------	---------------	-------------	-----

130 °C and keep the cell in oven for 60 minutes.
Criteria: No fire, and no explosion.

10. Warranty

Samsung SDI will be responsible for replacing the cell against defects or poor workmanship for 15 months from the date of shipping. Any other problem caused by malfunction of the equipment or mix-use of the cell is not under this warranty.

The warranty set forth in proper using and handling conditions described above and excludes in the case of a defect which is not related to manufacturing of the cell.

11. Others

11.1 Storage for a long time

If the cell is kept for a long time(3 months or more), It is strongly recommended that the cell is preserved at dry and low-temperature.

11.2 Other

Any matters that specifications does not have, should be conferred with between the both parties.

11.3 PTC Specification

	PTC Specification (in the Cell)			
Item	Hold Current	Resistance	Power Dissipation	Resistance After Trip
Spec.	2.9A	7~16m Ω	Max. 2.5W	Max. 28m Ω

Spec. No.	ICR18650-26JM	Version No.	1.0
-----------	---------------	-------------	-----

12. Packing

See Fig.2,
Package Drawing

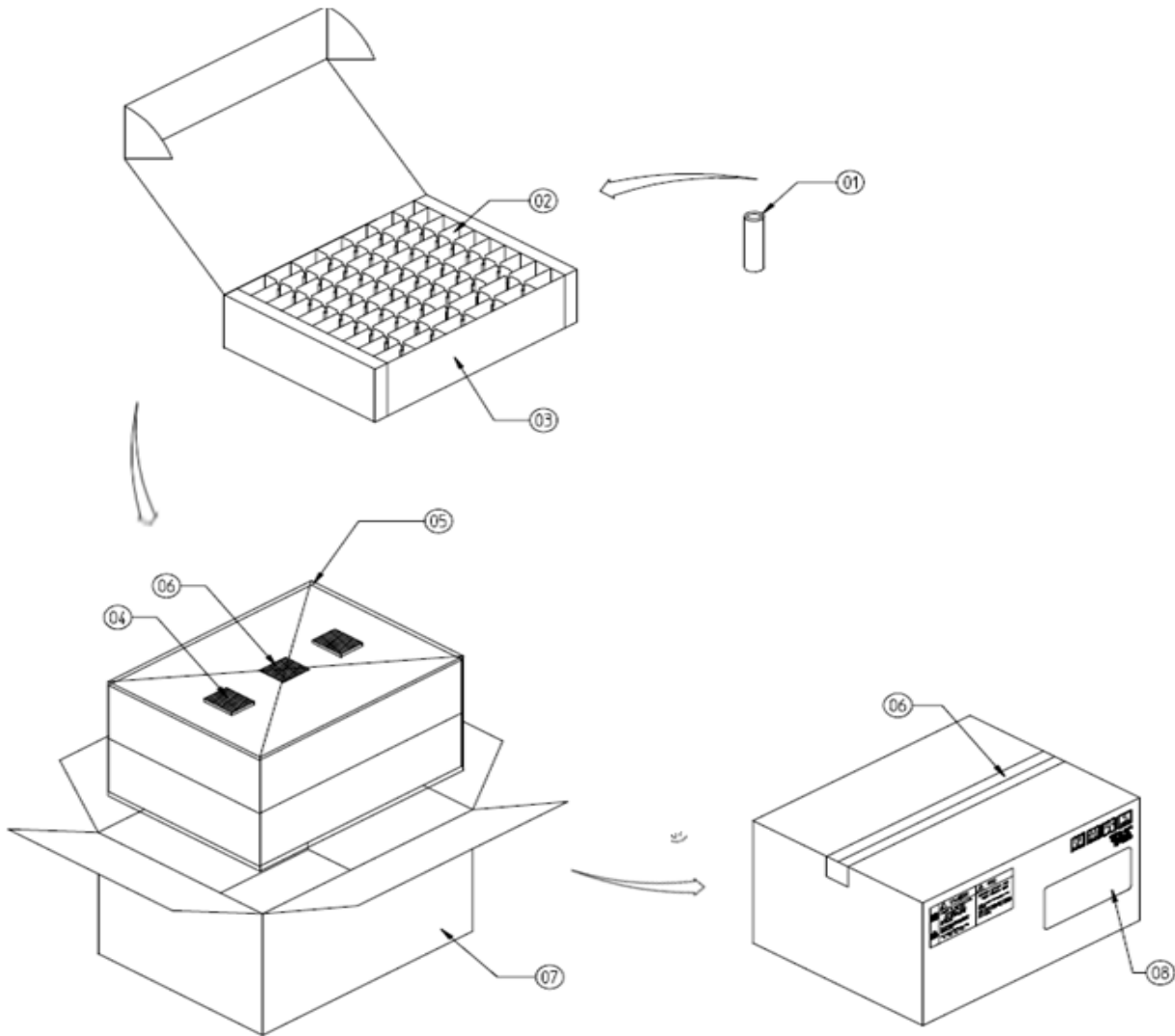

NO	PART NAME	MATERIAL	MATERIAL DIM	Q'TY	TREATMENT
01	INR18650(Ref. Model List)	BARE CELL	#18, H65	200	NONE
02	PACKING GUIDE	MANILA	L192×W191×H67	200	NONE
03	PACKING CASE IN	SW-1(B FLUTE)	L192×W192×H68	2	NONE
04	SILICAGEL	SI	L50×W50.3G	2	NONE
05	PE BAG(LARGE)	PE	L500×W450×T0.028	1	NONE
06	TAPE	PE(OPP)	W50×T0.05	1	NONE
07	PACKING CASE OUT	DW-1(BA FLUTE)	L225×W214×H164	1	NONE
08	LABEL	ART PAPER	L52×W100	1	NONE

Fig.2. Package Drawing

Spec. No.	ICR18650-26JM	Version No.	1.0
-----------	---------------	-------------	-----

Proper Use and Handling of Lithium Ion Cells

See before using lithium-ion cell

Supplied by

Samsung SDI Co., Ltd.

1. General

This document has been prepared to describe the appropriate cautions and prohibitions, which the customer should take or employ when the customer uses and handles the lithium ion cell to be manufactured and supplied by Samsung SDI Co., Ltd., in order to obtain optimum performance and safety.

2. Charging

2.1 Charging current

Charging current should be less than maximum charge current specified in the product specification.

2.2 Charging voltage

Charging should be done by voltage less than that specified in the product specification.

2.3 Charging time

Continuous charging under appropriate voltage does not cause any loss of characteristics. However, the charge timer is recommended to be installed from a safety consideration, which shuts off further charging at time specified in the product specification.

2.4 Charging temperature

The cell should be charged within a range of specified temperatures in the product specification.

2.5 Reverse charging

The cell should be connected, confirming that its poles are correctly aligned. Inverse charging should be strictly prohibited. If the cell is connected improperly, it may be damaged.

3. Discharging

3.1 Discharging

3.1.1 The cell should be discharged at less than maximum discharge current specified in the product specification.

3.2 Discharging temperature

3.2.1 The cell should be discharged within a range of temperatures specified in

Spec. No.	ICR18650-26JM	Version No.	1.0
-----------	---------------	-------------	-----

the product specification.

3.2.2 Otherwise, it may cause loss of characteristics.

3.3 Over-discharging

3.3.1 The system should equip with a device to prevent further discharging exceeding discharging cut-off voltage specified in the product specification.(over-discharging)

3.3.2 Over-discharging may cause loss of performance, characteristics, of battery function.

3.3.3 Over-discharging may occur by self-discharge if the battery is left for a very long time without any use.

3.3.4 The charger should equip with a device to detect cell voltage and to determine recharging procedures.

4. Storage

4.1 Storage conditions

4.1.1 The cell should be stored within a range of temperatures specified in the product specification.

4.1.2 Otherwise, it may cause loss of characteristics, leakage and/or rust.

4.2 Long-term storage

4.2.1 The cell should be used within a short period after charging because long-term storage may cause loss of capacity by self-discharging.

4.2.2. If long-term storage is necessary, the cell should be stored at lower voltage within a range specified in the product specification, because storage at higher voltage may cause loss of characteristics.

5. Cycle life

5.1 Cycle life performance

5.1.1 The cell can be charged/discharged repeatedly up to times specified in the produce specification with a certain level of capacity also specified in the product specification.

5.1.2 Cycle life may be determined by conditions of charging, discharging, operating temperature and/or storage.

6. Design of System

6.1 Connection between the cell and the battery

6.1.1 The cell should not be soldered directly with leads. Namely, the cell should be welded with leads on its terminal and then be soldered with wire or leads to soldered lead.

6.1.2 Otherwise, it may cause damage of component, such as separator and insulator, by heat generation.

Spec. No.	ICR18650-26JM	Version No.	1.0
-----------	---------------	-------------	-----

6.2 Positioning the battery in the System

6.2.1 The battery should be positioned as possible as far from heat sources and high temperature components.

6.2.2 Otherwise, it may cause loss of characteristics.

6.3 Mechanical shock protection of the battery

6.3.1 The battery should equip with appropriate shock absorbers in order to minimize shock.

6.3.2 Otherwise, it may cause shape distortion, leakage, heat generation and/or rupture.

6.4 Short-circuit protection of the cell

6.4.1 The cell equips with an insulating sleeve to protect short-circuit which may occur during transportation, battery assembly and /or system operation.

6.4.2 If the cell sleeve is damaged by some cause such as outside impact, it may cause short-circuit with some wiring inside the battery.

6.5 Connection between the battery and charger/system

6.5.1 The battery should be designed to be connected only to the specified charger and system.

6.5.2 A reverse connection of the battery, even in the specified system, should be avoided by employing special battery design such as a special terminals.

7. Battery Pack Assembly

7.1 Prohibition of usage of damaged cell

7.1.1 The cell should be inspected visually before battery assembly.

7.1.2 The cell should not be used if sleeve-damage, can-distorsion and/or electrolyte-smell is detected.

7.2 Terminals handling

7.2.1 Excessive force on the negative terminal should be avoided when external lead is welded.

7.3 Transportation

7.3.1 If the cell is necessary to transported to order place, such as the battery manufacturer, careful precautions should be taken to avoid damage of cell.

8. Others

8.1 Disassembly

8.1.1 The cell should not be dismantled from the battery pack.

8.1.2 Internal short-circuit caused by disassembly may lead to heat generation and/or venting.

Spec. No.	ICR18650-26JM	Version No.	1.0
-----------	---------------	-------------	-----

8.1.3 When the electrolyte is coming in contact with the skin or eyes, flush immediately with fresh water and seek medical advice.

8.2 Short-circuiting

8.2.1 Short-circuit results in very high current which leads to heat generation.

8.2.3 An appropriate circuitry should be employed to protect accidental short-circuiting.

8.3 Incineration

8.3.1 Incinerating and disposing of the cell in fire are strictly prohibited, because it may cause rupture.

8.4 Immersion

8.4.1 Soaking the cell in water is strictly prohibited, because it may cause melt of components to damaged to functions.

8.5 Mixing use

8.5.1 Different types of cell, or same types but different manufacturer's cell may lead to cell rupture or damage to system due to the different characteristics of cell.

8.6 Battery exchange

8.6.1 Although the cell contains no environmentally hazardous component, such as lead or cadmium. the battery should be disposed according to the local regulations when it is disposed.

8.6.2 The cell should be disposed with a discharged state to avoid heat generation by an inadvertent short-circuit.

8.7 Caution - The Battery used in this device may present a risk of fire or chemical burn if mistreated. Do not disassemble, heat above 100 °C or incinerate. Replace battery with Samsung SDI battery only. Use of another battery may present a risk of fire or explosion. Dispose of used battery promptly. Keep away from children. Do not disassemble and do not dispose of in fire.

8.8 Warning – Attached

Spec. No.	ICR18650-26JM	Version No.	1.0
-----------	---------------	-------------	-----

▣ Pack Design Guideline (For electrical design)

Item		Portable IT	Power-Tool	Medical	E-Bike	E-Scooter	EV/LEV	ESS/UPS
<input type="checkbox"/>	Standard charging voltage (4.20V cell)	4.20V	4.20V	4.10V	4.10V	4.10V	4.10V	4.00V (4.05V)
<input type="checkbox"/>	Standard charging voltage (4.35V cell)	4.35V	4.35V	4.20V	4.20V	4.20V	4.20V	4.00V (4.05V)
<input type="checkbox"/>	Charging method	CC-CV	CC-CV	CC-CV	CC-CV	CC-CV	CC-CV	CC-CV
<input type="checkbox"/>	Full-charging cut-off current*	0.05C	0.05C	0.025C	0.025C	0.025C	0.025C	0.025C (Continuous)
<input type="checkbox"/>	Voltage of Re-charging (4.20V cell)	4.10V	4.10V	4.05V	4.05V	4.05V	4.05V	4.00V (4.05V)
<input type="checkbox"/>	Voltage of Re-charging (4.35V cell)	4.25V	4.25V	4.10V	4.10V	4.10V	4.10V	4.00V (4.05V)
LCO LMO	<input type="checkbox"/> Min. voltage of terminate discharging	3.00V	2.50V	3.00V	3.00V	3.00V	3.00V	3.00V
	<input type="checkbox"/> Min. voltage of over-discharging protection	2.50V	2.00V	2.50V	2.50V	2.50V	2.50V	2.50V
NCA NCM	<input type="checkbox"/> Min. voltage of terminate discharging	2.50V	2.50V	2.50V	2.50V	2.50V	2.50V	2.50V
	<input type="checkbox"/> Min. voltage of over-discharging protection	2.30V	2.00V	2.50V	2.50V	2.50V	2.50V	2.50V
<input type="checkbox"/>	BMS Shut Down Voltage**	2.00V	2.00V	2.00V	2.00V	2.00V	2.00V	2.00V
<input type="checkbox"/>	Max. consumption current of BMS after shut down	10μA/Cell	10μA/Cell	10μA/Cell	10μA/Cell	10μA/Cell	10μA/Cell	10μA/Cell
<input type="checkbox"/>	Do not charge***	↓ 1.00V	↓ 1.00V	↓ 1.00V	↓ 1.00V	↓ 1.00V	↓ 1.00V	↓ 1.00V
<input type="checkbox"/>	Pre-charging voltage range****	1.0V ~ 3.0V	1.0V ~ 3.0V	1.0V ~ 3.0V	1.0V ~ 3.0V	1.0V ~ 3.0V	1.0V ~ 3.0V	1.0V ~ 3.0V
<input type="checkbox"/>	Current range of Pre-charging	0.1C ~ 0.5C	0.1C ~ 0.5C	0.1C ~ 0.5C	0.1C ~ 0.5C	0.1C ~ 0.5C	0.1C ~ 0.5C	0.1C ~ 0.5C

Remark:

* Current of cell which full-charging shall be terminated.

** Voltage condition of BMS which shall be shut down.

*** Under 1.0V voltage, do not charge the cell.

**** Voltage range of cell which shall be charged by Pre-charging.

If a customer's battery pack cannot meet the requirements above, SDI cannot take responsibility for a quality issue about a battery cell.

Spec. No.	ICR18650-26JM	Version No.	1.0
-----------	---------------	-------------	-----

▣ Pack Design Guideline (For mechanical design)

Item	Portable IT	Power-Tool	Medical	E-Bike	E-Scooter	EV/LEV	ESS/UPS
<input type="checkbox"/> Need partitions(separator) between BMS and a Cell	◎	◎	◎	◎	◎	◎	◎
<input type="checkbox"/> Need to check if the pack is designed to be able to avoid thermal runaway (1KWh ↑)					◎	◎	◎
<input type="checkbox"/> Need to analyze the battery pack's thermal distribution and its effect on the pack's life cycle					◎	◎	◎
<input type="checkbox"/> Need to use a non-flammable (VO level) case	◎	◎	◎	◎	◎	◎	◎
<input type="checkbox"/> Need to apply improved material (Steel) to the case						◎	◎
<input type="checkbox"/> Need to analyze the battery pack's structure, system, installation status and use environment						◎	◎

If a customer's battery pack cannot meet the requirements above, SDI cannot take responsibility for a quality issue about a battery cell.

Spec. No.	ICR18650-26JM	Version No.	1.0
-----------	---------------	-------------	-----

Handling Precaution and Prohibitions of Lithium Ion & Lithium Ion Polymer Rechargeable Cells and Batteries

Inaccurate handling of lithium ion and lithium ion polymer rechargeable battery may cause leakage, heat, smoke, an explosion, or fire.

This could cause deterioration of performance or failure. Please be sure to follow instructions carefully.

1.1 Storage

Store the battery at low temperature (below 20°C is recommended), low humidity, no dust and no corrosive gas atmosphere.

1.2 Safety precaution and prohibitions

To assure product safety, describe the following precautions in the instruction manual of the application.

[Danger!]

■ Electrical misuseage

Use dedicated charger.

Use or charge the battery only in the dedicated application.

Don't charge the battery by an electric outlet directly or a cigarette lighter charger.

Don't charge the battery reversely.

■ Environmental misuseage

Don't leave the battery near the fire or a heated source.

Don't throw the battery into the fire.

Don't leave, charge or use the battery in a car or similar place where inside of temperature may be over 60°C.

Don't immerse, throw, wet the battery in water / seawater.

■ others

Don't fold the battery cased with laminated film such as pouch and Polymer.

Don't store the battery in a pocket or a bag together with metallic objects such as keys, necklaces, hairpins, coins, or screws.

Don't short circuit (+) and (-) terminals with metallic object intentionally.

Don't pierce the battery with a sharp object such as a needle, screw drivers.

Don't heat partial area of the battery with heated objects such as soldering iron.

Don't hit with heavy objects such as a hammer, weight.

Don't step on the battery and throw or drop the battery on the hard floor to avoid mechanical shock.

Don't disassemble the battery or modify the battery design including electric circuit.

Spec. No.	ICR18650-26JM	Version No.	1.0
-----------	---------------	-------------	-----

Don't solder on the battery directly.

Don't use seriously scared or deformed battery.

Don't put the battery into a microwave oven, dryer ,or high-pressure container.

Don't use or assemble the battery with other makers' batteries, different types and/or models of batteries such as dry batteries, nickel-metal hydride batteries, or nickel-cadmium batteries.

Don't use or assemble old and new batteries together.

[Warning!]

Stop charging the battery if charging isn't completed within the specified time.

Stop using the battery if the battery becomes abnormally hot, order, discoloration, deformation, or abnormal conditions is detected during use, charge, or storage.

Keep away from fire immediately when leakage or foul odors are detected. If liquid leaks onto your skin or cloths, wash well with fresh water immediately.

If liquid leaking from the battery gets into your eyes, don't rub your eyes and wash them with clean water and go to see a doctor immediately.

If the terminals of the battery become dirty, wipe with a dry cloth before using the battery.

The battery can be used within the following temperature ranges. Don't exceed these ranges.

Charge temperature ranges : 0℃ ~ 45℃

Discharge Temperature ranges : -20℃ ~ 60℃

Store the battery at temperature below 60℃

Cover terminals with proper insulating tape before disposal.

[Caution!]

■ Electrical misuseage

Battery must be charge with constant current-constant voltage (CC/CV).

Charge current must be controlled by specified value in Cell specification.

Cut-off Voltage of charging must be 4.2V.

Charger must stop charging battery by detecting either charging time or current specified in Cell's specification.

Discharge current must be controlled by specified value in Cell's specification.

Cut-off Voltage of discharging must be over 2.5V.

■ others

Keep the battery away from babies and children to avoid any accidents such as swallow.

If younger children use the battery, their guardians should explain the proper handling method and precaution before using.

Spec. No.	ICR18650-26JM	Version No.	1.0
-----------	---------------	-------------	-----

Before using the battery, be sure to read the user's manual and precaution of it's handling.

Before using charger, be sure to read the user's manual of the charger.

Before installing and removing the battery from application, be sure to read user's manual of the application.

Replace the battery when using time of battery becomes much shorter than usual.

Cover terminals with insulating tape before proper disposal.

If the battery is needed to be stored for an long period, battery should be removed from the application and stored in a place where humidity and temperature are low.

While the battery is charged, used and stored, keep it away from object materials with static electric chargers.

Safety Handling Procedure for the Transporter

- **Quarantine** : Packages that are crushed, punctured or torn open to reveal contents should not be transported. Such packages should be isolated until the shipper has been consulted, provided instructions and, if appropriate, arranged to have the product inspected and repacked.
- **Spilled Product** : In the event that damage to packaging results in the release of cells or batteries, the spilled products should be promptly collected and segregated and the shipper should be contacted for instructions.

Design of positioning the battery pack in application and charger

To prevent the deterioration of the battery performance caused by heat, battery shall be positioned away from the area where heat is generated in the application and the charger.

Design of the Battery Pack

Be sure adopting proper safe device such as PTC specified type or model in Cell Specification. If you intend to adopt different safety device which is not specified in Cell Specification, please contact Samsung SDI to investigate any potential safety problem.

Be sure designing 2nd protective devices such as PTC & PCM at the same time to protect Cell just in case one protective device is fault.

Please contact following offices when you need any help including safety concerns.

Spec. No.	ICR18650-26JM	Version No.	1.0
-----------	---------------	-------------	-----

Samsung SDI Emergency Contact Information

■ **Samsung SDI Headquarter.**

150-20, Gongse-ro, Giheung-gu, Yongin-si, Gyeonggi-do, Korea
Tel: +82-31-8006-3100, Fax : +82-31-210-7887

■ **Samsung SDI Cheonan factory.**

508, Sungsung-Dong, Cheonan City, Chungchongnam-Do, Korea
Tel:(+82)70-7125-1834 Fax:(+82)41-560-3697

■ **Samsung SDI America office.**

18600 Broadwick Street Rancho Dominguez CA 90220
Tel:(+1)310-900-5205 Fax:(+1)310-537-1033

■ **Samsung SDI Taiwan office.**

Rm. 3010, 30F., 333, Keelung Rd. Sec. 1, Taipei, Taiwan
Tel:(+886)2-2728-8469 Fax:(+886)2-2728-8480

■ **Samsung SDI Malaysia factory.**

Lot 635 & 660, Kawasan Perindustrian, Tuanku Jaafar, 71450
Sungai Gadut, Negeri Sembilan Darul Khusus, Malaysia
Tel: (+60)6-677-6160, 6153