

REVISION RECORD

REV	ECN	DESCRIPTION	DRFT	DATE
-----	-----	-------------	------	------

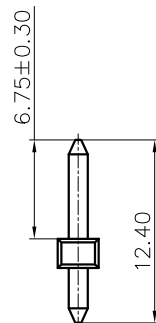
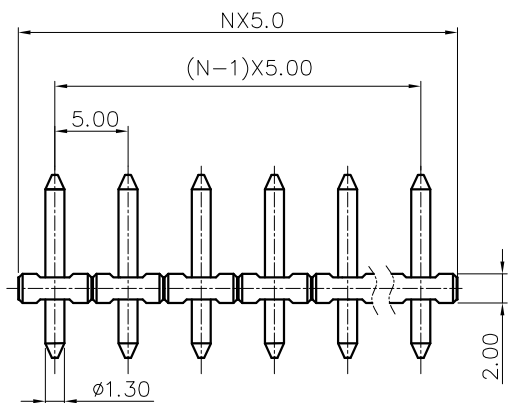

NOTES1:

UL Standard
1.Rated voltage/current : 300V / 10A

IEC Standard

1.Rated voltage/current : 250V / 12A

NOTES2:

- 1.Dimension shall be interpreted per ASME Y14.5-2009
- 2.Pitch : 5.0mm, Poles : N=2~24P
- 3.Withstanding voltage : AC2000V/1Min
- 4.Operating temperature: -40°C~+105°C
- 5.Undimensioned tolerances:

Pitch range in mm		Nominal dimension range in mm					—	∩	∇
TO	Over	Over	Over	Over	Over	0.1/10			
6	6 TO 10	10 TO 24	30 TO 30	30 TO 60	60 TO 100	100 TO 150	150	∠	
±0.15	±0.20	±0.30	±0.30	±0.50	±0.70	±1.00	±1.30	±2'	

6.RoHS Compliance

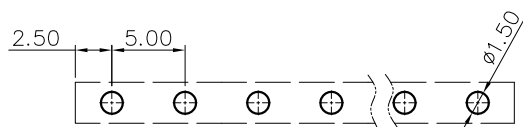
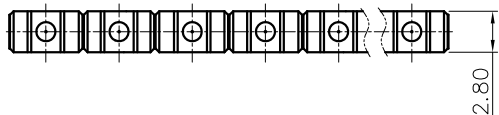
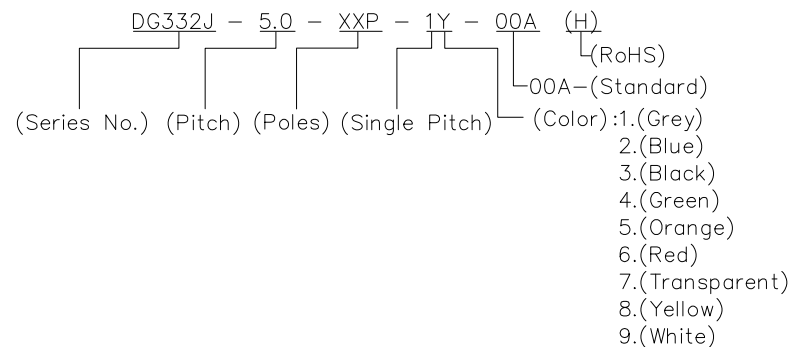

TOP VIEW-LAYOUT

DETACHED LISTS	PART NO.:	宁波高松电子有限公司 NINGBO DEGSON ELECTRICAL CO., LTD			
	APPD:	NAME: DG332J-5.0-XXP-1Y-00A(H)			
	CHKD:	TITLE: CUSTOMER DRAWING			
	DRFT:	DRAWING NO.:		REV	DO
 THIRD ANGLE PROJECTION		MM (INCH)	DO NOT SCALE DRAWING	SHEET	1/1
			SCALE	1:1	