



Part Number
Key Word



Site Search

[TOP](#)

[NEWS RELEASE](#)

[CONNECTOR SEARCH](#)

[CATALOG](#)



[SAMPLE](#)

[STOCK CHECK](#)

[TOP](#) > [FI-X30HL](#)

Product List

Product Name	FI-X30HL
Series Name	FI-X Series
Contact spacing (mm)	1
Number of Contacts	30
Connector type	Cable side Plug housing
PCB mounting type	-
PCB mounting method	-
Material of contact	-
Finish of contact in connecting area	-
Finish of contact in PCB mounting area	-
Material of housing	Heat resisting plastic (UL94V-0)
PCB side connector styles	-

PCB mounted height (mm)	-
Remarks	Without Pull-tab
Related Documents	 125Kbytes  333Kbytes
Pair	

Notice:

1. The values specified in this web site are only for reference. The products and their specifications are subject to change without notice. Contact our sales staff for further information before considering or ordering any of our products.
For purchase, a product specification must be agreed upon.
2. Users are requested to provide protection circuits and redundancy circuits to ensure safety of the equipment, and sufficiently review the suitability of JAE's products to the equipment.
3. The products presented in this web site are designed for the uses recommended below. We strongly suggest you contact our sales staff when considering use of any of the products in any other way than the recommended applications or for a specific use that requires an extremely high reliability.

(1) Applications that require consultation:

- (i) Please contact us if you are considering use involving a quality assurance program that you specify or that is peculiar to the industry, such as:
Automotive electrical components, train control, telecommunications devices (mainline), traffic light control, electric power, combustion control, fire prevention or security systems, disaster evention equipment, etc.

(ii) We may separately give you our support with a quality assurance program that you specify, when you think of a use such as :

Aviation or space equipment, submarine repeaters, nuclear power control systems, medical equipment for life support, etc.

(2) Recommended applications include:

Computers, office appliances, telecommunications devices (terminals, mobile units), measuring equipment, audiovisual equipment, home electric appliances, factory automation equipment, etc

SJ037012
(DRAWING NO.) 台架図

版数 REV.	年月日 DATE	DCN NO.	変更内容 DESCRIPTION	製図 DR.	担当 CHK.	査閲 APPD.	承認 APPD.
2	6.May.2003	52052	AN ERROR IN WRITING CORRECTION	T.YAMAJI	K.HISAMATU	A. Kimura	Y. Ichiyama

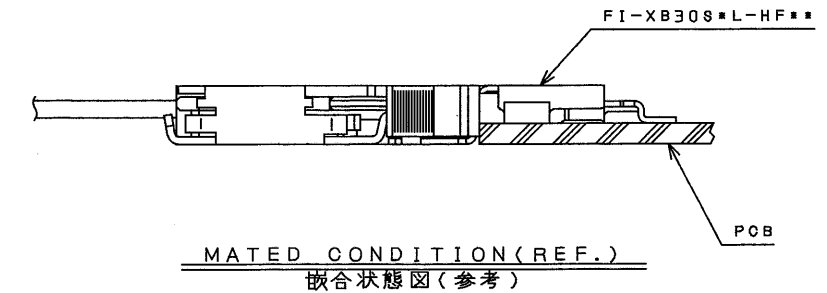
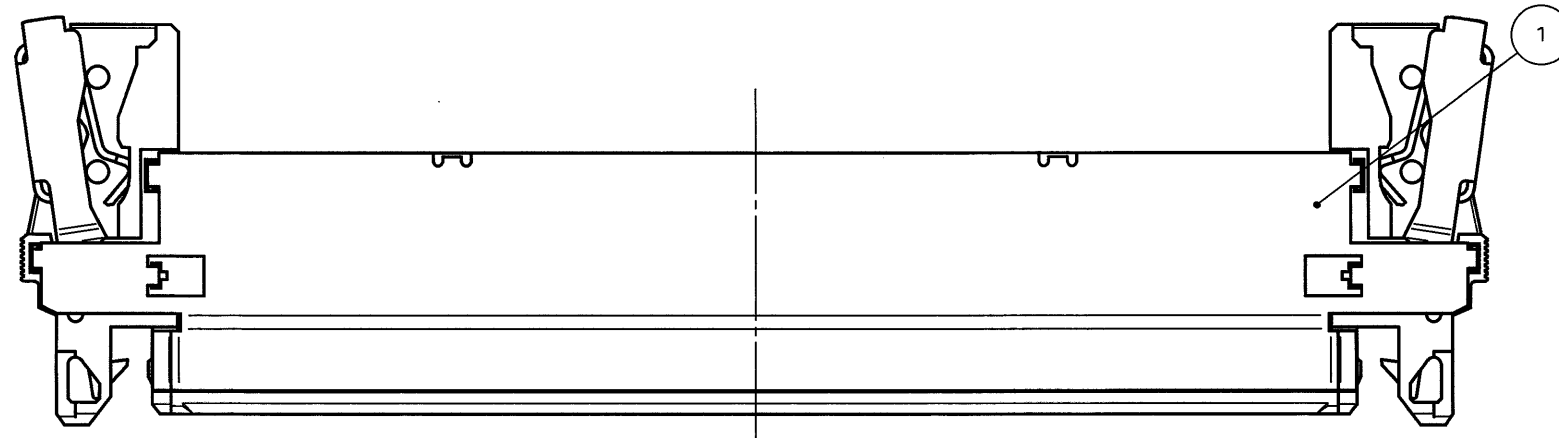
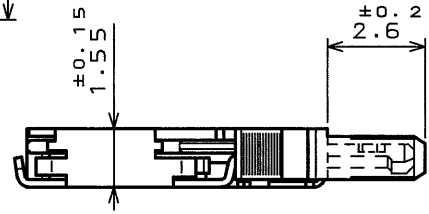
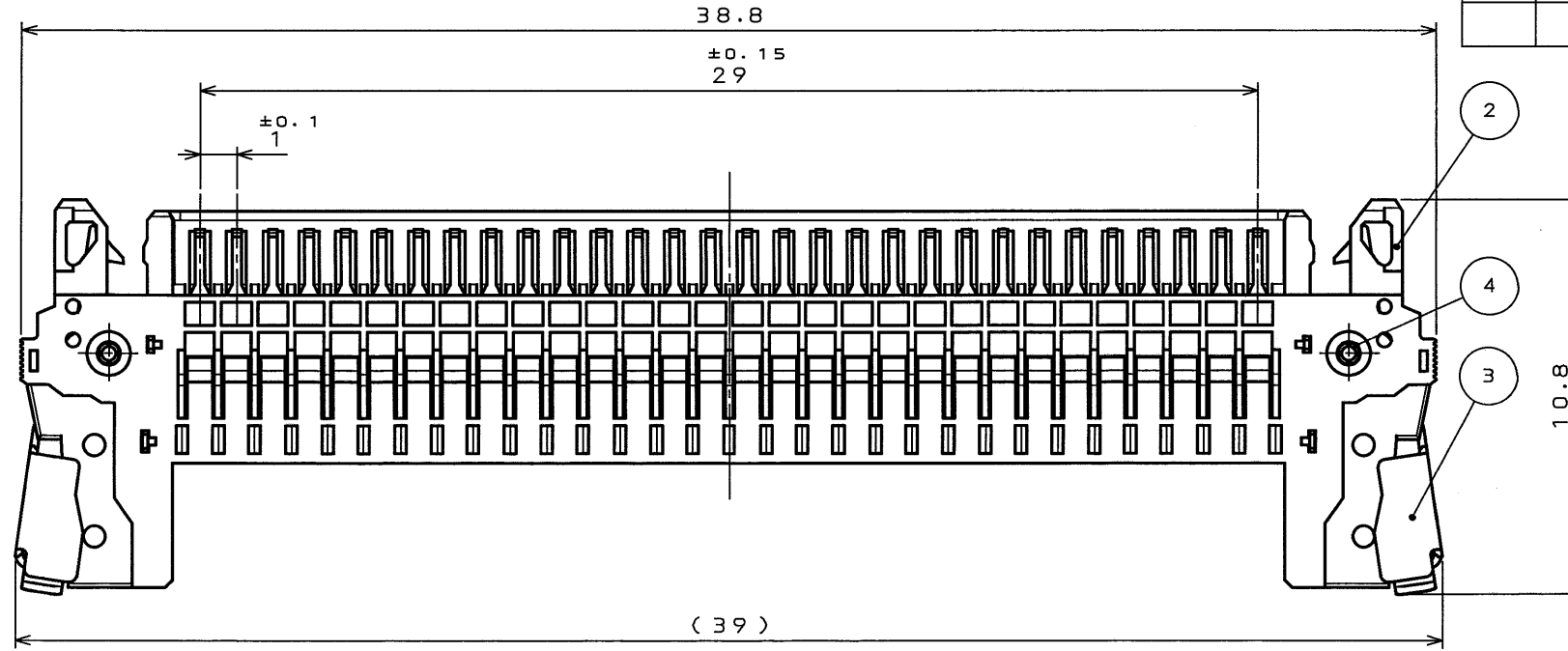

NOTE 1. Refer to Instruction manual JAHL-1597-20.
注 1. 取扱説明書 JAHL-1597-20 を参照してください。

NOTE 2. APPLICABLE CONTACT
FI-XC3-1-15000 (SJ033911) or FI-XC3-B-1-15000 (SJ036918)
注 2. 適合コンタクトは下記コンタクトを使用して下さい。
FI-XC3-1-15000 (SJ033911) 又は FI-XC3-B-1-15000 (SJ036918)

符号 NO.	名称 DESCRIPTION	個数 QTY.	材料 MATERIAL	仕上 FINISH	備考 REMARKS
4	PIVOT	2	STAINLESS STEEL		
3	LOCK LEVER	2	STAINLESS STEEL		
2	INSULATOR	1	HEAT RESISTING PLASTIC		UL94 V-0 BEIGE Δ
1	GROUND PLATE	1	COPPER ALLOY	TIN PLATING	

仕様書 (SPECIFICATION) JAGS-1597-20 JAHL-1597-20	第1版 (ORIGINAL DATE) 4.Sep.2002	尺 (SCALE) 5:1	シリーズ (SERIES) FI-X
公差 (GENERAL TOLERANCE) 寸法 (DIMENSION) 角度 (ANGLES)	製図 DR.	名称 (TITLE) FI-X30HL (HOUSING)	
. ±0.8 .X ±0.4 .XX ±0.1 .XXX ±	担当 CHK. 査閲 APPD. 承認 APPD.	重量 (WEIGHT)	
	K.HISAMATSU A.KIMURA Y.ICHIYAMA	JAPAN AVIATION ELECTRONICS INDUSTRY, LTD. 図面番号 (DRAWING NO.) SJ037012	

DOF-0-212D(98.02)



CDS-02-180-10245
SIZE A3
版数 (REV.) 2

JAPAN AVIATION ELECTRONICS IND., LTD. CONNECTOR DIVISION 日本航空電子工業株式会社 コネクタ事業部 THIS SPECIFICATION TABLE CANNOT BE REPRODUCED WITHOUT WRITTEN CONSENT OF JAE. この製品規格表は日本航空電子工業株式会社の 許可のない限り複写を禁じます。		SPECIFICATION TABLE 製品規格表		Connector Specification No. JACS-1597-0	
				Connector Series Name 品名 FI-X (B) D7S-HF**(PCB SIDE)	
				Applicable Drawing No. 製品図面 SJ033459 SJ033460	
				TK C	
Rev. 版数	Date 発行日	DCN No	Drawn by 担当	Checked by 査閲	Approved by 承認
1	7.Jan.1999	-	K Hayashi	Hisatomi	Amemiya
2	27.Jan.2003	51411	Takaku,	A. Kimura	<i>Y. Ohizome</i>
Standard data 定格					
Applicable connector 適合コネクタ		Connector: FI-XD7M, Drawing number: SJ033463			
Applicable wire 適合電線		FPC of which connecting area is 0.14 \pm 0.03 mm thick. (Note *2) 接触部 t0.14 \pm 0.03 FPC(2)			
Rated current 電流		1A per contact AC,DC 各 1A/1 端子当り			
Rated voltage 電圧		200V AC, DC AC,DC200V			
Operating temperature range 使用温度範囲		-40 °C to + 80 °C			
Note 備考 1: This specification covers the requirements for PCB side connector, the counterpart FPC SIDE connector and applicable FPC. 2: If the end hemispheric probe (tip R: 0.2) is applied to the FPC connecting area with 1.96N , the thickness of the connecting area should be within tolerance. 1: 本コネクタ規格は適合 PCB SIDE コネクタと適合 FPC SIDE(FPC 中継)コネクタ及び適合 FPC を嵌合させた状態での性能を規定する 2: FPC の接触部に先端半球状プローブ(先端R=0.2)を 1.96N の荷重で加えた時、接触部の厚さは公差内である事					
Item		Procedure 試験方法		Requirement 規定	
MECHANICAL 機械的性能					
Material & finish 材料仕上加工法		Visual, dimensional and functional inspection.		Meets requirements of product drawing. 図面と相違のないこと	
Connector mating force 総合挿入力		Measure force necessary to mate between the counterpart connectors. 適合コネクタ間にて挿入を行う。		39.2N(Max.) 39.2N 以下	
Connector unmating force 総合抜去力		Measure force necessary to unmate between the counterpart connectors. 適合コネクタ間にて抜去を行う。		4.9N(Min.) 4.9N 以上	
Slider operating force スライダ操作力		Tuck the slider after applicable FPC is inserted. 適合 FPC を挿入後、スライダを押し込む		39.2N(Max.) 39.2N 以下	
Cable retention ケーブル保持力		Measure the FPC retention after tucking the slider after applicable FPC. 適合 FPC を挿入、スライダを押し込んだ後、FPC 保持力を測定		14.7N(Min.) 14.7N 以上	

Item	Procedure 試験方法	Requirement 規定
Vibration 耐振性	Subject specimens to 10-55 Hz at 1.5mm amplitude, 2hours in each of 3axes, 6hours in total 全振巾 1.5mm 10~55Hz 各 2h 計 3 軸 6h	No electrical discontinuity more than 1 μ S. No damage. 1 μ S 以上の電流の遮断がないこと。 部品に機械的欠陥の無いこと。
Shock 耐衝撃性	Applying an appropriate holder is allowed in Vibration test and Shock test. MIL-STD-202, METHOD 202, 490m/s ² , 3axes 振動及び衝撃試験においては取付けに適当なホルダーを使用してもよい。	
Durability 寿命試験	Mate and unmate the connectors for 50 cycles. 50 回の挿抜を行う。	Contact resistance: 80m Ω (Max.) 接触抵抗: 80m Ω 以下
Contact retention コンタクト保持力	Measure the contact retention with Tensile strength tester. 引張試験機にてコンタクト保持力を測定。	2.9 N (Min.) 2.9 N 以上
ELECTRICAL 電気的性能		
Voltage proof 耐電圧	Apply the specified voltage between adjacent contacts. 近接コンタクト間に規定電圧を印加	500V AC r.m.s. No breakdown caused for 1 minute. AC500Vr.m.s. 1 分間異常のないこと。
Insulation resistance 絶縁抵抗	Apply 100V DC between adjacent contacts and measure its resistance within 1 minute. 近接コンタクト間に 100V DC を印加、1 分以内で測定	100M Ω (Min.) 100M Ω 以上
Contact resistance 接触抵抗	Measure it with low voltage less than 20mV and 1mA. 低レベル 20mV 以下、1mA 以下で測定	40m Ω (Max.) 40m Ω 以下
ENVIRONMENTAL 環境的性能		
Rapid change of temperature 熱衝撃	Subject specimens to continuous 5 cycles between -55 $^{\circ}$ C and +85 $^{\circ}$ C for 30minutes each. 熱衝撃試験 -55 $^{\circ}$ C ~ +85 $^{\circ}$ C (各 30 分) 連続 5 サイクル	Insulation resistance: 50M Ω (Min.) Voltage proof: 250V r.m.s. 1 minute No breakdown. Contact resistance: 80m Ω (Max.) 絶縁抵抗 50M Ω 以上 耐電圧 250Vr.m.s. 1 分間異常のないこと 接触抵抗 80m Ω 以下
Damp heat, steady state 耐湿性	Subject specimens to 90-95% RH at 60 $^{\circ}$ C for 96 hours. 湿度試験 60 $^{\circ}$ C, 90~95%RH, 96h	
Corrosion, salt mist 耐腐食性	Subject specimens to 5% salt concentration at 35 $^{\circ}$ C for 48 hours. 塩水噴霧試験 塩水濃度: 5%, 35 $^{\circ}$ C, 48h	There should be no corrosion detrimental to contact connection. Contact resistance: 80m Ω (Max.) コンタクトの接触上有害な腐食が生じないこと。 接触抵抗: 80m Ω 以下
Resistance to soldering heat, solder bath method 半田耐熱性	Leave specimens in the 260 \pm 5 $^{\circ}$ C chamber for 2minutes. 260 \pm 5 $^{\circ}$ C の恒温槽に 2 分間放置	No damage. 外観等、異常の無いこと
Solderability 半田付け性	After dipping in the flux for 5 to 10 seconds, dip in Sn:Pb=60:40 solder of 230 \pm 5 $^{\circ}$ C for 3 \pm 0.5 seconds. 適合フラックスに 5~10s 浸漬し Sn:Pb=60:40 半田 230 \pm 5 $^{\circ}$ C に 3 \pm 0.5s 浸漬する	Wet Solder Coverage: 95%(Min.) 浸した部分の 95%以上が半田で覆われていること

Handling Care

A. About Mating Connectors

1. The connectors should be mated / unmated each other in parallel way.

取扱注意事項

A. コネクタ同士の嵌合について

1. 通常の取扱は、コネクタ本体を手で持って、相手側コネクタと平行に、かつ水平に挿入、抜去して下さい。

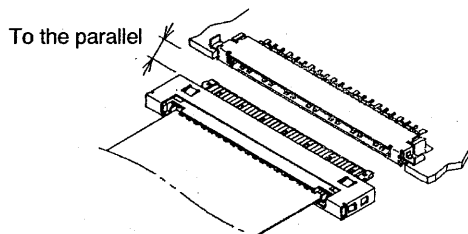

2. Mating

Do not insert a connector to a counterpart connector if there is a gap (A) shown above in the other side as they are being mated.

Confirm that the plug and the receptacle are guided to each other.

The plug should be inserted with 5° (Max.) diagonally to the width direction.

2. 挿入(入れる時)

片側が嵌合し始めた時に、反対側にスキマ A がある状態のまま挿入しないで下さい。両側のガイドが相手側に案内された状態で平行に挿入して下さい。上下方向の挿入は 5° 以内の範囲で挿入して下さい。(ガイドのガタ分程度)

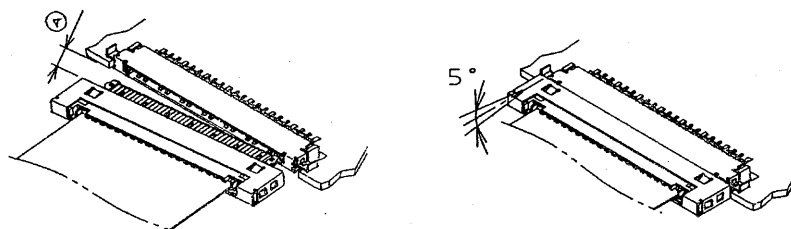

3. Unmating

Pull out a cable side connector in parallel to a counterpart connector.

Do not hold and turn neither sides of the base nor the cable to unmate the connectors as shown in the figure.

3. 抜去(抜く時)

図の様にコネクタの片端を持って回転させる様に抜かないで下さい。相手側コネクタを平行に、かつ水平に抜去して下さい。

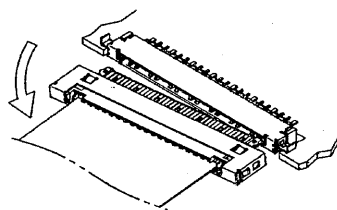

4. Do not bend the the PC board in directions shown in the figure.

4. 絶対にしないで下さい

図に示されているような方向に力を入れてコネクタを倒すような取り扱い及び、使用状態にしないでください。

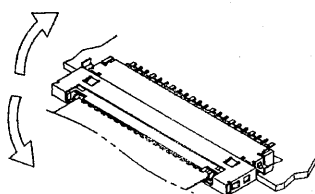

5. FPC

Do not bend FPC with connector a fulcrum as wires are connected. It may cause damages for FPC patterns.

5. FPC の取扱

FPC をコネクタを支点にして折り曲げる等の無理な配線及び取り扱いは FPC のパターン切れ等の破損の原因になりやすいのでご注意ください。

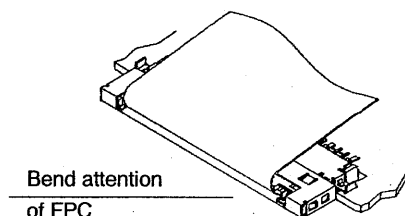

6. Soldering by soldering Iron (PCB Side)

Soldering and modifying by soldering iron should be done within 3 seconds. (Iron tip temperature of 350°C max., 30W)

6. 半田ゴテによる半田付け(PCB SIDE)

半田ゴテによる半田付け、修正は 3 秒以内に処理して下さい。(コテ先温度 30W 350°C以下)

B.About FPC side (FPC transit) connector

1. Input FPC

Confirm that the signal side and the ground side are matched with the direction of the connector.

Hold the end of a long side of the connector. Slide the FPC into the connector diagonally until the tip of the FPC touches the bottom.

B. FPC SIDE(FPC 中継)コネクタの取り扱い

1.FPC の挿入について

FPC のシグナル面とグランド面がコネクタのその方向と合っているか確認してください。

コネクタは長手方向の端を待ち、FPC は斜めからすべりこませ先端が奥に突き当たるまで軽く挿入してください。

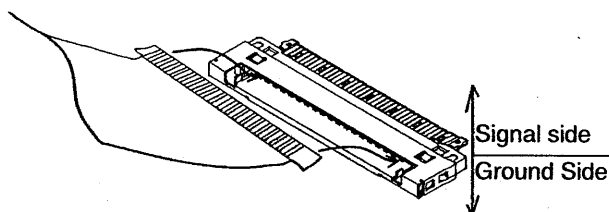

2. Tucking Shell

Confirm that FPC is fixed in right place. Tuck the shell lightly with a tweezers. Make sure there is no space as shown in the figure. If there is a space push the shell again.

2.シェルの挿入について

FPC が出てきていないことを確認し、ピンセット等で軽く押し込んでください。挿入後、隙間のないことを確認してください。(隙間のある場合は更に軽く押し込んでください。)

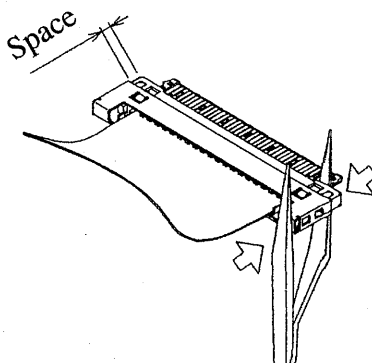

3. After mating Shell

Do not put unnecessary stress between the connector and FPC, especially on the border of connector ends.
(It may cause damages to FPC pattern and others.)

3. 嵌合後(シェル挿入後)の取り扱い

FPC とコネクタとの間(特にコネクタ端部との境界線)に無理な力をかけないでください。
(FPC パターン切れ、その他の破損の原因となります。)

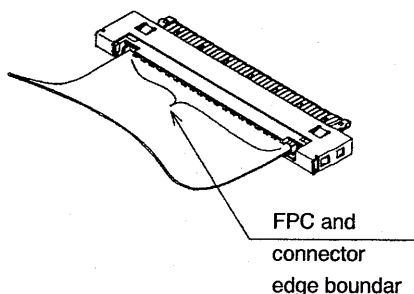

4. Removing FPC

Insert the screwdriver (1.2mm diameter) to the hole for unlocking till its tip reached the end. (*1)
Pull out the shell as keeping the state in *1. (*2)
After removing the shell, pull up FPC diagonally and take it off from the connector.

4.FPC のとりはずしについて

ロック解除のための穴に 1.2mm のドライバーを突き当たるまで差込み(*1)
その状態を保ちながらシェルを引き出してください。(*2)
シェル引き上げ後、FPC を斜めに引き上げて取り外してください。

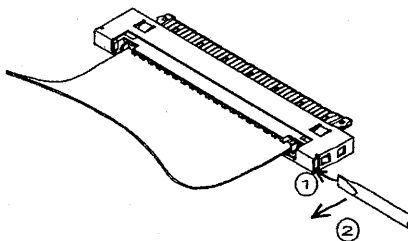

Do not re-use the connector.

As for FPC, It is allowed to use once again if there is no damage found.

See JAHL-1597 for details.

取り外されたコネクタの再使用は不可とします。

取り外したFPCは外観の異常のないこと(嵌合部付近の破損及び導体面のはがれ等)を確認し1回まで使用可能です。
以上、取り扱い注意事項の詳しい内容は JAHL-1597 をご覧ください。