

SHP Series



- Rugged Industrial Construction
- Variable Fan Speed for Noise Reduction
- -40 °C to +70 °C Operation
- AC OK, Remote On/Off and Active Current Share
- 5 V Standby
- Screw Terminals
- 3 Year Warranty

Specification

Input

Input Voltage	• 650 W: 80-264 VAC, derate output power 10% <90 VAC, and 20% <85 VAC 350 & 1000 W: 85-264 VAC, derate output power 10% <90 VAC
Input Frequency	• 47-63 Hz
Input Current	• 350 W: 3.8 A typical at 115 VAC, 2.1 A typical at 230 VAC, 650 W: 6.5 A typical at 115 VAC, 3.2 A typical at 230 VAC, 1000 W: 10.9 A typical at 115 VAC, 5.1 A typical at 230 VAC
Inrush Current	• 650 W: 40 A max at 264 VAC 350 & 1000 W: 60 A max at 264 VAC
Power Factor	• >0.9
Earth Leakage Current	• 0.5 mA max 264 VAC/60 Hz ⁽¹⁾
Input Protection	• 350W: T10 A/250 V, 650W: T16 A/250 V, 1000W: T20 A/250 V internal fuse in line and neutral, 350W: single internal fuse in line.

Output

Output Voltage	• 12-48 VDC (see tables)
Output Voltage Trim	• ±10% V1
Initial Set Accuracy	• 650 W: ±1% V1, ±5% V3, 350 & 1000 W: ±1% V1, ±5% V2
Minimum Load	• No minimum load required
Start Up Delay	• 500 ms max
Start Up Rise Time	• 50 ms typical
Hold Up Time	• 20 ms minimum
Drift	• ±0.2% after 20 min warm up
Line Regulation	• ±0.5%
Load Regulation	• 650 W: ±1% V1, ±5% V3, 350 & 1000 W: ±1% V1, ±5% V2
Transient Response	• 4% max. deviation, recovery to within 1% in 500 μs for a 50-75-50% load change
Ripple & Noise	• 1% pk-pk typical V1, 20 MHz bandwidth
Overvoltage Protection	• 115-145% Vnom, recycle input to reset
Overload Protection	• 110-140%, V1 only
Overtemperature Protection	• Auto reset
Short Circuit Protection	• Constant current characteristic ⁽¹⁾
Temp. Coefficient	• 0.05% / °C
Remote Sense	• Compensates for 0.5 V total voltage drop
Remote On/Off	• Uncommitted isolated optocoupler diode, powered diode inhibits V1 and fan supply ⁽¹⁾
Current Share	• Single wire current share ⁽¹⁾

General

Efficiency	• 85% typical
Isolation	• 3000 VAC input to output, 1500 VAC input to ground, 500 VDC output to ground
Switching Frequency	• PFC 70 kHz, main converter 200 kHz, standby 130 kHz typical
Power Density	• 350 W: 6.6 W/in ³ , 650 W: 8.2 W/in ³ , 1000 W: 8.9 W/in ³
Signals	• AC OK, remote on/off, current share ⁽¹⁾
MTBF	• 216-275 KHrs to MIL-HDBK-217F at 25 °C, GB ⁽¹⁾

Environmental

Operating Temperature	• -20 °C to +70 °C, derate linearly from +50 °C at 2.5% / °C to 50% at +70 °C, -40 °C start up ⁽¹⁾
Cooling	• 650 W: Forced cooled, '-TF' & '-EF' models have integral dual voltage level fan, which is load dependant, U Channel requires 5.5 m/s minimum airflow, 350 & 1000 W: Forced cooled via integral multi voltage level fan which is load dependant ⁽¹⁾
Operating Humidity	• 95% RH, non-condensing
Storage Temperature	• -40 °C to +85 °C
Operating Altitude	• 3000 m
Shock	• 30 g pk, half sine, 6 axes EN60068-2-27, -2-47
Vibration	• 2 g rms, 5-500 kHz, 3 axes EN60068-2-6

EMC & Safety

Emissions	• EN55032 class B conducted EN55032 class A radiated
Harmonic Currents	• EN61000-3-2 class A, 650 W: class C for loads ≥20% 350 & 1000 W: class C for loads ≥10%
Voltage Flicker	• EN61000-3-3
ESD Immunity	• EN61000-4-2, level 3 contact, level 3 air, Perf Criteria A
Radiated Immunity	• EN61000-4-3, level 3 Perf Criteria A
EFT/Burst	• EN61000-4-4, level 3 Perf Criteria A
Surge	• EN61000-4-5, installation class 3, Perf Criteria A
Conducted Immunity	• EN61000-4-6, level 3, Perf Criteria A
Dips & Interruptions	• EN61000-4-11, 30% 10 ms, 60% 100 ms, 100% 5000 ms, Perf Criteria A, B, B
Safety Approvals	• IEC60950-1:2005 Ed 2 / IEC62368-1:2014 UL 62368-1 & CAN/CSA C22.2 No. 62368-1-14, EN62368-1:2014/A11:2017, SEMI F47, CE & UKCA meets all applicable directives & legislation.

⁽¹⁾ See longform datasheet for more information

Output Voltage V1	Output Current V1	Standby Supply V2	Output Power		Model Number
			Continuous	Peak	
12 V	26.5 A	5 V / 0.2 A	318 W		SHP350PS12
15 V	22.0 A	5 V / 0.2 A	330 W		SHP350PS15
24 V	14.5 A	5 V / 0.2 A	348 W	417 W	SHP350PS24
28 V	12.5 A	5 V / 0.2 A	350 W	420 W	SHP350PS28
36 V	9.7 A	5 V / 0.2 A	350 W	420 W	SHP350PS36
48 V	7.3 A	5 V / 0.2 A	350 W	420 W	SHP350PS48

Notes

1. Peak power available for 10 seconds with 35% duty cycle.

Mechanical Details

End Fan

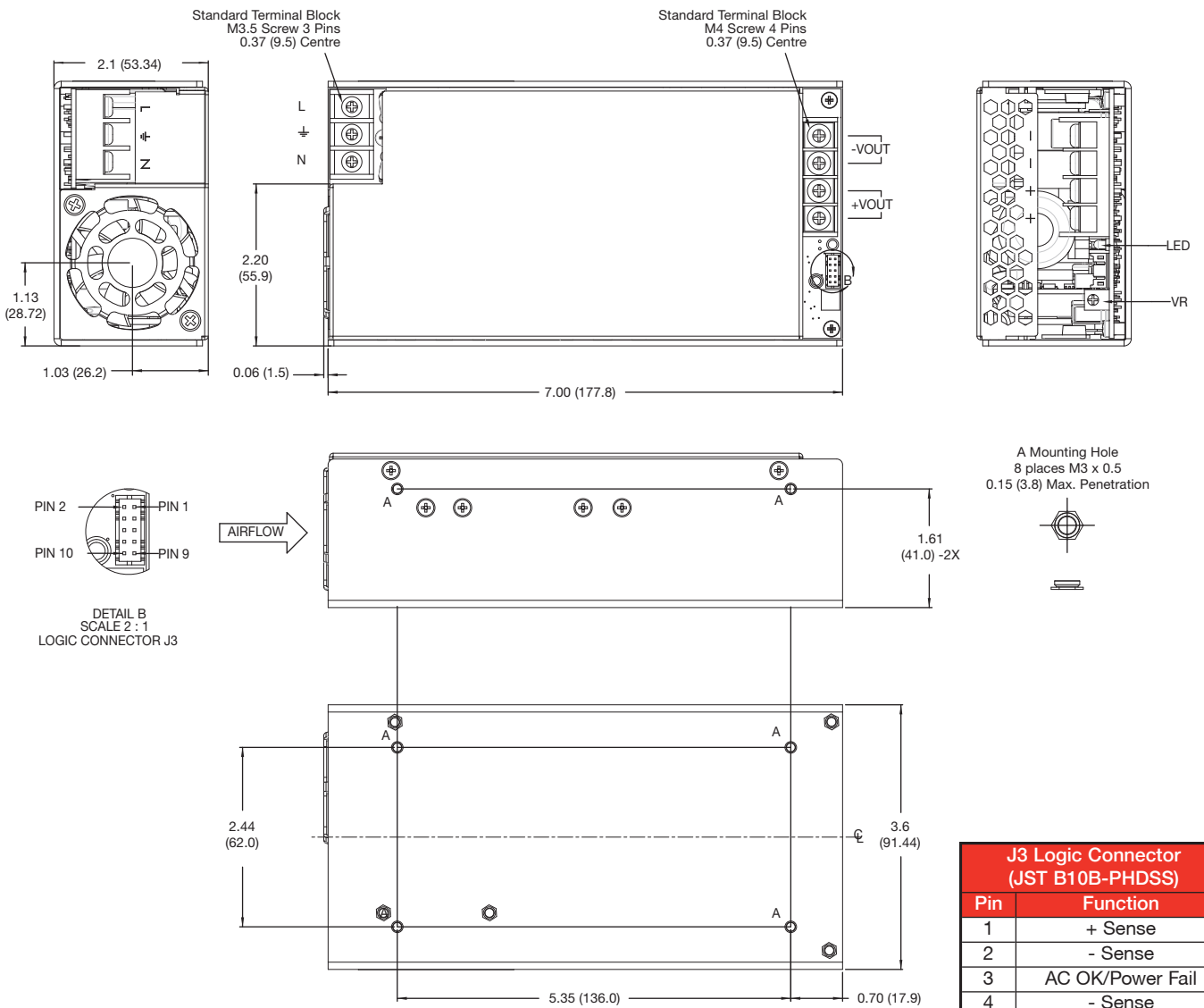

J3 Logic Connector (JST B10B-PHDSS)	
Pin	Function
1	+ Sense
2	- Sense
3	AC OK/Power Fail
4	- Sense
5	Current Share
6	Current Share
7	+ Inhibit
8	- Inhibit
9	+5 V Standby
10	5V Standby Return

Notes

1. Dimensions shown in inches (mm).
2. Weight: 1.73 lb (0.788 kg).

3. Logic connector J3 mates with JST housing PHDR-10VS and SPHD-001T-P0.5 Crimp Terminals

Models and Ratings

Output Voltage V1	Output Current V1	Fan Supply V2 ⁽⁴⁾	Standby Supply V3	Output Power ⁽³⁾	Model Number ^(1,2)
12 V	50.0 A	12 V / 0.5 A	5 V / 0.2 A	607 W	SHP650PS12-EF
15 V	40.0 A	12 V / 0.5 A	5 V / 0.2 A	607 W	SHP650PS15-EF
24 V	27.0 A	12 V / 0.5 A	5 V / 0.2 A	655 W	SHP650PS24-EF
28 V	23.0 A	12 V / 0.5 A	5 V / 0.2 A	655 W	SHP650PS28-EF
36 V	18.0 A	12 V / 0.5 A	5 V / 0.2 A	655 W	SHP650PS36-EF
48 V	13.5 A	12 V / 0.5 A	5 V / 0.2 A	655 W	SHP650PS48-EF

Notes

1. For top fan version replace '-EF' in model number with '-TF', e.g. SHP650PS12-TF
2. For U Channel version remove suffix.

3. U Channel models require a minimum of 5.5 m/s airflow from the system.
4. Not available for '-TF' and '-EF' models as used by integral fan.

Mechanical Details

End Fan (See Longform Datasheet for U-Channel Version)

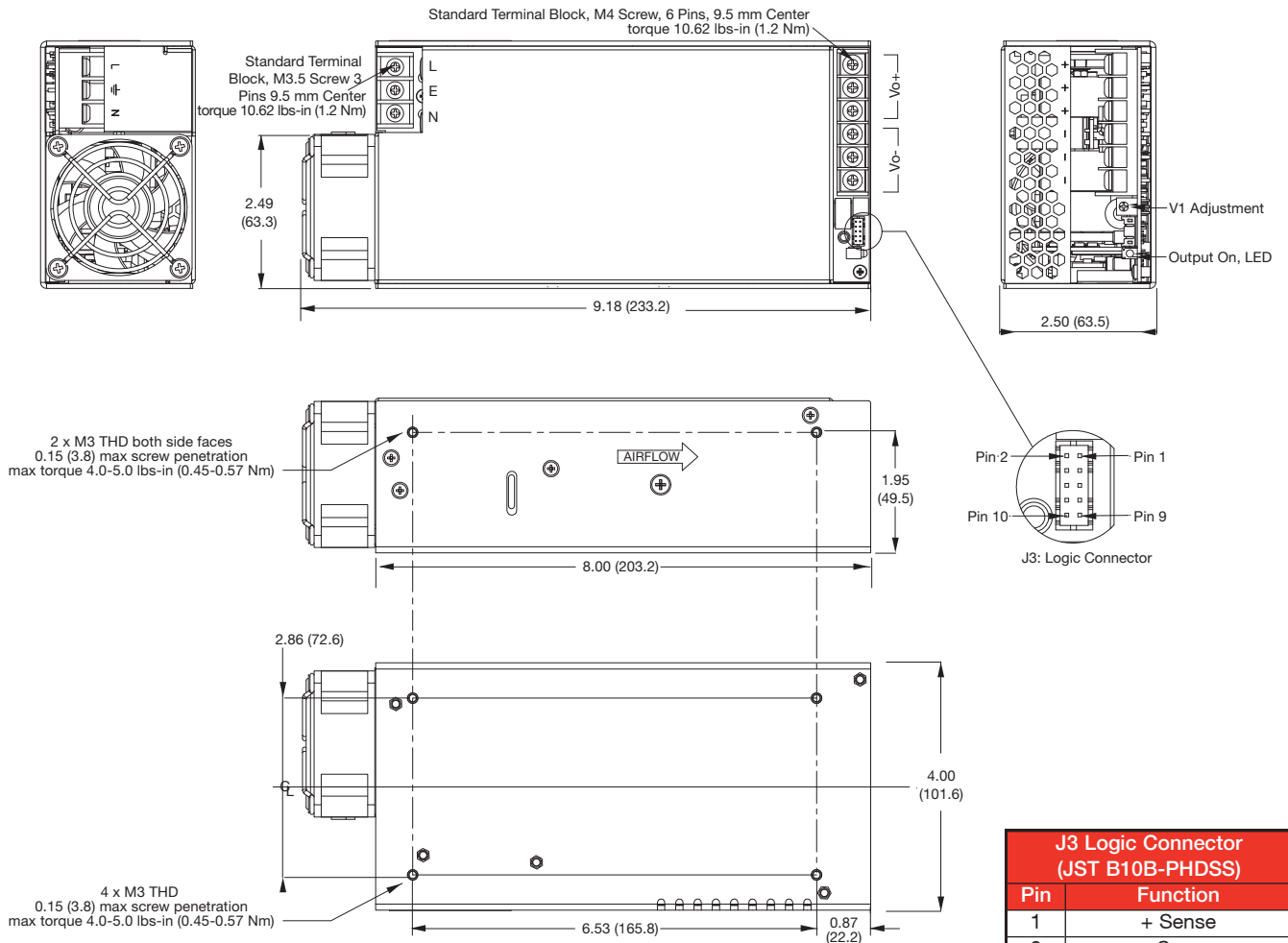

J3 Logic Connector (JST B10B-PHDSS)	
Pin	Function
1	+ Sense
2	- Sense
3	AC OK/Power Fail
4	- Sense
5	Current Share
6	Current Share
7	+ Inhibit
8	- Inhibit
9	+5V Standby (V3)
10	5V Standby Return (V3)

Notes

1. Dimensions shown in inches (mm).
2. Weight: 2.8 lb (1.27 kg).

3. J3 Mating Plug: JST part no. PHR-2, contact: JST part no. SPH-002T-P0.5S; J3 Mating Plug: JST part no. PHDR-10VS, contact: 26-22AWG JST part no. SPHD-001T-P0.5

Mechanical Details

Top Fan (Suffix -TF)

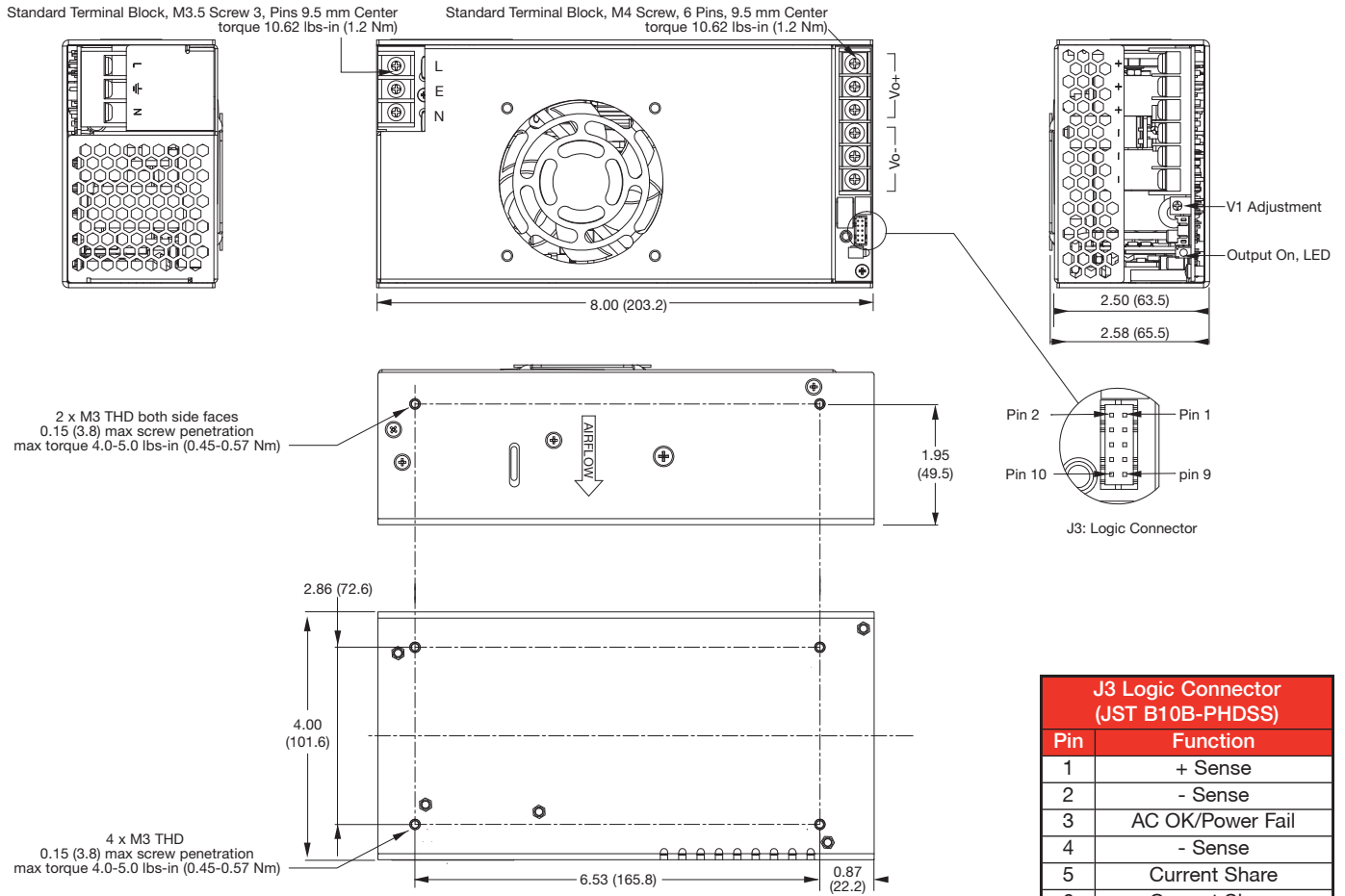

J3 Logic Connector (JST B10B-PHDSS)	
Pin	Function
1	+ Sense
2	- Sense
3	AC OK/Power Fail
4	- Sense
5	Current Share
6	Current Share
7	+ Inhibit
8	- Inhibit
9	+5V Standby (V3)
10	5V Standby Return (V3)

Notes

- Dimensions shown in inches (mm).
- Weight: 2.8 lb (1.27 kg).
- J3 Mating plug: JST part no. PHDR-10VS, contact: 26-22 AWG JST part no. SPHD-001T-P0.5.

Signals

AC OK/Power Fail

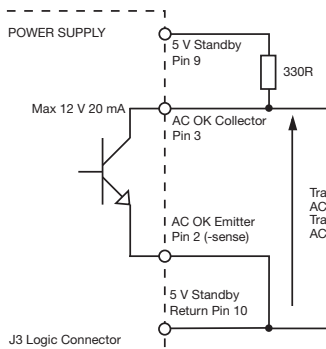

Remote On/Off (Inhibit)

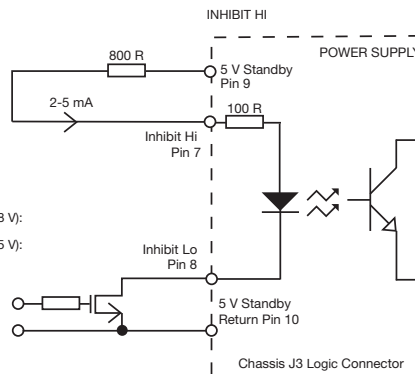

Signal High: Power Supply OFF
Low or Floating: Power Supply ON

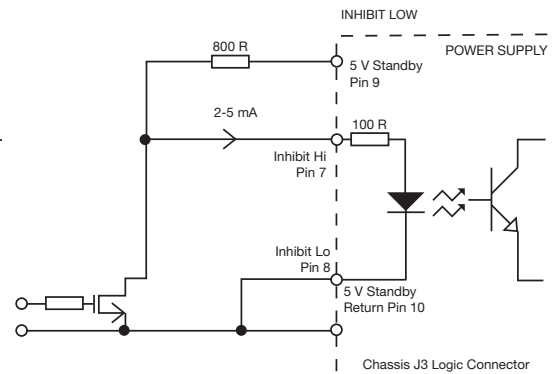

Signal High: Power Supply ON
Low or Floating: Power Supply OFF

For U Channel and Thermal Considerations please see longform datasheet.

Models and Ratings

SHP1000 XP

Output Voltage V1	Output Current V1		Standby Supply V2	Output Power		Model Number
	<180 VAC	>180 VAC		<180 VAC	>180 VAC	
12 V	83.0 A		5 V / 1.0 A	1000 W		SHP1000PS12
15 V	67.0 A		5 V / 1.0 A	1010 W		SHP1000PS15
24 V	42.0 A	50.0 A	5 V / 1.0 A	1013 W	1200 W	SHP1000PS24
28 V	36.0 A	43.0 A	5 V / 1.0 A	1013 W	1200 W	SHP1000PS28
36 V	28.0 A	34.0 A	5 V / 1.0 A	1013 W	1200 W	SHP1000PS36
48 V	21.0 A	25.0 A	5 V / 1.0 A	1013 W	1200 W	SHP1000PS48

Mechanical Details

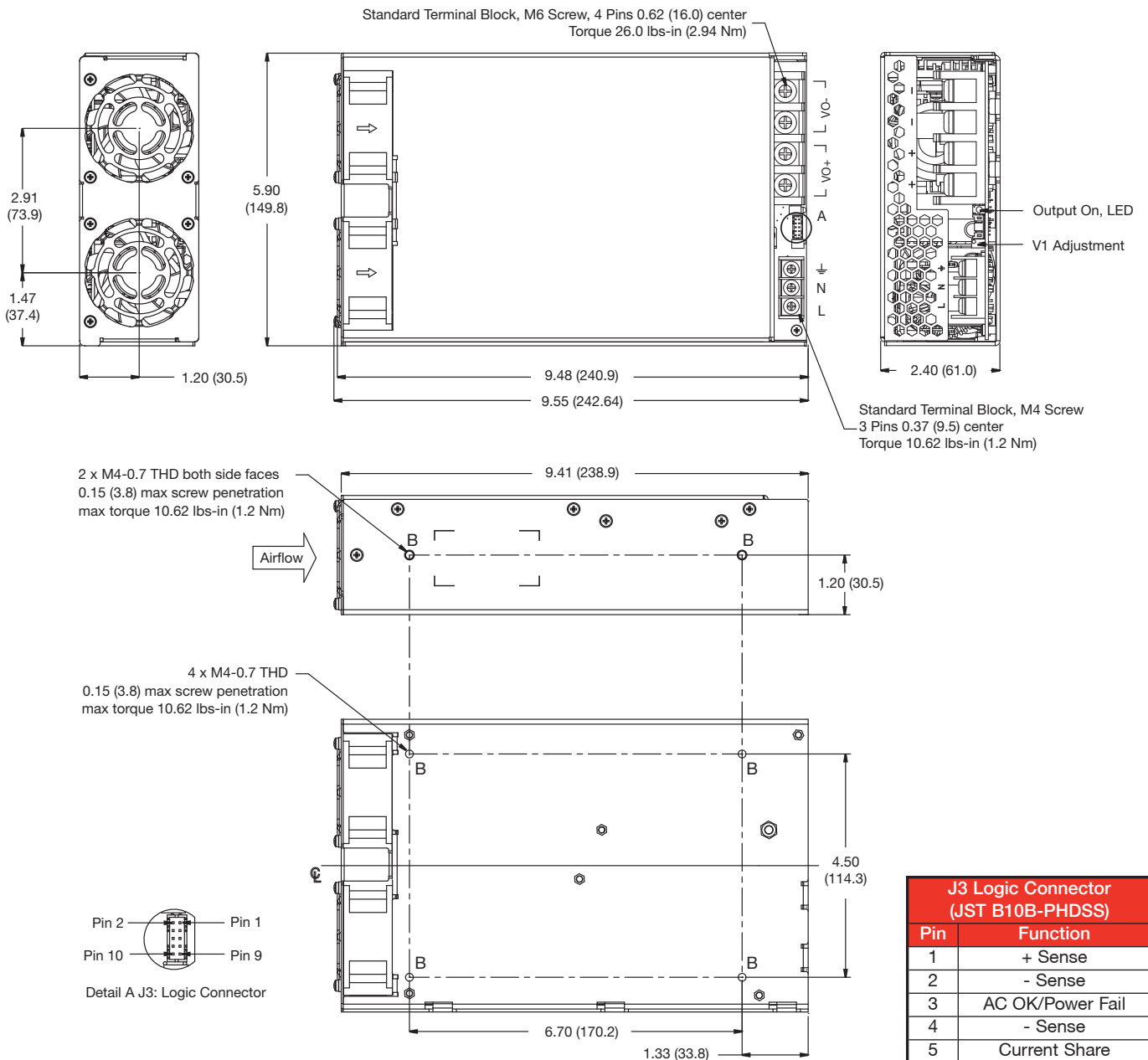

J3 Logic Connector (JST B10B-PHDS)	
Pin	Function
1	+ Sense
2	- Sense
3	AC OK/Power Fail
4	- Sense
5	Current Share
6	Current Share
7	+ Inhibit
8	- Inhibit
9	+5V Standby
10	-5V Standby

Notes

- Dimensions shown in inches (mm).
- Weight: 4.6 lb (2.08 kg)

- J3 Mating Plug: JST part no. PHDR-10VS, contact: 26-22AWG JST part no. SPHD-001T-P0.5