

标注公差/General tolerance(mm)													
0	>3	>6	>10	>18	>30	>50	>80	>120	>180	>250	>315	>400	0.1/1.0
~	~	~	~	~	~	~	~	~	~	~	~	~	~
3	6	10	18	30	50	80	120	180	250	315	400	500	~
±0.12/±0.18/±0.22/±0.26/±0.31/±0.37/±0.57/±0.80/±0.93/±1.05/±1.15/±1.60/±2.20/±2.50													
±2'													

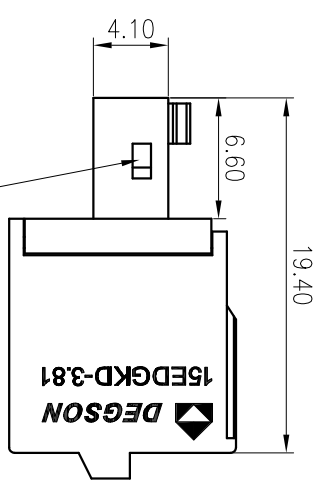

2-6P with card point
7-24P without card point

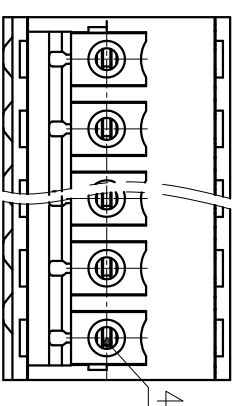
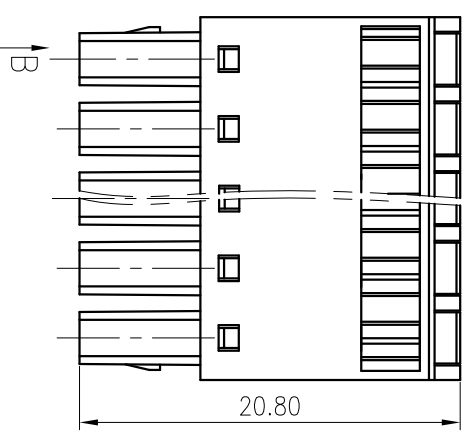
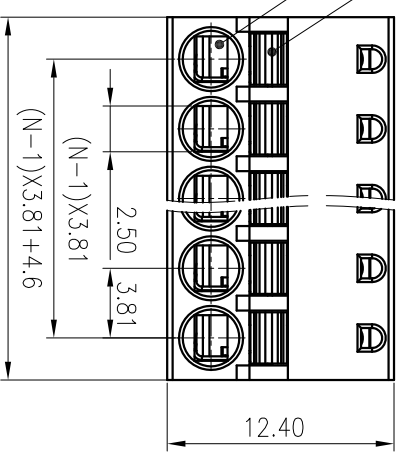
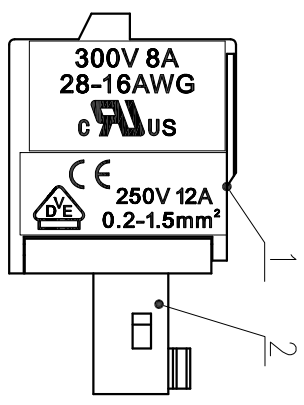

5	Spring	Stainless steel	
4	Clamp	Copper alloy	
3	Button	POM	
2	Cover	PA66	
1	Housing	PA66	
ITEM	NAME OF PART	MATERIAL	NOTES
UL 标准/UL Standard: B C D			
额定电压/电流/Rated Voltage(V)/Current(A) 300/8 300/8 300/8			
EC 标准/IEC Standard: III/3 III/2 II/3			
过压类别/Overvoltage Category/污染等 III/3 III/2 II/3			
线/Pollution Degree III/3 III/2 II/3			
额定电压/电流/Rated Voltage(V)/Current(A) / / /			
额定脉冲电压(KV)/Rate Impulse Voltage(KV) / / /			
线径范围(硬线和软线)/Wire Range(rigid and flexible)(mm²/AWG) 0.2~1.5/28~16			
间距/Pitch(mm)/线数范围/Poles 3.81/N=02~24P			
剥线长度/Stripping length(mm) 9			
使用温度范围/Operating Temperature(°C) -40~+105			
符合RoHS环保要求/Conform to RoHS Yes			

MATERIAL: SURFACE: 宁波高松电子有限公司 NINGBO DEGSON ELECTRICAL CO., LTD

MAT NO.: / STATUS: / APPD: LiGL 2020.06.17 NAME: 15EDGKD-3.81-XXP-1Y-00A(H)

CHKD: MaEK 2020.06.17 DRFT: ZhuWM 2007.05.31 DRAWING NO.: 15EDGKD-3.81-E01

TYPE: CUSTOMER DRAWING SCALE: 2.5:1 SHEET 1/1

REV	EON	DESCRIPTION	DRFT	DATE	
1	2	3	4	5	6