

1SS/1IS/1LS

Small round caps •
variable heights • illumination option



DISTINCTIVE FEATURES

- Round caps Ø6.5 mm
- 9 different total height options : 8.0 - 22.5 mm
- Full or lens illumination option
- 7 solid, 2 transparent and 5 lens standard colors



SWITCH SPECIFICATIONS : see Multimec™ 5 series.

5E+1SS - SMD

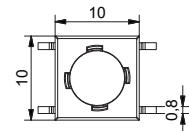
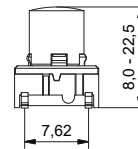
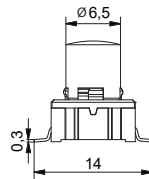

5G+1IS - SMD - W/LED

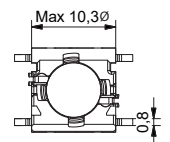
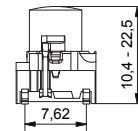
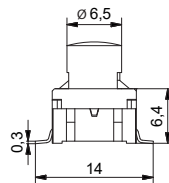

5G+1LS - TH - W/LED

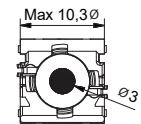
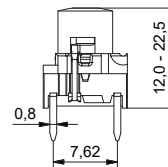
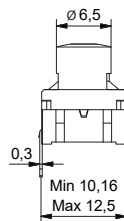

1SS/1IS/1LS

Small round caps •
variable heights • illumination option

BUILD YOUR PART NUMBER

ILLUMINATED

5G

SERIES

ACTUATION FORCE

| | |
|----|------|
| 20 | 2.0N |
| 35 | 3.5N |
| 65 | 6.5N |

CAP

| |
|-----|
| 1LS |
| 1IS |

COLOR

| | |
|-----|---------------|
| 1LS | |
| 09 | black |
| 1IS | |
| 11 | transparent |
| 16 | frosted white |

LENS 1LS

| | |
|---|---------------|
| 1 | transparent |
| 2 | green |
| 4 | yellow |
| 6 | frosted white |
| 8 | red |

HEIGHT

| | |
|------|------|
| 10.4 | 10.4 |
| 11.0 | 11.0 |
| 12.0 | 12.0 |
| 15.0 | 15.0 |
| 16.0 | 16.0 |
| 19.0 | 19.0 |
| 22.5 | 22.5 |

MOUNTING

| | |
|-----|---------------|
| TH9 | through-hole |
| SH9 | surface mount |

LED

| | | | |
|----|----------------------------|------|------------------|
| 02 | blue | 82 | red |
| 22 | green | 2242 | green/ yellow |
| 29 | high intensity green | 8222 | red/green |
| 42 | yellow | 8242 | red/ yellow |
| 61 | white | | |

NON-ILLUMINATED

5E

SERIES

ACTUATION FORCE

| | |
|----|------|
| 20 | 2.0N |
| 35 | 3.5N |
| 65 | 6.5N |

CAP

1SS

COLOR

| | | | |
|----|--------|----|-------|
| 00 | blue | 06 | white |
| 02 | green | 08 | red |
| 03 | grey | 09 | black |
| 04 | yellow | | |

HEIGHT

| | | | |
|------|------|------|------|
| 08.0 | 08.0 | 15.0 | 15.0 |
| 09.5 | 09.5 | 16.0 | 16.0 |
| 10.4 | 10.4 | 19.0 | 19.0 |
| 11.0 | 11.0 | 22.5 | 22.5 |
| 12.0 | 12.0 | | |

MOUNTING

| | |
|-----|---------------|
| TH9 | through-hole |
| SH9 | surface mount |

NOTICE : Please note that not all combinations of above numbers are available. Contact APEM for further information.
Other versions : Please refer to www.apem.com for information on the 3F & 4F series version - 1S



MOUNTING

- Panel cut-out : min. Ø7.0 mm
- Switch spacing AxB : min. 12.7 x 12.7 mm



MATERIALS

- Cap :
 - solid color 1SS: polyamide UL94V2
 - solid color 1LS: ABS UL94HB
 - illuminated : polycarbonate UL94HB
- Lens : polycarbonate UL94HB

Legends

Available for Multimec caps



STANDARD LEGENDS

| STANDARD LEGENDS | | | | | | | | | | |
|------------------|--------|----------|-----------------------|-------|-------------|------|------|------|-----------------|-------------------------|
| LEGEND | 1DS09_ | 1FS096R_ | 1ZB09D_ 1ZB16DLMH_ | 1ZCS_ | 1Z_ 1ZW_ | 10A_ | 10C_ | 10D_ | 10Q_ 10QM16_ | 10R_ & 10RF_ 10RM16_ |
| 0 | 000 | 000 | | | | | | | | |
| 1 | 001 | 001 | | | | | | | | |
| 2 | 002 | 002 | | | | | | | | |
| 3 | 003 | 003 | | | | | | | | |
| 4 | 004 | 004 | | | | | | | | |
| 5 | 005 | 005 | | | | | | | | |
| 6 | 006 | 006 | | | | | | | | |
| 7 | 007 | 007 | | | | | | | | |
| 8 | 008 | 008 | | | | | | | | |
| 9 | 009 | 009 | | | | | | | | |
| # | 107 | 107 | | | | | | | | |
| * | 019 | 019 | | | | | | | | |
| ← | 033 | | | | | | | | | |
| → | 133 | | | | | | | | | |
| ↑ | 034 | | | | | | | | | |
| ↓ | 134 | | | | | | | | | |
| ↙ | 135 | 135 | | | | | | | | |
| + | | | | | | 054 | | | 054 | 054 |
| - | | | | | | 059 | | | 059 | 059 |
| ▲ | | | 136 | | 136 | 136 | | | | |
| ⏻ | 123 | 123 | | 123* | 123 | | 123 | 123 | 123 | 123 |
| ON/OFF | | | | | | | | | 017 | 017 |
| STOP | | | | | | | | | 018 | 018 |
| START | | | | | | | | | 031 | 031 |
| RESET | | | | 038 | | | | | 038 | 038 |
| CANCEL | | | | | | | | | 048 | 048 |
| ENTER | | | | | | | | | 105 | 105 |
| ESC | | | | 051 | | | | | | |
| ON | | | | | | 116 | | | | |
| OFF | | | | | | 117 | | | | |
| OK | | | | 118* | 118 | | 118 | 118 | 118 | 118 |
| SET | | | | 119 | | | | | | |
| MENU | | | | 120 | | | | | | |
| FUNC | | | | 121 | | | | | | |
| HOME | | | | 122 | | | | | | |

STANDARD OPTIONS

- 1DS: pad printed
- 1FS: reverse printed
- 1ZB: pad printed / laser marked
- 1ZCS: pad printed / *reverse printed / *laser marked
- 1Z & 1ZW: pad printed / laser marked
- 10A: pad printed / laser marked
- 10C: pad printed / laser marked
- 10D: UV printed / laser marked
- 10R(F) & 10Q: pad printed / reverse printed
- 10RM & 10QM: metal symbol



HOW TO ORDER

POSITIONING OF LEGENDS ON ROCKER-ACTION CAPS

When ordering legends for caps with hinge-type cap retention system, it is important to note the position of the cap. An extra letter (U, D, R or L) needs to be added to the part number to refer to the position of the hinges in relation to the legend. See samples:

Rocker-action caps without a lens: 1A, 1B, 1M, 1ZA and 1ZB

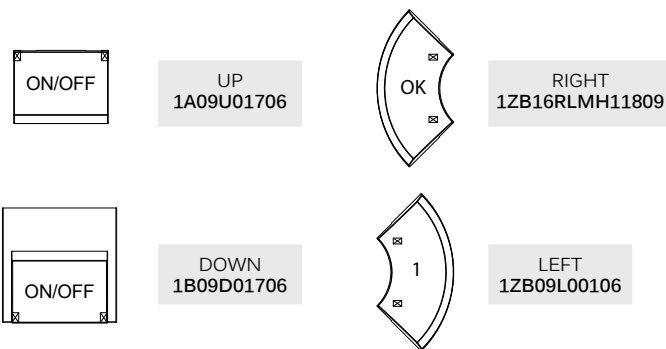

LEGEND ILLUMINATION

- **Option 1 - laser marked:** In case of laser marked legends an "LM" is added after the cap colour, before the legend code. We recommend using hard paint (additional "H") for increased lifetime of the paint. E.g. 1ZB16DLMH13609
- **Option 2 - reverse printed:** In case of reverse printed caps an "R" is added after the cap colour, before the legend code. Especially relevant when standard legends have both negative and positive print options. E.g. 1FS096R00009
- **Option 3 - metal symbol:** Only available for 10RM and 10QM (therefore the "M"). E.g. 10RM16059

ORIENTATION OF THE SWITCH

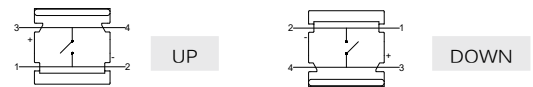

STANDARD AND CUSTOM LEGENDS

- Standard are only certain legends on certain caps. See the table on the previous page.
- All standard pad-printed legends are white on black caps.
- All standard reverse-printed and laser marked legends are black on frosted white cap.

STANDARD LEGENDS

| CAP | CAP COLOR | DIRECTION* | TYPE* | LEGEND | LEGEND COLOR* | |
|-----|------------------|---------------------------|--------------------------------|---------|--|--|
| 1DS | 00 Blue | D Down | UV UV printed | 001 1 | 00 Blue | |
| 1FS | 02 Green | U Up | LM Laser marked on soft paint | 002 2 | 02 Green | |
| ... | 03 Grey | R Right | LMH Laser marked on hard paint | 003 3 | 03 Grey | |
| | 04 Yellow | L Left | R Reverse printed | ... etc | 04 Yellow | |
| | 06 White | *Only for hinge-type caps | | | 06 White | |
| | 08 Red | | *In case of illumination | | 08 Red | |
| | 09 Black | | | | 09 Black | |
| | 16 Frosted white | | | | ... Etc | |
| | ... Etc | | | | *In case of reverse printed and laser marked legends the colour of the paint | |













































Notice: The size of the legends listed may not correspond to the actual size.

If you decide to use one of the standard legends without any adjustments (without a new cliché or programming) on another cap than designated in the table, then there is no cliché or programming cost, for this to apply the cap has to be black and the print white.

For further information on legends please contact your local distributor or MEC.

Solid colors

Available for Multimec™ caps

| | | Colour / RAL Code | | | | | | | | | | | | | | | | | | | |
|----------------|---|---|---|---|---|---|---|---|---|---|---|---|---|--|---|---|---|---|---|---|---|
| | | Blue / 5012 | green / 6018 | Grey / 7004 | Yellow / 1023 | White / 9010 | Red / 3000 | Black / 9004 | Ultra blue / 5002 | Mint green / 6029 | Tele grey / 7046 | Melon / 1028 | Signal white / 9003 | Noble red / 3002 | Dusty blue / 5014 | Aqua blue / 5021 | Metal dark blue / No ral code | Metal light grey / No ral code | Metal dark grey / No ral code | Metal bordeaux / No ral code | |
| CAP | CODE |  |  |  |  |  |  |  |  |  |  |  |  |  |  |  |  |  |  |  | |
| 1A |  | • | • | • | • | • | • | • | | | | | | | | | | | | | |
| 1B |  | • | • | • | • | • | • | • | | | | | | | | | | | | | |
| 1DS |  | • | • | • | • | • | • | • | • | • | • | • | | • | • | • | • | • | • | • | • |
| 1ES/1FS |  | | | • | | | • | • | | | | | | | | | | | | | |
| 1GAS/1GCS |  | • | • | • | • | • | • | • | | | | | | | | | | | | | |
| 1H |  | | | • | | | | • | | | | | | | | | | | | | |
| 1JS |  | • | • | • | • | • | • | • | | | | | | | | | | | | | |
| 1KS |  | • | • | • | • | • | • | • | | | | | | | | | | | | | |
| 1LS |  | | | | | | | • | | | | | | | | | | | | | |
| 1M |  | | • | • | | | • | • | | | | | | | | | | | | | |
| 1NS |  | | | • | | | | • | | | | | | | | | | | | | |
| 1PS |  | • | • | • | • | • | • | • | | | | | | | | | | | | | |
| 1QS |  | • | | • | | | | • | | | | | | | | | | | | | |
| 1RS |  | | | • | | | | | | | | | | | | | | | | | |
| 1SS |  | • | • | • | • | • | • | • | | | | | | | | | | | | | |
| 1TS/1US/1VS |  | • | | • | | | • | • | | | | | | | | | | | | | |
| 1WAS/1WDS/1WPS |  | | | • | | | | • | | | | | | | | | | | | | |
| 1XS |  | | | • | | • | | • | | | | | | | | | | | | | |
| 1ZA |  | | | • | | • | | • | • | | | | | | • | • | • | • | • | • | • |
| 1ZB |  | | | • | | • | | • | • | | | | | | • | • | • | • | • | • | • |
| 1ZCS |  | | | • | | • | • | • | • | | | | | | • | • | • | • | • | • | • |
| 1Z/1ZW |  | | | • | | • | | • | | | | | | | | | | | | | |
| 10A |  | | | • | | | • | • | | | | | | | | | | | | | |
| 10C |  | • | | • | | | • | • | | | | | • | | | | | | | | |
| 10D |  | | | • | | • | | • | | | | | | | | | | | | | |
| 10R/10RF + 10Q | | • | • | • | • | • | • | • | | | | | | | | | | | | | |

The RAL Codes mentioned are the codes nearest to the solid colors in the multimec™ range.

Cap & Bezel Specifications

Multimec™ caps

ACCESSORY SPECIFICATIONS

| MATERIAL | PARTS | TEMP. LIMIT | UL RATING |
|------------------|---|--------------------------|-----------|
| ABS | Solid color 1A, 1B, 1DS, 1ES, 1FS, 1H, 1JS, 1KS, 1LS, 1M, 1NS, 1PS, 1QS, 1RS, 1TS, 1US, 1VS, 1WAS, 1WDS, 1WPS, 1XS, 1Z, 1ZA, 1ZB, 1ZCS, 1ZW, 10A, 10C, 10Q, 10R, 10RF and AQCS Bezels 2C, 2D and 2K, reflectors for 1KBS, 1KCS, 1YS and 1YAS | Max 65 °C Max 149 °F | UL94HB |
| Polycarbonate | All lenses and transparent colour caps, lids for 1KBS & 1KCS | Max 85 °C Max 185 °F | UL94HB |
| Polyamide | 1GAS, 1GCS, 1SS and 2SS | Max 160 °C Max 320 °F | UL94V2 |
| Legends adhesion | DS/EN ISO 2409 Class 1 & ASTM D3359 Class 4B | | |

EXTENDERS



5 mm, 6 mm,
7 mm, 8 mm,
9 mm, 10 mm

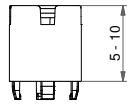

2SS

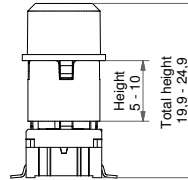

SMD + 2SS+1DS

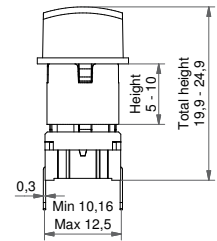

TH+2SS+1TS

HOW TO USE 1GAS/1GCS + 2SS UNDER FOIL

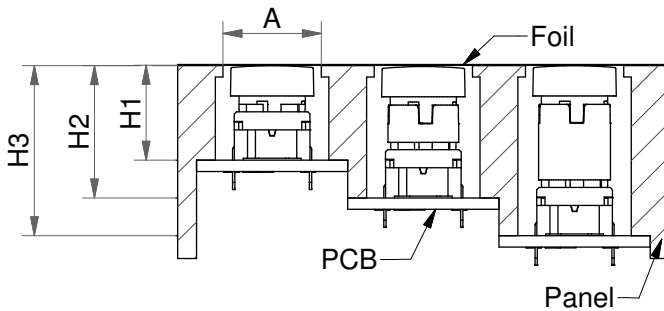

- A=We recommend space for travel of the foil and leave the area free from adhesive.
- H=We recommend you to calculate this dimension from the top of the PCB to the inner top of the panel.

2SS CAN BE USED WITH ALL 5G-TYPE SNAP-ON CAPS

All 2SS extenders are stackable giving the possibility to match most overall heights.

| CAP SERIES | ORIGINAL HEIGHT (H1) | HEIGHT WITH A SINGLE EXTENDER (H2,H3) |
|----------------|----------------------|---------------------------------------|
| 1DS/1ES/1FS | 14.9 | 19.9-24.9 |
| 1GAS/1GCS | 12.5 | 17.5-22.5 |
| 1KS/1KBS/1KCS | 19.1 ; 20.2 ; 20.1 | 24.1; 25.2; 25.1-29.1; 30.2; 30.1 |
| 1NS | 14.9 | 19.9-24.9 |
| 1TS/1US/1VS | 14.9 | 19.9-24.9 |
| 1WAS/1WDS/1WPS | 15.7 | 20.7-25.7 |
| 1XS | 18.5 | 23.5-28.5 |
| 1ZCS | 11.7 | 16.7-21.7 |
| 10C | 13.7 | 18.7-23.7 |
| 10D | 12.0 | 17.0-22.0 |

Cap & Bezel Specifications

Multimec™ caps



HOW TO ORDER

EXTENDERS

| SWITCH | MOUNTING | ACTUATION FORCE | LED (OPTIONAL) | CAP | EXTENDER 2SS HEIGHT |
|--------|---------------------------------------|-----------------|--|------------------------------------|----------------------------------|
| 5G | TH9 Through-hole SH9 Surface mount | 20 35 65 | 02 blue 22 green 42 yellow 61 white 82 red 2242 green/yellow 8222 red/green 8242 red/yellow | See the table on the previous page | 05 06 07 08 09 10 |

Multimec™ 5

High performance tactile switches •
MIL-PRF-28855H • excellent illumination



DISTINCTIVE FEATURES

- Large range of accessories
- Momentary switches with NO or NC/NO function
- Sealed to IP67
- Single or bi-color illumination option
- Illumination with integrated chip-LEDs



ENVIRONMENTAL SPECIFICATIONS

- Sealing : IP67 according to IEC 60529
- Working and storage temperature :
 - non-illuminated : -40 °C/+160 °C (-40 °F to +320 °F)
 - illuminated : -30 °C/+85 °C (-22 °F to +185 °F)
- Soldering :
 - through-hole : IEC 60068-2-20 8
 - surface mount : JEDEC J-STD-020E



ELECTRICAL SPECIFICATIONS

- Recommended load :
 - Gold contacts : 0.5 μ-50 mA 24 VDC
 - Silver contacts : 0.5-50 mA 24 VDC
- Contact resistance : <30 mΩ - typically 10 mΩ
- Insulation resistance : >10 MΩ
- Contact bounce : <2 mS - typically 0.5 mS



MECHANICAL SPECIFICATIONS

- Standard actuation force :
 - momentary NO : 2.0 N, 3.5 N, 6.5 N
 - quiet version : 2.0 N
 - NC/NO function : 3.5 N
- Max. actuation force :
 - momentary : 115 N for 60 sec (according to MIL-PRF-22885H)
 - NC/NO : 100 N for 10 sec
- Travel : 1 mm
- Lifetime : >10,000,000 cycles

The company reserves the right to change specifications without notice.



MATERIALS

- Housing : PPS UL94V0
- Actuator : PPS UL94V0
- Sealing : Silicone rubber
- Contacts spring : Stainless steel
 - Silver : +3 μAg
 - Gold : +1 μAu
- Fixed contacts :
 - Silver : SnCu + 2μNI + 3μAg
 - Gold : SnCu + 2μNI + 1μAu
- Terminals : SnCu + 2μNI + 3μSn100

Multimec™ 5

High performance tactile switches • MIL-PRF-28855H • excellent illumination

5G NON-ILLUMINATED

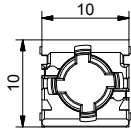

- SMD, TH or right angle TH
- NO or NC/NO

5G ILLUMINATED

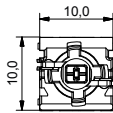

- SMD or TH
- NO
- single or bi-color LEDs

5E NON-ILLUMINATED

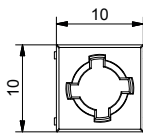

- SMD, TH or right angle TH
- NO or NC/NO

All tolerances unless otherwise noted : ±0.2 mm

PCB LAYOUT & CIRCUIT DIAGRAM

Non-illuminated

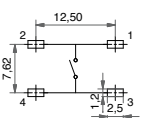
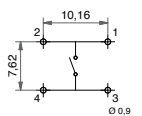

Single LED

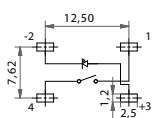
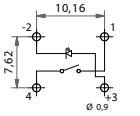

Bicolor - 2 LEDs

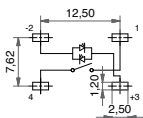
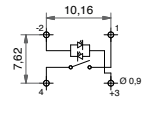

RAS

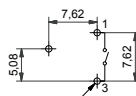

NC/NO function

*not for sale in Japan

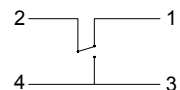

SMD

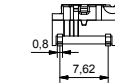
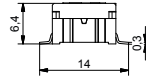

TH

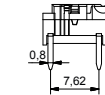
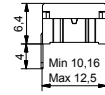

RAS

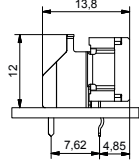
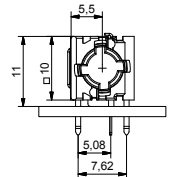

SMD

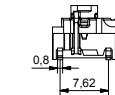
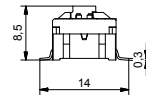

TH

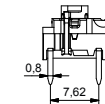
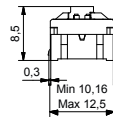

SMD

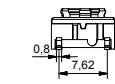
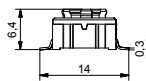

TH

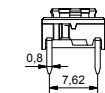
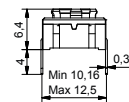

RAS

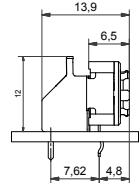
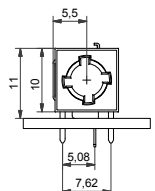

High performance tactile switches • MIL-PRF-28855H • excellent illumination



BUILD YOUR PART NUMBER

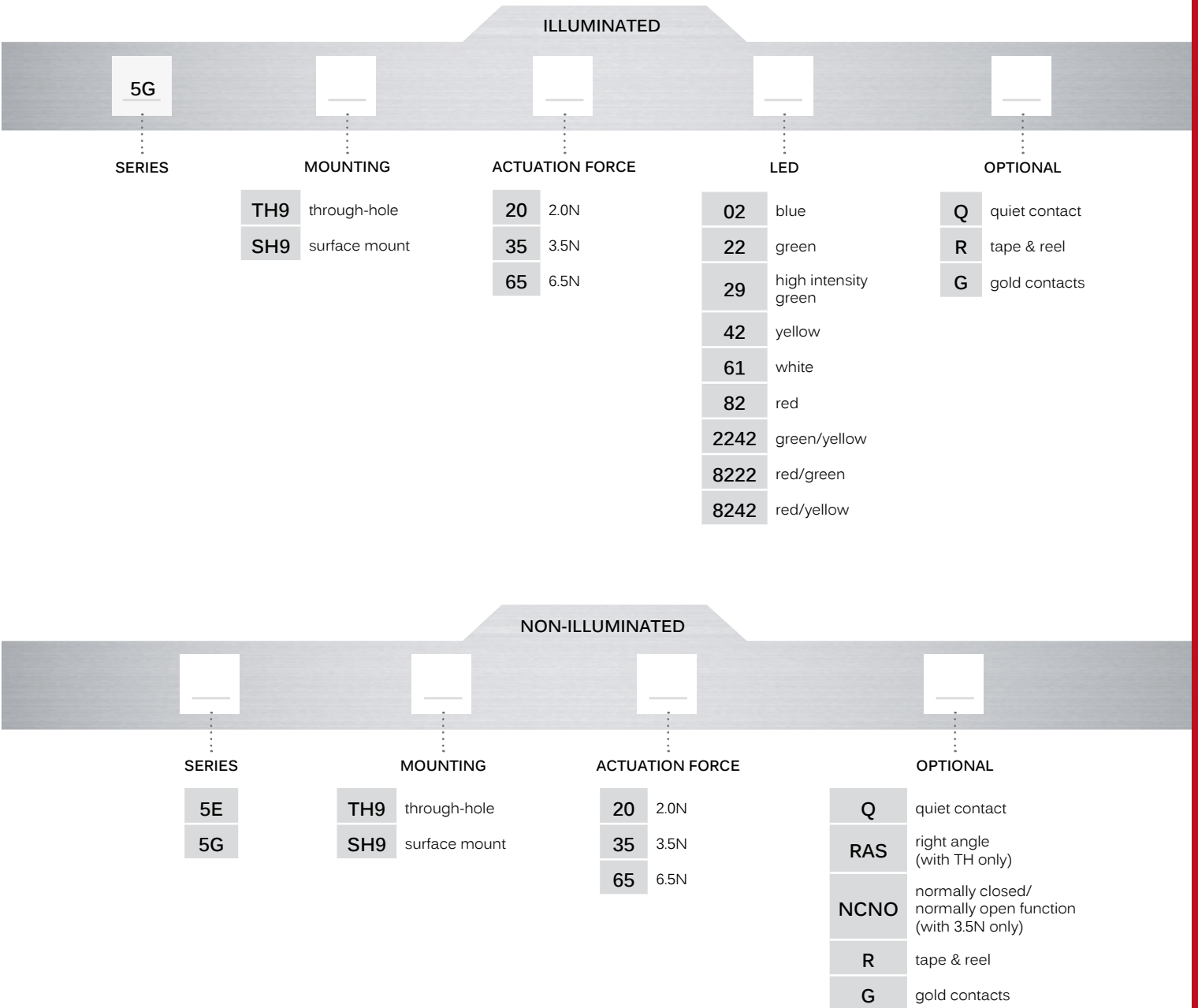

ABOUT THIS SERIES



Notice : please note that not all combinations of above numbers are available. Refer to www.apem.com for further information.

Multimec[®] 5

High performance tactile switches •
MIL-PRF-28855H • excellent illumination



TAPE & REEL

Tape and reel is available for the parts listed and has the following specifications

- Reel diameter: Ø330 mm
- Tape width: 24 mm
- Pitch: see list
- Tape and reel material: antistatic or better
- Quantity per reel: see list

| PART NO. | ORDERING CODE | PITCH | QUANTITY PER REEL |
|-------------------|--------------------|-------|-------------------|
| 5XSH9XX | 5XSH9XXR | 16 | 500 |
| 5XSH9XX1SSXX-08.0 | 5XSH9XXR1SSXX-08.0 | 20 | 250 |
| 5XSH9XX1SSXX-09.5 | 5XSH9XXR1SSXX-09.5 | 20 | 250 |
| 5XSH9XX1SSXX-10.4 | 5XSH9XXR1SSXX-10.4 | 20 | 250 |
| 5XSH9XX1SSXX-11.0 | 5XSH9XXR1SSXX-11.0 | 20 | 250 |
| 5XSH9XX1SSXX-12.0 | 5XSH9XXR1SSXX-12.0 | 20 | 250 |
| 5GSH9XX02 | 5GSH9XX02R | 20 | 250 |
| 5GSH9XX22 | 5GSH9XX22R | 20 | 250 |
| 5GSH9XX42 | 5GSH9XX42R | 20 | 250 |
| 5GSH9XX61 | 5GSH9XX61R | 20 | 250 |
| 5GSH9XX82 | 5GSH9XX82R | 20 | 250 |
| 5GSH9XX2242 | 5GSH9XX2242R | 20 | 250 |
| 5GSH9XX8222 | 5GSH9XX8222R | 20 | 250 |
| 5GSH9XX8242 | 5GSH9XX8242R | 20 | 250 |



OPERATING FORCE

2.0 N

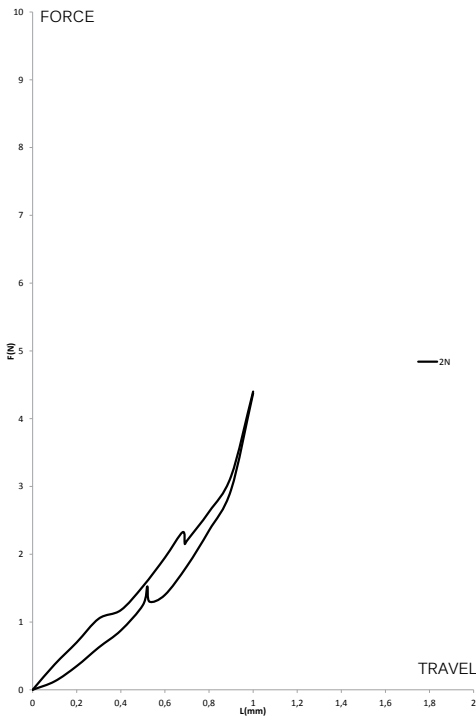

3.5 N

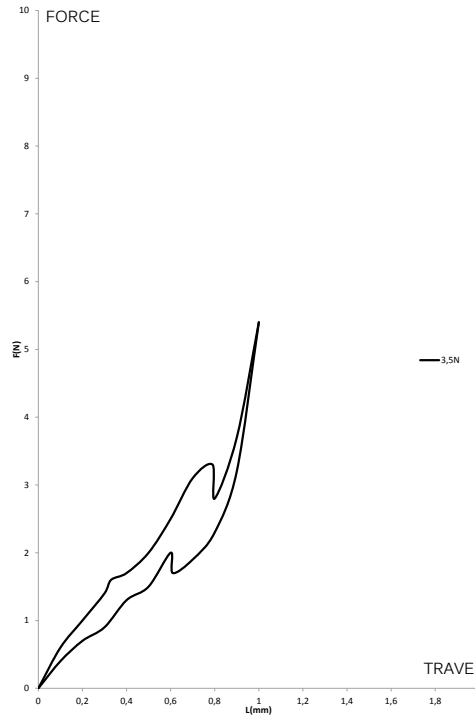

6.5 N

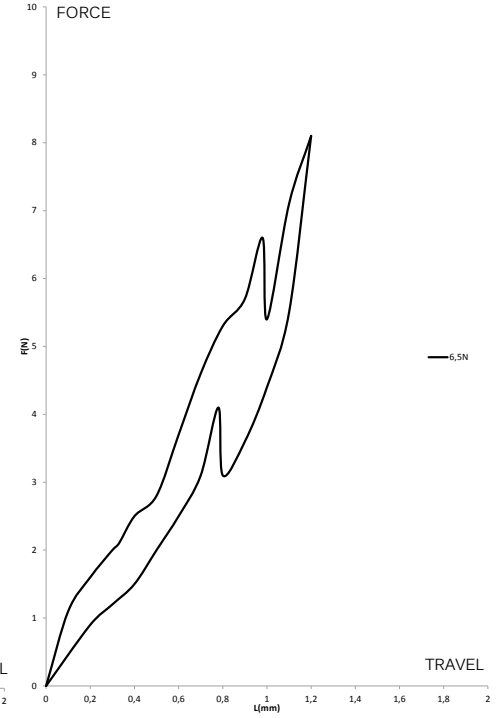

Multimec® 5

High performance tactile switches • MIL-PRF-28855H • excellent illumination



RECOMMENDED OPERATING CONDITIONS

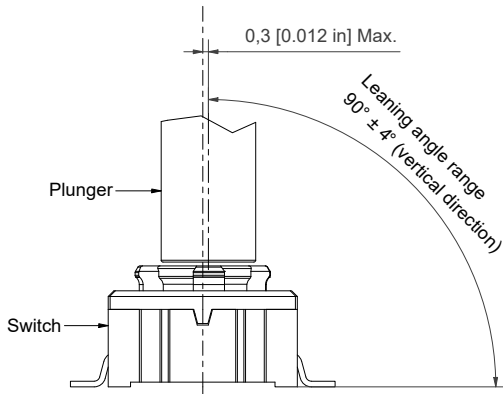

For the optimal performance of the switch use the recommended operating conditions.



MOUNTING

MOUNTING TOOLS FOR MULTIMEC® THROUGH-HOLE SWITCHES

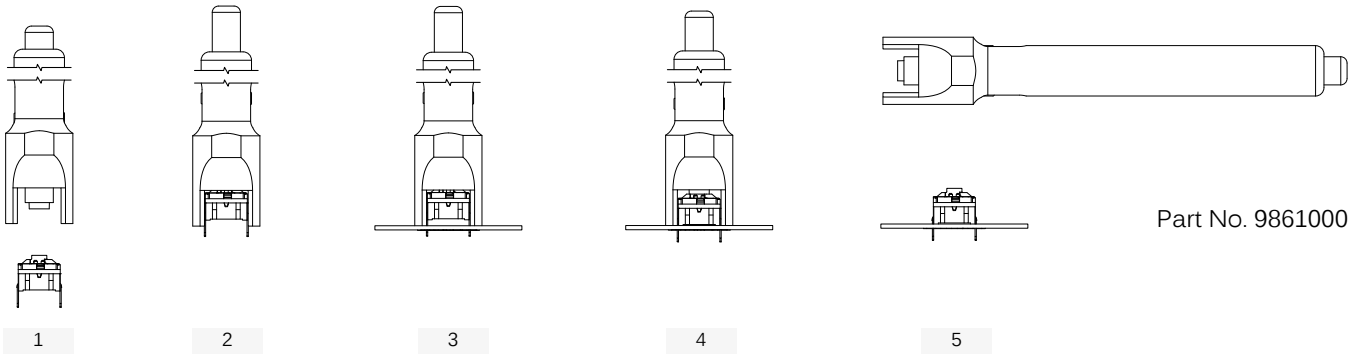

MULTIMEC® SPACING EXAMPLES

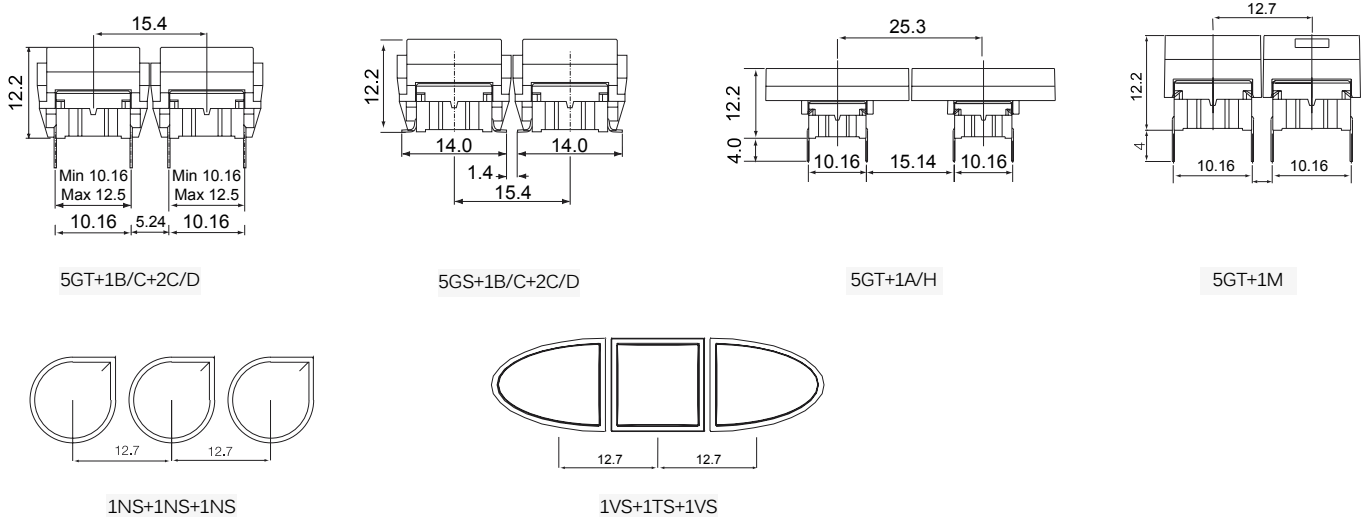

Multimec[®] 5

High performance tactile switches •
MIL-PRF-28855H • excellent illumination



MOUNTING (CONTINUED)

SPACE REQUIREMENT - MATRIX MOUNTING

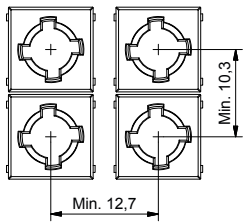

Through-hole (TH)

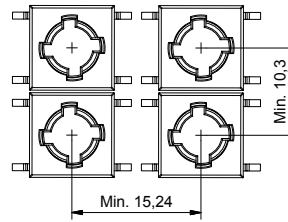

Surface mount (SMD)

SPACE REQUIREMENT - SWITCH/CAP

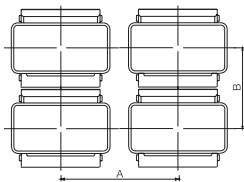

Switch spacing

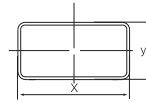

Cap dimensions

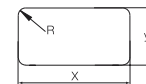

Panel cut-out

| CAP SERIES | RECOMMENDED MIN. SWITCH SPACING AxB | NOMINAL CAP DIMENSION WxH | RECOMMENDED MIN. PANEL CUT-CUT |
|---------------|-------------------------------------|---------------------------|--------------------------------|
| 1A/1H | 12.7x10.16 | 12.6x10.1 | 13.0x10.5 |
| 1B+2C/2D | 15.24x15.24 | 15.1x15.1 | 15.5x15.5 |
| 1DS/1ES/1FS | 12.7x12.7 | Ø9.6 | Ø10 |
| 1GAS | 12.7x11.14 | Ø11 | Ø11.4 |
| 1GCS | 15.14x15.14 | Ø15 | Ø15.4 |
| 1JS | 12.7x12.7 | Ø9.6 | Ø10.4 |
| 1KS/1KBS/1KCS | 15.24x15.24 | 14.3x14.3 | 14.7x14.7 |
| 1M | 25.4x10.16 | 25x10 | 27.7x10.5 |
| 1NS | 12.7x12.7 | Ø9.8/ □4.9 | Ø10.2/□5.1 |
| 1PS/ 1QS/1RS | 15.24x10.16 | 6.5x12.5 | 7x13, R max. 1 |
| 1SS/1IS/1LS | 12.7x12.7 | Ø6.5 | Ø7 |
| 1TS | 12.7x12.7 | 10.6x10.6 | 11x11 |
| 1US | 12.7x12.7 | Ø10.6 | Ø11 |
| 1VS | 12.7x12.7 | 10.6x13.25 | 11.0x13.65 |
| 1WAS/1WPS | 12.7x10.3 | 12.5x6.5 | 12.9x6.9 |
| 1WDS | 15.34x10.3 | 15.2x8 | 15.6x8.4 |
| 1XS | 12.7x12.7 | 9.4x7.4 | 9.8x7.9 |
| 1YS/1YAS | 18.84x10.3 | 18.7x10.1 | 19.4x10.5 |
| 1ZA | 17x17 | 15x15 | 16x16 |
| 1ZB | 24.34x12.1 | R1=7.4; R2=17.5 90° | R1=7.1; R2=17.5-17.75 90° |
| 1ZCS | 14.44x14.44 | Ø14.3 | Ø14.7 |
| 1Z/1ZW | 35.5x35.5; 41.6x41.6 | Ø29.5 | Ø30.3 |
| 10A | 17x35 | R=5.3; 10.6x28 | R=5.5; 11x28.4 |
| 10C | non-ill: 24 x 24; ill.: 30.2x30.2 | Ø19.2 | Ø19.8 |
| 10D (+10DWY) | 19x19 (27x27) | Ø16 | Ø16.4 |
| 10R/10RF/10RM | 40.5x40.5 | Ø30 | Ø30.6 |
| 10Q/10QM | 32.5x32.5 | 22x22 | 22.5x22.5 |



LED COMPONENT SPECIFICATIONS

| LED COMPONENT SPECIFICATIONS | | | | | | | |
|---|----------|--------------------|---------|---------|---------|---------|----------------------|
| Color | | Blue | Green | Yellow | White | Red | High Intensity Green |
| Color Codes | | 02 | 22 | 42 | 61 | 82 | 29 |
| ABSOLUTE MAXIMUM RATINGS (Ta= 25°C) | | | | | | | |
| Power | mW | 110 | 75 | 60 | 48 | 65 | 102.5 |
| Current forward | mA | 25 | 30 | 25 | 15 | 25 | 25 |
| Forward peak current | mA | 100 | 80 | 60 | 100 | 100 | 150 |
| Voltage reverse | V | 5 | 5 | 5 | NA | 12 | 5 |
| Operating temperature | °C | -40/+85 | -55/+85 | -40/+85 | -40/+85 | -30/+85 | -40/+85 |
| Storage temperature | °C | -40/+90 | -55/+85 | -40/+90 | -40/+85 | -40/+85 | -40/+85 |
| Soldering temperature | °C | 245 for max 10 sec | | | | | |
| ELECTRICAL-OPTICAL CHARACTERISTICS (Ta=25 °C) | | | | | | | |
| Voltage forward | Typ. V | 3.3 | 2 | 1.75** | 2.85 | 2 | 3.3 |
| | Max. V | 3.7 | 2.4 | 2.35 | 3.1 | 2.5 | 4.1 |
| Current reverse (VR=5V) | Max. µA | 50 | 100 | 10 | NA | 100 | 50 |
| Wave length | nm | 470 | 571 | 591 | NA | 633 | 525 |
| Spread | Δnm | 25 | NA | 15 | NA | 16 | 30 |
| Spread angle | degree | 120 | 130 | 120 | 150 | 160 | 60 |
| Luminous Intensity | Min. mcd | 45 | 18 | 28.5 | 71 | 28 | 500 |
| | Typ. mcd | 122* | 35 | 72* | 224* | 180* | 1000 |
| Optical intensity | Lm/w | NA | NA | NA | 36 | 7 | NA |

*F=20 mA, **Pulse width 1ms Duty cycle 1:5, ***F=50 mA, ****Luminous Flux mlm

Multimec® 5

High performance tactile switches • MIL-PRF-28855H • excellent illumination



USAGE GUIDELINES

HOW TO GET THE BEST RESULTS WITH MEC SWITCHES ?

These guidelines are offered to users of MEC Switches as an aid to ensure successful and reliable switch operation. Please see the technical specifications for details on operating and storage temperatures and soldering guidelines to make sure you select the best switch for your application. When wave soldering is taking place, MEC strongly recommend that the temperature profile is analyzed and compared with the temperature rating of the switch. It is also important to monitor the accumulated heat buildup from both the pre-heat zones and the solder zone.

Most standard accessories for multimec® 5 series switches are made from ABS plastic with a maximum operating temperature of 65 °C. It is strongly recommended that accessories are mounted after soldering of the switch. If this is not possible care must be taken not to overheat the accessories during the soldering process. The 1SS and 1GAS/1GCS caps are, however, made of high temperature materials and will meet the same temperature specifications as the switches. For accessories made from other plastic materials please see multimec® 5 series technical specifications.

LEDs have their own temperature specifications. When fitted in a switch the LED will determine the max. operating temperature, i.e. 5GTH93522 has an upper temperature limit of 85 °C!

MOUNTING AND DISMOUNTING

If switches are to be mounted in rows it is essential that the recommendations regarding spacing are followed. PC board thickness should be 1.4 ±0.2 mm and terminal hole diameter should be 0.9 mm.

All multimec® 5 series caps and bezels are easily snapped onto the switch modules and can be changed at a later time.

A mounting tool is available for through hole multimec® 5 series switches.

SOLDERING AND CLEANING MULTIMEC® SERIES

Multimec® 5 series switches are fully sealed to IP67 specifications to minimize solder flux and aqueous based cleaning solutions from entering the switch and contaminating the contacts. The switches can be placed on the PC board with other components and wave soldered. Multimec® 5 series offers a high level of sealing, however, with aqueous solvent solutions care must be taken to avoid the worst

case situation with water jets, complete immersion into a liquid with a temperature below the board or surface tension reducing additives.

Recommended cleaning methods are demineralized water. Any surface tension reducing agents, such as soap, must not be used as they risk causing a potential leakage of the switch.

SOLDERING - THROUGH HOLE VERSIONS

Hand soldering: max. 350 °C for max. 3 sec

Wave soldering: heat built up in the switch during pre-heating and soldering must not exceed the maximum operating temperature of the switch. Peak temperature must not exceed 260 °C, and soldering time is max 10 sec. (IEC 60068-2-20 8)

SOLDERING - SURFACE MOUNT VERSIONS

For all methods - infrared, convection and vapor phase. The upper limit 240 °C/40 sec must be observed. The soldering temperature profile must have moderate temperature gradients. (JEDEC J-STD-020E)

ROHS COMPLIANCE

As of 1 July 2006 MEC has completed the conversion to RoHS compliance. For more info please see our homepage www.apem.com

TEMPERATURE LIMITS:

| | |
|-------------|--------------|
| Switch | 160 °C |
| LEDs | 85/90 °C |
| Accessories | 65/85/160 °C |

PACKAGING

Multimec® 5 series switches are packed in rigid tubes of 50 pieces each.

A box contains 1.000 pcs.

The surface mount versions of multimec® 5 series switches with a height up to 12.5 mm can also be delivered on tape/reel.

Each reel contains 250/500 pcs.