

Click to
ORDER
samples

AM10GH-NZ



Aimtec adds the AM10GH-NZ 10W series to its SIP8 DC/DC converters family. This new series now increases the power density of our SIP8 line from 9W to 10W.

The AM10GH-NZ series provide a 4:1 ultrawide input voltage range and comes standard with single regulated output voltages of 3.3, 5, 9, 12, 15 and 24VDC with an I/O isolation of 1500VDC. Thanks to its wide -40°C to +85°C operating temperature range, the AM10GH-NZ is suitable for applications that include industrial control, grid power, instrumentation and telecommunication. In addition to meeting EN62368 certification, protections for input under-voltage, output short circuit, over-current are also included, increasing the overall safety of your new system design.

Features

- Ultra-wide input voltage range: 9-36VDC
- Operating temperature range: -40°C to +85°C
- Efficiency high up to 86%
- Input under-voltage protection, output short circuit, over-current protection
- High power density, SIP8 package
- International standard pin-out

Summary

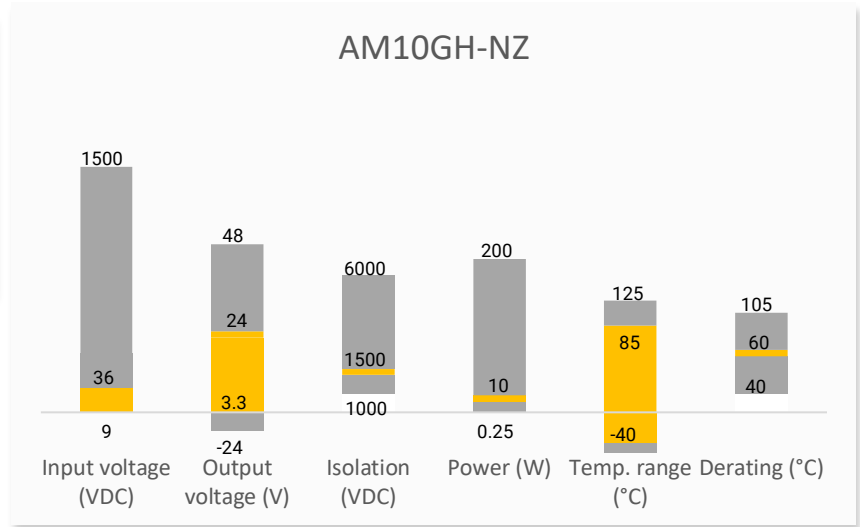

Training

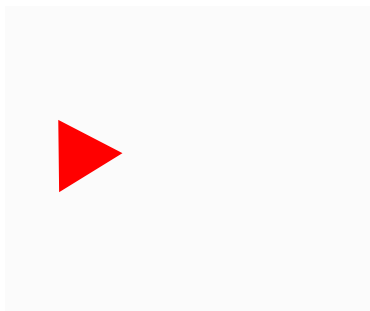

Product Training Video
(click to open)

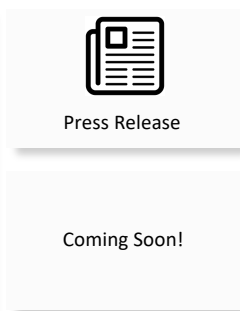

Application Notes

Applications



Power Grid



Industrial



Telecom



Instrumentation

Models & Specifications

Single Output

Model	Input Voltage (VDC)	Output Voltage (VDC)	Input Current max (mA)	Output Current max (A)	Isolation (VDC)	Maximum capacitive Load (μ F)	Efficiency Full Load (Min.) (%)
AM10GH-2403NZ	24 (9 - 36)	3.3	398	2.40	1500	2200	82
AM10GH-2405NZ	24 (9 - 36)	5	485	2.00	1500	2200	85
AM10GH-2409NZ	24 (9 - 36)	9	485	1.11	1500	680	86
AM10GH-2412NZ	24 (9 - 36)	12	485	0.83	1500	470	86
AM10GH-2415NZ	24 (9 - 36)	15	485	0.67	1500	330	86
AM10GH-2424NZ	24 (9 - 36)	24	485	0.42	1500	220	85

Input Specification

Parameters	Conditions	Typical	Maximum	Units
Voltage range	Nominal 24V	9 – 36		VDC
Filter	Capacitance Filter			
Input under-voltage lockout		6.5		VDC
Absolute maximum rating	1 Sec.	≥ -0.7	50	VDC
Input reflected ripple current		50		mA pk-pk
On/Off Control	ON – 3.5 to 12Vdc or open OFF – 0 to 1.2Vdc or connected to “-V Input”, idle current 10mA max.			

Note: The voltage of Ctrl pin is relative to “-V Input” pin .

Isolation Specification

Parameters	Conditions	Typical	Maximum	Units
Tested I/O voltage	60 sec, < 1mA	1500		VDC
Resistance	500Vdc	>1000		MOhm
Capacitance	Input to output , 100KHz/0.1V	1000		pF

Output Specification

Parameters	Conditions	Typical	Maximum	Units
Voltage accuracy	5-100% load	± 1.5	± 2.0	%
Line regulation	Full load, main input range	± 0.25	± 0.5	%
Load regulation	5-100% load	± 0.5	± 1.0	%
Short circuit protection	Continuous, Auto recovery			
Over current protection		160	230	% of Iout
Temperature coefficient	Full load		± 0.03	%/°C
Ripple & Noise*	20MHz bandwidth, 5-100% load	75	150	mV pk-pk
Transient recovery time	25% load step change	300	500	μ S
Transient response deviation	25% load step change, 3.3/5V Output	± 5	± 8	%
	25% load step change, Others	± 3	± 5	%

* Ripple & noise under 0-5% load is 300mV max. Please refer to the ripple & noise reduction circuit for testing method.

General Specifications				
Parameters	Conditions	Typical	Maximum	Units
Switching frequency*	100% load	500		KHz
Operating temperature	See derating graph	-40 to +85		°C
Storage temperature		-55 to +125		°C
Maximum case temperature			95	°C
Lead temperature	1.5mm from case 10 sec.		300	°C
Cooling	Free air convection			
Humidity	Non-condensing		95	% RH
Case material	Heat resistant black Plastic (flammability to UL 94V-0)			
Weight		5.5		g
Dimensions (L x W x H)	0.87 x 0.37 x 0.47 inches, 22.00 x 9.50 x 12.00mm			
MTBF	> 1 000 000 hrs (MIL-HDBK -217F, t=+25°C) / Full Load			

*Switching frequency reduces when load under 50%.
All specifications in this datasheet are measured at an ambient temperature of 25°C, humidity<75%, nominal input voltage and at rated output load unless otherwise specified.

Environmental Specifications	
Parameters	
Vibration	10-150Hz, 5G, 0.75mm, 90minutes, along X, Y and Z

Safety Specifications		
Parameters		
Standards	Information technology Equipment	Design to meet IEC/UL/EN 62368
	EMC - Conducted and radiated emission	EN55032, CLASS B with EMC circuit part A
	Electrostatic Discharge Immunity	IEC 61000-4-2 Contact ±6KV , Criteria B
	RF, Electromagnetic Field Immunity	IEC 61000-4-3 10V/m, Criteria A
	Electrical Fast Transient/Burst Immunity	IEC 61000-4-4 ±2KV, Criteria B with EMC circuit part B
	Surge Immunity	IEC 61000-4-5 L-L ±2KV, Criteria B with EMC circuit part B
	RF, Conducted Disturbance Immunity	IEC 61000-4-6 3Vr.m.s, Criteria A

Ripple & Noise Reduction Circuit

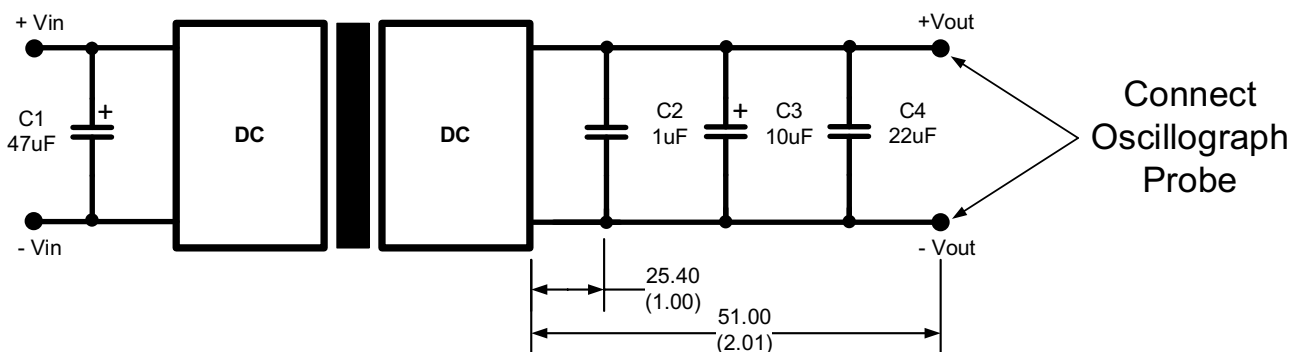

Derating

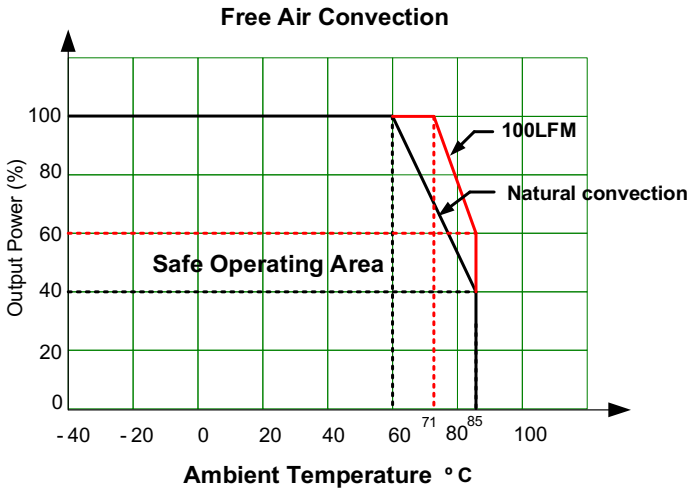

Typical Application Circuit

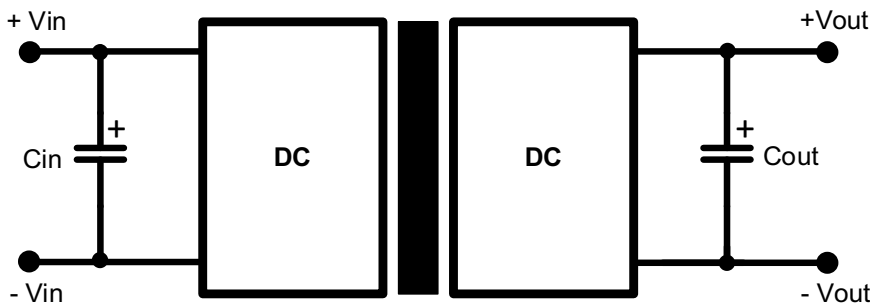

Vout(VDC)	Cin	Cout
3.3, 5, 9	47 μ F/100V	22 μ F/16V
12, 15	47 μ F/100V	22 μ F/25V
24	47 μ F/100V	22 μ F/50V

Recommended EMC Circuit

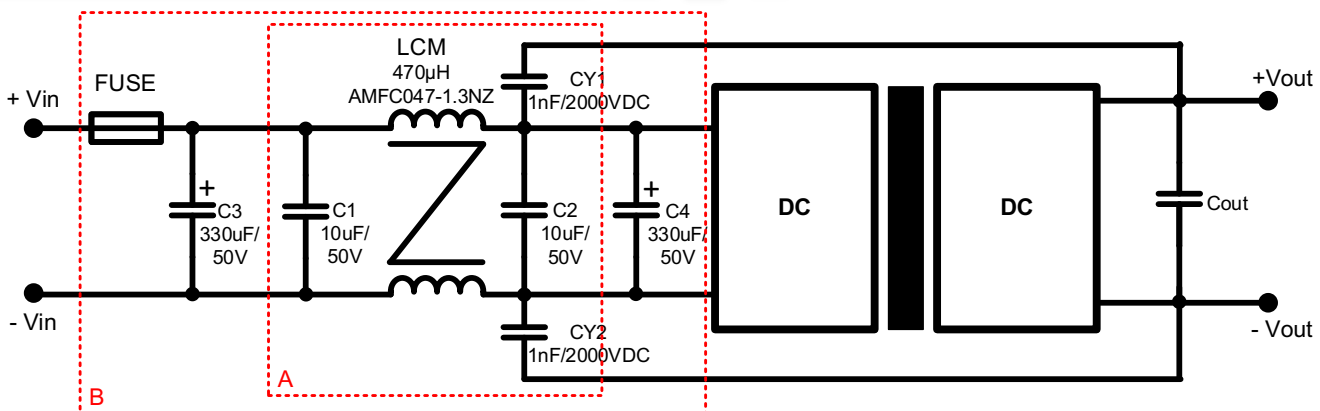

Notes: Part A for EMI filtering and Part B is used for EMS test.

Dimensions

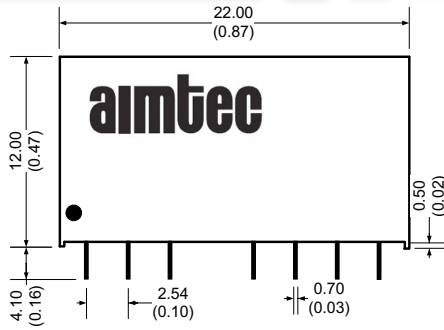

Dimensions mm (inch)
Case Tolerance ± 0.50 (± 0.02)
Pin Diameter ± 0.10 (± 0.004)

Pin	Single
1	-V Input
2	+V Input
3	Ctrl
5	NC
6	+V Output
7	-V Output
8	NC

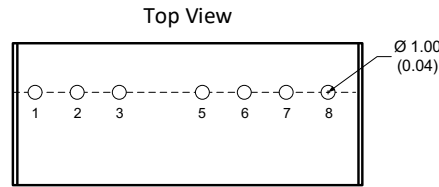
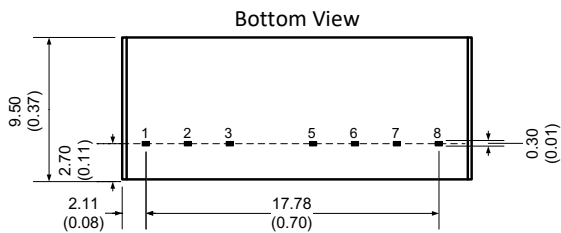

NOTE: **1.** Datasheets are updated as needed and as such, specifications are subject to change without notice. Once printed or downloaded, datasheets are no longer controlled by Aimtec; refer to www.aimtec.com for the most current product specifications. **2.** Product labels shown, including safety agency certifications on labels, may vary based on the date manufactured. **3.** Mechanical drawings and specifications are for reference only. **4.** All specifications are measured at an ambient temperature of 25°C, humidity < 75%, nominal input voltage and at rated output load unless otherwise specified. **5.** Aimtec may not have conducted destructive testing or chemical analysis on all internal components and chemicals at the time of publishing this document. CAS numbers and other limited information are considered proprietary and may not be available for release. **6.** This product is not designed for use in critical life support systems, equipment used in hazardous environments, nuclear control systems or other such applications which necessitate specific safety and regulatory standards other than the ones listed in this datasheet. **7.** Warranty is in accordance with Aimtec's standard Terms of Sale available at www.aimtec.com.