

DIE-CAST ALUMINIUM ENCLOSURES

**SERIES
100**

These designed die-cast aluminium enclosures are ideal for various electronic applications where finish is important.

ALUMINIUM ALLOY

* For sensitive electronic devices. Ideal for pneumatic, hydraulic and electrical applications in industrial and commercial environments. Effective shielding of EMI and RFI is provided.

* Designed to IP65 of IEC529 and NEMA (Dust and hose proof).

* The lid incorporates a recessed neoprene gasket. Wall mounting holes and lid fixing screws are outside the sealing area. Thus the ingress of moisture and dust is prevented.

* Bosses on the internal base are provided for fixing PCB's horizontally.

* The screw holes for mounting of the lid are roll threaded for the counter sunk lid screws.

* Are as standard delivered in natural textured finish but can upon request be supplied black painted or epoxy coated.

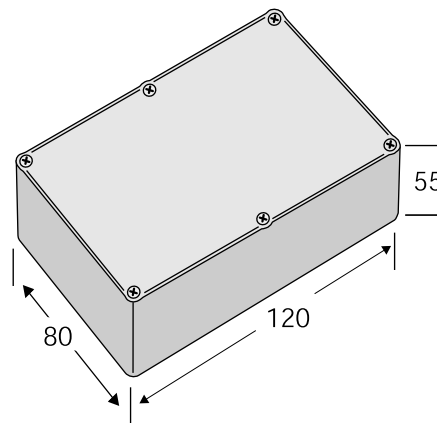
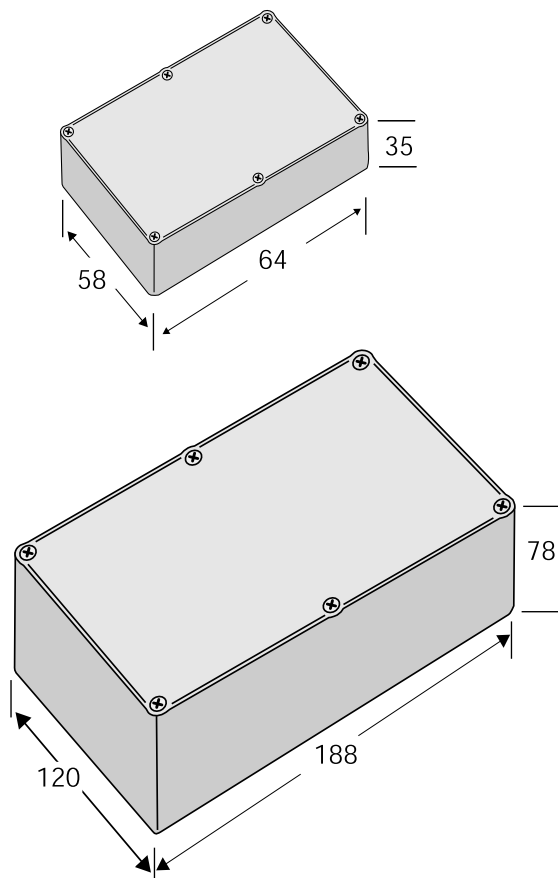
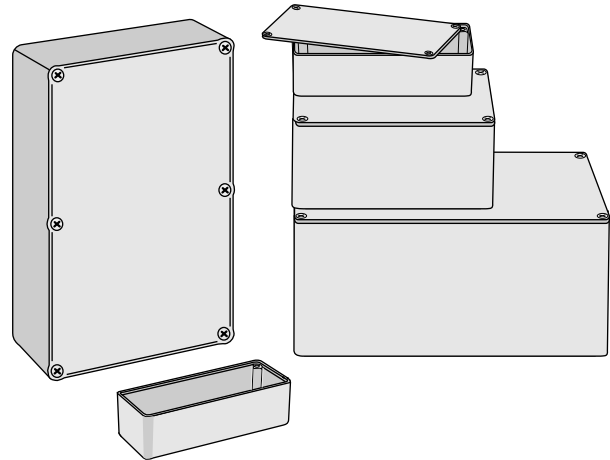

Dimensional information:

STANDARD SEALED

Type	Order code	External dimensions (mm) Width x Depth x Height		
104	p/n 2069104001	64 x	58 x	35
114	p/n 2069114001	80 x	120 x	55
132	p/n 2069132001	120 x	188x	78

● All measurements are in mm.