

Material:

- △ \* Housing : LCP With 35% GF/mineral.  
or Nylon 9T, UL 94V-0 Color Black
- \* Contact: Phosphor Bronze
- \* Pick & Place Pad: High Temperature Plastic

### Ordering Code

CB50 \*\* 2 0 0 T 0  
① ② ③ ④ ⑤ ⑥ ⑦

1. Series No.
2. Contacts: 04~48
3. Plating option :
  - 1= 3.05μm(120μ") Min. Tin plated over 1.27μm(50μ") Nickel
  - 2= 0.05μm(2μ") Min. Gold flash over 1.27μm(50μ") Nickel
  - 3= 0.38μm(15μ") Min. Gold plated over 1.27μm(50μ") Nickel
  - 4= 0.76μm(30μ") Min. Gold plated over 1.27μm(50μ") Nickel
4. 0= Without Peg, P= With Peg
5. 0= Without Pick & Place Pad, P= With Pick & Place Pad
6. Packing: R=Tape & Reel ,T= Tube Packaged
7. Other Option: 0=LCP (Standard), M=Nylon 9T

\* The one with both Peg and Pad is with Tape & Reel packing only.

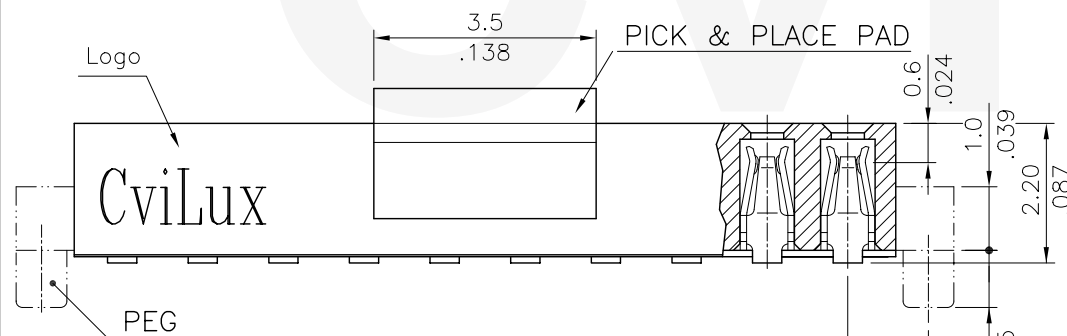
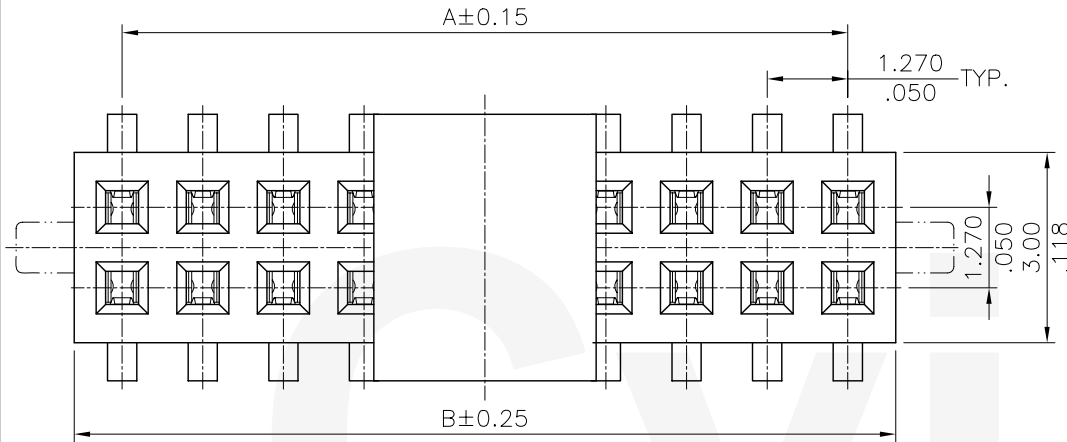

DIM. A = 1.27 X NO. OF SPACES  
DIM. B = DIM. A + 1.67

\* AVAILABLE IN 4 THROUGH 48 CIRCUITS

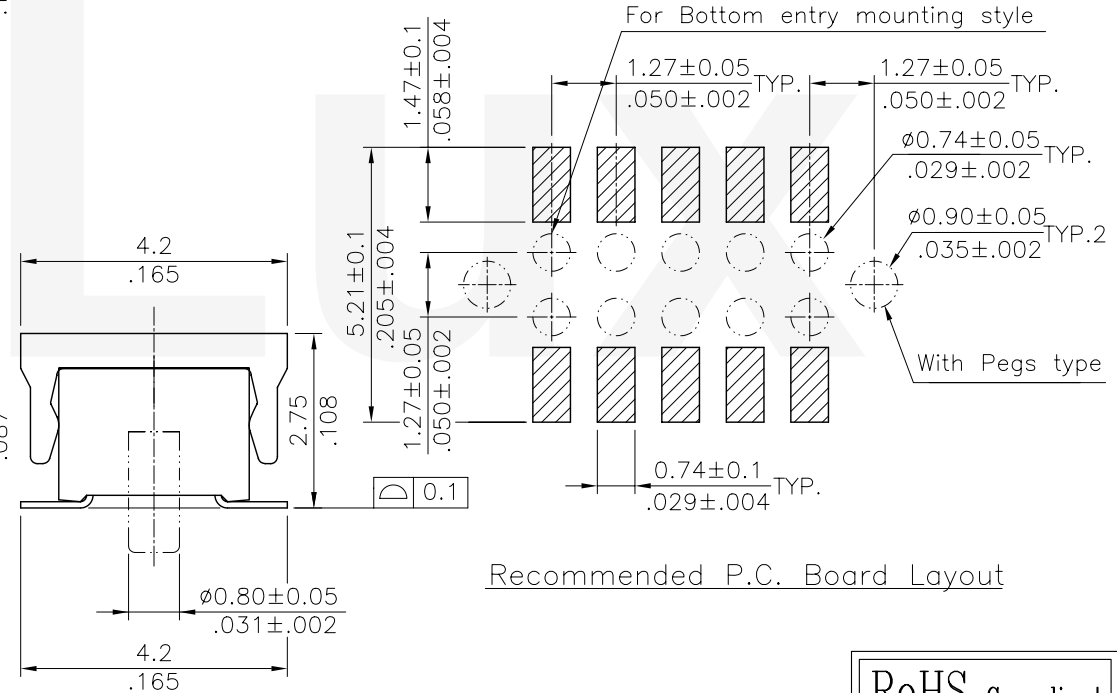

Recommended P.C. Board Layout

RoHS Compliant

△9	Karen	9/21-09'	ECN09465		DATE	UNIT: mm / inch	TITLE: LOW PROFILE 1.27*1.27MM SMT TYPE SOCKET	 瀚荃股份有限公司 CviLux Corporation
△8	Sun	9/30-08'	ECN08113-1/ECN08475	DRAWN BY: Karen	9/21-09'	TOLERANCE UNLESS OTHERWISE SPECIFIED	MATERIAL:	
△7	Sandy	5/28-07'	ECN07188/ECR07023-1	ENGINEER: Easley	9/23-09'	.X ± 0.25/.010 X: ± 1'	FINISH:	DRAWING NO. CB5001SL PART NO. CB50*****
△6	Sandy	4/29-07'	ECN07153	CHECKED BY: David	9/23-09'	.XX ± 0.15/.006 .X: ±		SCALE 8 / 1 SHEET 1 OF 2
SYM	NAME	DATE	REVISIONS	APPROVED BY: Alex	9/23-09'	.XXX ± 0.08/.003 .XX: ±		

CIVILUX CORP  
 2009.09.29  
 ISSUED

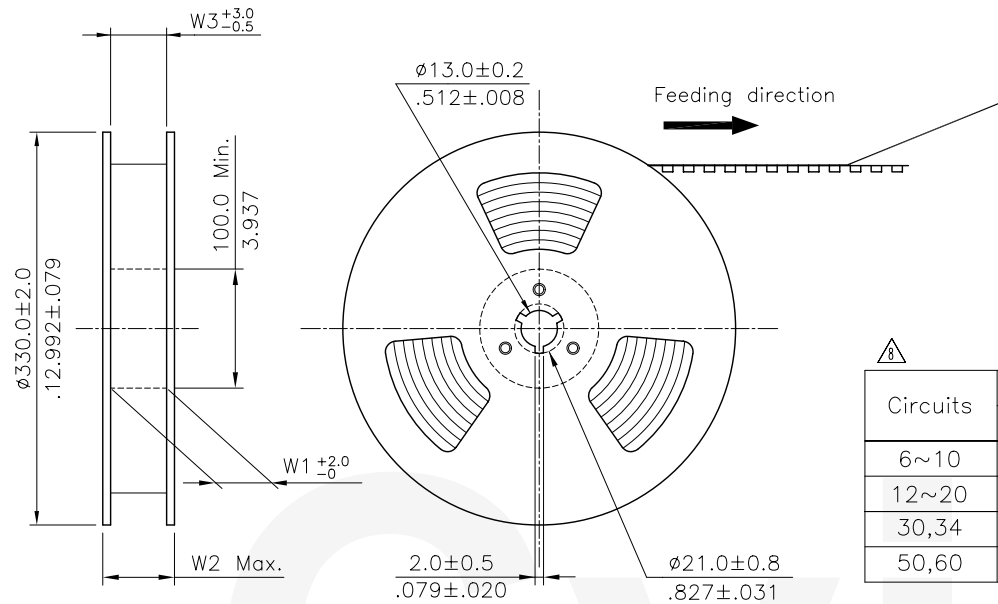

NOTE :

- \* Reel Material : HIPS
- \* Carrier Material : Transparent Conductive Polystyrene Alloy
- \* Cover Tape Material : Polyester
- \* Cover Tape Peel Strength : 0.1N – 1.3N
- \* Carrier camber is within 1mm in 250mm
- \* All dimensions meet EIA-481-B requirements.
- \* Quantity : 2000 PCS/Reel

Circuits	Dimension					Packing (Reel/Caton)
	E	F	W1	W2	W3	
6~10	16.00(.630)	7.50(.295)	16.5(.650)	22.5(.886)	16.5(.650)	11
12~20	24.00(.945)	11.50(.453)	24.5(.965)	30.5(1.201)	24.5(.965)	9
30,34	44.00(1.732)	40.40(1.596)	44.5(1.752)	50.5(1.988)	44.5(1.752)	5
50,60	56.00(2.205)	52.40(2.062)	56.5(2.224)	62.5(2.460)	56.5(2.224)	3

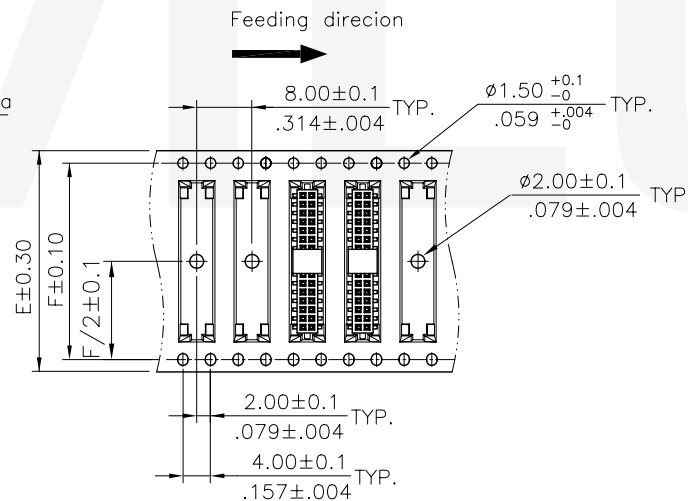
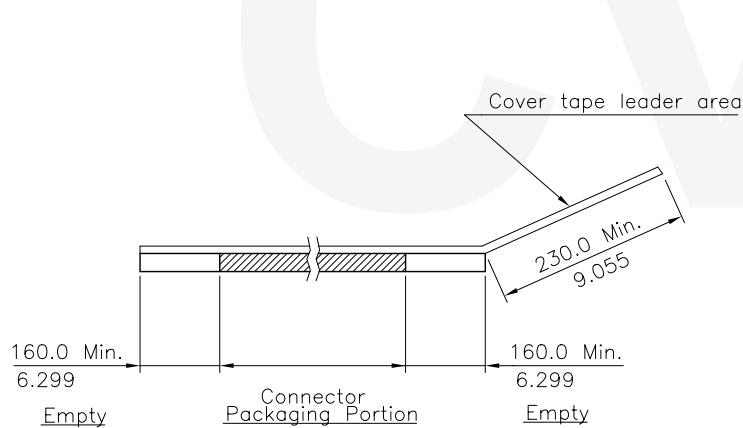

WIDTH : 32.44 mm Carrier

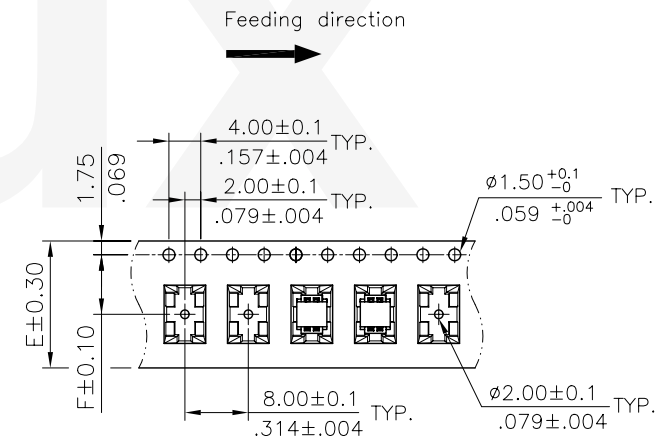

WIDTH : 16.24 mm Carrier

RoHS Compliant

SYM	NAME	DATE	REVISIONS	APPROVED BY:	DATE	UNIT: mm / inch	TITLE: LOW PROFILE 1.27*1.27MM SMT TYPE SOCKET	瀚荃股份有限公司 CviLux Corporation				
9	Karen	9/21-09'	ECN09465					MATERIAL:  FINISH:	DRAWING NO.	CB5001SL	PART NO.	CB50*****
8	Sun	9/30-08'	ECN08113-1/ECN08475	DRAWN BY:	Karen	9/21-09'	TOLERANCE UNLESS OTHERWISE SPECIFIED		SCALE			SHEET 2 OF 2
7	Sandy	5/28-07'	ECN07188/ECR07023-1	ENGINEER:	Eisley	9/23-09'	.X ±      X' ± 1'					
6	Sandy	4/29-07'	ECN07153	CHECKED BY:	David	9/23-09'	.XX ±     X' ±					
				APPROVED BY:	Alex	9/23-09'	.XXX ±    XX' ±					

