

Smartec Pressure Sensor

Features

- * Commercial grade
- * DIP version for high volume production
- * Gauge or absolute pressure
- * Resistive bridge technology
- * Voltage or current excitation

Applications

- * Medical applications
- * Blood pressure
- * Portable Gauges
- * Process control
- * HVAC controls

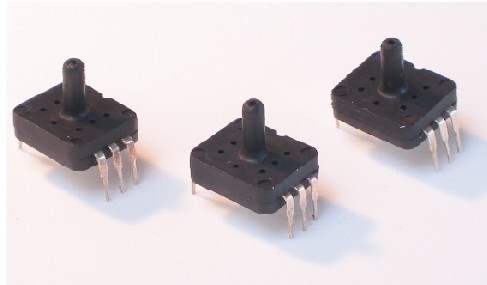

Product description

The Smart Pressure Device SPD series of pressure sensors are silicon based and encapsulated in modified plastic Dual In Line packages, to accommodate six pins for through-board printed circuit mounting.

The sensors come in two distinct types: Gauge and absolute. The gauge type merely measures the pressure with respect to the atmospheric pressure. The absolute type contains a reference vacuum chamber, which is formed on the die during manufacturing.

The output voltages of both types are proportional to the pressure that is measured.

Various pressure ranges are available. On request, other ranges and encapsulations can be supplied. Please contact our sales department for more information.

Because of its bridge resistance value, the SPD pressure sensor is especially suited for use in combination with the Universal Transducer Interface (**UTI03**), which gives an easy and very accurate interface to a digital environment.

SPD bridge series Performance Characteristic

(Measured @5V excitation and 25 °C.)

Parameter	Min	Typ	Max	Units.
Excitation voltage	0	5	10	V
Excitation current		1,5	3	mA
Offset	-50	0	50	mV
Linearity	-0,3	±0,1	0,3	%FS
Bridge Impedance	2.7	3.3	4.0	KΩ
TC Span (0-50 °C)	-27	-22	-17	%FS/100 °C
TC Offset (0-50 °C)	-7		7	%FS/100 °C
TC bridge resistance	23	28	33	%FS/100 °C
Hysteresis			0,15	% of range
Repeatability 1)		±0,2	±0,5	FSO
Response time (10-90%)		1		ms
Pressure overload			1,35	Pa (*10 ⁵)
Operating temperature	-20		85	°C
Storage temperature	-30		125	°C

The below stated differences yield for the SPD005G only

For SPD005G only				
Offset	-20	0	20	mV
Bridge Impedance	4	5	6	KΩ

¹⁾ measured after 1,000 temp. cycles 0 – 70 °C, 10⁶ pressure cycles (10-90% FS)

Type	Range (*10 ⁵ Pa)	Min	Typ(FS)	Max	Unit
005G	0 - 0.350	40	60	80	mV
015G	0 - 1	100	140	175	mV
030G	0 - 2	120	160	200	mV
100G	0 - 6.5	120	190	240	mV

1 Pa = 0.145 · 10⁻³ PSI or 1 PSI = 6.89476 · 10³ Pa

1 Bar = 10⁵ Pa = 10⁵ N/m²

Understanding the specifications

The available range of SPD series pressure sensors allows for a wide range of applications. In order to get good results, it is very important to fully understand the meaning of the various specifications and their effects on accuracy, especially the ones that deal with temperature coefficients. (Silicon resistors are very temperature dependent).

Excitation voltage

The excitation of the sensor can be AC or DC. Specifications are given with a DC excitation of 5V. In order to avoid electrical breakdown it is advised not to exceed the maximum values given.

Offset

The offset value is the electrical output voltage (imbalance) of the pressure sensor when zero pressure is applied. The offset value for the absolute type is determined by extrapolating the measured values at two different pressures (atmospheric air and $0.05 \cdot 10^5$ Pa). The pressure in reference chamber is about 3.33 Pa.

Temperature coefficients

Silicon resistors are very temperature dependent. The overall drift of the resistors is not of interest to most users (The bridge resistors are located on the same die). The temperature coefficients of the offset and span, however, are very important. All the temperature coefficients are given in percentage of full-scale range (FS) and over a temperature range of 100 °C.

The maximum value of the temperature coefficient of the span is minus 27%, which means that worst case the span becomes 27% smaller over the full temperature range of 100 °C. The offset will vary no more than $\pm 7\%$ of the span over the same temperature range. For more about these effects see below “about excitation with voltage or current”.

Calculation example (please refer to the parameter table above)

Suppose the use of a pressure sensor of type SPD 015G over a temperature range of 100 °C. The typical full scale span is 140 mV. The offset (at a fixed temperature) will be between -50 and +50 mV.

Offset

When the static part of the offset has been nulled, the offset can still vary $\pm 7\%$ of 140 mV (± 9.8 mV), over the temperature range of 100°C.

Span

The typical full-scale span is 140 mV and the typical temperature coefficient of the span equals $-22\% \text{FS}/100\text{ °C}$.

Typically, you would therefore have a span, which varies between 140 mV and 109 mV (140 mV minus 22%), over the full temperature range of 100 °C.

In the worst case scenario the minimum value of the span is 100 mV, which means that the sensor has a span of 100 mV, which could drop to 63mV (100 minus 27%) over the full temperature range of 100 °C.

Linearity

The linearity is defined as the maximum deviation from the best fitted straight line.

Interfacing SPD pressure sensors to microcontrollers.

In general this kind of sensors based on Wheatstone bridges has to be connected to microcontrollers. These can be done very easy with the Smartec's Universal Transducer Interface (**UTI**). Below the power of such a UTI system is explained. The list of advantages must be clear to the designer:

- Simple, one chip hardware, just a UTI and the micro
- Thanks to the ratiometric measurement, UTI solution is independent of the supply voltage, so no need for a precise power supply, or to worry about power-supply drift (V_{cc} of UTI is 3 – 5.5 V.)
- AC excitation which means no problems with offset drift of the input amplifier and also AC prevents corrosion effects.
- In combination with the Smartec temperature sensor easy temperature compensation can be realized.

For information and specifications of the UTI please go to the relevant datasheets in the supportshop of our website.

UTI excitation of bridges in voltage or current mode.

All the above given figures are based on excitation with a DC voltage (5 V.) When, due to temperature changes, all of the four resistors change in the same way, this will have no effect on the bridge output voltage. This is valid for the case that the bridge is supplied with voltage.

In the **UTI** we also have a current-mode supply (mode 11 and 12). When one of these modes are applied the conversion of supply current to supply voltage depends on the bridge resistance, and therefore on the resistor temperature coefficient. The current mode is applied to compensate also for another temperature coefficient, which also exist in the voltage mode.

This temperature coefficient is due to the change in the mechanical properties of the membrane of the pressure sensor and of the piezo-resistance effect. So, this figure given in this specification concerns the mechanic cal and the electro-mechanical properties in total.

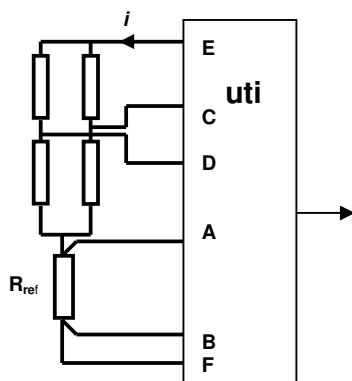

UTI in Current mode(11,12)

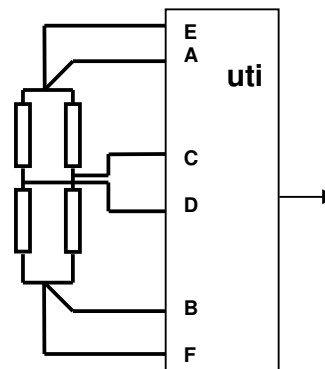

UTI in Voltage mode(9,10)

Outline drawings and dimensions.

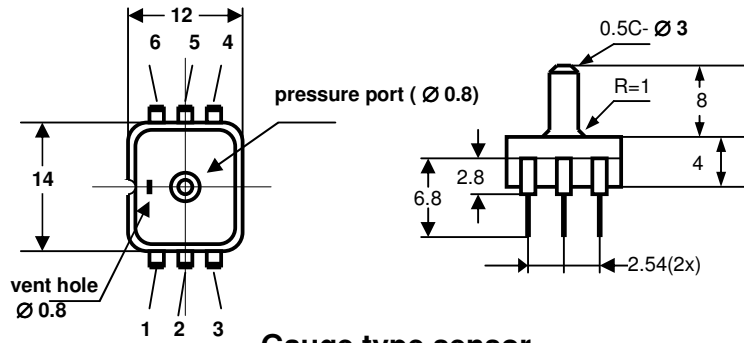

Gauge type sensor

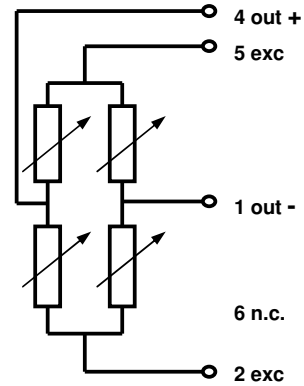

**Connection diagram Gauge type
 (Top View)**

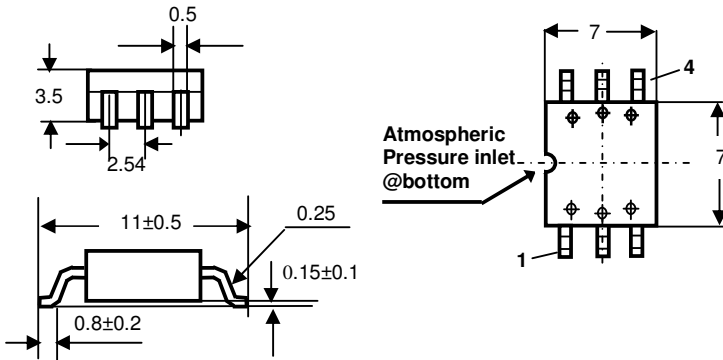

Absolute type sensor

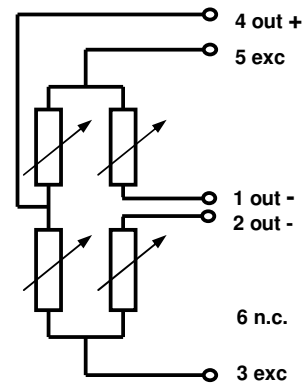

**Connection diagram Absolute type
 (Top View)**

All sizes in mm.

Wetted materials: glass, ryton, silicon, fluorosilicon and gold

Other encapsulations on request.

Ordering information	Part no.	Pressure range
	SPD005G	0 – 0.35 10 ⁵ Pa (Gauge)
	SPD015G	0 – 1.0 10 ⁵ Pa -
	SPD030G	0 – 2.0 10 ⁵ Pa -
	SPD100G	0 – 6.5 10 ⁵ Pa -
	SPD015A	0 – 1.0 10 ⁵ Pa(Absolute)