

公差等级/General Tolerances(mm)		0.1/10	
0	>3	>10	>315
~	~	~	~
3	6	10	30
~	~	~	~
±0.12	±0.18	±0.22	±0.26
±0.31	±0.37	±0.57	±0.80
±1.05	±1.15	±1.60	±2.20
±2.50	±2.50	±2.50	±2.50
±Z	±Z	±Z	±Z

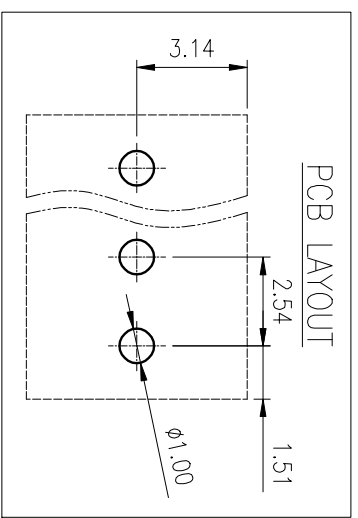
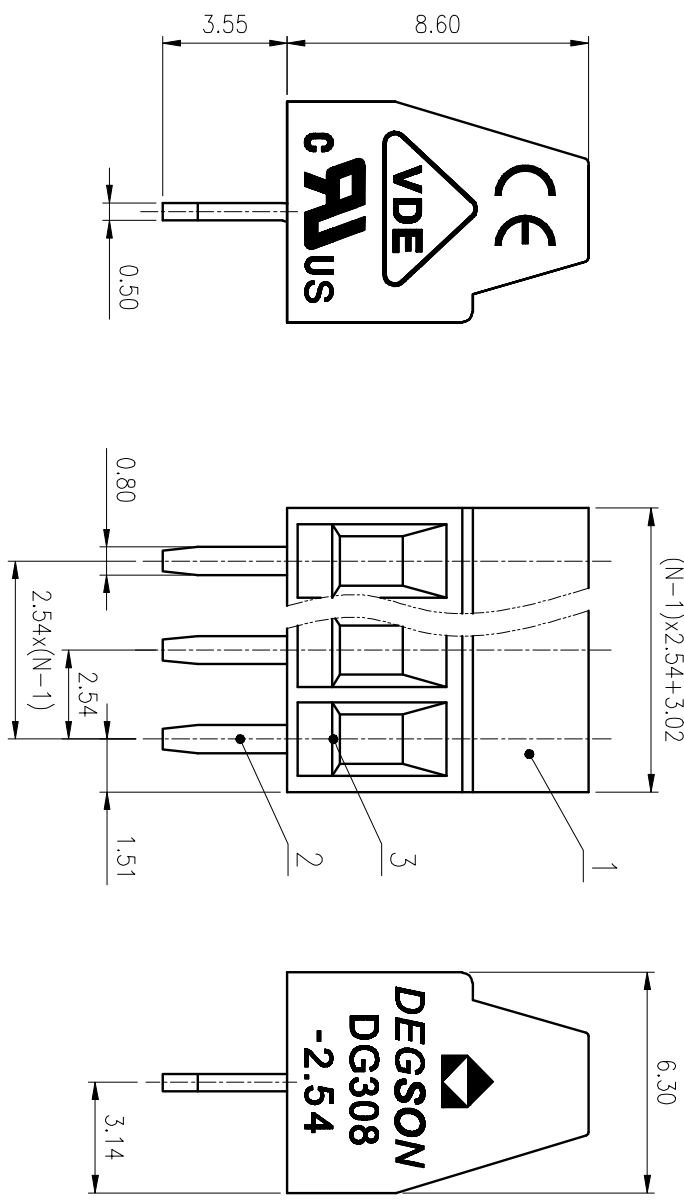
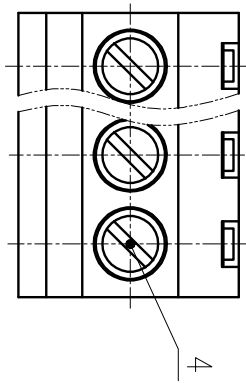

4	Screws	Steel	Ni Plated
3	Cage	Copper alloy	Sn Plated
2	Pin Header	Copper	Sn Plated
1	Housing	PA66	UL94V-0
ITEM	NAME OF PART	MATERIAL	NOTES
UL 标准 / UL Standard:		B	C
额定电压/电涌/Rated Voltage(V)/Current(A)		150/6	/
IEC 标准 / IEC Standard:		/	/
过压类别 / Overvoltage Category / 污染等级 / Pollution Degree		/	III/2
额定电压/电涌/Rated Voltage(V)/Current(A)		/	130/8
工额电压 / Withstanding Voltage(V/Min)		/	AC1250
螺丝扭矩 / Torque Tightening(N·m/Lb.in)		M1.6	0.15/1.29
线径范围 (硬线和软线) / Wire Range(rigid and flexible)(mm ² /AWG)			0.5~1.0/26~18
间距/Pitch(mm) / 线径范围 / Poles			5.00 / N=02~12P
剥线长度 / Stripping length(mm)			4.5
使用温度范围 / Operating Temperature(°C)			-40~+105
符合 RoHS 环保要求 / Conform to RoHS			Yes
标准颜色编号 / Standard color number:			/
PANTONE / RAL			/

MATERIAL:		SURFACE:	
MAT NO.:	/		
STATUS:	/		
APPD:	Li GL 2020.06.15	NAME:	DEGSON [®] NINGBO DEGSON ELECTRICAL CO., LTD
CHKD:	Mao J 2020.06.15	DRAWING NO.:	DG308-C01
DFT:	Wgng LX 2020.06.15	TYPE:	CUSTOMER DRAWING
REV	ECN	DESCRIPTION	DRAFT
DATE	SIZE: A4	SCALE: 5:1	SHEET
1	2	3	4
5	6	1/1	T0

A B C D

1 2 3 4 5 6