

公差 (mm)		公差 (mm)		公差 (mm)		公差 (mm)		公差 (mm)		公差 (mm)		公差 (mm)		公差 (mm)		公差 (mm)	
0	>3	>6	>10	>18	>30	>50	>80	>120	>180	>250	>315	>400	>500	>630	>800	>1000	>1250
±0.12	±0.18	±0.22	±0.26	±0.31	±0.37	±0.57	±0.80	±0.93	±1.05	±1.15	±1.60	±2.20	±2.50	±3.15	±4.00	±5.00	±6.30

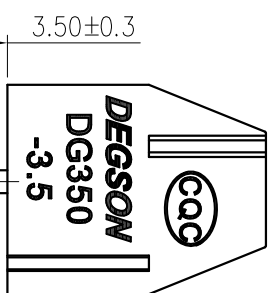
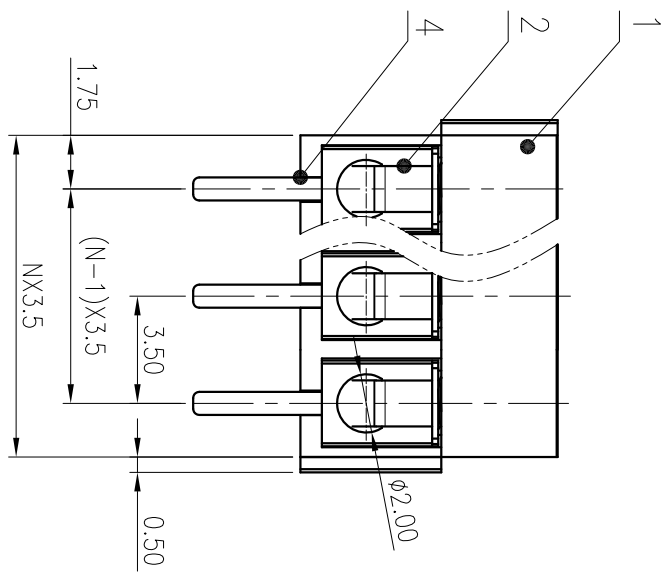
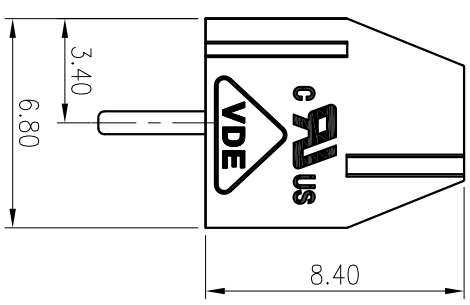
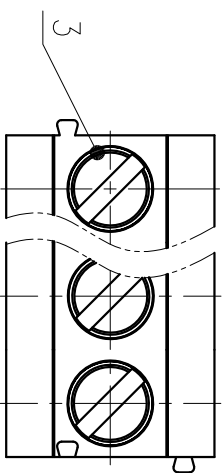

ITEM	NAME OF PART	MATERIAL	NOTES
4	Pin header	Copper alloy	M2/Sn plated
3	Screw	Steel	M2/Zn plated
2	Spring	Stainless steel	/
1	Housing	PA66	UL94V-0

UL 标准/UL Standard:		B	C	D
额定电压/Rated Voltage(V)	Current(A)	300/7	/	/
IEC 标准/IEC Standard:				
过压类别/Overvoltage Category/污染等级		III/3	III/2	II/2
额定电压/电流/Rated Voltage(V)/Current(A)		/	130/10	/
工频耐压/Withstanding voltage(V/1Min)			AC1250	
螺丝扭矩/Torque Tightening(N·m/Lb·in)			M2, 0.20/1.77	
导线范围(硬线和软线)/Wire Range(rigid and flexible)(mm <sup>2</sup> /AWG)			0.5~1.0/24~18	
间距/Pitch(mm)/线数范围/Poles			3.5/N=02~24P	
剥线长度/Stripping length(mm)			5	
使用温度范围/Operating temperature(°C)			-40~+105	
符合RoHS环保要求/Conform to RoHS			Yes	

SURFACE:

MATERIAL:

MAT NO.: /

STATUS: /

APP: Lan CHH 2020.05.20

CHKD: YU JZh 2020.05.20

DFT: Song 2015.12.11

宁波高松电子有限公司  
NINGBO DEGSON ELECTRICAL CO., LTD

NAME: DG350-3.5-XXP-1Y-00A(H)

DRAWING NO.: DG350-3.5-C01

TYPE: CUSTOMER DRAWING

SCALE: 4:1 SHEET 1/1

PCB LAYOUT

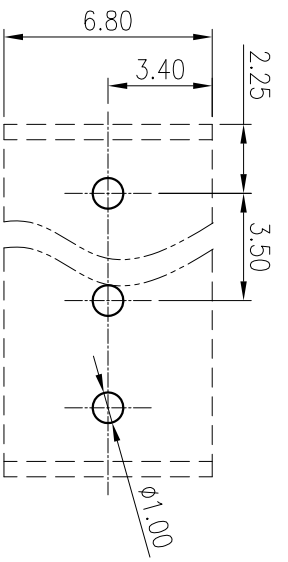

REV	ECN	DESCRIPTION	DFT	DATE