

PCB LAYOUT

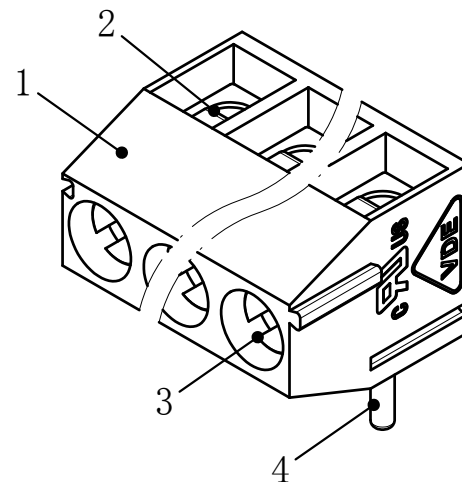
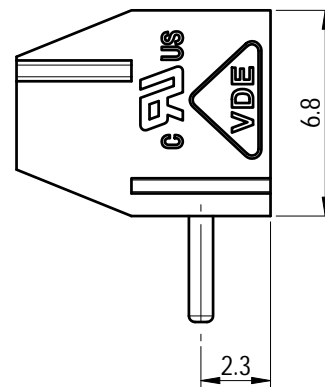
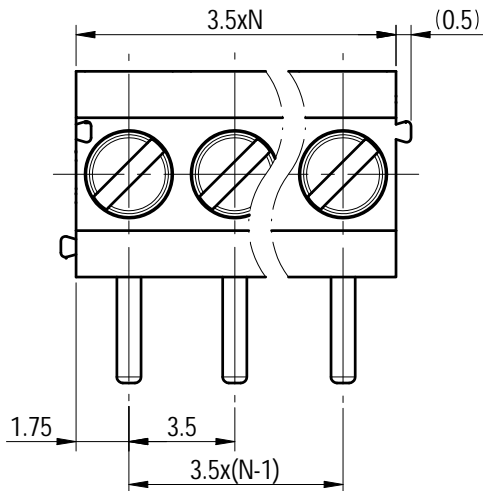
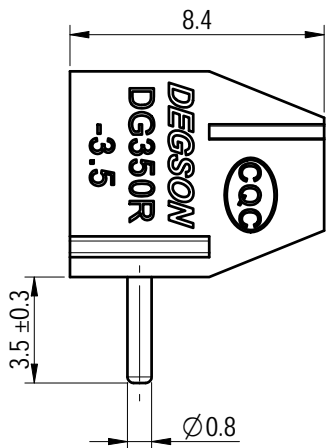
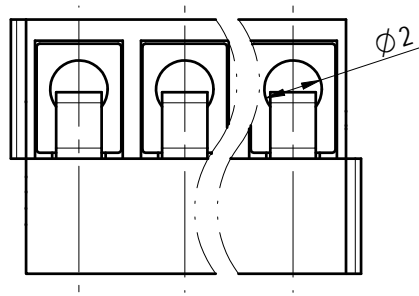
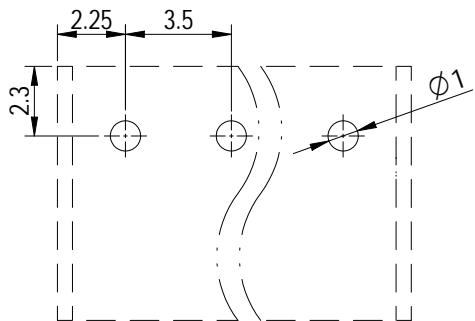

未注公差/General tolerances (mm)													0.1/10	
0	>3	>6	>10	>18	>30	>50	>80	>120	>180	>250	>315	>400		>500
±0.12	±0.18	±0.22	±0.26	±0.31	±0.37	±0.57	±0.80	±0.93	±1.05	±1.15	±1.60	±2.20	±2.50	±2'

UL 标准/UL Standard:	B	C	D
额定电压/电流/Rated Voltage(V)/Current(A)	300/7	/	/
IEC 标准/IEC Standard:			
过压类别/Overvoltage Category/污染等级/Pollution Degree	III/3	III/2	II/2
额定电压/电流/Rated Voltage(V)/Current(A)	/	130/10	/
工频耐压/Withstanding voltage(V/1Min)	/	AC1250	/
螺丝扭矩/Torque Tightening(N·m/Lb.in)	M2, 0.2/1.77		
线径范围(硬线和软线)/Wire Range(rigid and flexible)(AWG/mm²)	24~18 / 0.5~1.0		
间距/Pitch(mm)/线数范围/Poles	3.5/N=02~24P		
剥线长度/Stripping length(mm)	5		
使用温度范围/Operating temperature(°C)	-40~+105		
符合RoHS环保要求/Conform to RoHS	Yes		

Note:
The A&Z(H) in the name means: A(H) and Z(H).

ITEM	NAME OF PART	MATERIAL	NOTES
4	Pin header	Copper alloy	M2/Sn plated
3	Screw	Steel	M2/Zn plated
2	Spring	Stainless steel	/
1	Housing	PA66	UL94V-0

		MATERIAL:	SURFACE/COLOR:		
APPD: 兰春华	2022.10.10	MAT NO./REV: / 00	MAT STATUS: 批量		
CHKD: 陈招	2022.10.10	NAME			
DRFT: 巴字辉	2022.10.10	DG350R-3.5-XXP-1Y-00A&Z(H)			
DRAWING NO. 200111429	TYPE CUSTOMER DRAWING	DRAWING STATUS 已发布	SCALE 4:1	SHEET 1/1	

REV	ECN	DESCRIPTION	DRFT	DATE
00			巴字辉	2022.10.10

Transfer or duplication of this document as well as the utilization or communication of its contents are prohibited unless authorized in writing by DEGSON. All rights reserved for patent. 未经授权，禁止复制或传播本文件内容。保留所有权利，未经许可，不得复制或传播本文件内容。