

公差等级/General	Tolerances(mm)										公差/General			
0	>3	>6	>10	>18	>30	>50	>80	>120	>180	>280	>315	>400	0.1/10	
3	~	~	~	~	~	~	~	~	~	~	~	~	±Z	
6	±0.12	±0.18	±0.22	±0.26	±0.31	±0.37	±0.57	±0.80	±0.93	±1.05	±1.15	±1.60	±2.20	±2.50

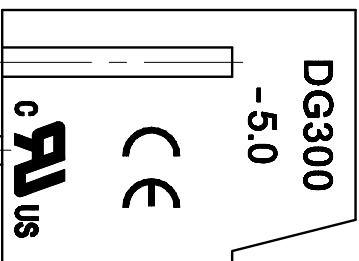
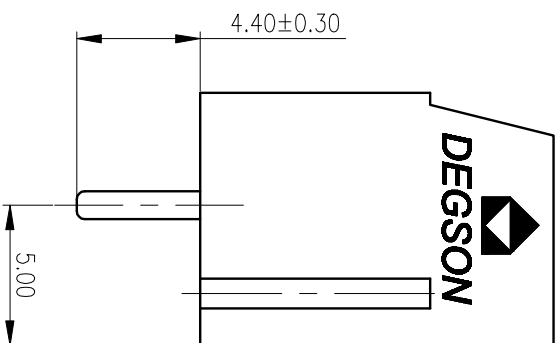
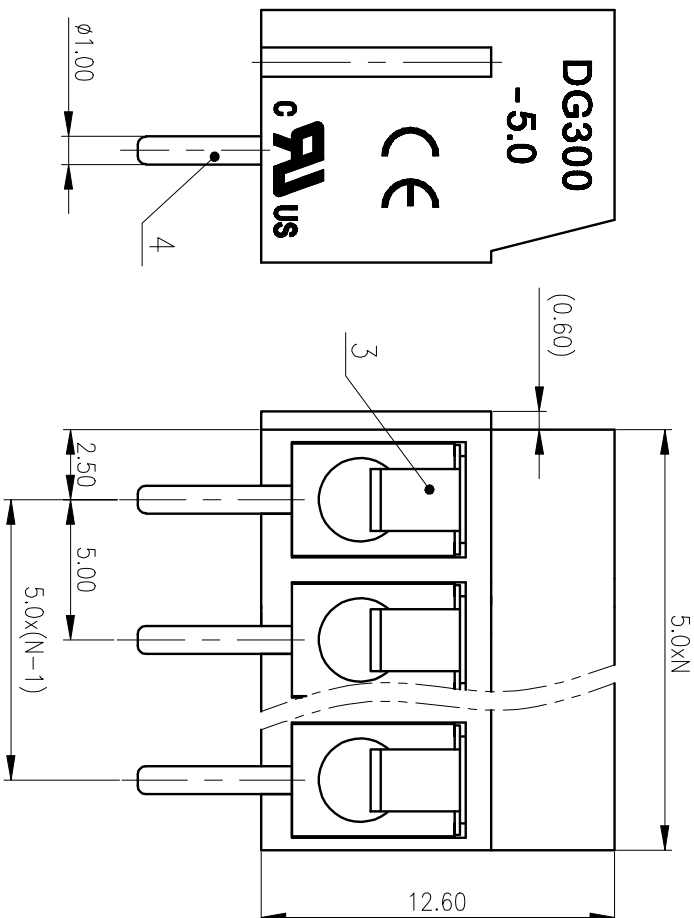

ITEM	NAME OF PART	MATERIAL	NOTES
4	Pin header	Copper alloy	M3/Sn Plated
3	Spring	Stainless steel	
2	Screw	Steel	M3/Zn Plated
1	Housing	PBT	UL94V-0

UL 标准/UL Standard:	B	C	D
额定电压/电涌/Rated Voltage(V)/Current(A)	300/10	/	300/10
IEC 标准/IEC Standard:			
过压类别/Overvoltage Category/污染等级/Pollution Degree	III/3	III/2	II/2
额定电压/电涌/Rated Voltage(V)/Current(A)	/	250/24	/
工频耐压/Withstanding voltage(V/1Min)		AC2000	
拧紧扭矩/Torque Tightening(N·m/Lb.in)		M3, 0.29/2.60	
线径范围(硬线和软线)/Wire Range(rigid and flexible)(mm ² /AWG)		1.0~2.5/22~14	
间距/Pitch(mm)/线数范围/Poles		5.0/N=02~24P	
剥线长度/Stripping length(mm)		5~6	
使用温度范围/Operating temperature(°C)		-30~+120	
符合RoHS环保要求/Conform to RoHS		Yes	

MATERIAL: SURFACE:

MAT NO.: /
 STATUS: /
 APPD: Lon CHH 2020.05.25
 CHKD: Yu JZh 2020.05.25
 DRAFT: Li Zh 2020.05.25

NAME: **DEGSON® NINGBO DEGSON ELECTRICAL CO., LTD**
DG300-5.0-XXP-1Y-00A(H)

DRAWING NO.: 10002155

REV	ECN	DESCRIPTION	DRAFT	DATE	TYPE	SCALE	SHEET
1					CUSTOMER DRAWING	4:1	1/1

D C B A

1 2 3 4 5 6