

公差表/General tolerances(mm)		0	>3	>6	>10	>18	>30	>50	>80	>120	>180	>250	>315	>400	>500	0.1/1.0
~	~	~	~	~	~	~	~	~	~	~	~	~	~	~	~	±
±0.12	±0.18	±0.22	±0.26	±0.31	±0.37	±0.42	±0.48	±0.57	±0.68	±0.80	±0.93	±1.05	±1.15	±1.60	±2.20	±2.50

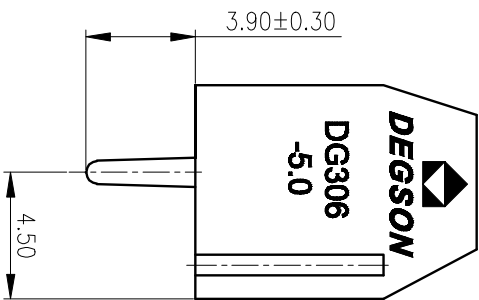
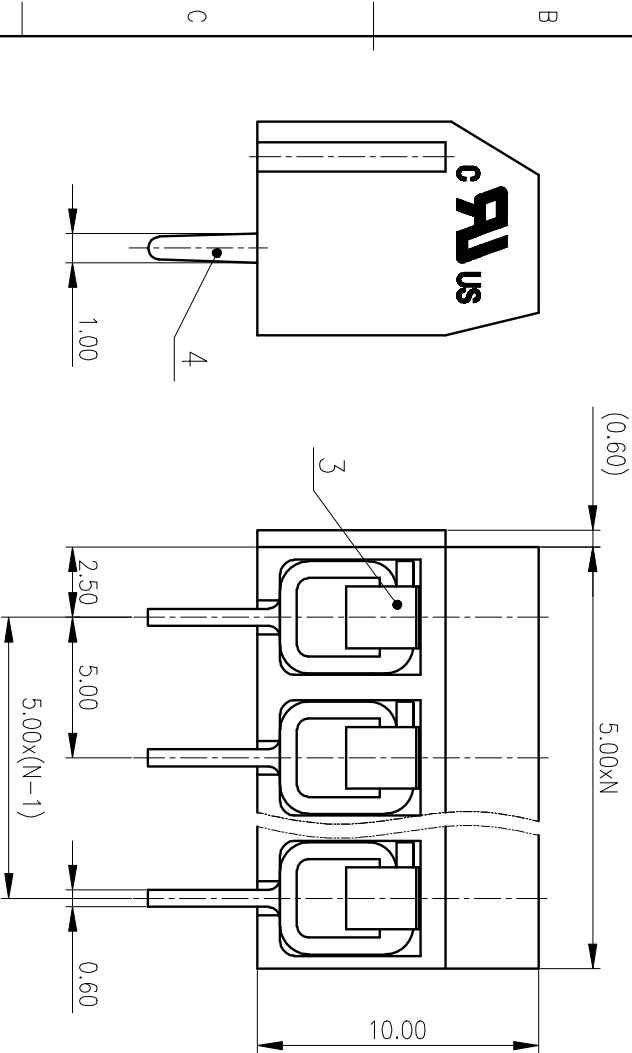
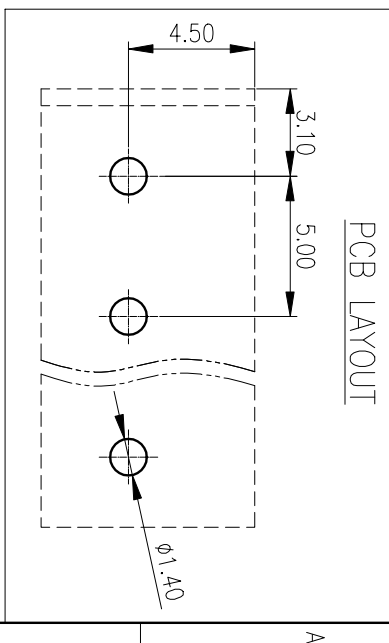
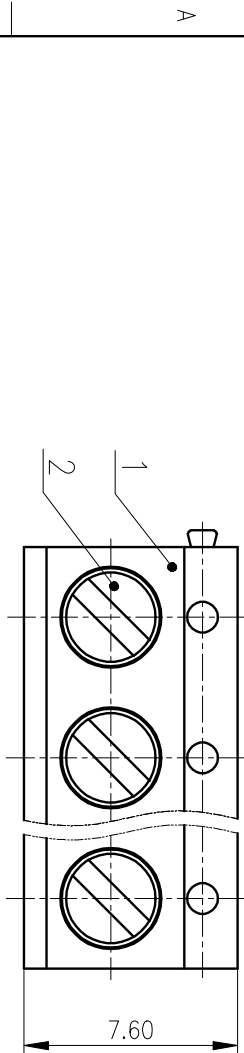

4	Pin header	Copper alloy	M2.5/Sn Plated
3	Spring	Stainless steel	
2	Screw	Steel	M2.5/Zn Plated
1	Housing	PBT	UL94V-0
ITEM	NAME OF PART	MATERIAL	NOTES

UL 标准/UL Standard:	B	C	D
额定电压/额定 Voltage(V)/Current(A)	300/10	/	/
EC 标准/EC Standard:			
过压类别/Overvoltage Category/污染等级	III/3	III/2	II/2
绝缘等级/Insulation Degree	/	250/15	/
额定电压/额定 Voltage(V)/Current(A)	/	AC2000	/
工频耐压/Withstanding voltage(V/1Min)	/	M2.5, 0.29/2.60	/
拧紧扭矩/Torque Tightening(N·m/Lbin)	/	0.75~1.5/22~14	/
线径范围(硬线和软线)/Wire Range(rigid and flexible)(mm ² /AWG)	/	5.0/N=02~24P	/
间距/Pitch(mm)/线数范围/Poles	/	5~6	/
引线长度/Stripping length(mm)	/	-30~+120	/
使用温度范围/Operating temperature(°C)	/	Yes	/
符合RoHS环保要求/Conform to RoHS	/		/

MATERIAL: SURFACE: Yes

MAT NO.: /
 STATUS: /
 APPD: Lan CHH 2020.05.25
 CHKD: Yu JZh 2020.05.25
 DRT: BYH 2019.01.12

NAME: **DEGSON® NINGBO DEGSON ELECTRICAL CO., LTD**
DG306-5.0-XXP-1Y-00A(H)

DRAWING NO.: DG306-5.0-C06
 TYPE: CUSTOMER DRAWING
 SCALE: 4:1
 SHEET 1/1

REV	ECN	DESCRIPTION	DRT	DATE
1				
2				
3				
4				