

公差等级/General Tolerances(mm)		公差等级/General Tolerances(mm)										公差等级/General Tolerances(mm)		
0	>3	>6	>10	>18	>30	>50	>80	>120	>180	>250	>315	>400	>500	0.1/10
~	~	~	~	~	~	~	~	~	~	~	~	~	~	±Z
+0.12	+0.18	+0.22	+0.26	+0.31	+0.37	+0.57	+0.80	+1.05	+1.15	+1.60	+2.20	+2.50		

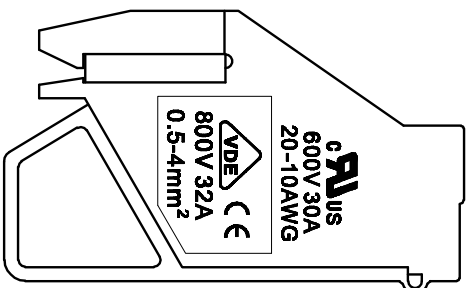
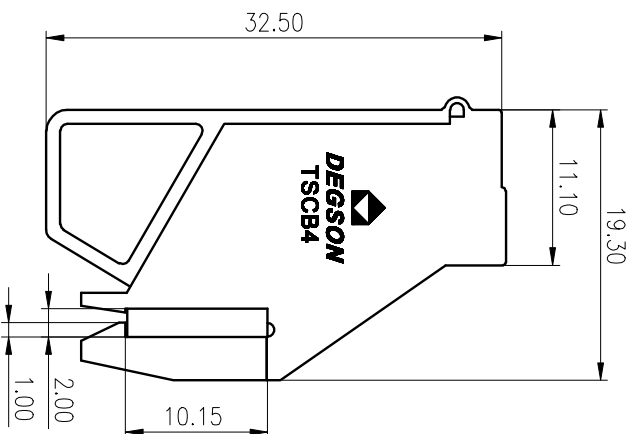
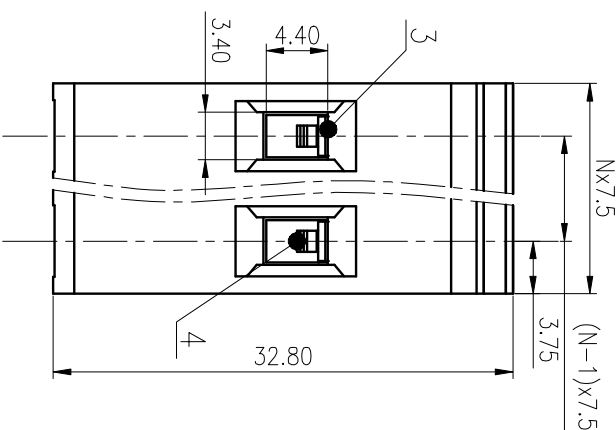
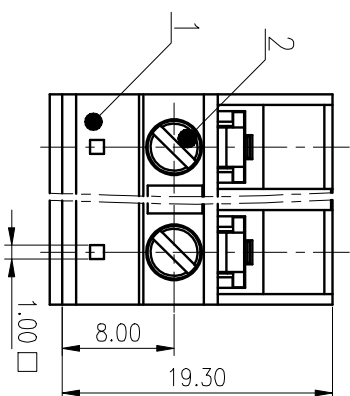

ITEM	NAME OF PART	MATERIAL	NOTES
4	Pin	Copper	Sn Plated
3	Cage	Copper alloy	M3/Ni Plated
2	Screw	Copper alloy	M3/Ni Plated
1	Housing	PA66	UL94V-0

UL 标准/UL Standard:		B	C	D
额定电压/Rated Voltage(V)	Current(A)	600/30	600/30	600/5
IEC 标准/IEC Standard:				
额定电压/Rated Voltage(V)	Current(A)	III/2		
过压类别/Overvoltage Category/特殊等级/ Pollution Degree				
额定电压/电压/Rated Voltage(V)	Current(A)	800/32		
工频耐压/Withstanding voltage		AC2500V/1min		
螺丝扭矩/Torque Tightening(N·m/Lb.in)		M3: 0.5/4.43		
线径范围/Wire Range(mm²/AWG)		0.5~4 / 20~10		
间距/Pitch(mm)/线数/极数/Poles		7.50/N=01~03P		
剥线长度/Stripping length(mm)		10~12		
使用温度范围/Operating temperature(°C)		-40~+105		
符合RoHS环保要求/Conform to RoHS		Yes		
标准颜色编号/Standard color number: RAL		RAL 2000		

MATERIAL:

SURFACE:

MAT NO.:

STATUS:

APPD:

CHKD:

DRT:

DEGSON® 宁波高松电子有限公司
NINGBO DEGSON ELECTRICAL CO., LTD

NAME: TSCB4-XXP-15-01A(H)

DRAWING NO.: TSCB4-C02

TYPE: CUSTOMER DRAWING

REV	ECN	DESCRIPTION	DRT	DATE	SIZE: A4	SCALE: 2:1	SHEET
							1/1

D

C

B

A

D

C

B

A

1

2

3

4

5

6