

## *Data Sheet*

Customer: \_\_\_\_\_

Product: Multilayer Chip Ceramic Capacitor - C Series

Size : 0402/0603/0805/1206/1210/1808/1812/1825/2220/2255

Issued Date: 10-May..-2022

Edition: Ver. 9

### Record of change

Date	Ver.	Description	Page
30-Oct.-2014	1		
05-Oct-2015	2	Revised storage condition	21
20-Feb.-2016	3	Revised capacitance range and thickness Delete size 2211	4 ~ 13
23-Apr.-2016	4	Add PCB land pattern recommendation	27
16-SEP.-2020	5	0805N103J500 T:0.85mm/1.25mm	5
16-Jul.-2021	6	1210B105K500 T:1.65mm/1.25mm	9
27-Oct-2021	7	Add 1206 154/224 200/250 V	10
10-Dec-2021	8	Add 1210 106K 100V X7R, Y5V EOL	10, 13
10-May-2022	9	Revised C >10UF Freq.	15

### **HITANO ENTERPRISE CORP.**

7F-7, No. 3, Wu Chuan 1<sup>st</sup> Road, New Taipei Industrial Park,  
New Taipei City, TAIWAN, R.O.C.

Tel: +886 2 2299 1331 (Rep.)

Fax: +886 2 2298 2466, 2298 2969

Prepared by	Checked by	Approved by	Accepted by (customer)
10-Dec-2021	10-Dec-2021	10-Dec-2021	
<i>Andy Hsu</i>	<i>Hwa Wu</i>	<i>Hwa Wu</i>	

<b>Introduction</b>	<b>2</b>
<b>Part Number Code</b>	<b>3</b>
<b>Capacitance Range – NPO</b>	<b>4-7</b>
<b>Capacitance Range – X7R/X5R</b>	<b>8-12</b>
<b>Thickness Code &amp; SPQ</b>	<b>13</b>
<b>Specifications and Test Methods</b>	<b>14-17</b>
<b>Packing</b>	<b>18-21</b>
<b>Soldering &amp; Cleaning</b>	<b>22</b>
<b>Storage and Label</b>	<b>23</b>
<b>PCB Design</b>	<b>24-26</b>

## 1. Features

Various temperature characteristics cover a wide range in small size.  
Mounted either by flow or reflow soldering methods  
Excellent dielectric strength due to uniform structure of dielectric layers

## 2. Applications

MLCC are becoming increasingly important key electronic applications, which are helpful in reducing the size of electronic circuitry. MLCC are used extensively in computers, communicative products, and the detail applications which including the followings:  
Discharge of Stored Energy  
Blockage of Direct Current  
Coupling of Circuit Components  
By-Passing of an AC Signal  
Frequency Discrimination  
Transient Voltage and Arc Suppression  
Surge Protection

## 3. Construction of MLCC

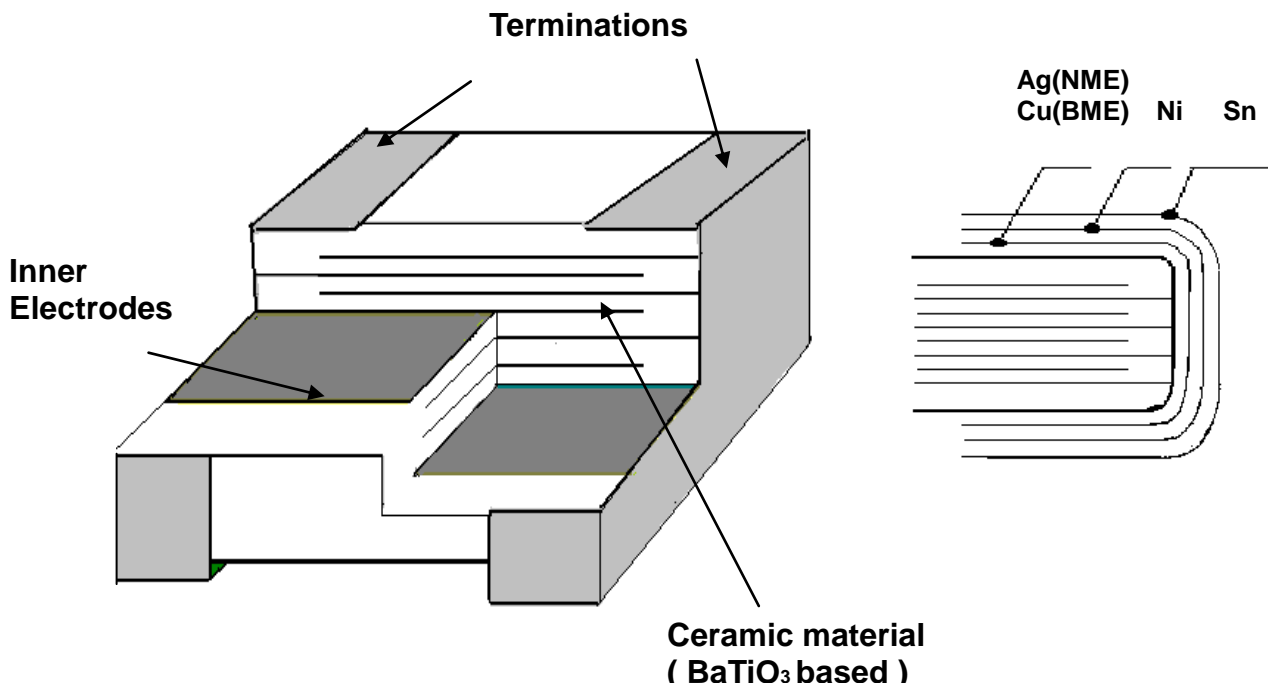

**Part Numbering**

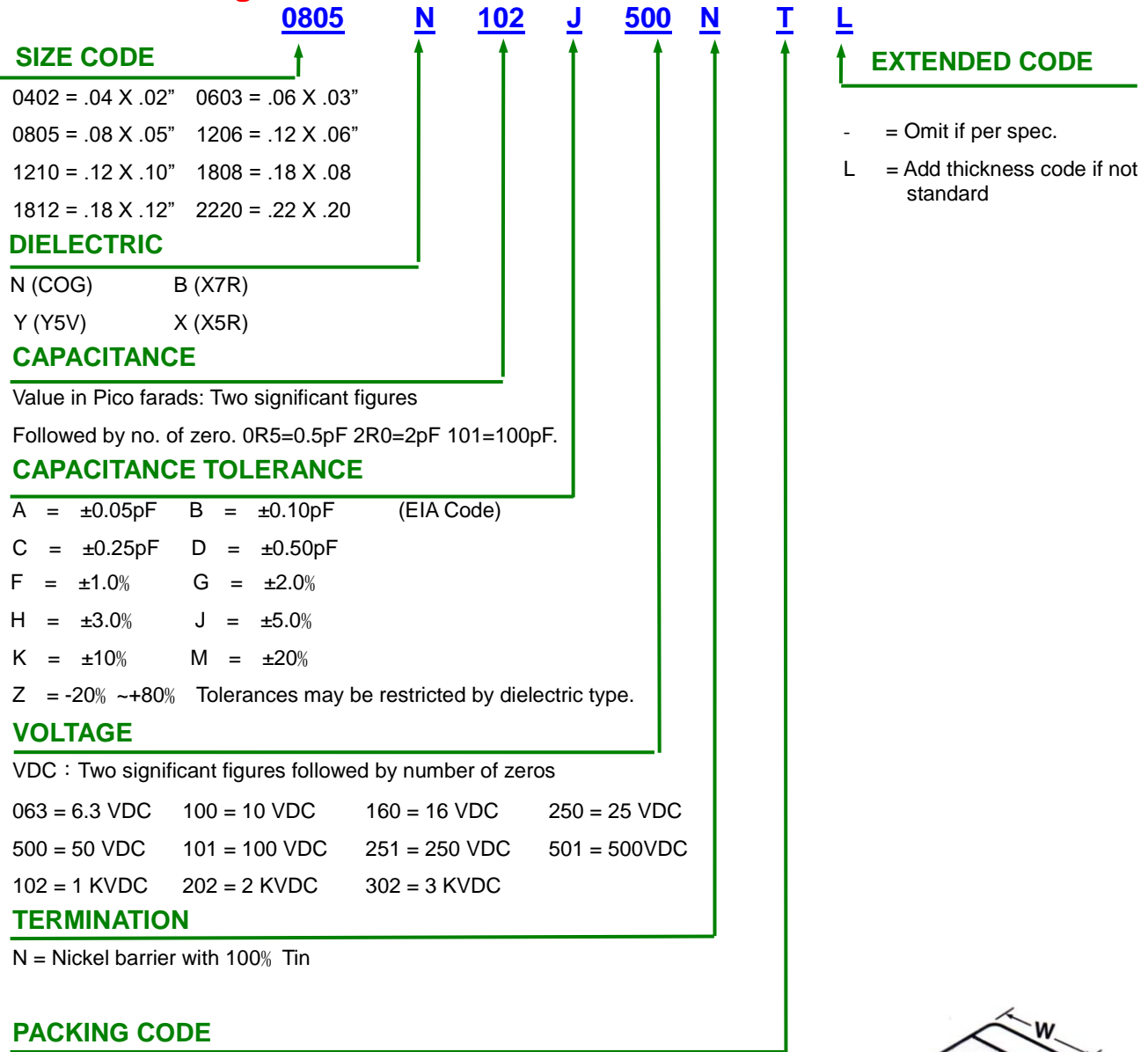

- = Omit if per spec.  
L = Add thickness code if not standard

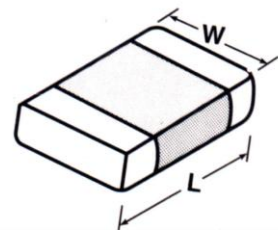

**Dimension : (UNIT mm)**

	0402	0603	0805	1206	1210	1808	1812	1825	2220	2225
L	1.00±0.05	1.60±0.10	2.00±0.20	3.20±0.20	3.20±0.30	4.50±0.30	4.50±0.30	4.50±0.30	5.70±0.40	5.70±0.40
W	0.50±0.05	0.80±0.10	1.25±0.20	1.60±0.20	2.50±0.20	2.00±0.20	3.20±0.30	6.30±0.40	5.00±0.40	6.30±0.40



## Size and capacitance range NPO 100V ~ 630V (Medium Voltage)

Size		0402			0603			0805					1206					1210					1812				
(L)	mm	1.00±0.05			1.60±0.10			2.00±0.20					3.20±0.20					3.20±0.30					4.50±0.30				
(W)	mm	0.50±0.05			0.80±0.10			1.25±0.20					1.60±0.20					2.50±0.20					3.20±0.30				
(T)	mm	0.50±0.05			0.80±0.10			1.25±0.10					1.65±0.20					2.50±0.30					3.00±0.30				
(t)	mm	0.15±0.03			0.27~0.60			0.30~0.70					0.30~0.70					0.30~0.70					0.35~1.00				
Cap./ W.V.		100	100	200	250	100	200	250	500	630	100	200	250	500	630	100	200	250	500	630	100	200	250	500	630		
1 - 8.2	pF	S	P	P	P	A	A	A	A	A	H	H	H	H	H												
10-68	pF	S	P	P	P	A	A	A	A	A	H	H	H	H	H	C	C	C	C	C	C	X	X	X	X	X	
82	pF	S	P	P	P	A	A	A	H	H	H	H	H	H	H	C	C	C	C	C	C	X	X	X	X	X	
100	pF	S	P	P	P	A	A	H	H	H	H	H	H	H	H	C	C	C	C	C	C	X	X	X	X	X	
120	pF	S	P	P	P	A	A	H	X	X	H	H	H	H	H	C	C	C	C	C	C	X	X	X	X	X	
150	pF	S	P	P	P	A	H	H	X	X	H	H	H	H	H	C	C	C	C	C	C	X	X	X	X	X	
180	pF	S	P	P	P	A	H	X	X	X	H	H	H	H	H	C	C	C	C	C	C	X	X	X	X	X	
220	pF	S	P	P	P	A	X	X	X	X	H	H	H	H	H	C	C	C	C	C	C	X	X	X	X	X	
270	pF		P	P	P	A	X	X	X	X	H	H	C	C	C	C	C	C	C	C	C	X	X	X	X	X	
330	pF		P	P	P	A	X	X	X	X	H	H	C	C	C	C	C	C	C	C	C	X	X	X	X	X	
390	pF		P	P	P	H	X	X	X	X	H	H	C	C	C	C	C	C	C	C	C	X	X	X	X	X	
470	pF		P	P	P	H	X	X	X	X	H	C	C	C	C	C	C	C	C	C	C	X	X	X	X	X	
560	pF		P	P	P	H	X	X	X	X	H	C	X	X	X	C	C	C	C	C	C	X	X	X	X	X	
680	pF		P	P	P	H	X	X	X	X	H	C	X	X	X	C	C	C	C	C	C	X	X	X	X	X	
820	pF		P	P	P	H	X	X	X	X	H	C	L	L	L	C	C	C	C	C	C	X	X	X	X	X	
1000	pF		P			H	X	X	X	X	H	C	L	L	L	C	X	X	X	X	X	X	X	X	X	X	
1200	pF		P			H	X	X	X	X	H	C	L	L	L	C	X	X	X	X	X	X	X	X	X	X	
1500	pF		P			H	X	X	X	X	H	X	L	L	L	C	X	X	X	X	X	X	X	X	X	X	
1800	pF					H	X	X	X	X	H	X	L	L	L	C	X	X	X	X	X	X	X	X	X	X	
2200	pF					H	X	X	X	X	H	X	L	L	L	C	X	X	X	X	X	X	X	X	X	X	
2700	pF					X					H	X	L	L	L	C	X	X	X	X	X	X	X	X	X	X	
3300	pF					X					H	X	L	L	L	C	X	X	X	X	X	X	X	X	X	X	
3900	pF					X					H	L	L	L	L	C	X	X	X	X	X	X	X	X	X	X	
4700	pF					X					H	L	L	L	L	X	X	X	X	X	X	X	X	X	X	X	
5600	pF					X					H	L	L	L	L	X	X	X	X	X	X	X	X	X	X	X	
6800	pF					X					C	L	L			L	L	L	L	L	L	X	X	X	X	X	
8200	pF										X	L	L			L	L	L	L	L	L	X	X	X	X	X	
10	nF										X					L	Z	Z	Z	Z	Z	X	X	X	X	X	
12	nF										L					L	Z	Z	Z	Z	Z	X	L	L	L	L	
15	nF										L					Z	G	G	G	G	G	X	L	L	L	L	
18	nF										L					G	G	G				L	Z	Z	Z	Z	
22	nF										L					G	G	G				L	Z	Z	Z	Z	
27	nF																					Z	G	G	G	G	
33	nF															G						Z	G	G	G	G	
39	nF																					G	G	G			
47	nF																					G	G	G			
56	nF																					G					
68	nF																					G					

Remark: Customized size and specification is available upon request. Please contact us for further details

**Size and capacitance range NPO 100V ~ 630V (Medium Voltage)**

Size		1825					2220					2225				
(L)	mm	4.50±0.30					5.70±0.40					5.70±0.40				
(W)	mm	6.30±0.40					5.00±0.40					6.30±0.40				
(T)	mm	2.50±0.30					3.00±0.20					3.00±0.20				
(t)	mm	0.35~1.00					0.35~1.00					0.35~1.00				
Cap. \ W.V		100	200	250	500	630	100	200	250	500	630	100	200	250	500	630
10	pF	L	L	L	L	L	L	L	L	L	L	L	L	L	L	L
12	pF	L	L	L	L	L	L	L	L	L	L	L	L	L	L	L
15	pF	L	L	L	L	L	L	L	L	L	L	L	L	L	L	L
18	pF	L	L	L	L	L	L	L	L	L	L	L	L	L	L	L
22	pF	L	L	L	L	L	L	L	L	L	L	L	L	L	L	L
27	pF	L	L	L	L	L	L	L	L	L	L	L	L	L	L	L
33	pF	L	L	L	L	L	L	L	L	L	L	L	L	L	L	L
39	pF	L	L	L	L	L	L	L	L	L	L	L	L	L	L	L
47	pF	L	L	L	L	L	L	L	L	L	L	L	L	L	L	L
56	pF	L	L	L	L	L	L	L	L	L	L	L	L	L	L	L
68	pF	L	L	L	L	L	L	L	L	L	L	L	L	L	L	L
82	pF	L	L	L	L	L	L	L	L	L	L	L	L	L	L	L
100	pF	L	L	L	L	L	L	L	L	L	L	L	L	L	L	L
120	pF	L	L	L	L	L	L	L	L	L	L	L	L	L	L	L
150	pF	L	L	L	L	L	L	L	L	L	L	L	L	L	L	L
180	pF	L	L	L	L	L	L	L	L	L	L	L	L	L	L	L
220	pF	L	L	L	L	L	L	L	L	L	L	L	L	L	L	L
270	pF	L	L	L	L	L	L	L	L	L	L	L	L	L	L	L
330	pF	L	L	L	L	L	L	L	L	L	L	L	L	L	L	L
390	pF	L	L	L	L	L	L	L	L	L	L	L	L	L	L	L
470	pF	L	L	L	L	L	L	L	L	L	L	L	L	L	L	L
560	pF	L	L	L	L	L	L	L	L	L	L	L	L	L	L	L
680	pF	L	L	L	L	L	L	L	L	L	L	L	L	L	L	L
820	pF	L	L	L	L	L	L	L	L	L	L	L	L	L	L	L
1000	pF	L	L	L	L	L	L	L	L	L	L	L	L	L	L	L
1200	pF	L	L	L	L	L	L	L	L	L	L	L	L	L	L	L
1500	pF	L	L	L	L	L	L	L	L	L	L	L	L	L	L	L
1800	pF	L	L	L	L	L	L	L	L	L	L	L	L	L	L	L
2200	pF	L	L	L	L	L	L	L	L	L	L	L	L	L	L	L
2700	pF	L	L	L	L	L	L	L	L	L	L	L	L	L	L	L
3300	pF	L	L	L	L	L	L	L	L	L	L	L	L	L	L	L
3900	pF	L	L	L	L	L	L	L	L	L	L	L	L	L	L	L
4700	pF	L	L	L	L	L	L	L	L	L	L	L	L	L	L	L
5600	pF	L	L	L	L	L	L	L	L	L	L	L	L	L	L	L
6800	pF	L	L	L	L	L	L	L	L	L	L	L	L	L	L	L
10000	pF	L	L	L	L	L	L	L	L	L	L	L	L	L	L	L
12000	pF	L	L	L	L	L	L	L	L	L	L	L	L	L	L	L
15000	pF	L	L	L	L	L	L	L	L	L	L	L	L	L	L	L
18000	pF	L	L	L	L	L	L	L	L	L	L	L	L	L	L	L
22000	pF	L	L	L	L	L	L	L	L	L	L	L	L	L	L	L
27000	pF	L	L	L	Z	Z	L	L	L	Z	Z	L	L	L	L	L
33000	pF	L	L	L	Z	Z	L	Z	Z	Z	Z	L	L	L	L	L
39000	pF	L	Z	Z	G	G	L	Z	Z	G	G	L	Z	Z	Z	Z
47000	pF	L	Z	Z	G	G	L	G	G	G	G	L	Z	Z	Z	Z
56000	pF	Z	G	G	G	G	Z	G	G	G	G	L	G	G	G	G
68000	pF	Z	G	G	G	G	Z	G	G			Z	G	G	G	G
82000	pF	G	G	G			G	G	G			Z	G	G	G	G
100000	pF	G					G					G	G	G		

**Size and capacitance range NPO 1000V ~ 4000V (High Voltage)**

Size		0805	1206			1210			1808				1812				1825				2220				2225			
(L)	mm	2.10±0.20	3.30±0.30			3.30±0.40			4.60±0.40				4.60±0.30				4.50±0.30				5.70±0.40				5.70±0.40			
(W)	mm	1.25±0.20	1.60±0.20			2.50±0.20			2.00±0.25				3.20±0.40				6.30±0.40				5.00±0.40				6.30±0.40			
(T)	mm	1.25±0.10	1.65±0.20			2.50±0.30			2.00±0.20				3.00±0.30				2.50±0.30				3.00±0.20				3.00±0.20			
(t)	mm	0.30~0.70	0.40~0.80			0.40~1.10			0.40~1.10				0.4~1.10				0.4~1.10				0.4~1.10				0.4~1.10			
Cap./ W.V.		1K	1K	2K	3K	1K	2K	3K	1K	2K	3K	4K	1K	2K	3K	4K	1K	2K	3K	4K	1K	2K	3K	4K	1K	2K	3K	4K
1.5	pF	X	H	H																								
1.8	pF	X	X	H																								
2.2~8.2	pF	X	X	H					X	X	X	X																
10	pF	X	H	H	L	C	C	L	X	X	X	X	X	X	X	Z	Z	Z	Z	Z	Z	Z	Z	Z	Z	Z	Z	Z
12	pF	X	H	H	L	C	C	L	X	X	X	X	X	X	X	Z	Z	Z	Z	Z	Z	Z	Z	Z	Z	Z	Z	Z
15	pF	X	H	H	L	C	C	L	X	X	X	X	X	X	X	Z	Z	Z	Z	Z	Z	Z	Z	Z	Z	Z	Z	Z
18	pF	X	H	H	L	C	C	L	X	X	X	X	X	X	X	Z	Z	Z	Z	Z	Z	Z	Z	Z	Z	Z	Z	Z
22	pF	X	H	H	L	C	C	L	X	X	X	L	X	X	X	X	Z	Z	Z	Z	Z	Z	Z	Z	Z	Z	Z	Z
27	pF	X	H	H	L	C	C	L	X	X	X	L	X	X	X	X	Z	Z	Z	Z	Z	Z	Z	Z	Z	Z	Z	Z
33	pF	X	H	C	L	C	C	L	X	X	X	Z	X	X	X	X	Z	Z	Z	Z	Z	Z	Z	Z	Z	Z	Z	Z
39	pF	X	H	C	L	C	C	L	X	X	X	Z	X	X	X	X	Z	Z	Z	Z	Z	Z	Z	Z	Z	Z	Z	Z
47	pF	X	C	C	L	C	C	L	X	X	X		X	X	X	L	Z	Z	Z	Z	Z	Z	Z	Z	Z	Z	Z	Z
56	pF	X	C	X	L	C	X	L	X	X	X		X	X	X	L	Z	Z	Z	Z	Z	Z	Z	Z	Z	Z	Z	Z
68	pF	X	C	X	L	C	X	L	X	X	X		X	X	X	Z	Z	Z	Z	Z	Z	Z	Z	Z	Z	Z	Z	Z
82	pF	X	X	X	L	C	X	L	X	X	X		X	X	X	Z	Z	Z	Z	Z	Z	Z	Z	Z	Z	Z	Z	Z
100	pF	X	X	X		X	X	L	X	X	Z		X	X	X		Z	Z	Z	Z	Z	Z	Z	Z	Z	Z	Z	Z
120	pF	X	X	L		X	X	L	X	X	Z		X	X	X		Z	Z	Z	Z	Z	Z	Z	Z	Z	Z	Z	Z
150	pF	X	X	L		X	L	L	X	Z	Z		X	X	X		Z	Z	Z	Z	Z	Z	Z	Z	Z	Z	Z	Z
180	pF	X	L	L		X	L	L	X	Z	Z		X	X	Z		Z	Z	Z	Z	Z	Z	Z	Z	Z	Z	Z	Z
220	pF	X	L	L		L	L	L	X	Z	Z		X	X	Z		Z	Z	Z		Z	Z	Z	Z	Z	Z	Z	Z
270	pF	X	L	L		L	L		Z	Z	Z		X	Z	Z		Z	Z	Z		Z	Z	Z	G	Z	Z	Z	Z
330	pF	X	L	L		L	L		Z	Z	Z		X	Z	Z		Z	Z	Z		Z	Z	G	G	Z	Z	Z	G
390	pF	X	L	L		L	L		Z	Z	Z		X	Z	Z		Z	Z	Z		Z	Z	G		Z	Z	Z	
470	pF		L	L		L	L		Z	Z	Z		Z	Z	Z		Z	Z	Z		Z	Z	G		Z	Z	Z	
560	pF		L			L	L		Z	Z	Z		Z	Z	Z		Z	Z	Z		Z	Z	G		Z	Z	Z	
680	pF		L			L	L		Z	Z			Z	Z	Z		Z	Z	G		Z	Z	G		Z	Z	Z	
820	pF		L			L	L		Z	Z			Z	Z	G		Z	Z	G		Z	Z	G		Z	G	G	
1000	pF		L			L	Z		Z	Z			Z	Z	G		Z	Z	G		Z	Z	G		Z	G	G	
1200	pF		L			L	Z		Z	Z			Z	Z			Z	Z	G		G	G	G		Z	G	G	
1500	pF					Z	G		Z	Z			Z	Z			Z	G	G		G	G	G		Z	G	G	
1800	pF					G	G		Z	Z			Z	Z			Z	G	G		G	G	G		Z	G	G	
2200	pF					G			Z				Z	Z			Z	G	G		G	G	G		Z	G	G	
2700	pF					G			Z				Z	G			Z	G	G		G	G	G		Z	G	G	
3300	pF					G			Z				Z	G			Z	G			G	G			Z	G	G	
3900	pF					G			Z				G				G	G			G	G			Z	G		
4700	pF												G				G	G			G	G			Z	G		
5600	pF												G				G	G			G	G			G	G		
6800	pF																G	G			G	G			G	G		
8200	pF																G	G			G	G			G	G		
10000	pF																G				G				G	G		
12000	pF																G				G				G			

Remark: Customized size and specification is available upon request. Please contact us for further details



### 5. Size and capacitance range X7R 10V ~ 50V (Low Voltage)

Size		0402				0603				0805				1206				1210			1812		2220		
(L)	mm	1.00±0.05				1.60±0.10				2.00±0.20				3.20±0.20				3.20±0.30			4.50±0.30		5.70±0.40		
(W)	mm	0.50±0.05				0.80±0.10				1.25±0.20				1.60±0.20				2.50±0.20			3.20±0.20		5.00±0.40		
(T)	mm	0.50±0.05				0.80±0.12				1.25±0.20				1.65±0.20				2.50±0.20			3.00±0.20		3.00±0.20		
(t)	mm	0.15~0.35				0.27~0.60				0.30~0.70				0.30~0.70				0.30~0.70			0.35~1.00		0.35~1.00		
Cap.\W.V.		10	16	25	50	10	16	25	50	10	16	25	50	10	16	25	50	16	25	50	25	50	25	50	
100	pF				S				P				H												
120	pF				S				P				H												
150	pF				S				P				H												
180	pF				S				P				H												
220	pF				S				P				H				H								
270	pF				S				P				H				H								
330	pF				S				P				H				H								
390	pF				S				P				H				H								
470	pF				S				P				H				H								
560	pF				S				P				H				H								
680	pF				S				P				H				H								
820	pF				S				P				H				H								
1000	pF				S				P				H				H								
1200	pF				S				P				H				H								
1500	pF				S				P				H				H								
1800	pF				S				P				H				H								
2200	pF				S				P				H				H								
2700	pF				S				P				H				H								
3300	pF				S				P				H				H								
3900	pF				S				P				H				H								
4700	pF				S				P				H				H								
5600	pF				S				P				H				H								
6800	pF				S				P				H				H								
8200	pF				S				P				H				H								
10	nF			S	S				P				H				H								
12	nF			S					P				H				H								
15	nF			S					P				H				H								
18	nF			S					P				H				H								
22	nF			S	S				P				H				H								
27	nF			S					P				H				H								
33	nF			S					P				H				H								
39	nF			S					P				H				H								
47	nF		S	S	S			P	P				H				H								
56	nF		S					P	P				H				H								
68	nF		S					P	P				H				H								
82	nF		S					P	P				H				H								
100	nF	S	S	S	S		P	P	P				H				H						X		
150	nF					P	P	P		X	X	X					X						X		
220	nF	S	S			P	P	P	P	X	X	X					X						X		
330	nF					P	P	P	P	X	X	X				X	X						X		
470	nF					P	P	P	P	X	X	X				X	L						X		
680	nF					P	P			X	X	X		X	X	L							L/Z		
1.0	uF					P	P	P	P	X	X	X	X		X	X	L			L/X			L/Z	Z	
2.2	uF					P				X	X	X	X		L	L	L			Z			Z	Z	
3.3	uF																			G			G	Z	
4.7	uF									X	X	X			L	L	L		Z	G	Z	G		Z	
10	uF									X	*X				L	L	L		Z	Z/G	G	Z	Z/G	Z	G
22	uF														I				G	G		Z/G		G	

Remark: Customized size and specification is available upon request. Please contact us for further details

## Size and capacitance range X7R 100V ~ 630V (Medium Voltage)

Size		0603			0805				1206					1210					1812					
(L)	mm	1.60±0.10			2.00±0.20				3.20±0.20					3.20±0.30					4.50±0.30					
(W)	mm	0.80±0.10			1.25±0.20				1.60±0.20					2.50±0.20					3.20±0.20					
(T)	mm	0.80±0.12			1.25±0.20				1.65±0.25					2.50±0.20					2.50±0.20					
(t)	mm	0.27~0.60			0.30~0.70				0.30~0.70					0.30~0.70					0.35~1.00					
Cap. \ W.V.		100	200	250	100	200	250	500	630	100	200	250	500	630	100	200	250	500	630	100	200	250	500	630
100	pF	P	P	P	H	H	H	H	H	H	H													
150	pF	P	P	P	H	H	H	H	H	H	H													
220	pF	P	P	P	H	H	H	H	H	H	H	X	X	C	C	C	X	X						
330	pF	P	P	P	H	H	H	H	H	H	H	X	X	C	C	C	X	X	X	X	X	X	X	
470	pF	P	P	P	H	H	H	H	H	H	H	X	X	C	C	C	X	X	X	X	X	X	X	
560	pF	P	P	P	H	H	H	H	H	H	H	X	X	C	C	C	X	X	X	X	X	X	X	
680	pF	P	P	P	H	H	H	H	H	H	H	X	X	C	C	C	X	X	X	X	X	X	X	
1000	pF	P	P	P	H	H	H	H	H	H	H	X	X	C	C	C	X	X	X	X	X	X	X	
1500	pF	P	P	P	H	H	H	H	H	H	H	X	X	C	C	C	X	X	X	X	X	X	X	
2200	pF	P	P	P	H	H	H	H	H	H	H	X	X	C	C	C	X	X	X	X	X	X	X	
3300	pF	P	P	P	H	H	H	H	H	H	H	X	X	C	C	C	X	X	X	X	X	X	X	
4700	pF	P	P	P	H	H	H	X	H	H	H	X	X	C	C	C	X	X	X	X	X	X	X	
5600	pF	P	P	P	H	H	H	X	H	H	H	X	X	C	C	C	X	X	X	X	X	X	X	
6800	pF	P	P	P	H	H	H	X	H	H	H	X	X	C	C	C	X	X	X	X	X	X	X	
10	nF	P	P	P	H	H	H	X	H	H	H	X	X	C	C	C	X	X	X	X	X	X	X	
15	nF	P	P	P	H	H	H	X	H	X	X	X	X	C	C	C	X	X	X	X	X	X	X	
22	nF	P			H	H	H	X	H	X	X	L	L	C	C	C	X	X	X	X	X	X	X	
33	nF	P			X	X	X		X	L	L	L	L	C	C	C	L	L	X	X	X	X	X	
47	nF	P			X	X	X		X	L	L	L	L	C	X	X	L	L	X	X	X	X	X	
56	nF	P			X	X	X		X	L	L	L	L	C	X	X	L	L	X	X	X	L	L	
68	nF	P			X	X	X		X	L	L			C	L	L	L/Z	L/Z	X	X	X	L	L	
100	nF	P			X	X			X	L	L			C	L	L	G	G	L	X	X	L	L	
150	nF				X				L	L	L			X	G	G	G	G	L	L	L	G	G	
220	nF				X				L	L	L			X	G	G			L	L	L	G	G	
330	nF								L					L	G	G			L	L	Z	G	G	
470	nF								L					L	G	G			L	L	Z	G		
680	nF								L					Z	G	G			Z	G	G			
1.0	uF								L					Z					Z	G	G			
1.5	uF								L					G					Z					
2.2	uF								L					G					G					
3.3	uF																		G					
4.7	uF																		G					
10	uF																		G					

Remark: Customized size and specification is available upon request. Please contact us for further details

## Size and capacitance range X7R 100V ~ 630V (Medium Voltage)

Size		1825					2220					2225				
(L)	mm	4.50±0.30					5.70±0.40					5.70±0.40				
(W)	mm	6.30±0.40					5.00±0.40					6.30±0.40				
(T)	mm	2.50±0.30					3.00±0.20					3.00±0.20				
(t)	mm	0.35~1.00					0.35~1.00					0.35~1.00				
Cap. \\ W.V		100	200	250	500	630	100	200	250	500	630	100	200	250	500	630
470	pF															
680	pF															
1000	pF	Z	Z	Z	Z	Z	Z	Z	Z	Z	Z	Z	Z	Z	Z	Z
1500	pF	Z	Z	Z	Z	Z	Z	Z	Z	Z	Z	Z	Z	Z	Z	Z
2200	pF	Z	Z	Z	Z	Z	Z	Z	Z	Z	Z	Z	Z	Z	Z	Z
3300	pF	Z	Z	Z	Z	Z	Z	Z	Z	Z	Z	Z	Z	Z	Z	Z
4700	pF	Z	Z	Z	Z	Z	Z	Z	Z	Z	Z	Z	Z	Z	Z	Z
6800	nF	Z	Z	Z	Z	Z	Z	Z	Z	Z	Z	Z	Z	Z	Z	Z
10	nF	Z	Z	Z	Z	Z	Z	Z	Z	Z	Z	Z	Z	Z	Z	Z
15	nF	Z	Z	Z	Z	Z	Z	Z	Z	Z	Z	Z	Z	Z	Z	Z
22	nF	Z	Z	Z	Z	Z	Z	Z	Z	Z	Z	Z	Z	Z	Z	Z
33	nF	Z	Z	Z	Z	Z	Z	Z	Z	Z	Z	Z	Z	Z	Z	Z
47	nF	Z	Z	Z	Z	Z	Z	Z	Z	Z	Z	Z	Z	Z	Z	Z
68	nF	Z	Z	Z	Z	Z	Z	Z	Z	Z	Z	Z	Z	Z	Z	Z
100	nF	Z	Z	Z	Z	Z	Z	Z	Z	Z	Z	Z	Z	Z	Z	Z
150	nF	Z	Z	Z	Z	Z	Z	Z	Z	Z	Z	Z	Z	Z	Z	Z
220	nF	Z	Z	Z	Z	Z	Z	Z	Z	Z	Z	Z	Z	Z	Z	Z
330	nF	Z	Z	Z	Z	Z	Z	Z	Z	Z	Z	Z	Z	Z	Z	Z
470	nF	Z	Z	Z	Z	Z	Z	Z	Z	Z	Z	Z	Z	Z	G	G
680	nF	Z	Z	Z	Z	Z	Z	Z	Z	Z	Z	Z	Z	Z	G	G
1.0	uF	Z	Z	Z			Z	Z	Z			Z	Z	Z	G	G
2.2	uF	Z	G	G			Z	G	G			Z	G	G		
3.3	uF	Z					Z					Z				
4.7	uF	G					G					G				
6.8	uF						U					G				
10	uF						U					G				

Remark: Customized size and specification is available upon request. Please contact us for further details

**Size and capacitance range X7R 1000V ~ 4000V (High Voltage)**

Size		0805	1206		1210		1808			1812				1825				2220				2225			
(L)	mm	2.10±0.20	3.30±0.30		3.30±0.30		4.60±0.40			4.60±0.40				4.50±0.30				5.70±0.40				5.70±0.40			
(W)	mm	1.25±0.20	1.60±0.20		2.50±0.20		2.00±0.25			3.20±0.40				6.30±0.40				5.00±0.40				6.30±0.40			
(T)	mm	1.25±0.20	1.65±0.20		2.50±0.20		2.00±0.20			3.00±0.20				2.50±0.30				3.00±0.20				3.00±0.20			
(t)	mm	0.30~0.70	0.40~0.80		0.40~1.10		0.40~1.10			0.40~1.10				0.40~1.10				0.40~1.10				0.40~1.10			
Cap.\\W.V.		1K	1K	2K	1K	2K	1K	2K	3K	1K	2K	3K	4K	1K	2K	3K	4K	1K	2K	3K	4K	1K	2K	3K	4K
100	pF	H	X	X																					
120	pF	H	X	X																					
150	pF	H	X	X			X	X	X																
180	pF	H	X	X			X	X	X																
220	pF	H	X	X			X	X	X																
270	pF	H	X	X	X	L	X	X	X	X	X	L	Z				Z					Z			Z
330	pF	H	X	X	X	L	X	X	Z	X	X	L	Z				Z					Z			Z
390	pF	H	X	X	X	L	X	X	Z	X	X	L	Z				Z					Z			Z
470	pF	H	X	X	X	L	X	X	Z	X	X	L	Z				Z					Z			Z
560	pF	H	X	X	X	L	X	X	Z	X	X	L	Z				Z					Z			Z
680	pF	H	X	X	X	L	X	X	Z	X	X	Z	Z				Z					Z			Z
820	pF	H	X	X	X	L	X	X	Z	X	X	Z	Z				Z					Z			Z
1000	pF	H	X	X/L	X	L	X	X	Z	X	X	Z	Z	Z	Z	Z	Z	Z	Z	Z	Z	Z	Z	Z	Z
1200	pF	H	X	L	X	Z	X	Z	Z	X	X	Z	G	Z	Z	Z	G	Z	Z	Z	G	Z	Z	Z	G
1500	pF	X	X	L	X	Z	X	Z	Z	X	X	Z	G	Z	Z	Z	G	Z	Z	Z	G	Z	Z	Z	G
1800	pF	X	X	L	X	Z	X	Z	Z	X	L	G	G	Z	Z	Z	G	Z	Z	Z	G	Z	Z	Z	G
2200	pF	X	X	L	X	Z	X	Z	Z	X	L	G		Z	Z	Z		Z	Z	Z		Z	Z	Z	
2700	pF	X	X	L	X	G	X	Z		X	L	G		Z	Z	Z		Z	Z	Z		Z	Z	Z	
3300	pF	X	X	L	X	G	X	Z		X	Z	G		Z	Z	Z		Z	Z	Z		Z	Z	Z	
3900	pF	X	X		L	G	X	Z		X	Z	G		Z	Z	Z		Z	Z	Z		Z	Z	Z	
4700	pF	X	X		L	G	X	Z		X	Z	G		Z	Z	Z		Z	Z	Z		Z	Z	Z	
5600	pF	X	X		L	G	Z	Z		X	G			Z	Z	G		Z	Z	Z		Z	Z	G	
6800	pF	X	X		L	G	Z	Z		X	G			Z	Z	G		Z	Z	G		Z	Z	G	
8200	pF	X	X		L	G	Z			X	G			Z	Z	G		Z	G	G		Z	Z	G	
10	nF		X		L		Z			X/L	G			Z	Z	G		Z	G	G		Z	Z	G	
12	nF		L		L		Z			Z				Z	G	U		Z	G	U		Z	G	G	
15	nF		L		L		Z			Z				Z	G	U		Z	G	U		Z	G	G	
18	nF		L		L		Z			G				Z	G	U		Z	U	U		Z	G	U	
22	nF		L		L		Z			G				Z	G			Z	U			Z	G		
27	nF				L		Z			G				Z	U			Z	U			Z	G		
33	nF				L		Z			G				Z	U			Z	U			Z	G		
39	nF					Z		Z		G				Z	U			Z	U			Z	U		
47	nF					G		Z		G				Z	U			Z	U			Z	U		
56	nF					G		Z		G				Z	U			Z	U			Z	U		
68	nF					G		Z		G				Z				G				Z			
82	nF									G				G				G				Z			
100	nF									G				G				G				G			
120	nF													U				G				U			
150	nF													U				U				U			
180	nF													U				U				U			
220	nF													U				U				U			
330	nF													U				U				U			
390	nF													U				U				U			

### Size and capacitance range X5R 6.3V ~ 50V

Size		0402					0603					0805					1206						
(L)	mm	1.00±0.05					1.60±0.10					2.00±0.20					3.20±0.20						
(W)	mm	0.50±0.05					0.80±0.10					1.25±0.20					1.60±0.20						
(T)	mm	0.50±0.05					0.80±0.12					1.25±0.20					1.65±0.20						
(t)	mm	0.15~0.35					0.27~0.60					0.30~0.70					0.30~0.70						
Cap./ W.V.		6.3	10	16	25	50	4	6.3	10	16	25	50	4	6.3	10	16	25	50	6.3	10	16	25	50
100	nF			S	S	S																	
220	nF	S	S	S	S						P												
330	nF	S									P												
470	nF	S	S	S	S					P	P	P											
680	nF	S							P	P	P												
1.0	uF	S	S	S	S				P	P	P	P											L
2.2	uF	S	S	S	S			P	P	P	P	P		X	X	X	X	X					L
3.3	uF	S																				L	L
4.7	uF	S	S	*S				P	P	P	P			X	X	X	X	X			L	L	L
10	uF	*S	*S					*P	*P	*P	*P			X	X	X	X	X		L	L	L	L
22	uF						*P	*P	*P					*X	*X	*X	*X		*L	*L	*L	*L	
47	uF												*X	*X	*X				*L	*L	*L	*L	
100	uF												*X						*L	*L			

Size		1210					1812					2220				
(L)	mm	3.20±0.30					4.50±0.30					5.70±0.40				
(W)	mm	2.50±0.20					3.20±0.20					5.00±0.40				
(T)	mm	2.50±0.30					3.00±0.20					3.00±0.20				
(t)	mm	0.30~0.70					0.35~1.00					0.35~1.00				
Cap./ W.V.		4	6.3	10	16	25	50	4	6.3	10	16	25	10	16	25	50
1.0	uF															
2.2	uF						G									
3.3	uF															
4.7	uF						G									
10	uF			*C/Z	*C/Z	*C/G	G					G				G
22	uF			*C/G	*C/G	G					*G	*G			*G	
47	uF		*G	*G	*G				*G	*U				*G		
100	uF		*G	*G					*U	*U			*G			
220	uF	*G	*G													
330	uF	*G	*G													
470	uF							*U								

\*\_Standard is 20% tolerance. 10% maybe available upon request. Please make contact with sales

## Thickness Code & Standard Packing Q'ty per reel

Thickness Code	Chip Size	Chip Thickness	Max Tape Thickness	Q'ty of carboard tape in		Q'ty of Embosses tape in	
				7" reel	13" reel	7" reel	13" reel
S	0402	0.50±0.05 mm	0.60 mm	10,000	50,000	--	--
P	0603	0.80±0.10 mm	0.95 mm	4,000	15,000	--	--
A	0805	0.60±0.10 mm	0.75 mm	4,000	15,000	--	--
H		0.85±0.10 mm	0.95 mm	4,000	15,000	--	--
X		1.25±0.10 mm	1.80 mm	--	--	3,000	10,000
H	1206	0.85±0.10 mm	0.90 mm	4,000	15,000	--	--
C		0.95±0.10 mm	1.80 mm			3,000	10,000
X		1.25±0.10 mm	1.80 mm	--	--	3,000	10,000
L		1.65±0.20 mm	1.80 mm	--	--	2,000	--
C	1210	0.95±0.10 mm	1.80 mm			3,000	10,000
X		1.25±0.10 mm	1.80 mm	--	--	3,000	--
L		1.65±0.20 mm	1.80 mm	--	--	2,000	--
Z		2.00±0.20 mm	2.20 mm	--	--	2,000	--
G		2.50±0.20 mm	2.75 mm	--	--	1,000	--
X	1808	1.25±0.10 mm	1.80 mm	--	--	2,000	--
F		1.40±0.20 mm	1.80 mm	--	--	2,000	--
L		1.65±0.20 mm	1.80 mm	--	--	2,000	--
Z		2.00±0.20 mm	2.20 mm	--	--	1,000	--
X	1812	1.25±0.20 mm	1.80 mm	--	--	1,000	--
L		1.65±0.20 mm	1.80 mm			1,000	
Z		2.00±0.20 mm	2.20 mm	--	--	1,000	--
G		2.50±0.20 mm	2.75 mm	--	--	500	--
U		2.80±0.30 mm	3.00 mm	--	--	500	--
Z	1825	2.00±0.20 mm	2.20 mm	--	--	1,000	--
G		2.50±0.20 mm	2.75 mm	--	--	500	--
U		2.80±0.30 mm	3.00 mm	--	--	500	
Z	2220	2.00±0.20 mm	2.20 mm	--	--	500	--
G		2.50±0.20 mm	2.75 mm	--	--	500	--
U		2.80±0.30 mm	3.00 mm	--	--	500	--
Z	2225	2.00±0.20 mm	2.20 mm	--	--	1,000	--
G		2.50±0.20 mm	2.75 mm	--	--	500	--

## 7. SPECIFICATIONS AND TEST METHODS

No	Item	Test Method	Specification																																						
1	Capacitance	<p>The capacitance shall be measured at 25°C at the frequency and voltage shown below:</p> <table border="1" style="width: 100%; border-collapse: collapse;"> <tr> <td style="text-align: center;">Type</td> <td style="text-align: center;">NPO (≤1nF)</td> <td style="text-align: center;">NPO&gt;1nF, Y5V, X7R/X5R</td> <td style="text-align: center;">C&gt;10uF</td> </tr> <tr> <td style="text-align: center;">Item</td> <td></td> <td></td> <td></td> </tr> <tr> <td style="text-align: center;">Freq.</td> <td style="text-align: center;">1±0.1Mhz</td> <td style="text-align: center;">1±0.1KHz</td> <td style="text-align: center;">120H</td> </tr> <tr> <td style="text-align: center;">Voltage</td> <td style="text-align: center;">1±0.2Vrms</td> <td style="text-align: center;">1±0.2Vrms</td> <td style="text-align: center;">0.5±0.2 Vrms</td> </tr> </table>	Type	NPO (≤1nF)	NPO>1nF, Y5V, X7R/X5R	C>10uF	Item				Freq.	1±0.1Mhz	1±0.1KHz	120H	Voltage	1±0.2Vrms	1±0.2Vrms	0.5±0.2 Vrms	<p>Within the specified tolerance</p> <p style="color: red;">Remark: For ClassII(X7R/X5R,Y5V), Before initial test, please perform De-aging process as below: Heat up to 150°C for 1Hr and then set form 48±4 Hrs at room temp.</p>																						
Type	NPO (≤1nF)	NPO>1nF, Y5V, X7R/X5R	C>10uF																																						
Item																																									
Freq.	1±0.1Mhz	1±0.1KHz	120H																																						
Voltage	1±0.2Vrms	1±0.2Vrms	0.5±0.2 Vrms																																						
2	Q value / Dissipation Factor	<p>D.F. shall be measured at 25°C at the frequency and voltage shown above.</p> <p style="text-align: center;">EXCEPTION OF D.F.</p> <p><b>X7R/X5R</b></p> <table border="1" style="width: 100%; border-collapse: collapse;"> <thead> <tr> <th style="text-align: center;">r</th> <th style="text-align: center;">D.F.</th> <th style="text-align: center;">Exc ption of D.F.</th> </tr> </thead> <tbody> <tr> <td rowspan="3" style="text-align: center;">≥ 50V</td> <td style="text-align: center;">≤3.5%</td> <td style="text-align: center;">0603≥47nF, 0805≥0.18uF, 1206≥0.47uF, 1210≥1.0uF</td> </tr> <tr> <td rowspan="2" style="text-align: center;">25V</td> <td style="text-align: center;">≤5%</td> <td style="text-align: center;">0805≥1.0uF, 1210≥10uF</td> </tr> <tr> <td style="text-align: center;">≤7%</td> <td style="text-align: center;">0603≥0.33uF, 1206≥4.7uF</td> </tr> <tr> <td rowspan="3" style="text-align: center;">16V</td> <td style="text-align: center;">≤10%</td> <td style="text-align: center;">0603≥0.47uF,0805≥2.2uF 1206≥6.8uF,0402≥0.1uF</td> </tr> <tr> <td rowspan="2" style="text-align: center;">≤5%</td> <td style="text-align: center;">0402≥33nF, 0603≥0.15uF 0805≥0.68uF, 1206≥2.2uF, 1210≥4.7uF,</td> </tr> <tr> <td style="text-align: center;">≤10%</td> <td style="text-align: center;">0603≥0.68uF, 0805≥2.2uF, 1206≥4.7uF, 1210≥22uF,</td> </tr> <tr> <td style="text-align: center;">10V</td> <td style="text-align: center;">≤10%</td> <td style="text-align: center;">0402&amp;0603≥0.33uF,0805≥2.2uF, 1206≥2.2uF, 1210≥22uF</td> </tr> </tbody> </table> <p><b>Y5V</b></p> <table border="1" style="width: 100%; border-collapse: collapse;"> <thead> <tr> <th style="text-align: center;">Vr</th> <th style="text-align: center;">D.F.</th> <th style="text-align: center;">Exception of D.F.</th> </tr> </thead> <tbody> <tr> <td style="text-align: center;">≥50V</td> <td style="text-align: center;">≤7%</td> <td style="text-align: center;">0603≥0.1uF, 0805≥0.47uF, 1206≥4.7uF</td> </tr> <tr> <td rowspan="2" style="text-align: center;">25V</td> <td style="text-align: center;">≤9%</td> <td style="text-align: center;">0402≥47nF, 0805≥0.47uF</td> </tr> <tr> <td style="text-align: center;">≤12.5%</td> <td style="text-align: center;">1210/10uF</td> </tr> <tr> <td style="text-align: center;">16V</td> <td style="text-align: center;">≤9%</td> <td style="text-align: center;">0402≥0.068uF, 0603≥0.68uF</td> </tr> <tr> <td style="text-align: center;">16V (≥1uF)</td> <td style="text-align: center;">≤12.5%</td> <td style="text-align: center;">0603≥2.2uF,0805≥3.3uF, 1206≥10uF,1210≥22uF, 1812≥47uF,</td> </tr> </tbody> </table>	r	D.F.	Exc ption of D.F.	≥ 50V	≤3.5%	0603≥47nF, 0805≥0.18uF, 1206≥0.47uF, 1210≥1.0uF	25V	≤5%	0805≥1.0uF, 1210≥10uF	≤7%	0603≥0.33uF, 1206≥4.7uF	16V	≤10%	0603≥0.47uF,0805≥2.2uF 1206≥6.8uF,0402≥0.1uF	≤5%	0402≥33nF, 0603≥0.15uF 0805≥0.68uF, 1206≥2.2uF, 1210≥4.7uF,	≤10%	0603≥0.68uF, 0805≥2.2uF, 1206≥4.7uF, 1210≥22uF,	10V	≤10%	0402&0603≥0.33uF,0805≥2.2uF, 1206≥2.2uF, 1210≥22uF	Vr	D.F.	Exception of D.F.	≥50V	≤7%	0603≥0.1uF, 0805≥0.47uF, 1206≥4.7uF	25V	≤9%	0402≥47nF, 0805≥0.47uF	≤12.5%	1210/10uF	16V	≤9%	0402≥0.068uF, 0603≥0.68uF	16V (≥1uF)	≤12.5%	0603≥2.2uF,0805≥3.3uF, 1206≥10uF,1210≥22uF, 1812≥47uF,	<p>NPO: C &lt; 30pF : Q value ≥ 400+20C C ≥ 30pF : Q value ≥ 1000</p> <p>X7R/ X5R : Vr=50V~6KV, DF≤2.5% Vr=25V, DF≤3.5% Vr=16V, DF≤3.5% Vr=10V, DF≤5.0% Vr=6.3V, DF≤10.0%</p> <p>Y5V: Vr=≥50V, DF≤5.0% Vr =25V, DF≤7.0% Vr=16V(C &lt; 1.0uF), DF≤7.0% Vr=16V(C ≥ 1.0uF), DF≤9.0% Vr=10V, DF≤12.5% Vr=6.3V, DF≤20%</p> <p style="color: red;">( see EXCEPTION at left side)</p>
r	D.F.	Exc ption of D.F.																																							
≥ 50V	≤3.5%	0603≥47nF, 0805≥0.18uF, 1206≥0.47uF, 1210≥1.0uF																																							
	25V	≤5%	0805≥1.0uF, 1210≥10uF																																						
		≤7%	0603≥0.33uF, 1206≥4.7uF																																						
16V	≤10%	0603≥0.47uF,0805≥2.2uF 1206≥6.8uF,0402≥0.1uF																																							
	≤5%	0402≥33nF, 0603≥0.15uF 0805≥0.68uF, 1206≥2.2uF, 1210≥4.7uF,																																							
		≤10%	0603≥0.68uF, 0805≥2.2uF, 1206≥4.7uF, 1210≥22uF,																																						
10V	≤10%	0402&0603≥0.33uF,0805≥2.2uF, 1206≥2.2uF, 1210≥22uF																																							
Vr	D.F.	Exception of D.F.																																							
≥50V	≤7%	0603≥0.1uF, 0805≥0.47uF, 1206≥4.7uF																																							
25V	≤9%	0402≥47nF, 0805≥0.47uF																																							
	≤12.5%	1210/10uF																																							
16V	≤9%	0402≥0.068uF, 0603≥0.68uF																																							
16V (≥1uF)	≤12.5%	0603≥2.2uF,0805≥3.3uF, 1206≥10uF,1210≥22uF, 1812≥47uF,																																							
3	Insulation Resistance	<p>Rated voltage ≤100V : Apply RV for 120 sec.</p> <p>Rated voltage 200-630V : Apply RV for 60 sec.</p> <p>Rated voltage 1KV-6KV : Apply 500V for 60 sec.</p>	<p>NPO : ≥ 10GΩ or 500Ω-F(whichever is smaller)</p> <p>X7R/X5R, Y5V : ≥ 10GΩ or 100Ω-F(whichever is smaller)</p>																																						
4	Dielectric Strength	<p>Test voltage(Vt): (Duration 1~5 seconds.)</p> <p>Vt= Vr X250% (Vr≤100V) Charge current: ≤ 50mA</p> <p>Vt= Vr X200% For product Vr=200V/250V</p> <p>Vt= Vr X150% For product Vr=500V~999V</p> <p>Vt= Vr X120% For product Vr=1KV~3KV</p> <p>Vt= Vr X110% For Vr≤5KV, Vt= Vr X100% For Vr &gt; 5KV</p>	<p>No evidence of damage or flash over during test.</p>																																						
5	Solderability	<p>*Solder temperature : 235±5°C</p> <p>*Dipping time : 2±0.5 sec.</p>	<p>95% min. coverage of all metalized area</p>																																						

## SPECIFICATIONS AND TEST METHODS

No	Item	Test Method	Specification			
6	Vibration Resistance	*Vibration Frequency: 10 – 55 Hz.min.  *Total amplitude: 1.5mm  *Test Time: 6 hrs ( Two hrs each in three mutually perpendicular direction )	No remarkable damage Cap. Change and Q/D.F.: To meet initial spec.			
7	Resistance to Soldering Heat	Preheat the capacitor at 120~150°C for 1min. Have the capacitor dip into the solder bath at 270±5°C for 10±1 sec. Set it at room temperature for 48±4hrs, then measure.  ■ Initial measurement for X7R/X5R and Y5V. Perform a heat treatment at 150±5°C for 1 hr and then set for 48±4 hrs at room temperature then measure.	Dielect ic	NPO	X7R/X5R	Y5V
			Appearance	No defect		
			Capacitanc e chang	<±2.5% or±0.25 pf	±7.5%	±20%
			DF( or Q)	C ≥ 30pf : Q ≥ 1000 C < 30pf : Q ≥ 4 0+20C	Same s no.2	Same as no.2
			I.R	More than 10GΩ or 500ΩF (Whichever is Smaller)		
			Diele tric Strength	No failure		
8	Adhesiv Strength of Termination	*Pressurizing force: 5N(≤0603) and 10n(>0603)  *Test time: 10 ± 1 sec.	No remarkable damage or removal of t e termination.			
9	High temperature Load	*Test Temp. : NPO, X7R : 125±3°C X5R, Y5V : 85±3°C  *Test Voltage: (1) V < 500V : 2 X R.V. (2) 500 ≤ V < 1000V : 1.5 X R.V. (3) V = 1000V ~ 3000V : 1.2 X R.V. (4) V > 3000V : 100% of R.V.  *Test Time: 1000 hrs  *Measurement to be made after keeping at room temp. for 48± hr.	Dielectric	NPO	X7R/X R	Y5V
			Appearance	No defe t		
			Capacitanc change	<±3% or±0.3 pF whichever is larger	≥10V: ±12.5% 6.3V : ±25%	±30%
			DF( or Q)	SAME AS NO. 2		
			I.R.	≥ 10V, ≥ 1GΩ or 50Ω-F (whichever is smaller) 6.3V: ≥ 10Ω-F		
			Dielectric strength	No failure		



**SPECIFICATIONS AND TEST METHODS**

No	Item	Test Method	Specification																											
10	Temperature Coefficient	<p>(a) NPO The temperature coefficient is determined using the capacitance measured in step 3 as a reference. When cycling the temperature sequentially from step 1 through 5. The capacitance shall be within the specified tolerance for the temperature coefficient.</p> <table border="1"> <thead> <tr> <th>Step</th> <th>Temperature(°C)</th> </tr> </thead> <tbody> <tr> <td>1</td> <td>+25±2°C</td> </tr> <tr> <td>2</td> <td>-55±3°C</td> </tr> <tr> <td>3</td> <td>+25±2°C</td> </tr> <tr> <td>4</td> <td>+125±3°C(for NPO/X7R +85 ± 3°C(for X5R/Y5V))</td> </tr> <tr> <td>5</td> <td>+25±2°C</td> </tr> </tbody> </table> <p>(b) X7R/X5R,Y5V The ranges of capacitance change compared with the 25±2°C value over the temperature range shall be within the specified ranges</p>	Step	Temperature(°C)	1	+25±2°C	2	-55±3°C	3	+25±2°C	4	+125±3°C(for NPO/X7R +85 ± 3°C(for X5R/Y5V))	5	+25±2°C	<table border="1"> <thead> <tr> <th>Dielectric</th> <th>Temperature Range</th> <th>Capacitance Change</th> </tr> </thead> <tbody> <tr> <td>NPO</td> <td>-55°C to +125°C</td> <td>0±30ppm/°C</td> </tr> <tr> <td>X7R</td> <td>-55°C to +125°C</td> <td>Within ±15%</td> </tr> <tr> <td>X5R</td> <td>-55°C to +85°C</td> <td>Within ±15%</td> </tr> <tr> <td>Y5V</td> <td>-25°C to +85°C</td> <td>Within +30%~-80%</td> </tr> </tbody> </table>	Dielectric	Temperature Range	Capacitance Change	NPO	-55°C to +125°C	0±30ppm/°C	X7R	-55°C to +125°C	Within ±15%	X5R	-55°C to +85°C	Within ±15%	Y5V	-25°C to +85°C	Within +30%~-80%
			Step	Temperature(°C)																										
			1	+25±2°C																										
			2	-55±3°C																										
			3	+25±2°C																										
4	+125±3°C(for NPO/X7R +85 ± 3°C(for X5R/Y5V))																													
5	+25±2°C																													
Dielectric	Temperature Range	Capacitance Change																												
NPO	-55°C to +125°C	0±30ppm/°C																												
X7R	-55°C to +125°C	Within ±15%																												
X5R	-55°C to +85°C	Within ±15%																												
Y5V	-25°C to +85°C	Within +30%~-80%																												
11	Resistance to board bending	<p>Mount the capacitor to the testing printed wiring board. Then apply force in the direction shown in Fig.3. The bending stroke shall be more than 1mm, Pressurizing is carried out at the rate of 1mm/s. After reaching the specified bending, keeping it for 5±1 seconds then measure the capacitance value.</p> <p>Cap. Change : NPO: ±5% or ±0.5 pF whichever is larger X7R, X5R: ±12.5% Y5V: ±30%</p> <p>( This capacitance change means the change of capacitance under specified flexure of substrate from the capacitance measured before the test )</p>	<p>No cracking or marking defects shall occur Fig.3</p> <p>Unit: mm</p>																											
			12	Chip Break Strength	<p>Place the capacitor on an iron plate, And then gradually apply a load on the center of the chip until it breaks.</p> <p>Tip of push-pull gauge is shown in Fig.4</p>	<p>To load 2 kgf at least.</p> <p>Fig.4</p>																								

**SPECIFICATIONS AND TEST METHODS**

No	Item	Test Method	Specification																												
13	Temperature cycle	<p>Mount the capacitor on test board, then cycling the temperature sequentially from step 1 to step 5, and perform 25 cycles.</p> <table border="1"> <thead> <tr> <th rowspan="2">Step.</th> <th>NPO</th> <th>X7R</th> <th>X5R/Y5V</th> </tr> <tr> <th colspan="2">Temperature (°C) /time(min)</th> <th>Temperature(°C) /time(min)</th> </tr> </thead> <tbody> <tr> <td>1</td> <td colspan="2">+25±2°C / 3±1</td> <td>+25±2°C / 3±1</td> </tr> <tr> <td>2</td> <td colspan="2">-55±2°C / 30±3</td> <td>-30±2°C / 30±3</td> </tr> <tr> <td>3</td> <td colspan="2">+25±2°C / 3±1</td> <td>+25±2°C / 3±1</td> </tr> <tr> <td>4</td> <td colspan="2">+125±3°C / 30±3</td> <td>+85±3°C / 30±3</td> </tr> <tr> <td>5</td> <td colspan="2">+25±2°C / 3±1</td> <td>+25±2°C / 3±1</td> </tr> </tbody> </table> <p>Remove and let sit for 24±2hours(NPO) or 48±4hours(X7R/X5R,Y5V) at room temperature, then measure</p>	Step.	NPO	X7R	X5R/Y5V	Temperature (°C) /time(min)		Temperature(°C) /time(min)	1	+25±2°C / 3±1		+25±2°C / 3±1	2	-55±2°C / 30±3		-30±2°C / 30±3	3	+25±2°C / 3±1		+25±2°C / 3±1	4	+125±3°C / 30±3		+85±3°C / 30±3	5	+25±2°C / 3±1		+25±2°C / 3±1	<p>*No remarkable damage.</p> <p>*Cap. Change : NPO: ±2.5% or ±0.5 pF whichever is larger</p> <p>X7R, X5R: ±7.5%</p> <p>Y5V: ±20%</p> <p>*Q/D.F..I.R &amp; dielectric strength : To meet initial requirement.</p>	
Step.	NPO	X7R		X5R/Y5V																											
	Temperature (°C) /time(min)		Temperature(°C) /time(min)																												
1	+25±2°C / 3±1		+25±2°C / 3±1																												
2	-55±2°C / 30±3		-30±2°C / 30±3																												
3	+25±2°C / 3±1		+25±2°C / 3±1																												
4	+125±3°C / 30±3		+85±3°C / 30±3																												
5	+25±2°C / 3±1		+25±2°C / 3±1																												
14	Humidity ( Damp Heat) Steady State	<p>*Test temp.: 40±2°C</p> <p>*Humidity: 90~95% RH</p> <p>*Test time: 500 hrs</p> <p>*Measurement to be made after keeping at room temperature for 48±4 hrs.</p> <p><b>EXCEPTION OF D.F.</b></p> <p>X7R/X5R:</p> <table border="1"> <thead> <tr> <th>Vr</th> <th>D.F</th> <th>Exception of D.F.</th> </tr> </thead> <tbody> <tr> <td>≥ 50V</td> <td>≤ 6%</td> <td>0603 ≥ 47nF, 0805 ≥ 0.18uF, 1206 ≥ 0.47uF, 1210 ≥ 1.0uF</td> </tr> <tr> <td rowspan="2">25V</td> <td>≤ 10%</td> <td>0805 ≥ 1.0uF, C ≥ 4.7Uf</td> </tr> <tr> <td>≤ 14%</td> <td>0603 ≥ 0.33uF</td> </tr> <tr> <td>16V</td> <td>≤ 10%</td> <td>0402 ≥ 33nF, 0603 ≥ 0.15uF, 0805 ≥ 0.68uF, C ≥ 2.2uF</td> </tr> <tr> <td>10V</td> <td>≤ 15%</td> <td>0402 ≥ 56nF, 0603 ≥ 0.33uF, C ≥ 2.2uF</td> </tr> </tbody> </table> <p>Y5V:</p> <table border="1"> <thead> <tr> <th>Vr</th> <th>D.F</th> <th>Exception of D.F.</th> </tr> </thead> <tbody> <tr> <td rowspan="2">25V</td> <td>≤ 10%</td> <td>0603 ≥ 0.1uF, 0805 ≥ 0.33uF, 1206 ≥ 1.0 uF</td> </tr> <tr> <td>≤ 12.5%</td> <td>0402 ≥ 0.047uF</td> </tr> <tr> <td>16V</td> <td>≤ 12.5%</td> <td>0402 ≥ 0.047uF</td> </tr> </tbody> </table>	Vr	D.F	Exception of D.F.	≥ 50V	≤ 6%	0603 ≥ 47nF, 0805 ≥ 0.18uF, 1206 ≥ 0.47uF, 1210 ≥ 1.0uF	25V	≤ 10%	0805 ≥ 1.0uF, C ≥ 4.7Uf	≤ 14%	0603 ≥ 0.33uF	16V	≤ 10%	0402 ≥ 33nF, 0603 ≥ 0.15uF, 0805 ≥ 0.68uF, C ≥ 2.2uF	10V	≤ 15%	0402 ≥ 56nF, 0603 ≥ 0.33uF, C ≥ 2.2uF	Vr	D.F	Exception of D.F.	25V	≤ 10%	0603 ≥ 0.1uF, 0805 ≥ 0.33uF, 1206 ≥ 1.0 uF	≤ 12.5%	0402 ≥ 0.047uF	16V	≤ 12.5%	0402 ≥ 0.047uF	<p>*No remarkable damage</p> <p>*Cap. Change : NPO: ±5% or ±0.5 pF whichever is larger X7R/X5R: ≥ 10V: ±12.5%, 6.3V : ±25% Y5V: ±30%</p> <p>*Q value/D.F. NPO : C ≥ 30pf : Q ≥ 350 10pf ≤ Cap &lt; 30pf, Q ≥ 275+2.5C Cap &lt; 10pf, Q ≥ 200+10C X7R, X5R : Vr ≥ 50V, D.F. ≤ 3% Vr=16/25V, D.F. ≤ 5% Vr=10V, D.F. ≤ 7.5% Y5V : Vr ≥ 25/50V, D.F. ≤ 7.5% Vr=16V(C &lt; 1.0uF), DF ≤ 10% Vr=16V(C ≥ 1.0uF), DF ≤ 12.5% Vr=10V, D.F. ≤ 15% Vr=6.3V, D.F. ≤ 30% <b>(See EXCEPTION at left side)</b></p> <p>≥ 10V, ≥ 1GΩ or 50Ω-F (whichever is smaller) 6.3V: ≥ 10Ω-F</p>
Vr	D.F	Exception of D.F.																													
≥ 50V	≤ 6%	0603 ≥ 47nF, 0805 ≥ 0.18uF, 1206 ≥ 0.47uF, 1210 ≥ 1.0uF																													
25V	≤ 10%	0805 ≥ 1.0uF, C ≥ 4.7Uf																													
	≤ 14%	0603 ≥ 0.33uF																													
16V	≤ 10%	0402 ≥ 33nF, 0603 ≥ 0.15uF, 0805 ≥ 0.68uF, C ≥ 2.2uF																													
10V	≤ 15%	0402 ≥ 56nF, 0603 ≥ 0.33uF, C ≥ 2.2uF																													
Vr	D.F	Exception of D.F.																													
25V	≤ 10%	0603 ≥ 0.1uF, 0805 ≥ 0.33uF, 1206 ≥ 1.0 uF																													
	≤ 12.5%	0402 ≥ 0.047uF																													
16V	≤ 12.5%	0402 ≥ 0.047uF																													
14	Humidity (Damp Heat) Load	<p>*Test temp.: 40±2°C</p> <p>*Humidity: 90~95% RH</p> <p>*Test time: 500 hrs</p> <p>*Test Voltage : Rated Voltage ( Max 500V)</p> <p>*Measurement to be made after keeping at room temperature for 48±4 hrs.</p>	<p>*No remarkable damage</p> <p>*Cap. Change : NPO: ±7.5% or ±0.75 pF whichever is larger X7R/X5R: ≥ 10V: ±12.5%, 6.3V : ±25% Y5V: ±30%</p> <p>*Q value/D.F. <b>SAME AS No. 13</b></p>																												

## 8.Packing

8-1. Bulk Packaging: Packing code(B)

8-2. Tape Packing: please specify the packing code when ordering.

Packing code	Pcs/Reel	Reel size	
05	500	7"	
1	1000	7"	
2	2000	7"	
3	3000	7"	
T	4000	7"	
U	10000	0402	7"
		0603	10"
V	15000	13"	
W	20000	13"	

8-3. Appearance of taping

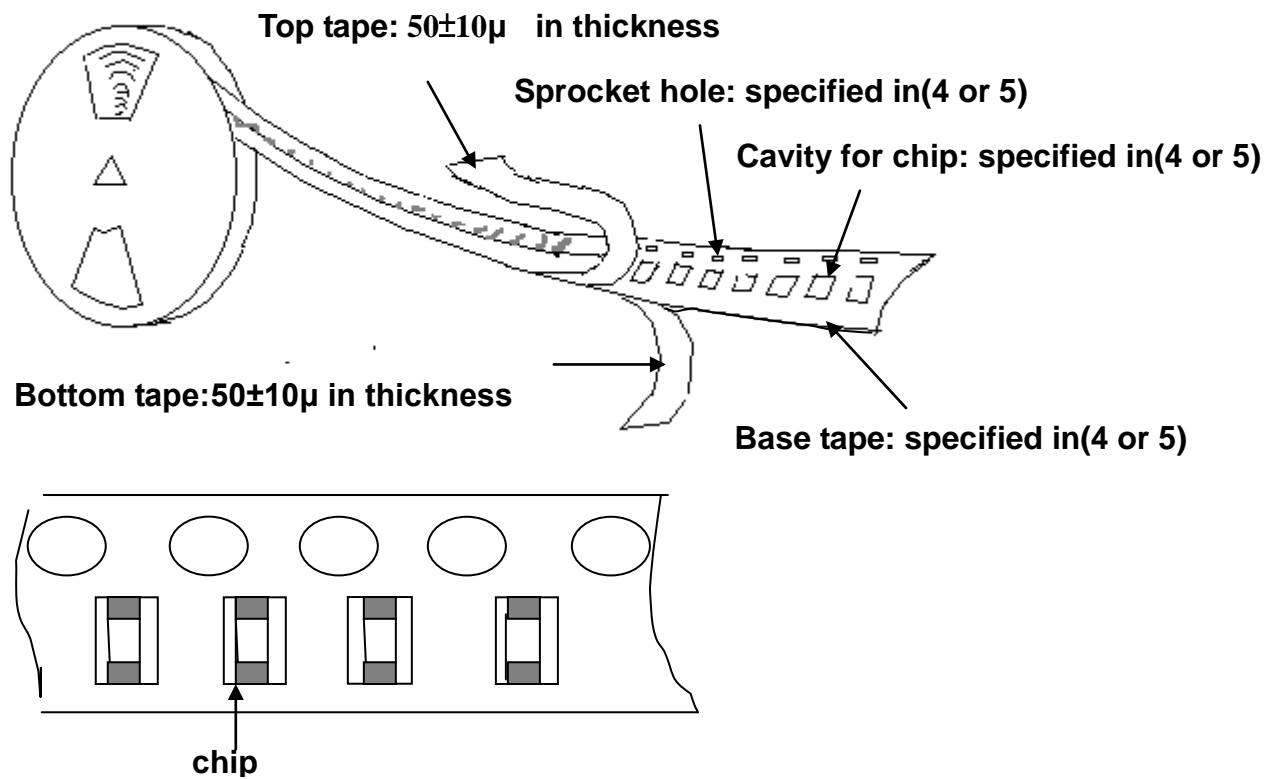

### 8-4 Dimensions of Paper Tape

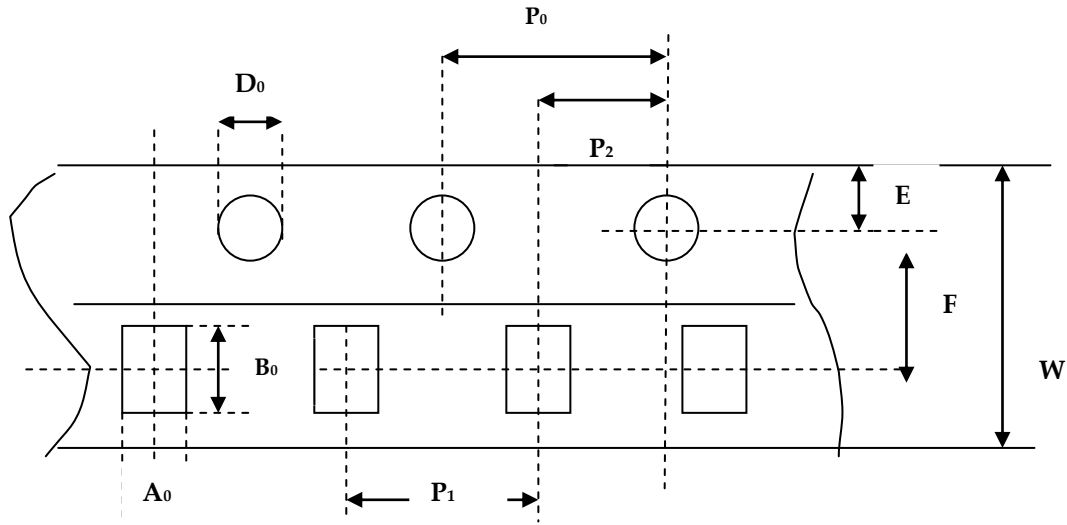

Unit: m/m

Chip size	0402	0603	0805	1206	Tolerance
<b>Mark</b>					
<b>A<sub>0</sub></b>	0.61	1.02	1.50	2.00	±0.1
<b>B<sub>0</sub></b>	1.10	1.82	2.30	3.50	±0.1
<b>W</b>	8.0	8.0	8.0	8.0	±0.3
<b>E</b>	1.75	1.75	1.75	1.75	±0.1
<b>F</b>	3.5	3.5	3.5	3.5	±0.05
<b>D<sub>0</sub></b>	1.55	1.55	1.55	1.55	±0.1
<b>P<sub>1</sub></b>	2.0	4.0	4.0	4.0	±0.05
<b>P<sub>2</sub></b>	2.0	2.0	2.0	2.0	±0.05
<b>P<sub>0</sub></b>	4.0	4.0	4.0	4.0	±0.05

Paper thickness: T:0.65±0.05 mm (for 0402 product)  
T:0.75±0.05 mm (for thickness code S)  
T:0.95±0.05 mm (for thickness code P, H)

- Note: (1) The top tape and bottom tape shall not protrude beyond the edges of the tape, and shall not cover sprocket holes.  
(2) Cumulative tolerance of sprocket holes 10 pitch : ±0.3mm

**8-5 Dimensions of Embossed Packing (plastic tape):**

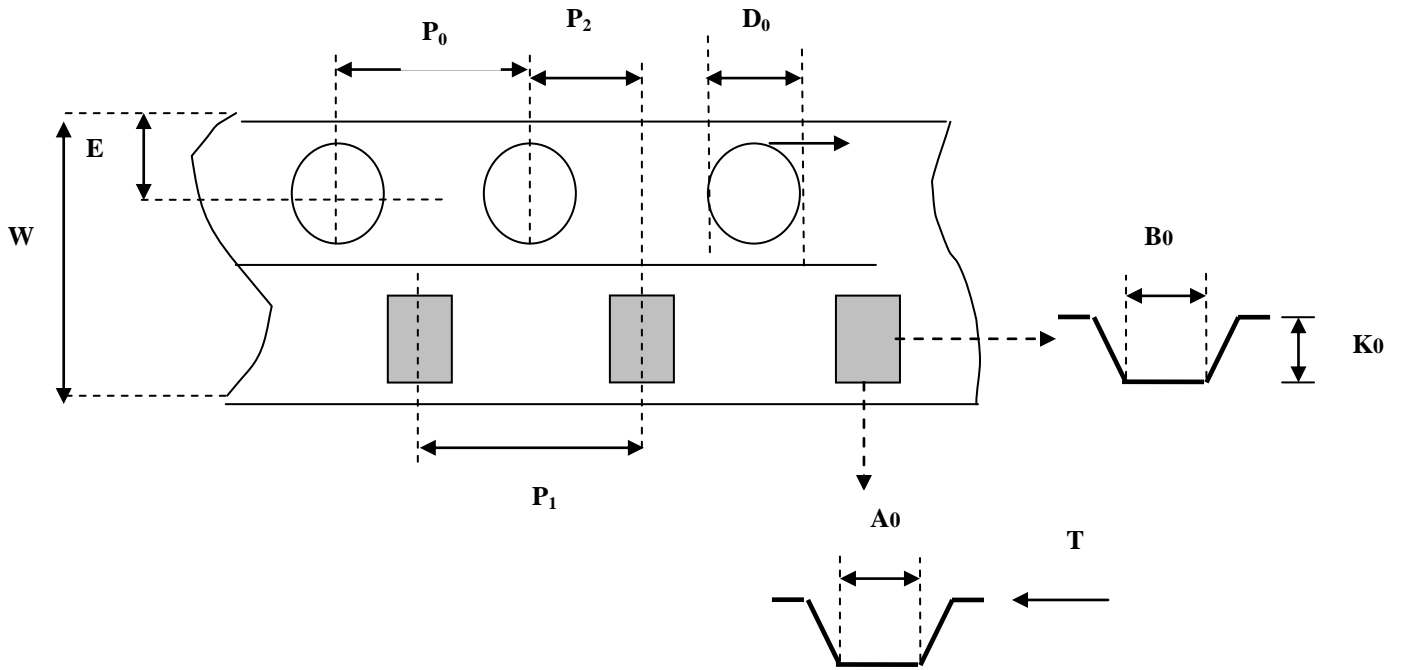

unit: m/m

Chip size	0805	1206	1210	1808	1812	1825	2220	2225
<b>Mark</b>								
<b>A<sub>0</sub></b>	1.65±0.2	2.00±0.2	2.80±0.2	2.40±0.2	3.60±0.2	<6.80	5.50±0.3	<6.80
<b>B<sub>0</sub></b>	2.40±0.2	3.60±0.2	3.60±0.2	4.90±0.3	4.90±0.3	<5.30	6.20±0.3	<6.50
<b>K<sub>0</sub></b>	2.50 max	2.50 max	3.00 max	2.50 max	4.0 max	<3.10	4.0 max	<3.10
<b>D<sub>0</sub></b>	1.55±0.1	1.55±0.1	1.55±0.1	1.55±0.1	1.55±0.1	1.50+0.10/-0	1.55±0.1	1.50+0.10/-0
<b>W</b>	8.00±0.2	8.0±0.2	8.0±0.2	12.0±0.2	12.0±0.2	12.0±0.20	12.0±0.2	12.0±0.20
<b>P<sub>1</sub></b>	4.00±0.1	4.00±0.1	4.00±0.1	4.00±0.1	8.00±0.1	8.00±0.10	8.0±0.1	8.00±0.10
<b>P<sub>2</sub></b>	2.00±0.1	2.00±0.1	2.00±0.1	2.00±0.1	2.00±0.1	2.00±0.05	2.0±0.1	2.00±0.05
<b>E</b>	1.75±0.1	1.75±0.1	1.75±0.1	1.75±0.1	1.75±0.1	1.75±0.10	1.75±0.1	1.75±0.10
<b>T</b>	0.23±0.05	0.23±0.05	0.23±0.05	0.23±0.05	0.25±0.1	0.30±0.10	0.25±0.1	0.30±0.10
<b>P<sub>0</sub></b>	4.00±0.1	4.00±0.1	4.00±0.1	4.00±0.1	4.00±0.1	4.00±0.10	4.00±0.1	4.00±0.10

**Emboss tape: for thickness code X, L, Z, G, U**

**8-6. Dimension of Reel.**

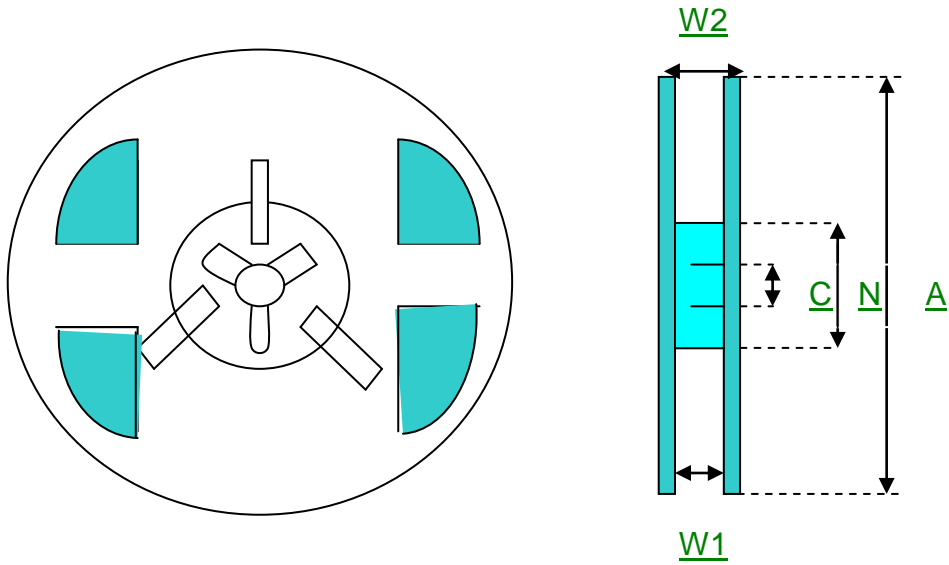

unit: m/m

Reel size	A	N	C	W1	W2(max.)
7" 0402~1210	178 ±0.5	60.5±1.0	13.0+0.5/-0.2	8.4+1.5/-0	14.4
7" 1812~2225	178 ±0.5	60.5±1.0	13.0+0.5/-0.2	12.4+2.0/-0	16.0
10"	250 ±0.5	100 ±1.0	13.0+0.5/-0.2	8.4+1.5/-0	14.4
13"	330 ±0.5	100 ±1.0	13.0+0.5/-0.2	8.4+1.5/-0	14.4

## 9.Soldering & Cleaning

### Recommended Soldering Profile (Prevention of thermal shock)

Figure.(I) IR reflow soldering profile for SMT process with SnAgCu series solder paste , (lead free type)

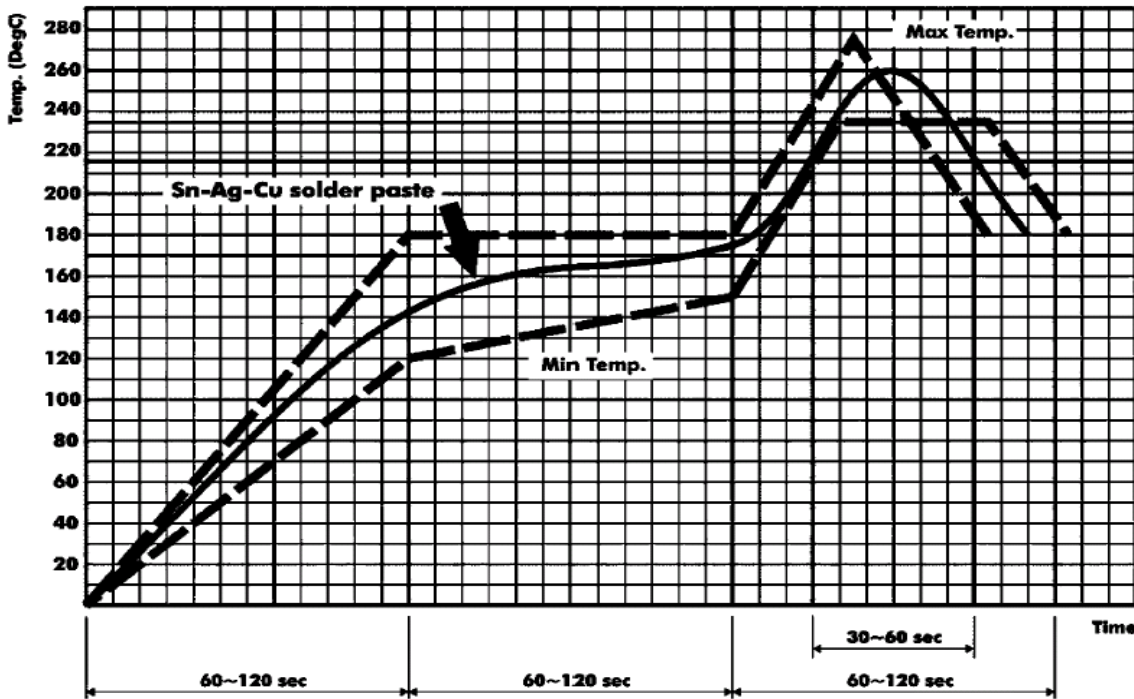
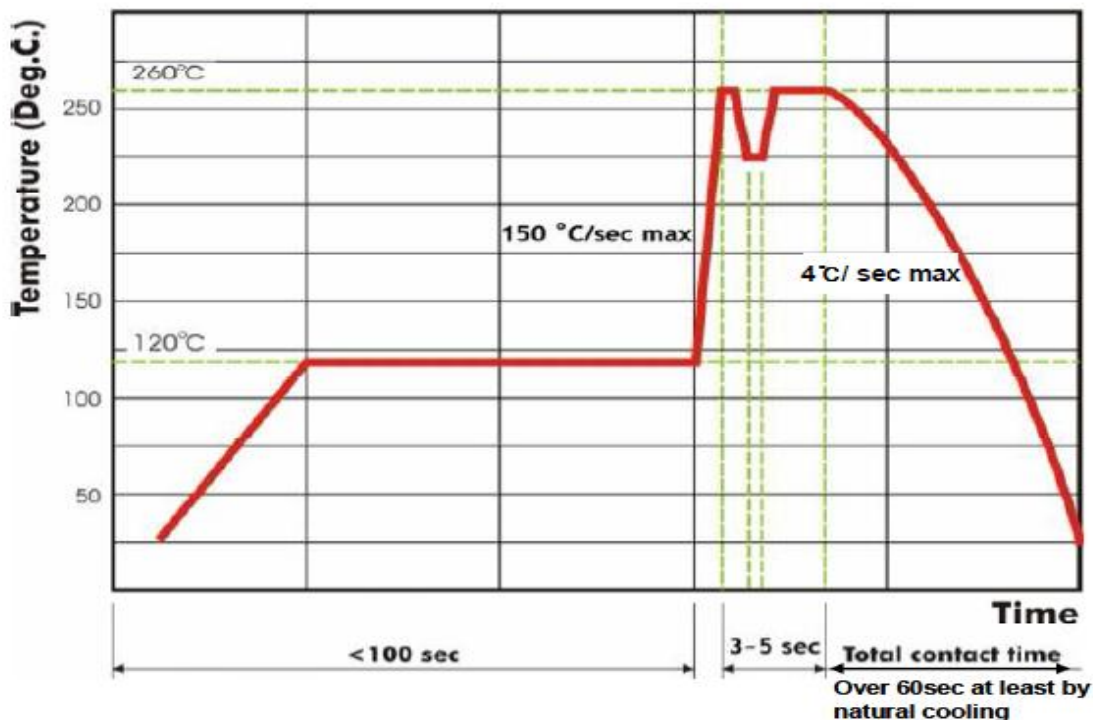

Figure. (II) Wave soldering profile for SMT process with SnAgCu series solder paste, (lead free type)  
**wave soldering is recommended only for the following size:**  
 0603(1608), 0805(2012) and 1206(3216) thickness < 1mm



### Cleaning :

All flux residues must be removed by using suitable electronic-grade vapor-cleaning solvents to eliminate contamination that could cause electrolytic surface corrosion. Goods results can be obtained by using ultrasonic cleaning of solvent. The choice of the proper system is depends upon many factors such as component mix, flux, and solder paste and assembly method. The ability of the cleaning system to remove flux residues and contamination from under the chips is very important.

## 10.Storage

1. To store products at +5 to 40°C ambient temperature and 40 to 60% related humidity conditions.(refer to JIS C 0806)
2. Although HITANO MLCC officially stated storage and shelf life is 2 years from the manufacturing date, we recommend using the products within six months of receipt. Check solder ability in case of shelf life extension is needed.
3. Please note that these are "recommended" storage conditions and parts can be stored outside these parameters without affecting solderability or short term reliability. However, components not stored as recommended may see issues such as solderability and tape and reel degradation where the paper tape may not separate as designed.

**Caution:**

- A. Don't store products in a corrosive environment such as sulfide, chloride gas, or acid. It may cause oxidization of electrode, which easily be resulted in poor soldering.
- B. To store products on the shelf and avoid exposure to moisture.
- C. Don't expose products to excessive shock, vibration, direct sunlight and so on.

## 11 Label

Company logo

Commodity

**HITANO**

CHIP CAPACITORS

Part No: 0805B104K500NT



HITANO part no. ( Bar Code 128 )

Q'TY.: 4000 pcs



Q'ty of the reel ( Bar code 128 )

Lot No: 60AS5AP18



Logo of Rohs compliant

Cust P/N:

2006/10/13  
MADE IN TAIWAN

Date code

Lot No. Customer part no. ( If any )



## 12. PCB design

Chip components are susceptible to board stress since the component itself is mounted directly on the board. They are also sensitive to mechanical and thermal stress when solder, which may cause chip cracked.

Please take solder form and component layout into consideration to eliminate stress.

### 12.1. Pattern form

#### (1) Placing of chip components and component.

incorrect

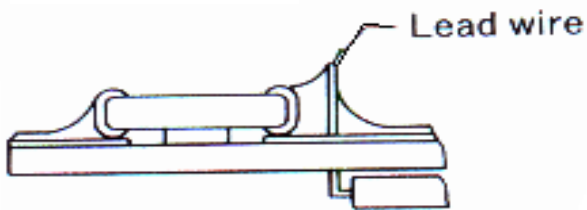

correct

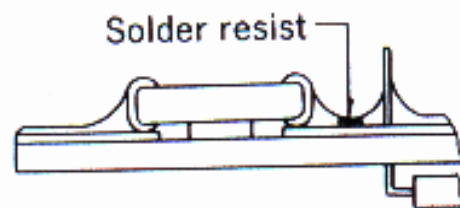

#### (2) Placing close to chassis.

incorrect

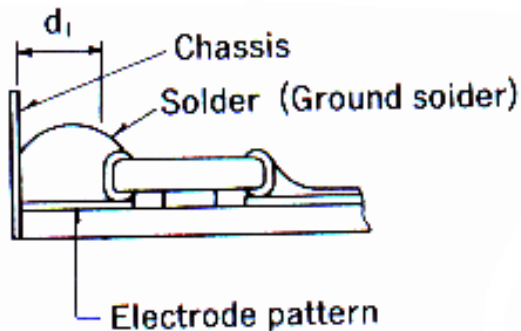

correct

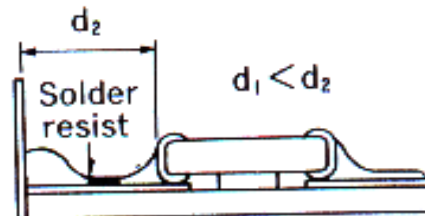

#### (3) Placing leaded components after chip component.

incorrect

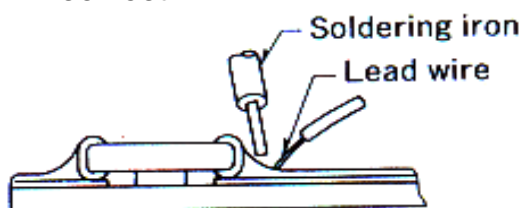

correct

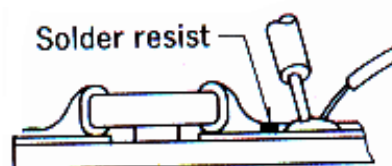

**(4) Lateral mounting**

**incorrect**

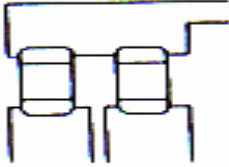

**correct**

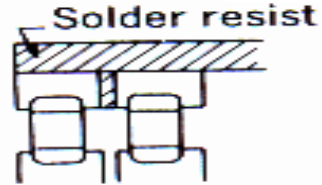

**12-2. Component direction**

To design a mounting position that minimizes the stress imposed on the chip during flexing or bending of the board.

(1) put the component lateral to the direction in which stress acts.

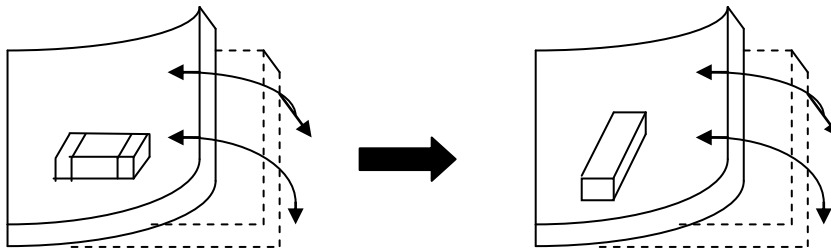

(2) Component layout close to board separation point.  
Susceptibility to stress in the order:  $A > C > B = D$

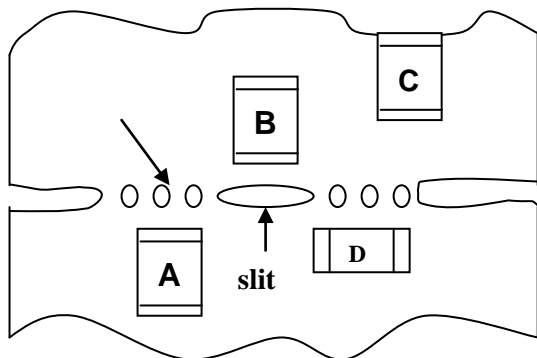

### 12.3. Land Pattern

When capacitors are mounted on P.C. board, the amount of solder directly affect the performance of capacitors. Therefore, the following items should be carefully considered in the design of solder land pattern.

- (1) The greater the amount of solder, the higher the stress on the chip capacitors, and lead to cracking and breaking likely. It is necessary the appropriate size and configuration of the solder pads should be designed to have proper amount of solder on the termination.
- (2) When two or more capacitors are soldered together onto the same land or pad, the pad must be designed so that each capacitor's soldering point is separated by solder-resist.

The following diagram and table for recommended pad dimensions.

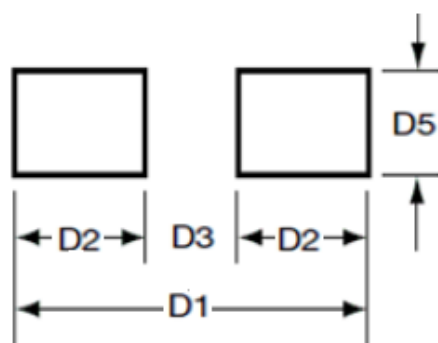

Dimensions in millimeters

Type	0201	0402	0603	0805	1206	1210	1808	1812	1825	2220	2225
D1	0.65	1.50	2.30	2.80	4.00	4.00	5.40	5.30	5.30	7.00	7.00
D2	0.21	0.50	0.80	0.90	0.90	0.90	1.05	0.90	0.90	1.35	1.35
D3	0.23	0.50	0.70	1.00	2.20	2.20	3.30	3.50	3.50	4.30	4.30
D5	0.30	0.50	0.80	1.30	1.60	2.50	2.30	3.80	6.50	5.00	6.50

Unit: mm