

MD SERIES

ORDERING INFORMATION

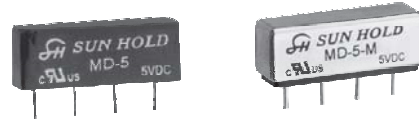
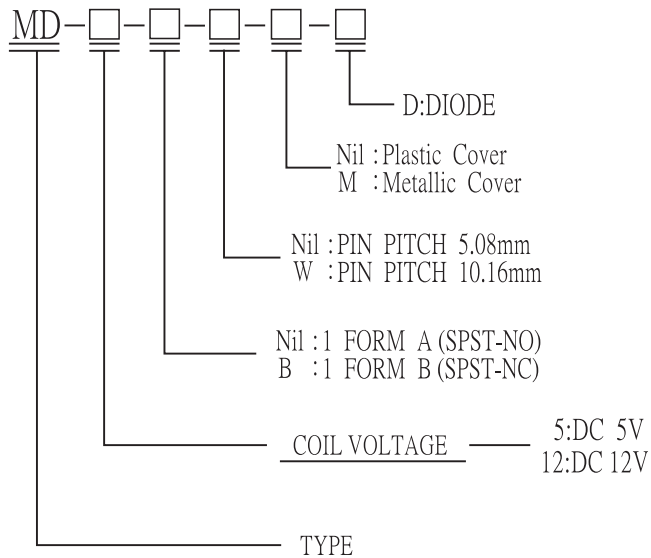

FEATURES:

- SIP Reed Relay.
- Plastic and Metals all available.
- Completely washable.
- Surge strength 1,500 VDC (between coil & contact).
- Provide high speed, miniature and cost effective switching solution.

COIL RATING(at 20°C)

NOMINAL VOLTAGE (VDC)	COIL RESISTANCE (Ω)(±10%)	POWER CONSUMPT -ION(W)	NOMINAL CURRENT (mA)(±10%)	PULL IN VOLTAGE (VDC)	DROP OUT VOLTAGE (VDC)	MAX. ALLOWABLE VOLTAGE (VDC)
5V	500 Ω	0.05W	10.0mA	3.75V	0.8V	10V
12V	1000 Ω	0.144W	12.0mA	9.00V	1.2V	20V

PERFORMANCE(at initial value)

Item	Type	0.5A
Contact Resistance		150mΩ Max. (Initial value)
Operate Time		0.5msec Max.
Release Time		0.1msec Max.
Dielectric Strength between coil& contact between contact		DC1500V (1min) DC250V (1min)
Insulation Resistance		100mΩ Max. (DC500V)
Operating Ambient Temperature		-40°C~ +85°C
Humidity		35 to 85% RH
Vibration Resistance		10G (10~55Hz)(Dual amplitude:1.5mm)
Shock Resistance		10G
Life Expectancy Mechanically Electrically		100,000,000 ops. Min.(1800 ops./h) 100,000 ops. Min.(0.5A 20VDC,0.1A100VDC,0.5A20VAC,0.1A100VAC, resistive load 1200 ops./h) 50,000,000 ops. Min. (5VDC,10mA, resistive load1200 ops./h)
Weight		1.6g(approx.)

CONTACT RATING

Item \ Type	0.5A
Rated Carrying Current	DC20V 0.5A AC20V 0.5A DC100V 0.1A AC100V 0.1A
Max. Allowable Current	1A
Max. Allowable Voltage	DC100V AC100V
Max. Current (continual)	0.5A
Max. Switching Power	10W,10VA
Max. Switching Voltage	DC200V
Max. Switching Current	0.5A
Contact Material	Ruthenium

DIMENSIONS(Unit:mm)

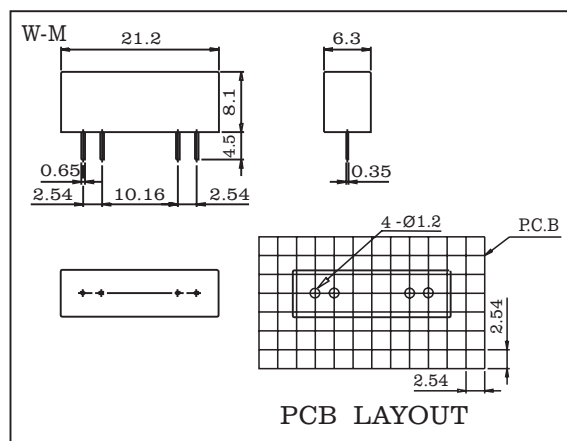
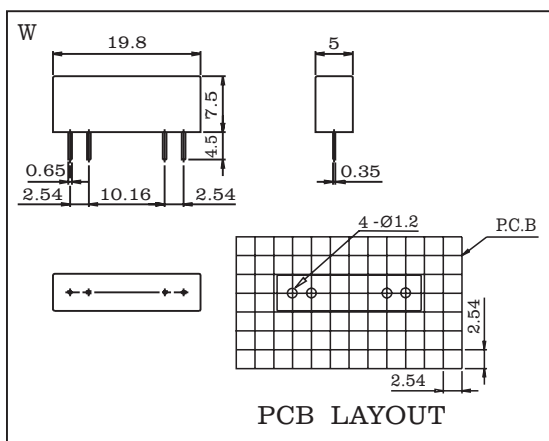
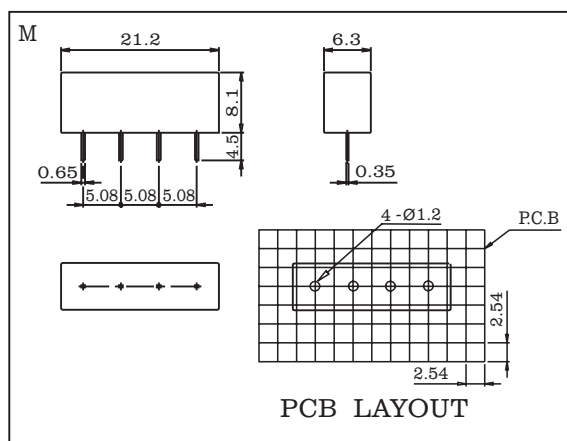
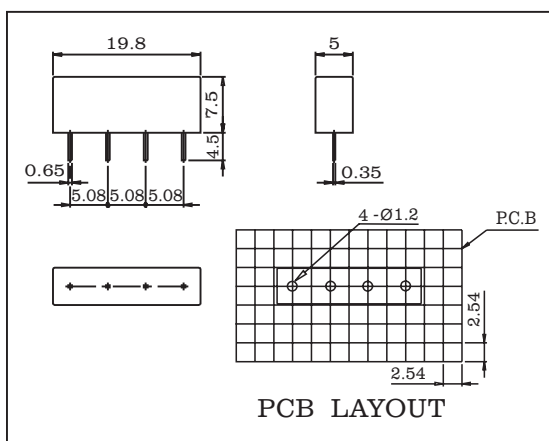

WIRING DIAGRAMS(Bottom View)

