

THU SERIES

ORDERING INFORMATION

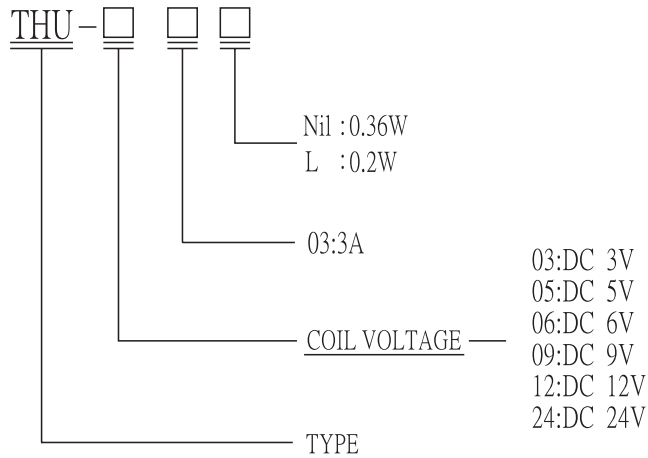

FEATURES:

- UL & CUL safety approval.
- Subminiature single pole Relay.
- Standard (360mw) & High sensitive (201mw) type.
- Plastic sealed type is prepared for washing procedure.

COIL RATING(at 20°C)

NOMINAL VOLTAGE (VDC)	COIL RESISTANCE (Ω)(±10%)	POWER CONSUMPT -10N(W)	NOMINAL CURRENT (mA)(±10%)	PULL IN VOLTAGE (VDC)	DROP OUT VOLTAGE (VDC)	MAX ALLOWABLE VOLTAGE (VDC)
3V	25Ω	0.36W	120mA	70% MAX.	10% MIN.	130%
5V	69Ω		72mA			
6V	100Ω		60mA			
9V	225Ω		40mA			
12V	400Ω		30mA			
24V	1600Ω		15mA			

	NOMINAL VOLTAGE (VDC)	COIL RESISTANCE (Ω)(±10%)	POWER CONSUMPT -10N(W)	NOMINAL CURRENT (mA)(±10%)	PULL IN VOLTAGE (VDC)	DROP OUT VOLTAGE (VDC)	MAX ALLOWABLE VOLTAGE (VDC)
L	3V	45Ω	0.2W	66.7mA	70% MAX.	10% MIN.	130%
	5V	120Ω		41.7mA			
	6V	180Ω		33.3mA			
	9V	400Ω		22.5mA			
	12V	700Ω		17.0mA			
	24V	2800Ω		8.6mA			

PERFORMANCE(at initial value)

Item	Type	3A
Contact Resistance		50mΩ Max. (Initial value)
Operate Time		5msec Max.
Release Time		5msec Max.
Dielectric Strength between coil & contact between contact		AC1500V(1min) AC1000V(1min)
Insulation Resistance		100MΩ Min.(DC500V)
Operating Ambient Temperature		-30°C~+85°C
Humidity		35 to 85% RH
Vibration Resistance		10G (10~55Hz)(Dual amplitude:1.5mm)
Shock Resistance		10G
Life Expectancy Mechanically Electrically		10,000,000 ops. Min.(1800 ops./h) 100,000 ops. Min.(1200 ops./h)
Weight		3.5g(approx.)

CONTACT RATING

Item \ Type	3A
Rated Carrying Current	DC24V 3A DC30V 1A AC120V 2A
Max. Allowable Current	3A
Max. Allowable Voltage	AC 120V DC 60V
Max. Current(continual)	3A
Min. Load	DC5V 10mA
Contact Material	Ag alloy

DIMENSIONS(Unit:mm)

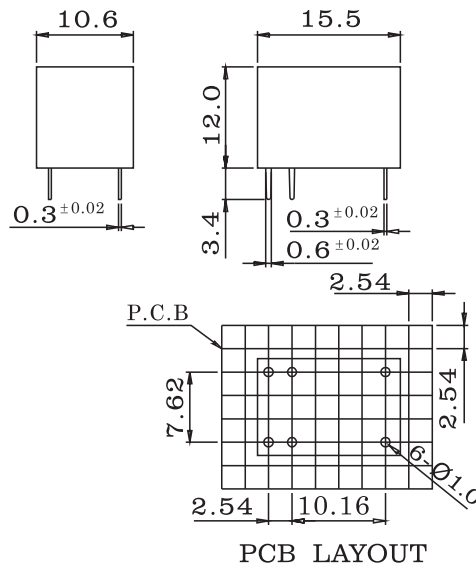

WIRING DIAGRAMS(Bottom View)

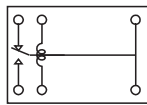

REFERENCE DATA

