

TR-72D-WMB

Transceiver Module for Wireless M-Bus

Data Sheet



Description

TR-72D-WMB is a family of IQRF transceivers intended for Wireless M-Bus. It operates in the 868 MHz license free ISM (Industry, Scientific and Medical) frequency band. Its highly integrated ready-to-use design requires no external components. Extra low power consumption predetermines these modules for battery powered applications.



Key features

- Embedded Wireless M-Bus protocol, without operating system
- Wireless M-Bus EN 13757-4:2005 modes S1, T1, S2 and T2
- UART ↔ Wireless M-Bus converter
- UART pins: RX and TX
- RF band 868 MHz
- FSK modulation
- RF output power 12.5 mW
- Serial EEPROM 256 Kb
- +3 V LDO regulator output
- 2 LEDs
- Antenna options: on-board antenna, U.FL connector or soldering antenna pad-hole
- SIM card format
- Shielding can
- Extra low power consumption

Applications

- Wireless M-Bus
- Telemetry
- Automated meter reading (AMR)
- Heat, electricity, gas and water meters

Block diagram

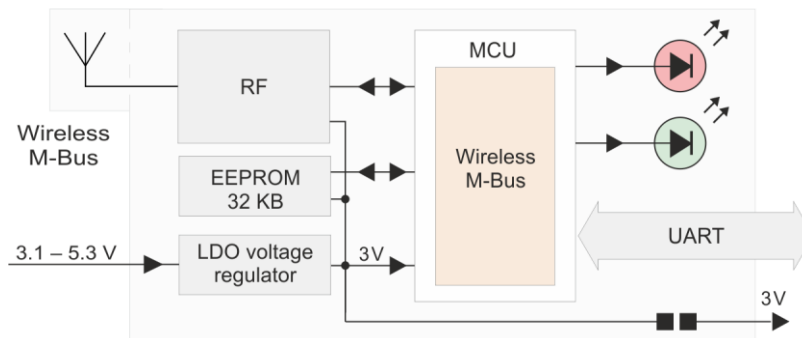

Information contained in this publication regarding device applications and the like is provided only for your convenience and may be superseded by updates. It is your responsibility to ensure that your application meets with your specifications.

MICRORISC MAKES NO REPRESENTATIONS OR WARRANTIES OF ANY KIND TO STATED CONDITION, QUALITY, PERFORMANCE, MERCHANTABILITY OR FITNESS FOR PURPOSE and disclaims all liability arising from this information and its use. Use of MICRORISC devices in life support and/or safety applications is entirely at the buyer's risk, and the buyer agrees to defend, indemnify and hold harmless MICRORISC from any and all damages, claims, suits, or expenses resulting from such use. No licenses are conveyed, implicitly or otherwise, under any MICRORISC intellectual property rights.

Electrical specifications

Typical values *unless otherwise stated*

Parameters specified in this datasheet are typical values. They are at power supply $V_{OUT} = 3\text{ V}$ only. V_{OUT} voltage different from 3 V can impact on RF range and other parameters.

Supply voltage (V_{CC})	3.1 V to 5.3 V
LDO output (V_{OUT})	+3 V \pm 60 mV ($V_{CC} > 3.1\text{ V}$), 100 mA max.
Operating temperature ¹	-40 °C to +85 °C
Supply current	
Sleep mode	1 μ A (Pin C8 must be at logic high level)
Run mode	6.2 mA
Additional LED supply current	About 2 mA per LED. Rough value for brief guidance only.
RX mode	10 mA (RF IC in RX mode, MCU in sleep mode)
TX mode	8 mA – 22 mA (according to RF output power)
Nominal frequency	868.30 and 868.95 MHz
RF data modulation	FSK (Frequency Shift Keying)
RF data transmission bit rate	32.768 kb/s (mode S) or 100 kb/s (mode T)
RFIC RF sensitivity	104.3 dBm (mode T), 104.5 dBm (mode S)
RFIC RF output power	Up to 9.1 dBm (mode T), 11.3 dBm (mode S), programmable in 8 steps
RF range (TR-72DA-WMB) ²	Up to 320 m (mode T), 365 m (mode S)
UART interface	Bit rate 19200 Bd, Data bits: 8, Parity: none, Stop bit: 1, Flow control: none
Input voltage on C5 and C8 pins	0 V to V_{OUT}
Size (L x W x H)	25.0 mm x 14.9 mm x 2.0 mm (TR-72Dx-WMB) 31.8 mm x 14.9 mm x 2.0 mm (TR-72Dax-WMB)

Note 1: RF range may change with lower temperature. Frost, condensation or humidity over 85% may disable transceiver functionality. Transceiver suitability should be tested in final application before volume use.

Note 2: RF range strongly depends on transceiver orientation and surroundings.

Caution: Electrostatic sensitive device. Observe appropriate precautions for handling.

Absolute maximum ratings

Stresses above listed maximum values may cause permanent damage to the device and affect device reliability. Functional operation at these or any other conditions beyond those specified is not supported.

Supply voltage (V_{CC})	5.5 V
Voltage on C5 and C8 pins vs. GND	-0.3 V to ($V_{OUT} + 0.3\text{ V}$)
Storage temperature	-40 °C to +85 °C
Ambient temperature under bias	-40 °C to +85 °C

Simplified schematic

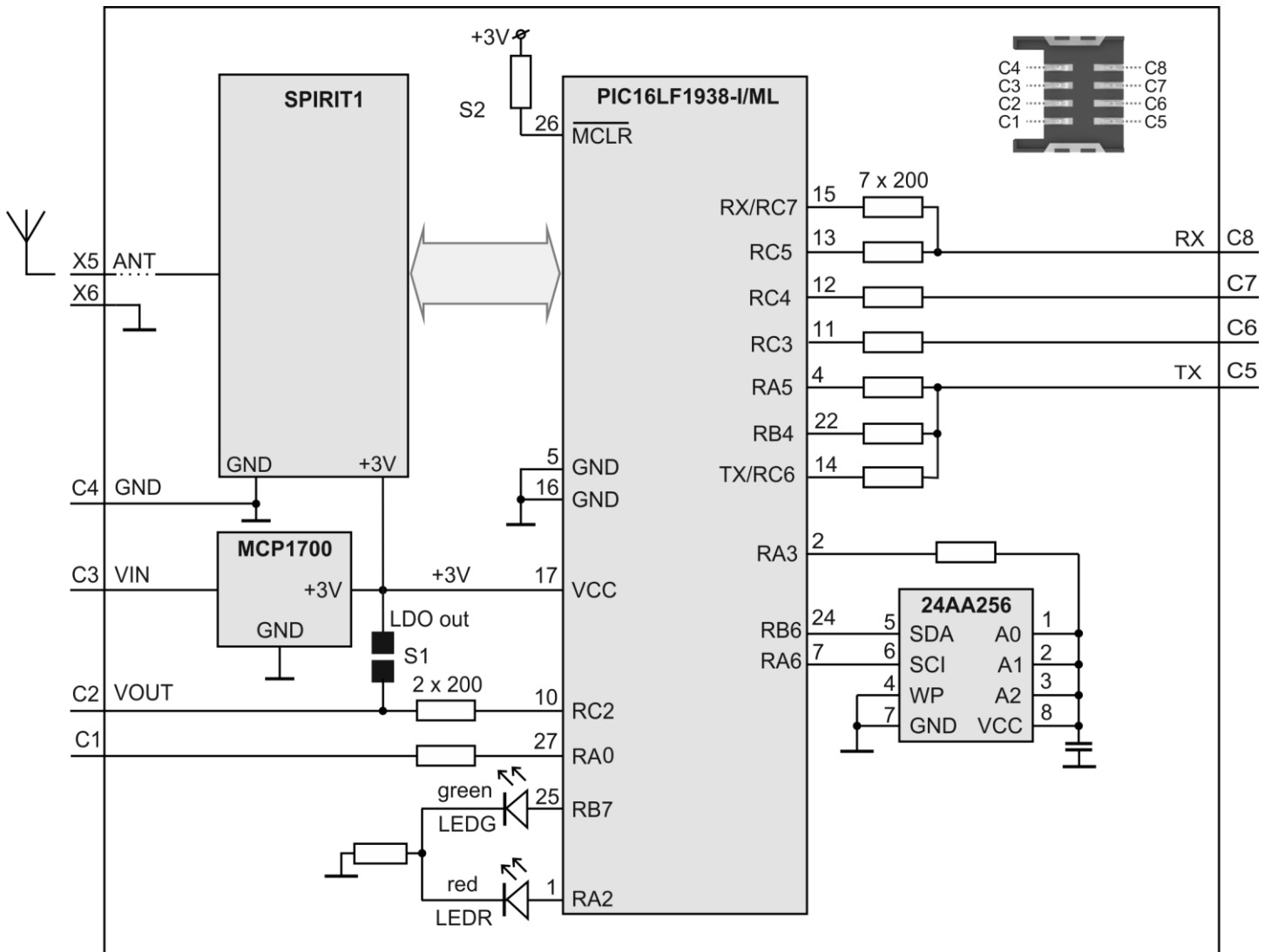

Basic components

IC	Type	Manufacturer	Note
MCU	PIC16LF1938-I/MV	Microchip	
RF IC	SPIRIT1	STMicroelectronics	
RF balun	BALF-SPI-01D3	STMicroelectronics	
LDO voltage regulator	MCP1700T-3002E/TT	Microchip	
EEPROM	24AA256-I/CS16K	Microchip	256 Kb

For more information refer to datasheets of ICs used.

Pin	Name	Description
C1		Do not use, leave unconnected
C2	V _{OUT}	On-board +3 V LDO output (if S1 pads interconnected)
C3	V _{IN}	Power supply voltage
C4	GND	Ground
C5	TX	UART TX
C6		Do not use, leave unconnected
C7		Do not use, leave unconnected
C8	RX	UART RX . Must be in log. H in idle state.
X5	ANT	Antenna input (TR-72D-WMB only)
X6	GND	Ground (TR-72D-WMB only)
P1–P5		For manufacturer only. Do not use, leave unconnected.
S1		LDO output enable. Interconnect to enable (default disabled).

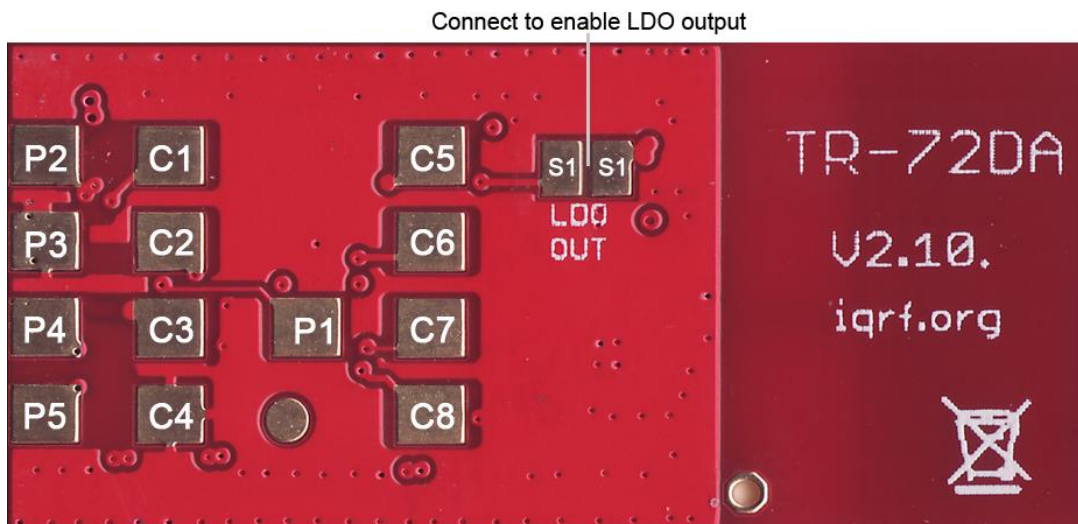

Bottom view

Application

Firmware

Firmware of the MCU inside the TR-72Dx-WMB transceiver can be upgraded at the user through the PC utility (see below) by the FW possibly released by the factory.

Typical usage

Refer to *Wireless M-Bus Implementation in TR-7xD-WMB User's guide*.

Meter and MUC

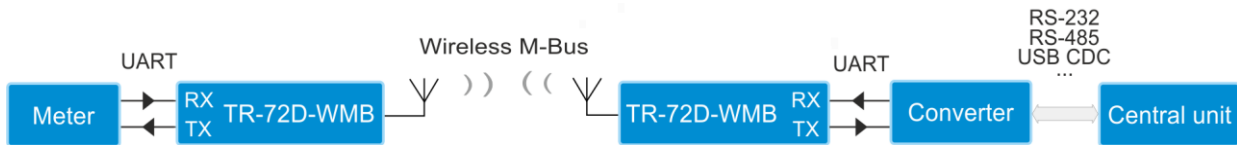

Compact implementation using the GW-USB-06-WMB device

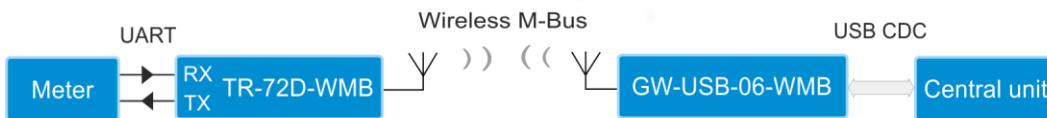

Sniffer

The wM-Bus Sniffer allows to monitor wM-Bus communication.



PC software

To configure parameters and control wM-Bus devices in all Meter, MUC and Sniffer modes from PC, the `wMBUS-Utility_XXXXXX.exe` utility is provided. It is also intended for device configuration, wM-Bus communication testing and upgrade of FW inside the TR transceiver.

Product information

Ordering codes

TR - 7 2 D A - WMB

└─── Antenna options:

nil - Soldering pad-hole (no antenna, no antenna connector)

A - On-board PCB antenna

C - U.FL connector (mini coax)

Type	Antenna option
TR-72D-WMB	Soldering pad-hole
TR-72DC-WMB	U.FL connector
TR-72DA-WMB	On-board PCB antenna

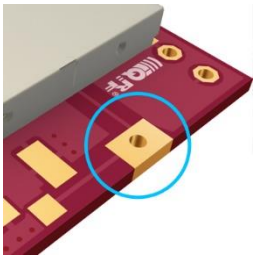

TR-72D-WMB

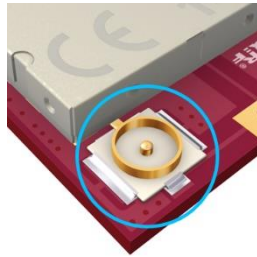

TR-72DC-WMB

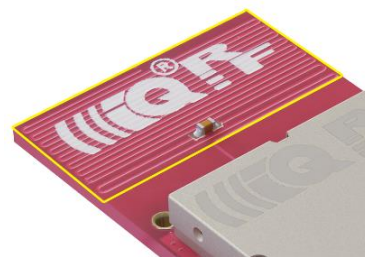

TR-72DA-WMB

Document history

- 161124 Several minor improvements.
- 151209 First release.

Sales and Service

Corporate office

MICRORISC s.r.o., Prumyslova 1275, 506 01 Jicin, Czech Republic, EU
Tel: +420 493 538 125, Fax: +420 493 538 126, www.microrisc.com.

Partners and distribution

Please visit www.iqrf.org/partners.

Quality management

ISO 9001 : 2009 certified

Complies with ETSI directives EN 301489-1 V1.9.2:2011, EN 301489-3 V1.6.1:2013,
EN 300220-1 V2.4.1:2012, EN 300220-2 V2.4.1:2012 and VO-R/10/05.2014-3.

Complies with directives 2011/65/EU (RoHS) and 2012/19/EU (WEEE).



Trademarks

The IQRF name and logo and MICRORISC name are registered trademarks of MICRORISC s.r.o.
PIC, SPI, Microchip and all other trademarks mentioned herein are property of their respective owners.

Legal

All information contained in this publication is intended through suggestion only and may be superseded by updates without prior notice. No representation or warranty is given and no liability is assumed by MICRORISC s.r.o. with respect to the accuracy or use of such information.

Without written permission it is not allowed to copy or reproduce this information, even partially.

No licenses are conveyed, implicitly or otherwise, under any intellectual property rights.

The IQRF® products utilize several patents (CZ, EU, US)

On-line support: support@iqrf.org



Smarter wireless. Simply.