

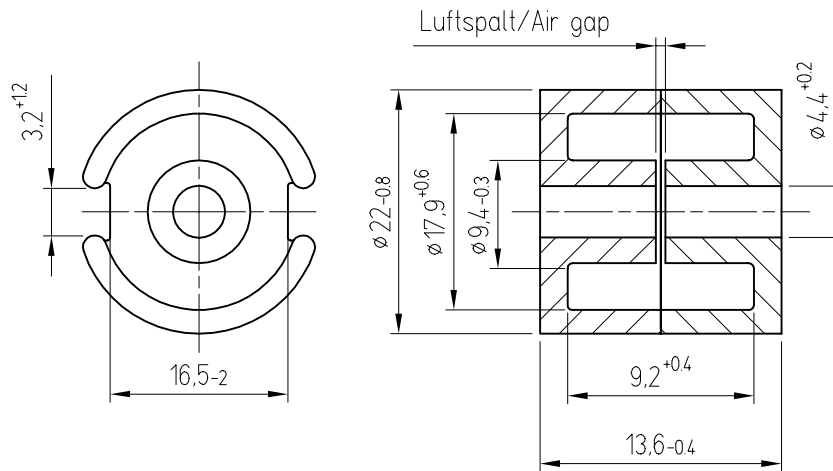

Schalenkern SK 22 x 13
Pot core SK 22 x 13



128

Magn. Formkenngrößen/Satz / eff. magn. parameters/set

Formfaktor / core factor	C_1	=	0,48	mm ⁻¹
Eff. magn. Weglänge / eff. magn. path length	l_e	=	31,2	mm
Eff. magn. Querschnitt / eff. magn. cross section	A_e	=	64,8	mm ²
Eff. magn. Volumen / eff. magn. volume	V_e	=	2020	mm ³
Gewicht / weight	G	≈	14,0	g

A_L -Wert A_L value nH	Toleranz tolerance	Werkstoff material	Luftspalt airgap mm	μ_e	Bestellnummer order number
3800	± 25%	K 2006	-	≈ 1500	326 220000 026
3850	± 25%	K 2005	-	≈ 1530	326 220000 025
6400	± 25%	K 4000	-	≈ 2550	326 220000 004
9000	± 25%	K 6000	-	≈ 3580	326 220000 006
630	± 5%	K 2005	≈ 0,10	≈ 250	326 220630 025
400	± 3%	K 2005	≈ 0,16	≈ 160	326 220400 025
250	± 3%	K 2005	≈ 0,28	≈ 100	326 220250 025