

Specifications

Current Rating: 3A AC,DC  
 Contact Resistance: 13mΩ Max  
 Insulation Resistance: 1000MΩ Min  
 Withstanding Voltage: 1000V AC/minute  
 Temperature Range: -55°C ~ +105°C  
 Material  
 Insulator: P.B.T, UL94V-0  
 Contact: Copper Alloy  
 Shell: STEEL

ORDER INFORMATION



V	S	X	1	-	F	XX	X	X	X
D-SUB Type	Solder Type	RoHS + P.B.T			Female	No. of Contacts	N:Nickel Shell T:Tin Shell	W:White Insulator B:Black Insulator	
G0:Gold Flash		S0:Selective Flash				A:Non Accessories			
G1:Gold 3u"		S1:Selective 3u"				B:Front Rivet #4-40, Height=5.8			
G2:Gold 5u"		S2:Selective 5u"				C:Front Rivet M3, Height=5.8			
G3:Gold 10u"		S3:Selective 10u"				D:Rear Rivet #4-40, Height=5.8			
G4:Gold 15u"		S4:Selective 15u"				E:Rear Rivet M3, Height=5.8			
G5:Gold 30u"		S5:Selective 30u"							

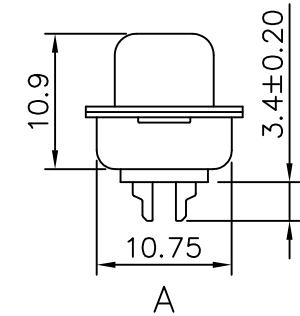
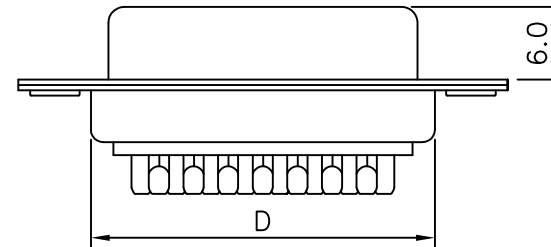
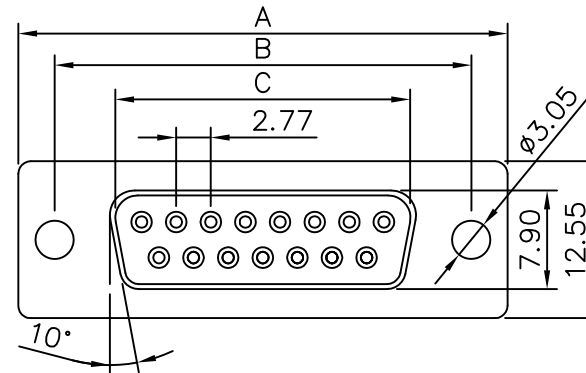
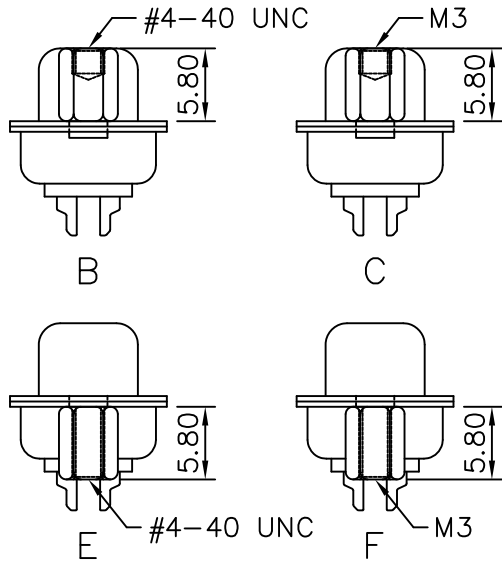

Positions	A	B	C	D
9	30.81	24.99	16.60	19.10
15	39.14	33.32	24.90	27.70
25	53.04	47.04	38.33	41.50
37	69.32	63.50	53.12	57.30

			<b>MCT</b>		品號 PART NO.	VSX1-FXXXXXX	日期 DATA	2008/05/12		
					圖號 DRAWING NO.	VSX1-FXXXXXX	繪圖 DRAWN	Sayid		
					客戶品號 CUSTOMER P/N		核對 APPROVED	Max		
REV.	DESCRIPTION	DATA	TITLE: D-SUB Solder Type	REV. A	公差 TOLERANCE	.X ±0.25 .XX ±0.20	比例 SCALE	FREE	單位 UNIT	mm