

## RN52 Bluetooth® Audio Module

### Features

- Fully qualified Bluetooth version 3.0 module,
- Fully compatible with Bluetooth version 2.1+EDR, 1.2 and 1.1
- Embedded Bluetooth profiles: A2DP, AVRCP, HFP/HSP and SPP
- Audio decoders: SBC, AAC, aptX
- Enhanced hands free voice capability narrowband and wideband codecs with cVc DSP
- Software configurable through commands over UART console interface
- Stereo analog differential audio output and input for highest quality audio
- External Audio CODECs Supported via S/PDIF and I2S Interface
- Integrated Amplifier for Driving 16Ω Speakers
- Dedicated GPIO pins enable MCUs to access control and status functions efficiently
- SPP data connection interface over UART
- Supports wireless iAP profile advertising which is discoverable by iOS devices (iAP protocol implementation on an external host microcontroller required)
- Certifications: FCC, ISED, CE, Bluetooth SIG
- Postage Stamp sized form factor: 13.5 x 26.0 x 2.7 mm
- Castellated SMT pads for easy and reliable PCB mounting
- Environmentally Friendly, RoHS Compliant
- Bluetooth SIG QDID 58578

### Applications

- High-quality wireless stereo headsets
- Automotive hands free audio kits
- Wireless audio docking station for smartphones
- High-quality wireless speakers
- VoIP handsets
- Remote control for media player
- Medical data devices



### RN52 Block Diagram

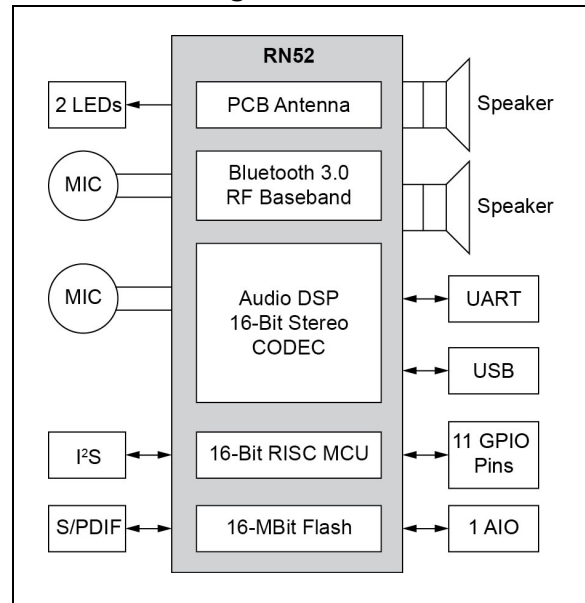

# RN52

## 1.0 DEVICE OVERVIEW

Microchip's RN52 Bluetooth audio module provides a highly integrated solution for delivering high-quality stereo audio in a small form factor. It combines a class 2 Bluetooth radio with an embedded DSP processor. The module is programmed and controlled with a simple ASCII command set.

The RN52 module complies with Bluetooth specification version 3.0. It integrates an RF radio and a baseband controller making it a complete Bluetooth subsystem. The RN52 supports a variety of profiles including A2DP, AVRCP, HSP/HFP, SPP and iAP. It provides a UART interface, several user programmable I/O pins, stereo speaker outputs, microphone inputs, digital audio interface and a USB port. Standard RN52 and its variants support A2DP, AVRCP, HFP, SPP and

iAP in the capacity of Bluetooth Peripheral role. RN52SRC supports A2DP, AVRCP, HFP in the capacity of the Bluetooth Central role.

RN52 supports wireless iAP profile advertising which is discoverable by iOS devices. An external host microcontroller is required to implement the iAP protocol and communicate with the authentication coprocessor while using the RN52 as a data pipe only to transfer the iAP protocol data over Bluetooth back and forth with the Apple device. A PIC<sup>®</sup> microcontroller can be used to implement the iAP protocol using the Microchip MFi Library.

[Table 1-1](#) provides the general specifications for the module. [Table 1-2](#) and [Table 1-3](#) provide the module's weight, dimensions and electrical characteristics.

**TABLE 1-1: GENERAL SPECIFICATIONS**

Specification	Description
Standard	Bluetooth <sup>®</sup> 3.0, class 2
Frequency Band	2.4 ~ 2.48 GHz
Modulation Method	GFSK, PI/4-DQPSK, 8 DPSK
Maximum Data Rate	3 Mbps
RF Input Impedance	50 ohms
Interface	UART, GPIO, AIO, USB, I2S, S/PDIF, speaker, microphone
Operation Range	10 meters (33 feet)
Sensitivity	-85 dBm at 0.1 % BER
RF TX Power	4 dBm

**TABLE 1-2: WEIGHT AND DIMENSIONS**

Specification	Description
Dimensions	26.0 mm x 13.5 mm x 2.7 mm
Weight	1.2 g

**TABLE 1-3: ELECTRICAL CHARACTERISTICS**

Specification	Description
Supply Voltage	3.0-3.6V DC
Working current	Depends on profiles, 30 mA typical
Standby current (disconnected)	< 0.5 mA
Temperature	-40°C to +85°C
ESD	JESD22-A224 class 0 product
Humidity	10% ~ 90% non-condensing

[Figure 1-1](#) shows the module's dimensions and [Figure 1-2](#) shows recommended landing pattern and layout.

**FIGURE 1-1: MODULE DIMENSIONS**

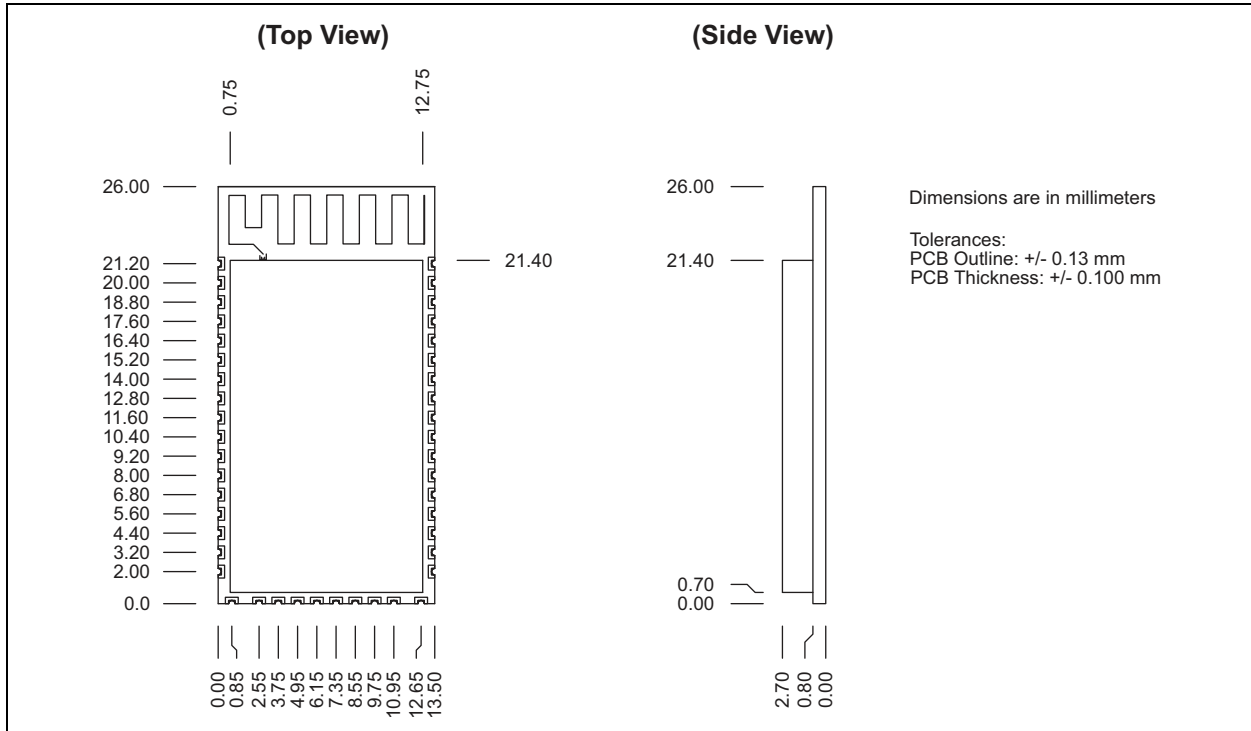

**FIGURE 1-2: RECOMMENDED PCB FOOTPRINT**

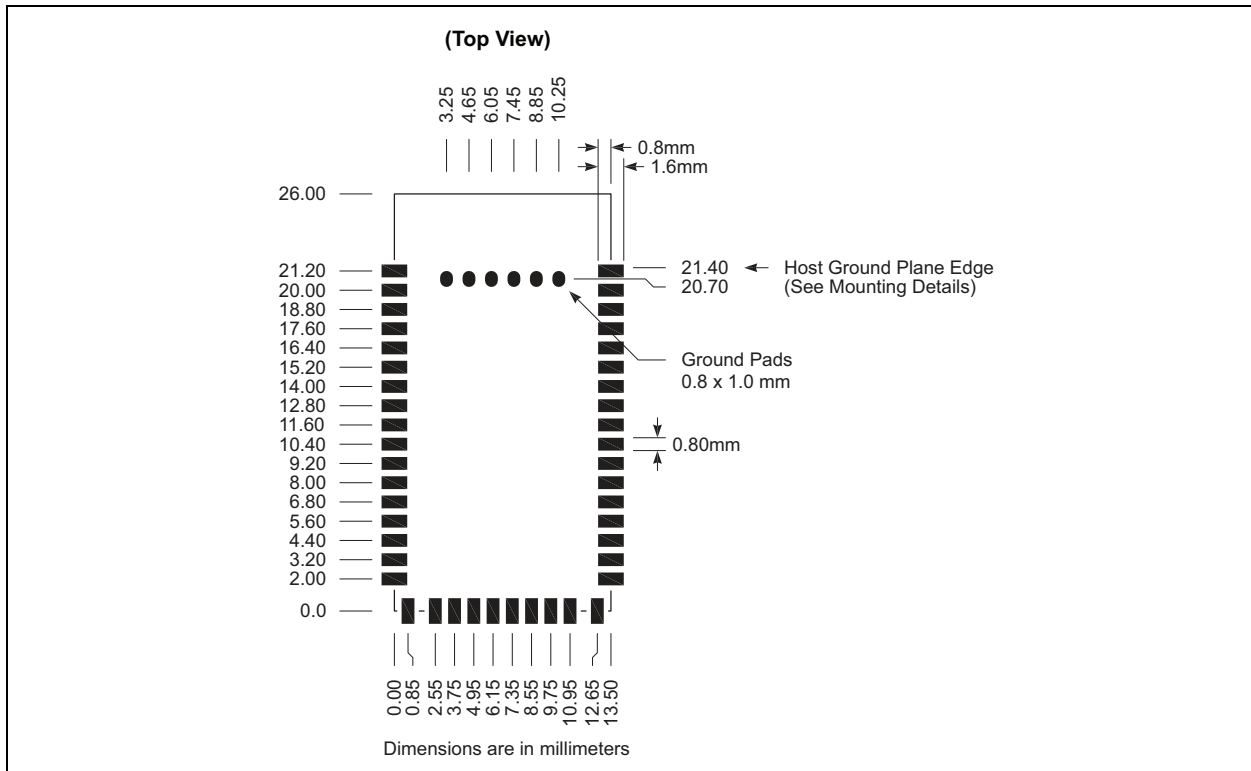

The following figure shows the pinout and the following table describes the module's pins.

# RN52

FIGURE 1-3: PIN DIAGRAM

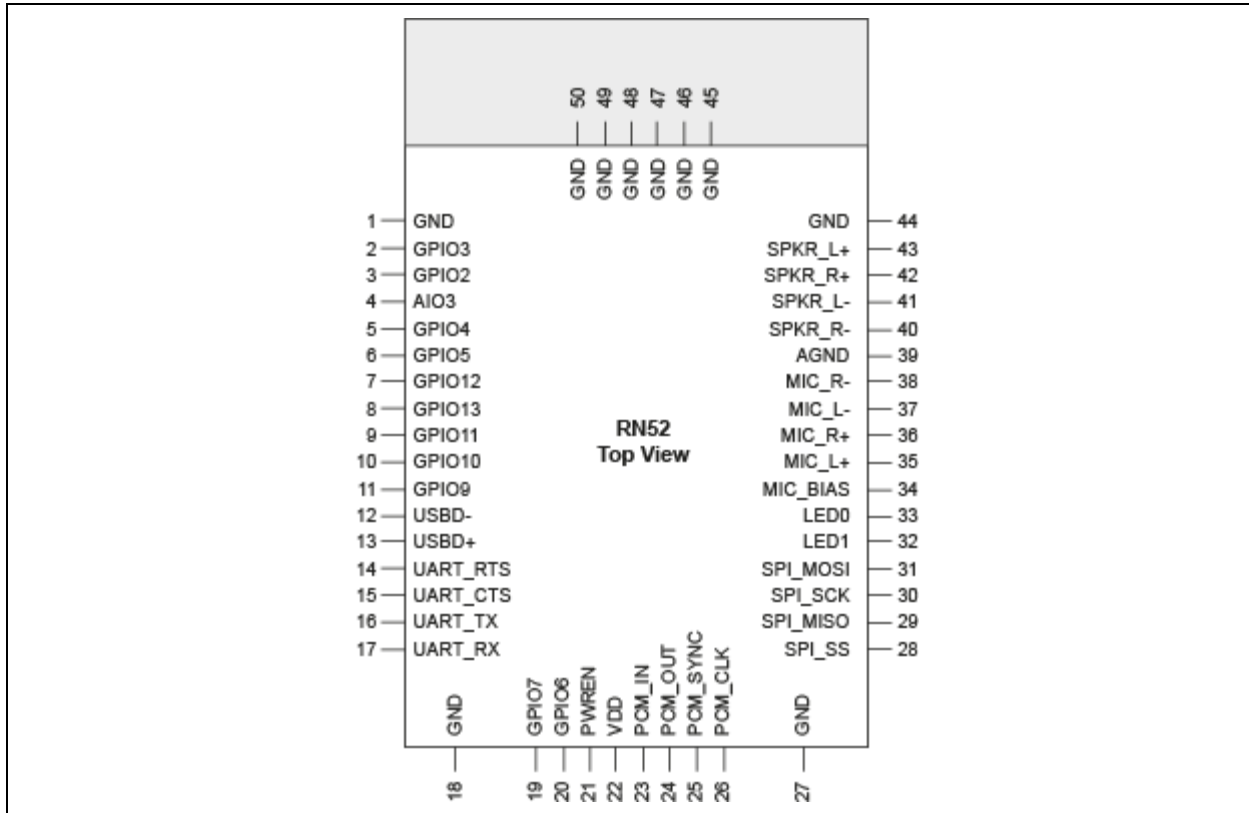

TABLE 1-4: PIN DESCRIPTION<sup>(1)</sup> (SHEET 1 OF 3)

Pin	Symbol	I/O Type	Description	Direction	Default
1	GND	Ground.	Ground.		
2	GPIO3	Digital	Driving this pin high during bootup will put the module in Device Firmware Update (DFU) mode. The device will enter DFU mode in 3 seconds. The pin should only be asserted high before the device enters DFU mode and not after. (USB device powers VBUS. PIO3 requires 47K to ground and 22K to USB VBUS if USB VBUS is supplying power to the main board.) During runtime, if the pin is driven high, the device will reset and reboot. Note: Device will reset within 500 ms after the IO is driven high. A reset pulse of 100 ms is recommended. If IO continues to be driven high after reset, the device will naturally enter DFU mode. The device will enter DFU mode in 3 seconds.	Input	Low
3	GPIO2	Digital	Reserved, event indicator pin. A microcontroller can enter Command mode and poll the state register using the Q action command	Output	High
4	AIO0	Bidirectional	Analog programmable input/output line	I/O	—

**TABLE 1-4: PIN DESCRIPTION<sup>(1)</sup> (SHEET 2 OF 3)**

Pin	Symbol	I/O Type	Description	Direction	Default
5	GPIO4	Digital	Factory Reset mode. To reset the module to the factory defaults, GPIO4 should be high on power-up and then toggle low, high, low, high with a 1 second wait between the transitions. During runtime, the module will enter voice command mode if this pin is driven low. Reserved. Not available for reconfiguring as a general purpose IO pin.	Input	Low
6	GPIO5	Bidirectional with programmable strength internal pull-up/down	Programmable I/O	I/O	High
7	GPIO12	Bidirectional with programmable strength internal pull-up/down	Programmable I/O	I/O	High
8	GPIO13	Bidirectional with programmable strength internal pull-up/down	Programmable I/O	I/O	High
9	GPIO11	Bidirectional with programmable strength internal pull-up/down	Programmable I/O	I/O	High
10	GPIO10	Bidirectional with programmable strength internal pull-up/down	Programmable I/O	I/O	High
11	GPIO9	Digital	When you drive this signal low, the module's UART goes into Command mode. If this signal is asserted high, the UART is in Data mode. Reserved	Input	High
12	USBD-	Bidirectional	USB data minus	I/O	—
13	USBD+	Bidirectional	USB data plus with selectable internal 1.5 KOhm pull-up resistor	I/O	—
14	UART_RTS	CMOS output, tri-state, with weak internal pull-up	UART request to send active low	Output	—
15	UART_CTS	CMOS input with weak internal pull-down	UART clear to send active low	Input	—
16	UART_TX	CMOS output, tri-state, with weak internal pull-up	UART data output	Output	—
17	UART_RX	CMOS input with weak internal pull-down	UART data input	Input	—
18	GND	Ground	Ground	—	—
19	GPIO7	Bidirectional with programmable strength internal pull-up/down	Driving this pin low sets the UART baud rate to 9,600. By default, the pin is high with a baud rate of 115,200	I/O	High
20	GPIO6	Bidirectional with programmable strength internal pull-up/down	Programmable I/O	I/O	High
21	PWREN	Analog	Pull high to power up RN52	Input	Low
22	VDD	3.3-V power input	3.3V power input	—	—

**TABLE 1-4: PIN DESCRIPTION<sup>(1)</sup> (SHEET 3 OF 3)**

Pin	Symbol	I/O Type	Description	Direction	Default
23	PCM_IN	CMOS input, with weak internal pull down	Synchronous data input, configurable for SPDIF_IN or SD_IN (I <sup>2</sup> S)	Input	—
24	PCM_OUT	CMOS output, with weak internal pull down	Synchronous data output, configurable for SPDIF_OUT or SD_OUT (I <sup>2</sup> S)	Output	—
25	PCM_SYNC	Bidirectional with weak internal pull down	Synchronous data sync; WS (I <sup>2</sup> S)	Output	—
26	PCM_CLK	CMOS input, with weak internal pull down	Synchronous data clock; SCK (I <sup>2</sup> S)	Output	—
27	GND	Ground	Ground	—	—
28	SPI_SS	CMOS input with weak internal pull-up	Chip select for Synchronous Serial Interface active low	Input	—
29	SPI_MISO	CMOS output, tri-state, with weak internal pull-down	Serial Peripheral Interface (SPI) output	Output	—
30	SPI_CLK	Input with weak internal pull-down	SPI clock	Input	—
31	SPI_MOSI	CMOS input, with weak internal pull-down	SPI input	Input	—
32	LED1	Open drain output	Drives an LED. For the RN-52-EK Board, this signal drives the red LED	Output	—
33	LED0	Open drain output	Drives an LED. For the RN-52-EK Board, this signal drives the blue LED	Output	—
34	MIC_BIAS	Analog	Microphone bias	Output	—
35	MIC_L+	Analog	Microphone input positive, left	Input	—
36	MIC_R+	Analog	Microphone input positive, right	Input	—
37	MIC_L-	Analog	Microphone input negative, left	Input	—
38	MIC_R-	Analog	Microphone input negative, right	Input	—
39	AGND	Analog	Ground connection for audio	—	—
40	SPK_R-	Analog	Speaker output negative (right side)	Output	—
41	SPK_L-	Analog	Speaker output negative (left side)	Output	—
42	SPK_R+	Analog	Speaker output positive (right side)	Output	—
43	SPK_L+	Analog	Speaker output positive (left side)	Output	—
44	GND	Ground	Ground	—	—
45	GND	Ground	RF ground	—	—
46	GND	Ground	RF ground	—	—
47	GND	Ground	RF ground	—	—
48	GND	Ground	RF ground	—	—
49	GND	Ground	RF ground	—	—
50	GND	Ground	RF ground	—	—

**Note 1:** All GPIO pins default to input with weak pull-down.

- 2:** Refer to the “Bluetooth Audio Module Command Reference User’s Guide” (DS50002154) and the “RN52SRC Bluetooth Audio Module Command Reference User’s Guide” (DS50002343) for more information about the behavior of the pin and optional features that can be enabled.

## 1.1 Audio Interface Circuit Description

The RN52 audio interface circuit consists of:

- Analog audio interface with differential audio inputs and outputs
- Digital audio interface with configurable S/PDIF and I<sup>2</sup>S interface (A2DP audio output only)

The audio input circuitry has a dual audio input that can be configured as single-ended or fully differential and programmed for microphone or line input. It has an analog and digital programmable gain stage so that it can be optimized for different microphones. See [Figure 1-5](#).

### 1.1.1 DIGITAL AUDIO INTERFACE

The stereo audio CODEC interface has a digital audio interface. It supports the I<sup>2</sup>S and S/PDIF interfaces. The RN52 I<sup>2</sup>S interface is the I<sup>2</sup>S Host and provides the bit clock and phase sync clock. The I<sup>2</sup>S or S/PDIF interface can be configured through command console. The typical application interface can be seen in the following figure.

The audio resolution supported is 24-bit and the max channel size is 32-bit. The supported sample rates are 8KHz, 32KHz, 44.1KHz and 48KHz. The audio resolution and the sample rate can be configured using the UART console command. Refer the RN52 command specification for more information.

**FIGURE 1-4: I<sup>2</sup>S AND SPDIF CONNECTIONS**

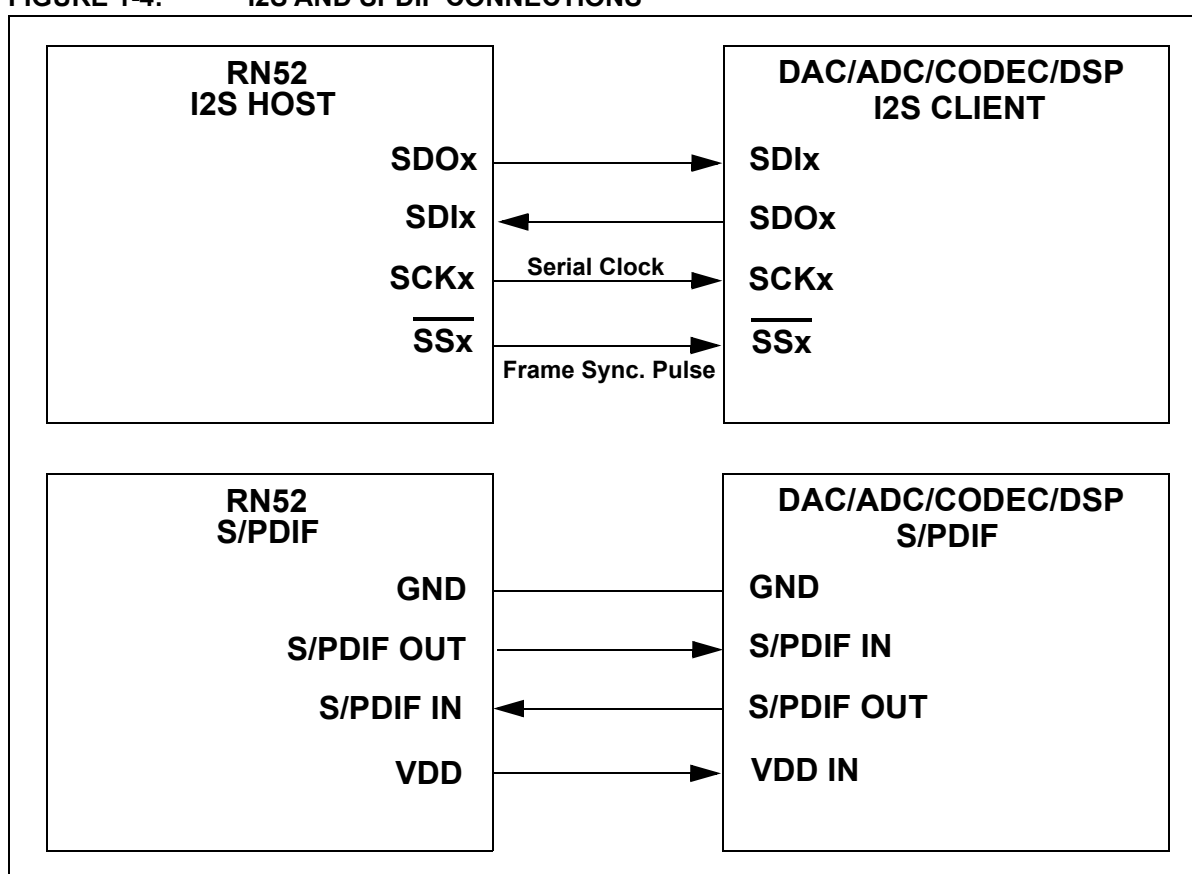

### 1.1.2 ANALOG AUDIO INTERFACE

The audio input circuitry has a dual audio input that can be configured as single-ended or fully differential and programmed for microphone or line input. It has an analog and digital programmable gain stage so that it can be optimized for different microphones. The microphone inputs MIC\_L+, MIC\_L-, MIC\_R+ and MIC\_R- are shown in [Figure 1-6](#).

The audio output circuitry consists of a differential speaker output preceded by a gain stage and a class AB amplifier. The speaker outputs SPK\_L+, SPK\_L-, SPK\_R+ and SPK\_R- are shown in [Figure 1-6](#).

The fully differential architecture in the analog signal path results in low noise sensitivity and good power supply rejection while effectively doubling the signal amplitude. It operates from a 1.5V single power supply and uses a minimum of external components.

The typical application interface is shown in the following figure.

# RN52

FIGURE 1-5: RN52 AUDIO INTERFACE BLOCK DIAGRAM

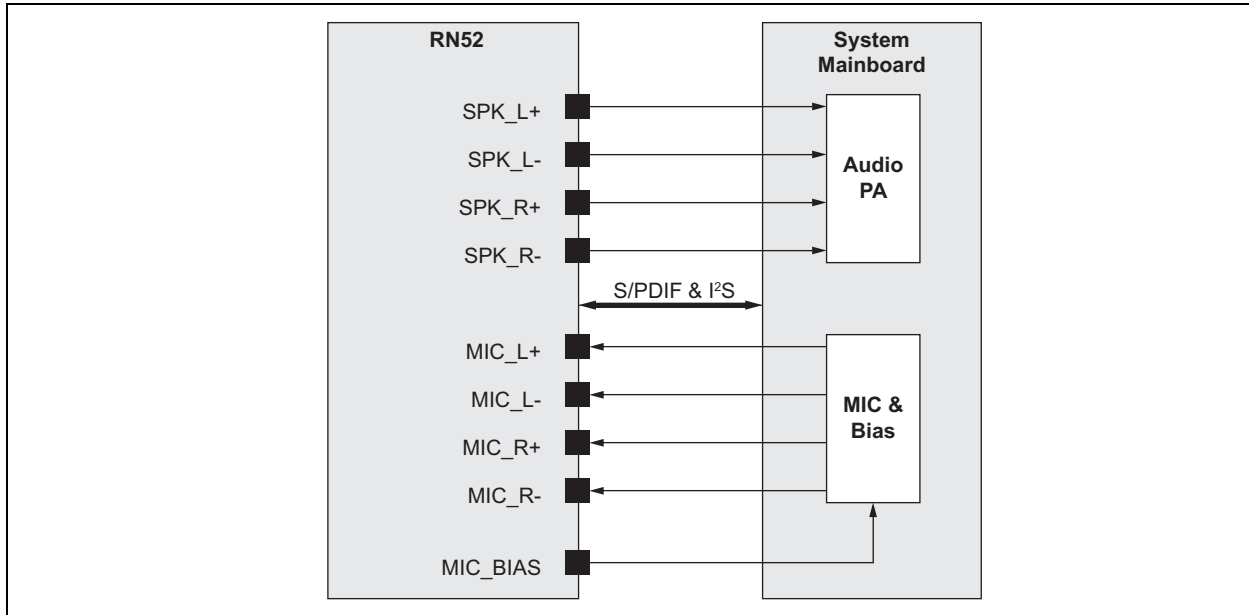
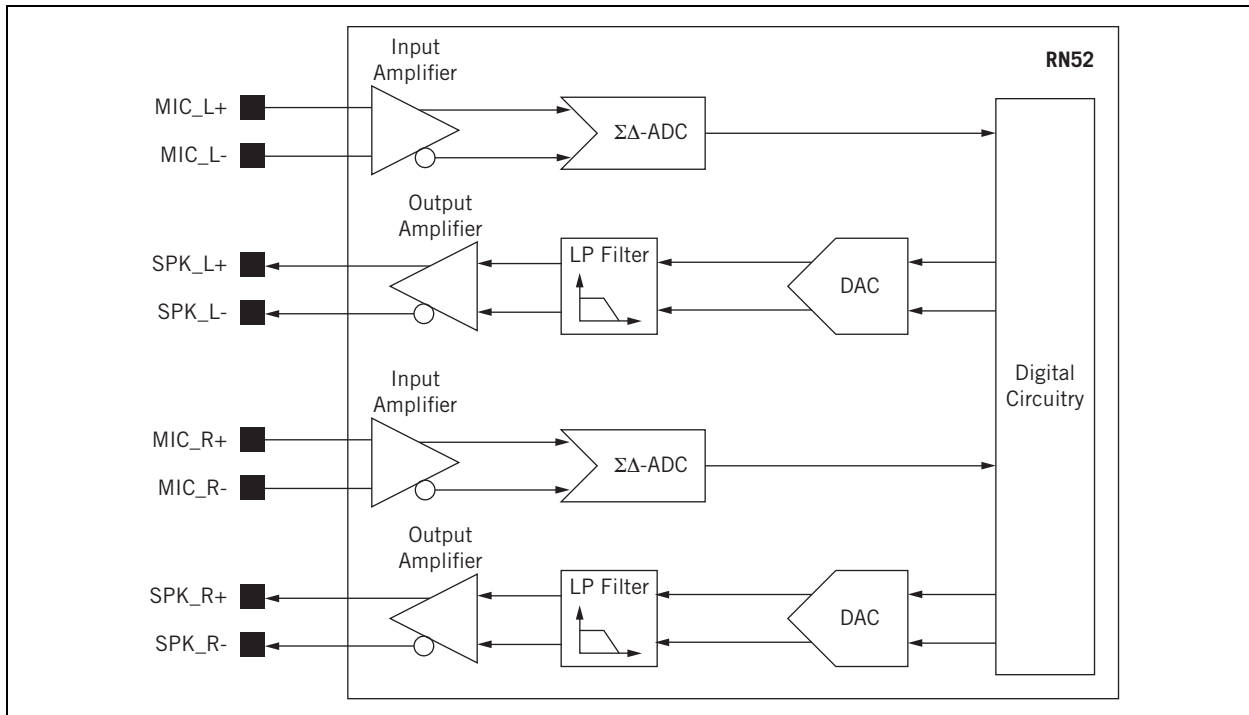

FIGURE 1-6: STEREO CODEC AUDIO INPUT/OUTPUT STAGES





## 1.1.3 ANALOG-TO-DIGITAL CONVERTER (ADC)

The ADC consists of two second-order sigma delta (SD) converters, resulting in two separate channels with identical functionality. Each ADC supports the following sample rates:

- 8 kHz
- 16 kHz
- 32 kHz
- 44.1 kHz
- 48 kHz

The ADC analog amplifier is a two-stage amplifier. The first stage selects the correct gain for either microphone or line input. See the following figure.

**FIGURE 1-7: ADC ANALOG AMPLIFIER BLOCK DIAGRAM**

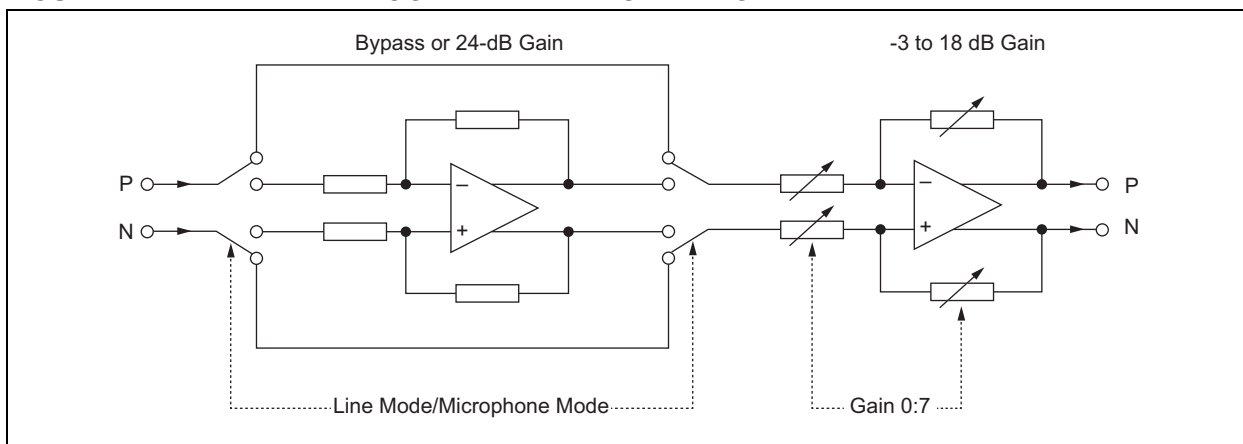

## 1.1.4 DIGITAL-TO-ANALOG CONVERTER (DAC)

The DAC consists of two third-order SD converters, resulting in two separate channels with identical functionality. Each DAC supports the following sample rates:

- 8 kHz
- 16 kHz
- 32 kHz
- 44.1 kHz
- 48 kHz

### 1.1.4.1 Speaker Output

The speaker output is capable of driving a speaker with an impedance of at least 8 ohms directly. The overall gain of the speaker output is approximately -21 dB to 0 dB in 1.5 dB steps.

### 1.1.4.2 Microphone Input

The RN52 audio input is intended for use from 1  $\mu$ A at 94 dB SPL to about 10  $\mu$ A at 94 dB SPL, which requires microphones with sensitivity between -40 and -60 dBV. The RN52 microphone mode input impedance is typically 6 kohm. The line mode input impedance is typically between 6 kohm and 30 kohm. The overall gain of the microphone input is approximately -3 dB to 42 dB in 1.5 dB steps. MIC\_BIAS requires a minimum load to maintain regulation. MIC\_BIAS maintains regulation within 0.199 and 1.229 mA. Therefore, if you use a microphone with specifications below these limits, the microphone output must be pre-loaded with a large value resistor to ground.

# RN52

**TABLE 1-5: DIGITAL TO ANALOG CONVERTER**

Parameter	Conditions	Min	Typ	Max	Unit	
Resolution	—	—	—	16	Bits	
Output Sample Rate, $F_{\text{sample}}$	—	8	—	48	kHz	
Signal to Noise Ratio, SNR	$f_{\text{in}} = 1 \text{ kHz}$ B/W = 20 Hz→20 kHz A-Weighted THD+N < 0.01% 0dBFS signal Load = 100 k $\Omega$	$F_{\text{sample}}$	—	95	—	dB
		8 kHz	—	95	—	dB
		16 kHz	—	95	—	dB
		32 kHz	—	95	—	dB
		44.1 kHz	—	95	—	dB
48 kHz	—	95	—	dB		
Analog Gain	Analog Gain Resolution = 3 dB	0	—	-21	dB	
Output voltage full-scale swing (differential)		—	750	—	mV rms	
Allowed Load	Resistive	16(8)	—	O.C.	$\Omega$	
	Capacitive	—	—	500	pF	
THD + N 100 k $\Omega$ load		—	—	0.01	%	
THD + N 16 k $\Omega$ load		—	—	0.1	%	
SNR (Load = 16 $\Omega$ , 0 dBFS input relative to digital silence)		—	95	—	dB	

**TABLE 1-6: ANALOG TO DIGITAL CONVERTER**

Parameter	Conditions	Min	Typ	Max	Unit	
Resolution	—	—	—	16	Bits	
Input Sample Rate, $F_{\text{sample}}$	—	8	—	44.1	kHz	
Signal to Noise Ratio, SNR	$f_{\text{in}} = 1 \text{ kHz}$ B/W = 20 Hz→20 kHz A-Weighted THD+N < 1% 150 mV <sub>pk-pk</sub> input	$F_{\text{sample}}$	—			
		8 kHz	—	79	—	dB
		16 kHz	—	76	—	dB
		32 kHz	—	75	—	dB
		44.1 kHz	—	75	—	dB
Analog Gain	Analog Gain Resolution = 3 dB	—	—	42	dB	
Input full scale at maximum gain (differential)		—	4	—	mV rms	
Input full scale at minimum gain (differential)		—	800	—	mV rms	
3 dB Bandwidth		—	20	—	kHz	
Microphone mode input impedance		—	6.0	—	k $\Omega$	
THD + N (microphone input) @ 30 mV rms input		—	0.04	—	%	

## 1.2 General Purpose IO (GPIO) Ports

User programmable bidirectional GPIO ports are provided. The GPIO ports can be used as typical digital IO ports. The directionality of the GPIOs can be configured through console commands. The GPIOs can also be read or asserted using the console commands. The digital input and output voltage levels are provided in the following table.

**TABLE 1-7: DIGITAL INPUT AND OUTPUT VOLTAGE LEVELS**

Voltage Information	Min	Typ	Max	Unit
<b>Input Voltage Levels</b>				
V <sub>IL</sub> input logic level low	-0.3	—	0.25 x V <sub>DD</sub>	V
V <sub>IH</sub> input logic level high	0.625 x V <sub>DD</sub>	—	V <sub>DD</sub> + 0.3	V
<b>Output Voltage Levels</b>				
V <sub>OL</sub> output logic level low, I <sub>ol</sub> = 4.0 mA	0	—	0.125	V
V <sub>OH</sub> output logic level high, I <sub>OH</sub> = -4.0 mA	0.75 x V <sub>DD</sub>	—	V <sub>DD</sub>	V

# RN52

## 1.3 Power Consumption

The power consumption of the RN52 for various connection states are provided in the following table.

**TABLE 1-8: POWER CONSUMPTION**

Role	Connection	Audio Packet Type	Description	Current (mA)
—	Stand-by	—	Active connection	0.07
—	Page Scan	—	Interval = 1280 ms	0.5
—	Inquiry and Page Scan	—	Inquiry scan = 1280 ms Page scan = 1280 ms	0.88
RN52	A2DP	ACL	No Traffic	15
RN52	A2DP	ACL	Audio stream RX	21
RN52	A2DP	ACL	Sniff = 40 ms	1.7
RN52	A2DP	ACL	Sniff = 1280 ms	0.26
RN52	HFP	eSCO-EV3	—	26
RN52	HFP	eSCO-EV3	Setting S1	27
RN52	HFP	eSCO-2EV3	Setting S2	28
RN52	HFP	eSCO-2EV3	Setting S3	25
RN52	HFP	eSCO-EV5	—	22
RN52	HFP	SCO-HV1	—	42
RN52	HFP	SCO-HV3	—	28
RN52	HFP	SCO-HV3	Sniff = 30 ms	22
RN52SRC	A2DP	ACL	No traffic	4.4
RN52SRC	A2DP	ACL	Audio stream TX	9.2
RN52SRC	A2DP	ACL	Sniff = 40 ms	1.9
RN52SRC	A2DP	ACL	Sniff = 1280 ms	0.2
RN52SRC	HFP	eSCO-EV3	—	24
RN52SRC	HFP	eSCO-EV3	Setting S1	23
RN52SRC	HFP	eSCO-2EV3	Setting S2	22
RN52SRC	HFP	eSCO-2EV3	Setting S3	17
RN52SRC	HFP	eSCO-EV5	—	17
RN52SRC	HFP	SCO-HV1	—	42
RN52SRC	HFP	SCO-HV3	—	23
RN52SRC	HFP	SCO-HV3	Sniff = 30 ms	22

## 2.0 APPLICATIONS

The following sections provide information on designing with the RN52 module, including restoring factory defaults, using the LED interface, minimizing radio interference, solder reflow profile, typical application, etc.

## 2.1 Minimizing Radio Interference

When laying out the host PCB for the RN52 module, the areas under the antenna and shielding connections should not have surface traces, ground planes or exposed via (see [Figure 2-1](#)). For optimal radio performance, the RN52 module's antenna end should protrude at least 31 mm beyond any metal enclosure. [Figure 2-2](#) shows examples of good, bad and acceptable positioning of the RN52 on the host PCB.

**FIGURE 2-1: MINIMIZING RADIO INTERFERENCE**

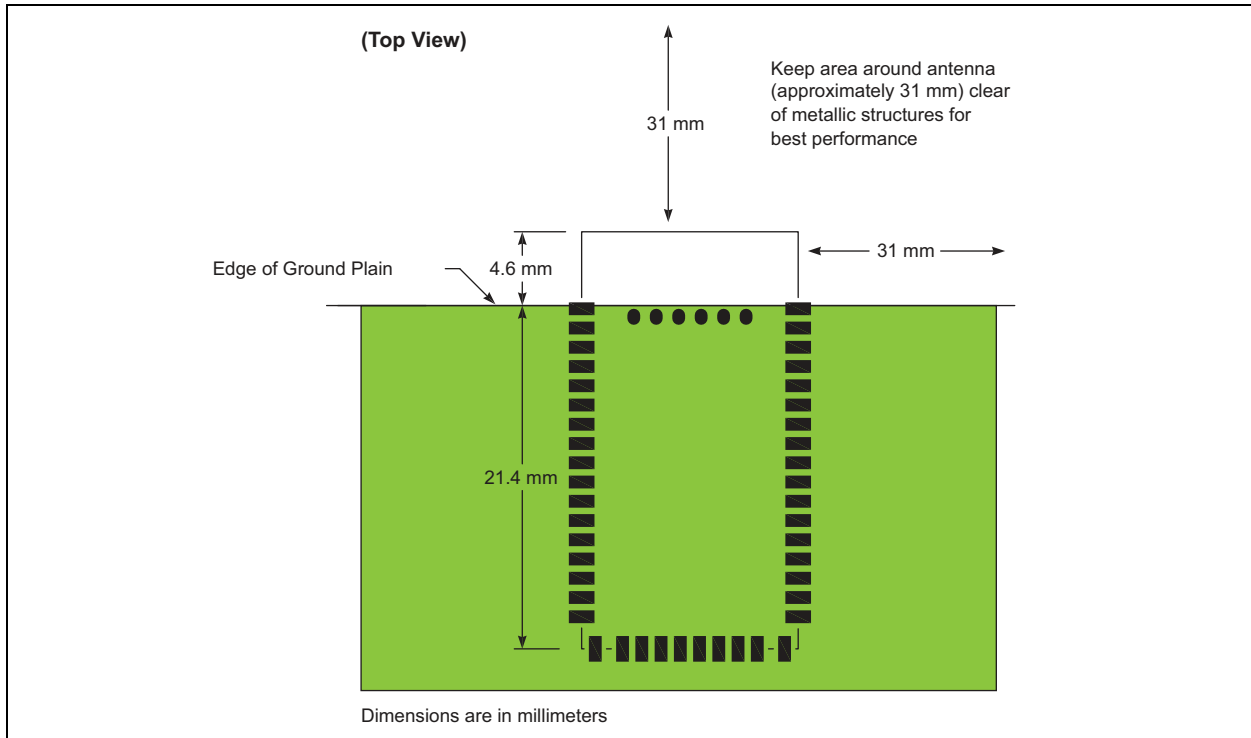

**FIGURE 2-2: PCB EXAMPLE LAYOUT**

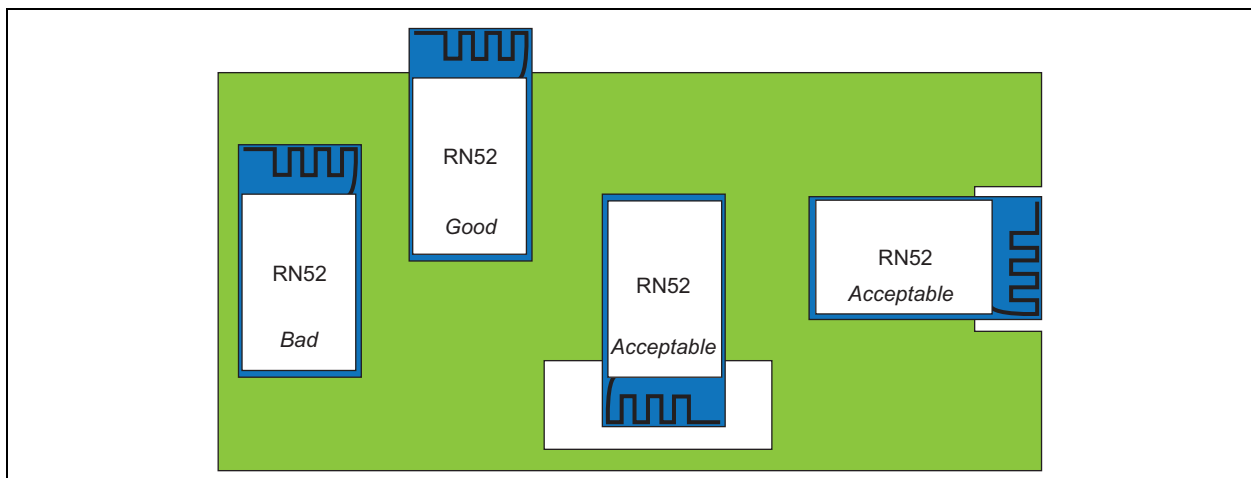

# RN52

## 2.2 LED Interface

The RN52 includes two pads dedicated to driving the LED indicators. The firmware can control both terminals, and the battery charger can set LED0. The terminals are open-drain outputs; therefore, the LED must be connected from a positive supply rail to the pad in series with a current limiting resistor. You should operate the LED pad (LED0 or LED1 pins) with a pad voltage below 0.5V. In this case, the pad can be thought of as a resistor,  $R_{ON}$ . The resistance, together with the external series resistor, sets the current,  $I_{LED}$ , in the LED. The current is also dependent on the external voltage, VDD, as shown in the following figure.

**FIGURE 2-3: LED INTERFACE**

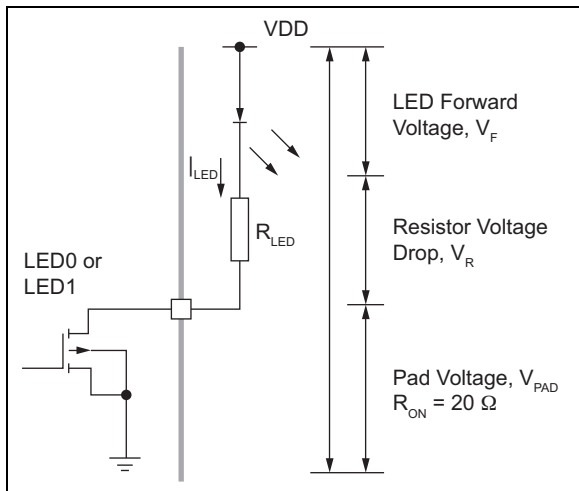

The LEDs can be used to indicate the module's connection status. The following table describes the LED functions.

**TABLE 2-1: STATUS LED FUNCTIONS**

Blue LED	Red LED	Description
Flashing	Flashing	The RN52 module is discoverable.
Off	Flashing	The module is connected.
Flashing	Off	The module is connectable.

## 2.3 Device Firmware Updates

The module has a Device Firmware Update (DFU) mode in which you use the USB interface to update the firmware. Implementing the DFU feature is highly recommended because firmware updates offer new features and enhance the module's functionality. Follow the reference design shown in [Figure 2-7](#) to support this mode.

**Note:** A 47 K $\Omega$  pull-down resistor (R2 in [Figure 2-4](#)) is required on GPIO3 even if you do not use the USB for DFU.

**FIGURE 2-4: USB DFU PORT AND GPIO3 SCHEMATIC**

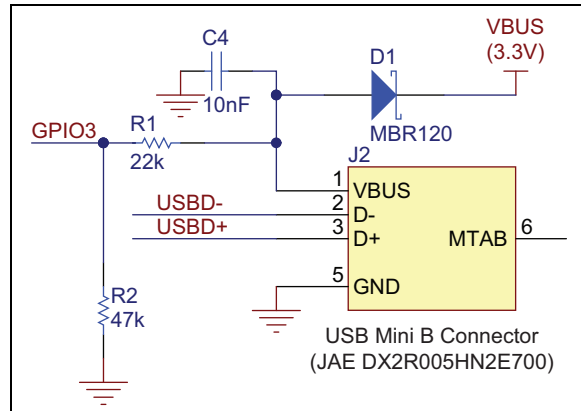

## 2.4 Restore Factory Defaults with GPIO4

The GPIO4 pin should be connected to a switch, jumper or resistor so it can be accessed. This pin is used to reset the module to its factory default settings, which is critical in situations where the module has been misconfigured. To reset the module to the factory defaults, GPIO4 should be high on power-up and then toggle low, high, low, high with a 1 second wait between the transitions.

## 2.5 Power Control and Regulation

The VDD pin controls the power to the RN52 module. The VDD pin should be used to turn the RN52 module on and off, if the hardware power cycle feature is desired.

The PWREN pin provides the power enable functionality. This pin is internally connected as an enable pin to the voltage regulator and can only be used to turn on the voltage regulator after VDD power is provided to the RN52 module. The PWREN pin cannot be used to turn the voltage regulator off.

On later versions of the firmware, the RN52 also provides a module reset GPIO pin, which resets the RN52 module when asserted high, and also provides a console command which can be used to perform a module reset.

## 2.6 Solder Reflow Profile

The lead-free solder reflow temperature and times are:

- **Temperature** – 230° C, 60 seconds maximum, peak 245° C maximum
- **Preheat temperature** – 165° ± 15° C, 90 to 120 seconds
- **Time** – Single pass, one time

To reflow solder the module onto a PCB, use an RoHS-compliant solder paste equivalent to NIHON ALMIT paste or OMNIX OM-310 solder paste from Alpha metals. See the following table.

**Note:** Use no-clean flux and DO NOT water wash.

**TABLE 2-2: PASTE SOLDER RECOMMENDATIONS**

Manufacturer	Part Number	Metal Composition	Liquidus Temperature
Alpha Metals <a href="http://www.alphametals.com">http://www.alphametals.com</a>	OMNIX OM-310	SAC305 (96.5% Sn, 3% Ag, 0.5% Cu)	~220°C
NIHON ALMIT Co. LTD <a href="http://almit.co.jp">http://almit.co.jp</a>	LFM-70W INP	88% Sn, 3.5% Ag, 0.5% Bi, 8% In	~215°C

The following figures show the solder reflow temperature profiles.

**FIGURE 2-5: SOLDER REFLOW TEMPERATURE PROFILE**

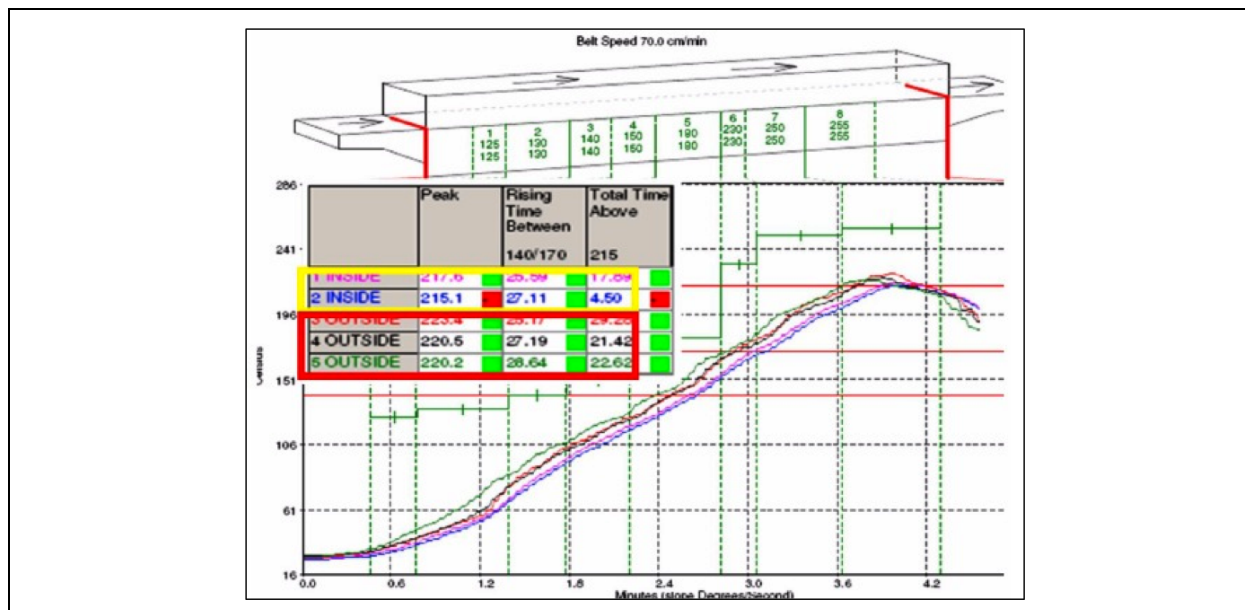
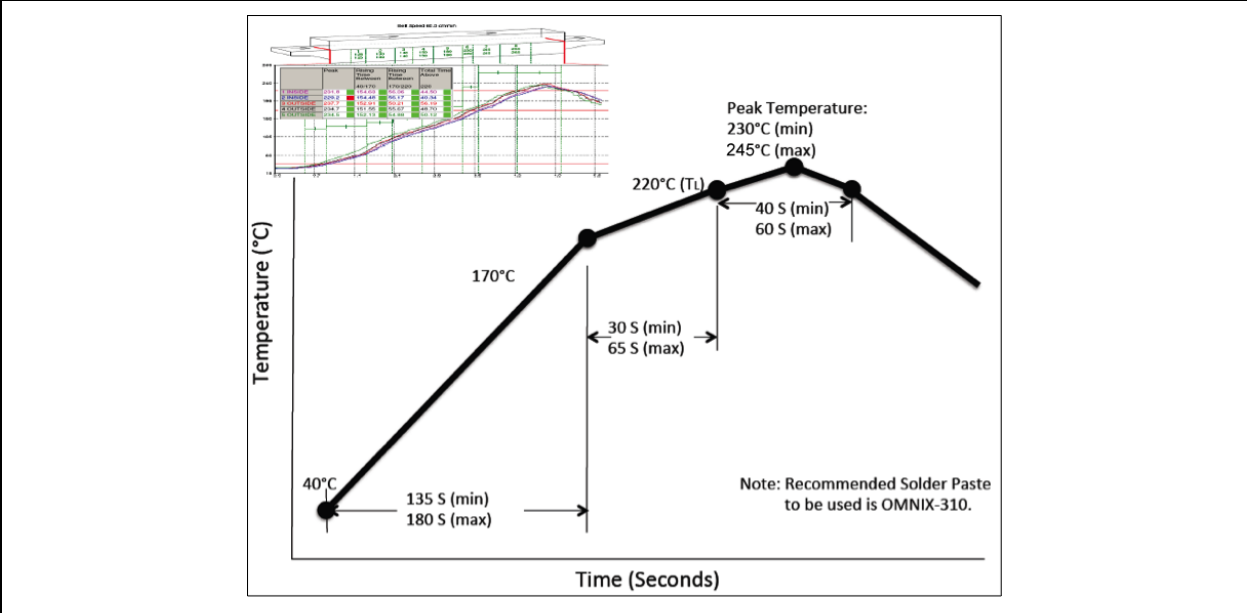

FIGURE 2-6: SOLDER REFLOW CURVE





2.7 Typical Application Schematic

The following figure shows a typical application circuit with LDO, stereo audio/microphone PA, USB/UART, AVRCP switches and LED0/LED1.

FIGURE 2-7: TYPICAL APPLICATION CIRCUIT FOR A2DP AUDIO STREAMING AND AVRCP REMOTE CONTROL

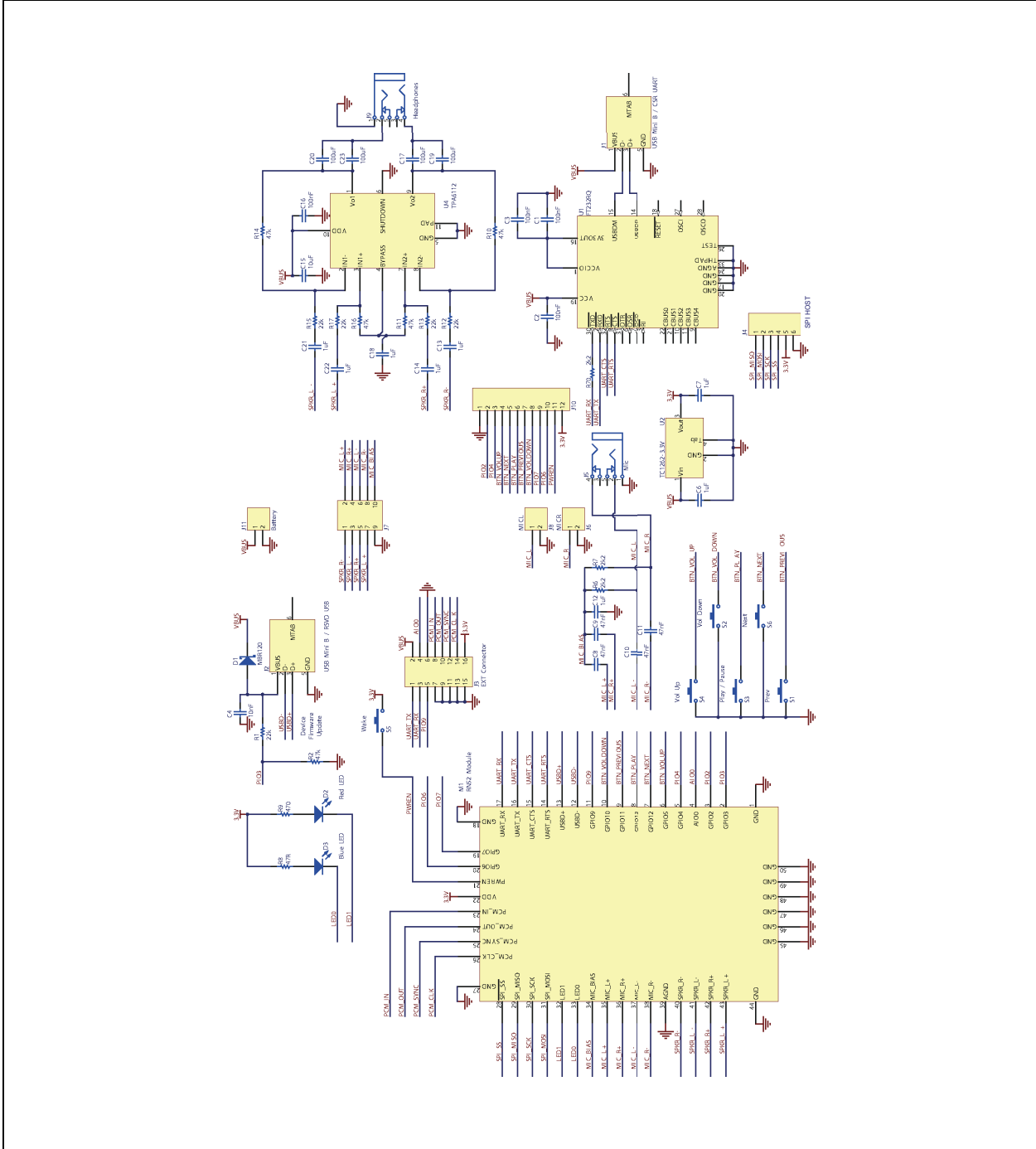

## 3.0 BLUETOOTH SIG CERTIFICATION

The RN52 Bluetooth Audio Module has been certified by Bluetooth SIG and the Qualified Design ID is 58578 and the Declaration ID is D023391. The Qualified Design Listing certificate can be accessed on [www.microchip.com/rn52](http://www.microchip.com/rn52) or at the Bluetooth SIG listings website.

## 4.0 REGULATORY APPROVAL

This section outlines the regulatory information for the RN52 module for the following countries:

- United States
- Canada
- Europe
- Australia
- New Zealand

### 4.1 United States

The RN52 module has received Federal Communications Commission (FCC) CFR47 Telecommunications, Part 15 Subpart C "Intentional Radiators" modular approval in accordance with Part 15.212 Modular Transmitter approval. Modular approval allows the end user to integrate the RN52 module into a finished product without obtaining subsequent and separate FCC approvals for intentional radiation, provided no changes or modifications are made to the module circuitry. Changes or modifications could void the user's authority to operate the equipment. The end user must comply with all of the instructions provided by the Grantee, which indicate installation and/or operating conditions necessary for compliance.

The finished product is required to comply with all applicable FCC equipment authorizations regulations, requirements and equipment functions not associated with the transmitter module portion. For example, compliance must be demonstrated to regulations for other transmitter components within the host product; to requirements for unintentional radiators (Part 15 Subpart B "Unintentional Radiators"), such as digital devices, computer peripherals, radio receivers, etc.; and to additional authorization requirements for the non-transmitter functions on the transmitter module (i.e., Verification, or Declaration of Conformity) (e.g., transmitter modules may also contain digital logic functions) as appropriate.

#### 4.1.1 LABELING AND USER INFORMATION REQUIREMENTS

The RN52 module has been labeled with its own FCC ID number, and if the FCC ID is not visible when the module is installed inside another device, then the outside of the finished product into which the module is

installed must also display a label referring to the enclosed module. This exterior label can use wording as follows:

Contains Transmitter Module FCC ID: T9J-RN52

or

Contains FCC ID: T9J-RN52

This device complies with Part 15 of the FCC Rules. Operation is subject to the following two conditions: (1) this device may not cause harmful interference, and (2) this device must accept any interference received, including interference that may cause undesired operation

A user's manual for the product should include the following statement:

This equipment has been tested and found to comply with the limits for a Class B digital device, pursuant to part 15 of the FCC Rules. These limits are designed to provide reasonable protection against harmful interference in a residential installation. This equipment generates, uses and can radiate radio frequency energy, and if not installed and used in accordance with the instructions, may cause harmful interference to radio communications. However, there is no guarantee that interference will not occur in a particular installation. If this equipment does cause harmful interference to radio or television reception, which can be determined by turning the equipment off and on, the user is encouraged to try to correct the interference by one or more of the following measures:

- Reorient or relocate the receiving antenna.
- Increase the separation between the equipment and receiver.
- Connect the equipment into an outlet on a circuit different from that to which the receiver is connected.
- Consult the dealer or an experienced radio/TV technician for help.

Additional information on labeling and user information requirements for Part 15 devices can be found in KDB Publication 784748 available at the FCC Office of Engineering and Technology (OET) Laboratory Division Knowledge Database (KDB) <http://apps.fcc.gov/oetcf/kdb/index.cfm>.

#### 4.1.2 RF EXPOSURE

All transmitters regulated by FCC must comply with RF exposure requirements. OET Bulletin 65, Evaluating Compliance with FCC Guidelines for Human Exposure to Radio Frequency Electromagnetic Fields, provides assistance in determining whether proposed or existing transmitting facilities, operations or devices comply with limits for human exposure to Radio Frequency

(RF) fields adopted by the Federal Communications Commission (FCC). The bulletin offers guidelines and suggestions for evaluating compliance.

If appropriate, compliance with exposure guidelines for mobile and unlicensed devices can be accomplished by the use of warning labels and by providing users with information concerning minimum separation distances from transmitting structures and proper installation of antennas.

The following statement must be included as a CAUTION statement in manuals and OEM products to alert users of FCC RF exposure compliance:

To satisfy FCC RF Exposure requirements for mobile and base station transmission devices, a separation distance of 20 cm or more should be maintained between the antenna of this device and persons during operation. To ensure compliance, operation at closer than this distance is not recommended.

The antenna(s) used for this transmitter must not be co-located or operating in conjunction with any other antenna or transmitter.

If the RN52 module is used in a portable application (i.e., the antenna is less than 20 cm from persons during operation), the integrator is responsible for performing Specific Absorption Rate (SAR) testing in accordance with FCC rules 2.1091.

#### 4.1.3 APPROVED ANTENNAS

To maintain modular approval in the United States, only the antenna types that have been tested shall be used. It is permissible to use different antenna, provided the same antenna type, antenna gain (equal to or less than), with similar in-band and out-of band characteristics (refer to specification sheet for cutoff frequencies).

#### 4.1.4 HELPFUL WEB SITES

Federal Communications Commission (FCC):  
<http://www.fcc.gov>

FCC Office of Engineering and Technology (OET) Laboratory Division Knowledge Database (KDB):  
<http://apps.fcc.gov/oetcf/kdb/index.cfm>

## 4.2 Canada

The RN52 module has been certified for use in Innovation, Science and Economic Development Canada (ISED, formerly Industry Canada) Radio Standards Specification (RSS) RSS-210 and RSSGen. Modular approval permits the installation of a module in a host device without the need to recertify the device.

#### 4.2.1 LABELING AND USER INFORMATION REQUIREMENTS

Labeling Requirements for the Host Device (from RSP-100, Issue 12, Section 5): The host device shall be properly labeled to identify the module within the host device.

The Industry Canada certification label of a module shall be clearly visible at all times when installed in the host device, otherwise the host device must be labeled to display the Industry Canada certification number of the module, preceded by the words "Contains transmitter module", or the word "Contains", or similar wording expressing the same meaning, as follows:

Contains transmitter module IC: 6514A-RN52

User Manual Notice for License-Exempt Radio Apparatus (from Section 8.4 RSS-Gen, Issue 5, March 2019): User manuals for license-exempt radio apparatus shall contain the following or equivalent notice in a conspicuous location in the user manual or alternatively on the device or both:

This device contains license-exempt transmitter(s)/receiver(s) that comply with Innovation, Science and Economic Development Canada's license-exempt RSS(s). Operation is subject to the following two conditions:

1. This device may not cause interference;
2. This device must accept any interference, including interference that may cause undesired operation of the device.

L'émetteur/récepteur exempt de licence contenu dans le présent appareil est conforme aux CNR d'Innovation, Sciences et Développement économique Canada applicables aux appareils radio exempts de licence. L'exploitation est autorisée aux deux conditions suivantes:

1. L'appareil ne doit pas produire de brouillage;
2. L'appareil doit accepter tout brouillage radioélectrique subi, même si le brouillage est susceptible d'en compromettre le fonctionnement.

# RN52

Transmitter Antenna (From Section 6.8 RSS-GEN, Issue 5, March 2019): User manuals, for transmitters shall display the following notice in a conspicuous location:

This radio transmitter [IC: 6514A-RN52] has been approved by Innovation, Science and Economic Development Canada to operate with the antenna types listed below, with the maximum permissible gain indicated. Antenna types not included in this list that have a gain greater than the maximum gain indicated for any type listed are strictly prohibited for use with this device.

Le présent émetteur radio [IC: 6514A-RN52] a été approuvé par Innovation, Sciences et Développement économique Canada pour fonctionner avec les types d'antenne énumérés ci-dessous et ayant un gain admissible maximal. Les types d'antenne non inclus dans cette liste, et dont le gain est supérieur au gain maximal indiqué pour tout type figurant sur la liste, sont strictement interdits pour l'exploitation de l'émetteur.

Immediately following the above notice, the manufacturer shall provide a list of all antenna types approved for use with the transmitter, indicating the maximum permissible antenna gain (in dBi) and required impedance for each.

## 4.2.2 HELPFUL WEB SITES

Industry Canada: <http://www.ic.gc.ca/>

## 4.3 Europe

The RN52 module is Radio Equipment Directive (RED) assessed, CE marked, and have been manufactured and tested with the intention of being integrated into a final product.

The RN52 module has been tested to RED 2014/53/EU Essential Requirements mentioned in the following European Compliance table.

**TABLE 4-1: EUROPEAN COMPLIANCE**

Certification	Standards	Article
Safety	EN 62368	3.1a
Health	EN 62311	
Electro Magnetic Compatibility (EMC)	EN 301 489-1	3.1b
	EN 301 489-17	
Radio	EN300 328	3.2

The ETSI provides guidance on modular devices in “*Guide to the application of harmonised standards covering Article 3.1b and Article 3.2 of the Directive 2014/53/EU RED to multi-radio and combined radio and non-*

*radio equipment*” document available at [http://www.etsi.org/deliver/etsi\\_eg/203300\\_203399/203367/01.01.01\\_60/eg\\_203367v010101p.pdf](http://www.etsi.org/deliver/etsi_eg/203300_203399/203367/01.01.01_60/eg_203367v010101p.pdf).

**Note:** To maintain conformance to the standards listed in the preceding European Compliance table, the module shall be installed in accordance with the installation instructions in this data sheet and shall not be modified. When integrating a radio module into a completed product, the integrator becomes the manufacturer of the final product and is therefore responsible for demonstrating compliance of the final product with the essential requirements against the RED.

## 4.3.1 LABELING AND USER INFORMATION REQUIREMENTS

The label on the final product which contains the RN52 module must follow CE marking requirements.

## 4.3.2 CONFORMITY ASSESSMENT

From ETSI Guidance Note EG 203367, section 6.1 Non-radio products are combined with a radio product:

If the manufacturer of the combined equipment installs the radio product in a host non-radio product in equivalent assessment conditions (i.e. host equivalent to the one used for the assessment of the radio product) and according to the installation instructions for the radio product, then no additional assessment of the combined equipment against article 3.2 of the RED is required.

## 4.3.2.1 SIMPLIFIED EU DECLARATION OF CONFORMITY

Hereby, Microchip Technology Inc. declares that the radio equipment type RN52 is in compliance with Directive 2014/53/EU.

The full text of the EU declaration of conformity for this product is available at

<https://www.microchip.com/wwwproducts/en/RN52>

(available under *Documents > Certifications*).

## 4.3.3 APPROVED ANTENNAS

For RN52, the approval is received using the on-board antenna.

## 4.3.4 HELPFUL WEB SITES

A document that can be used as a starting point in understanding the use of Short Range Devices (SRD) in Europe is the European Radio Communications Committee (ERC) Recommendation 70-03 E, which can be downloaded from the European Radio Communications Committee (ECC) at: <http://www.ecodocdb.dk/>.

Additional helpful web sites are:

- Radio Equipment Directive (2014/53/EU): [https://ec.europa.eu/growth/single-market/european-standards/harmonised-standards/red\\_en](https://ec.europa.eu/growth/single-market/european-standards/harmonised-standards/red_en)
- European Conference of Postal and Telecommunications Administrations (CEPT): <http://www.cept.org>
- European Telecommunications Standards Institute (ETSI): <http://www.etsi.org>
- The Radio Equipment Directive Compliance Association (REDCA): <http://www.redca.eu/>

## 4.4 Australia

The Australia radio regulations do not provide a modular approval policy similar to the United States (FCC) and Canada (ISED). However, RN52 module RF transmitter test reports can be used in part to demonstrate compliance in accordance with ACMA Radio communications “Short Range Devices” Standard 2004 (The Short Range Devices standard calls up the AS/NZS 4268:2008 industry standard). The RN52 module test reports can be used as part of the product certification and compliance folder. For more information on the RF transmitter test reports, contact Microchip Technology Australia sales office.

To meet overall Australian final product compliance, the developer must construct a compliance folder containing all relevant compliance test reports, e.g. RF, EMC, electrical safety and DoC (Declaration of Conformity), etc. It is the responsibility of the integrator to know what is required in the compliance folder for ACMA compliance. All test reports are available on the RN52 product web page at <http://www.microchip.com>. For more information on Australia compliance, refer to the Australian Communications and Media Authority web site: <http://www.acma.gov.au/>.

### 4.4.1 HELPFUL WEB SITES

The Australian Communications and Media Authority: [www.acma.gov.au/](http://www.acma.gov.au/).

## 4.5 New Zealand

The New Zealand radio regulations do not provide a modular approval policy similar to the United States (FCC) and Canada (ISED). However, RN52 module RF transmitter test reports can be used in part to demonstrate compliance against the New Zealand “General User Radio License for Short Range Devices”. New Zealand Radio communications (Radio Standards) Notice 2010 calls up the AS / NZS 4268:2008 industry standard. The RN52 module test reports can be used as part of the product certification and compliance folder. All test reports are available on the RN52 product web page at <http://www.microchip.com>. For more information on the RF transmitter test reports, contact Microchip Technology sales office.

Information on the New Zealand short range devices license can be found in the following web links:

<http://www.rsm.govt.nz/cms/licensees/types-oflicence/general-user-licences/short-range-devices>

and

<http://www.rsm.govt.nz/cms/policy-and-planning/spectrum-policy-overview/legislation/gazette-notices/product-compliance/radiocommunications-radiostandards-notice-2010>.

To meet overall New Zealand final product compliance, the developer must construct a compliance folder containing all relevant compliance test reports e.g. RF, EMC, electrical safety and DoC (Declaration of Conformity) etc. It is the responsibility of the developer to know what is required in the compliance folder for New Zealand Radio communications. For more information on New Zealand compliance, refer to the web site: <http://www.rsm.govt.nz/>.

### 4.5.1 HELPFUL WEB SITES

Radio Spectrum Ministry of Economic Development: <http://www.rsm.govt.nz/>.

## 4.6 UKCA (UK Conformity Assessed)

The RN52 module is a UK conformity assessed radio module that meets all the essential requirements according to CE RED requirements.

### 4.6.1 LABELING REQUIREMENTS FOR MODULE AND USER'S REQUIREMENTS

The label on the final product that contains the RN52 module must follow the UKCA marking requirements.



The UKCA mark above is printed on the module itself or on the packing label.

Additional details for the label requirement are available at:

<https://www.gov.uk/guidance/using-the-ukca-marking#check-whether-you-need-to-use-the-new-ukca-marking>.

### 4.6.2 UKCA DECLARATION OF CONFORMITY

Hereby, Microchip Technology Inc. declares that the radio equipment type RN52 is in compliance with the Radio Equipment Regulations 2017.

The full text of the UKCA declaration of conformity for this product is available (under *Documents > Certifications*) at:

• <https://www.microchip.com/en-us/product/RN52>

### 4.6.3 APPROVED ANTENNAS

The testing of the RN52 module was performed with the on-board antenna.

### 4.6.4 HELPFUL WEB SITES

For more information on the UKCA regulatory approvals, refer to the <https://www.gov.uk/guidance/placing-manufactured-goods-on-the-market-in-great-britain>.

## 5.0 ORDERING INFORMATION

The following table provides ordering information for the RN52 module.

**TABLE 5-1: ORDERING INFORMATION<sup>(1)</sup>**

Part Number	Description
RN52-I/RM	Standard application firmware (A2DP/AVRCP/SPP) (central)

**Note 1:** For other configurations, contact Microchip directly.

Go to <http://www.microchip.com> for current pricing and a list of distributors carrying Microchip products.

# RN52

## 6.0 REVISION HISTORY

### Revision A (September 2015)

- This replaces Roving Networks document “RN52 Bluetooth Audio Module Data Sheet”, version 1.1r 3/20/13

**Note:** *Microchip is aware that some terminologies used in the technical documents and existing software codes of this product are outdated and unsuitable. This document may use these new terminologies, which may or may not reflect on the source codes, software GUIs, and the documents referenced within this document. The following table shows the relevant terminology changes made in this document.*

### Revision B (March 2021)

- Added [Section 4.1.3 “Approved Antennas”](#)
- Updated [Section 4.2.1 “Labeling and User Information Requirements”](#)
- Updated [Section 4.3 “Europe”](#)
- Updated with the new terminologies. For more details, see the below note

**TABLE 6-1: TERMINOLOGY RELATED CHANGES**

Old Terminology	New Terminology	Description
Master	Central	<ul style="list-style-type: none"><li>• <a href="#">Section 1.0 “Device Overview”</a> is updated with the new terminology.</li><li>• <a href="#">Table 5-1</a> is updated with the new terminology.</li></ul>
Slave	Peripheral	<a href="#">Section 1.0 “Device Overview”</a> is updated with the new terminology.
Master	Host	<ul style="list-style-type: none"><li>• <a href="#">Section 1.1.1 “Digital Audio Interface”</a> is updated with the new terminology.</li><li>• <a href="#">Figure 1-4</a> is updated with the new terminology.</li><li>• <a href="#">Figure 2-7</a> is updated with the new terminology.</li></ul>
Slave	Client	<a href="#">Figure 1-4</a> is updated with the new terminology.

### Revision C (July 2022)

This revision includes the following changes:

**TABLE C-1: MAJOR SECTION UPDATES**

Section	Update Description
<a href="#">4.6 “UKCA (UK Conformity Assessed)”</a>	Added UKCA regulatory approval information.



NOTES:



---

---

**Note the following details of the code protection feature on Microchip products:**

- Microchip products meet the specifications contained in their particular Microchip Data Sheet.
- Microchip believes that its family of products is secure when used in the intended manner, within operating specifications, and under normal conditions.
- Microchip values and aggressively protects its intellectual property rights. Attempts to breach the code protection features of Microchip product is strictly prohibited and may violate the Digital Millennium Copyright Act.
- Neither Microchip nor any other semiconductor manufacturer can guarantee the security of its code. Code protection does not mean that we are guaranteeing the product is "unbreakable" Code protection is constantly evolving. Microchip is committed to continuously improving the code protection features of our products.

---

This publication and the information herein may be used only with Microchip products, including to design, test, and integrate Microchip products with your application. Use of this information in any other manner violates these terms. Information regarding device applications is provided only for your convenience and may be superseded by updates. It is your responsibility to ensure that your application meets with your specifications. Contact your local Microchip sales office for additional support or, obtain additional support at <https://www.microchip.com/en-us/support/design-help/client-support-services>.

THIS INFORMATION IS PROVIDED BY MICROCHIP "AS IS". MICROCHIP MAKES NO REPRESENTATIONS OR WARRANTIES OF ANY KIND WHETHER EXPRESS OR IMPLIED, WRITTEN OR ORAL, STATUTORY OR OTHERWISE, RELATED TO THE INFORMATION INCLUDING BUT NOT LIMITED TO ANY IMPLIED WARRANTIES OF NON-INFRINGEMENT, MERCHANTABILITY, AND FITNESS FOR A PARTICULAR PURPOSE, OR WARRANTIES RELATED TO ITS CONDITION, QUALITY, OR PERFORMANCE.

IN NO EVENT WILL MICROCHIP BE LIABLE FOR ANY INDIRECT, SPECIAL, PUNITIVE, INCIDENTAL, OR CONSEQUENTIAL LOSS, DAMAGE, COST, OR EXPENSE OF ANY KIND WHATSOEVER RELATED TO THE INFORMATION OR ITS USE, HOWEVER CAUSED, EVEN IF MICROCHIP HAS BEEN ADVISED OF THE POSSIBILITY OR THE DAMAGES ARE FORESEEABLE. TO THE FULLEST EXTENT ALLOWED BY LAW, MICROCHIP'S TOTAL LIABILITY ON ALL CLAIMS IN ANY WAY RELATED TO THE INFORMATION OR ITS USE WILL NOT EXCEED THE AMOUNT OF FEES, IF ANY, THAT YOU HAVE PAID DIRECTLY TO MICROCHIP FOR THE INFORMATION.

Use of Microchip devices in life support and/or safety applications is entirely at the buyer's risk, and the buyer agrees to defend, indemnify and hold harmless Microchip from any and all damages, claims, suits, or expenses resulting from such use. No licenses are conveyed, implicitly or otherwise, under any Microchip intellectual property rights unless otherwise stated.

For information regarding Microchip's Quality Management Systems, please visit [www.microchip.com/quality](http://www.microchip.com/quality).

**Trademarks**

The Microchip name and logo, the Microchip logo, Adaptec, AVR, AVR logo, AVR Freaks, BesTime, BitCloud, CryptoMemory, CryptoRF, dsPIC, flexPWR, HELDO, IGL00, JukeBlox, KeeLoq, Klear, LANCheck, LinkMD, maXStylus, maXTouch, MediaLB, megaAVR, Microsemi, Microsemi logo, MOST, MOST logo, MPLAB, OptoLyzer, PIC, picoPower, PICSTART, PIC32 logo, PolarFire, Prochip Designer, QTouch, SAM-BA, SenGenuity, SpyNIC, SST, SST Logo, SuperFlash, Symmetricom, SyncServer, Tachyon, TimeSource, tinyAVR, UNI/O, Vectron, and XMEGA are registered trademarks of Microchip Technology Incorporated in the U.S.A. and other countries.

AgileSwitch, APT, ClockWorks, The Embedded Control Solutions Company, EtherSynch, Flashtec, Hyper Speed Control, HyperLight Load, Libero, motorBench, mTouch, Powermite 3, Precision Edge, ProASIC, ProASIC Plus, ProASIC Plus logo, Quiet-Wire, SmartFusion, SyncWorld, Temux, TimeCesium, TimeHub, TimePictra, TimeProvider, TrueTime, and ZL are registered trademarks of Microchip Technology Incorporated in the U.S.A.

Adjacent Key Suppression, AKS, Analog-for-the-Digital Age, Any Capacitor, AnyIn, AnyOut, Augmented Switching, BlueSky, BodyCom, Clockstudio, CodeGuard, CryptoAuthentication, CryptoAutomotive, CryptoCompanion, CryptoController, dsPICDEM, dsPICDEM.net, Dynamic Average Matching, DAM, ECAN, Espresso T1S, EtherGREEN, GridTime, IdealBridge, In-Circuit Serial Programming, ICSP, INICnet, Intelligent Paralleling, IntelliMOS, Inter-Chip Connectivity, JitterBlocker, Knob-on-Display, KoD, maxCrypto, maxView, memBrain, Mindi, MiWi, MPASM, MPF, MPLAB Certified logo, MPLIB, MPLINK, MultiTRAK, NetDetach, Omniscient Code Generation, PICDEM, PICDEM.net, PICkit, PICtail, PowerSmart, PureSilicon, QMatrix, REAL ICE, Ripple Blocker, RTAX, RTG4, SAM-ICE, Serial Quad I/O, simpleMAP, SimpliPHY, SmartBuffer, SmartHLS, SMART-I.S., storClad, SQI, SuperSwitcher, SuperSwitcher II, Switchtec, SynchroPHY, Total Endurance, Trusted Time, TSHARC, USBCheck, VariSense, VectorBlox, VeriPHY, ViewSpan, WiperLock, XpressConnect, and ZENA are trademarks of Microchip Technology Incorporated in the U.S.A. and other countries.

SQTP is a service mark of Microchip Technology Incorporated in the U.S.A.

The Adaptec logo, Frequency on Demand, Silicon Storage Technology, and Symmcom are registered trademarks of Microchip Technology Inc. in other countries.

GestIC is a registered trademark of Microchip Technology Germany II GmbH & Co. KG, a subsidiary of Microchip Technology Inc., in other countries.

All other trademarks mentioned herein are property of their respective companies.

© 2015-2022, Microchip Technology Incorporated and its subsidiaries.

All Rights Reserved.

ISBN: 978-1-6683-0547-8



# MICROCHIP

## Worldwide Sales and Service

### AMERICAS

**Corporate Office**  
2355 West Chandler Blvd.  
Chandler, AZ 85224-6199  
Tel: 480-792-7200  
Fax: 480-792-7277  
Technical Support:  
<http://www.microchip.com/support>  
Web Address:  
[www.microchip.com](http://www.microchip.com)

**Atlanta**  
Duluth, GA  
Tel: 678-957-9614  
Fax: 678-957-1455

**Austin, TX**  
Tel: 512-257-3370

**Boston**  
Westborough, MA  
Tel: 774-760-0087  
Fax: 774-760-0088

**Chicago**  
Itasca, IL  
Tel: 630-285-0071  
Fax: 630-285-0075

**Dallas**  
Addison, TX  
Tel: 972-818-7423  
Fax: 972-818-2924

**Detroit**  
Novi, MI  
Tel: 248-848-4000

**Houston, TX**  
Tel: 281-894-5983

**Indianapolis**  
Noblesville, IN  
Tel: 317-773-8323  
Fax: 317-773-5453  
Tel: 317-536-2380

**Los Angeles**  
Mission Viejo, CA  
Tel: 949-462-9523  
Fax: 949-462-9608  
Tel: 951-273-7800

**Raleigh, NC**  
Tel: 919-844-7510

**New York, NY**  
Tel: 631-435-6000

**San Jose, CA**  
Tel: 408-735-9110  
Tel: 408-436-4270

**Canada - Toronto**  
Tel: 905-695-1980  
Fax: 905-695-2078

### ASIA/PACIFIC

**Australia - Sydney**  
Tel: 61-2-9868-6733

**China - Beijing**  
Tel: 86-10-8569-7000

**China - Chengdu**  
Tel: 86-28-8665-5511

**China - Chongqing**  
Tel: 86-23-8980-9588

**China - Dongguan**  
Tel: 86-769-8702-9880

**China - Guangzhou**  
Tel: 86-20-8755-8029

**China - Hangzhou**  
Tel: 86-571-8792-8115

**China - Hong Kong SAR**  
Tel: 852-2943-5100

**China - Nanjing**  
Tel: 86-25-8473-2460

**China - Qingdao**  
Tel: 86-532-8502-7355

**China - Shanghai**  
Tel: 86-21-3326-8000

**China - Shenyang**  
Tel: 86-24-2334-2829

**China - Shenzhen**  
Tel: 86-755-8864-2200

**China - Suzhou**  
Tel: 86-186-6233-1526

**China - Wuhan**  
Tel: 86-27-5980-5300

**China - Xian**  
Tel: 86-29-8833-7252

**China - Xiamen**  
Tel: 86-592-2388138

**China - Zhuhai**  
Tel: 86-756-3210040

### ASIA/PACIFIC

**India - Bangalore**  
Tel: 91-80-3090-4444

**India - New Delhi**  
Tel: 91-11-4160-8631

**India - Pune**  
Tel: 91-20-4121-0141

**Japan - Osaka**  
Tel: 81-6-6152-7160

**Japan - Tokyo**  
Tel: 81-3-6880-3770

**Korea - Daegu**  
Tel: 82-53-744-4301

**Korea - Seoul**  
Tel: 82-2-554-7200

**Malaysia - Kuala Lumpur**  
Tel: 60-3-7651-7906

**Malaysia - Penang**  
Tel: 60-4-227-8870

**Philippines - Manila**  
Tel: 63-2-634-9065

**Singapore**  
Tel: 65-6334-8870

**Taiwan - Hsin Chu**  
Tel: 886-3-577-8366

**Taiwan - Kaohsiung**  
Tel: 886-7-213-7830

**Taiwan - Taipei**  
Tel: 886-2-2508-8600

**Thailand - Bangkok**  
Tel: 66-2-694-1351

**Vietnam - Ho Chi Minh**  
Tel: 84-28-5448-2100

### EUROPE

**Austria - Wels**  
Tel: 43-7242-2244-39  
Fax: 43-7242-2244-393

**Denmark - Copenhagen**  
Tel: 45-4485-5910  
Fax: 45-4485-2829

**Finland - Espoo**  
Tel: 358-9-4520-820

**France - Paris**  
Tel: 33-1-69-53-63-20  
Fax: 33-1-69-30-90-79

**Germany - Garching**  
Tel: 49-8931-9700

**Germany - Haan**  
Tel: 49-2129-3766400

**Germany - Heilbronn**  
Tel: 49-7131-72400

**Germany - Karlsruhe**  
Tel: 49-721-625370

**Germany - Munich**  
Tel: 49-89-627-144-0  
Fax: 49-89-627-144-44

**Germany - Rosenheim**  
Tel: 49-8031-354-560

**Israel - Ra'anana**  
Tel: 972-9-744-7705

**Italy - Milan**  
Tel: 39-0331-742611  
Fax: 39-0331-466781

**Italy - Padova**  
Tel: 39-049-7625286

**Netherlands - Drunen**  
Tel: 31-416-690399  
Fax: 31-416-690340

**Norway - Trondheim**  
Tel: 47-7288-4388

**Poland - Warsaw**  
Tel: 48-22-3325737

**Romania - Bucharest**  
Tel: 40-21-407-87-50

**Spain - Madrid**  
Tel: 34-91-708-08-90  
Fax: 34-91-708-08-91

**Sweden - Gothenberg**  
Tel: 46-31-704-60-40

**Sweden - Stockholm**  
Tel: 46-8-5090-4654

**UK - Wokingham**  
Tel: 44-118-921-5800  
Fax: 44-118-921-5820