

## H W 5 1 3 Hot-wire type gas sensor

HW513 type alcohol sensor through alcohol absorption on the metal oxide semiconductor generates hot conduction and electronics conduction change principal, the white coil resistor change detecting gas concentration. HW513 consists detecting element and compensation element, both elements are placed in a wheatstone bridge circuit, when the alcohol concentration appears, the detecting element resistor reduces, bridge circuit voltage output changes, the voltage will increase according to the alcohol concentration increase, the compensation element refers to temperature compensation affection.

### Features

- High sensitivity, large output
- Fast primary stability time, quick response
- Remarkable reproducibility and reliability.
- Goode selectivity, avoid smoke ethanol disturb
- Low consumption, miniature design

### Applications

Domestic, Industrial spot alcohol concentration detection. Alcohol tester, detector and breath tester.



### Configuration

### Basical detecting circuit

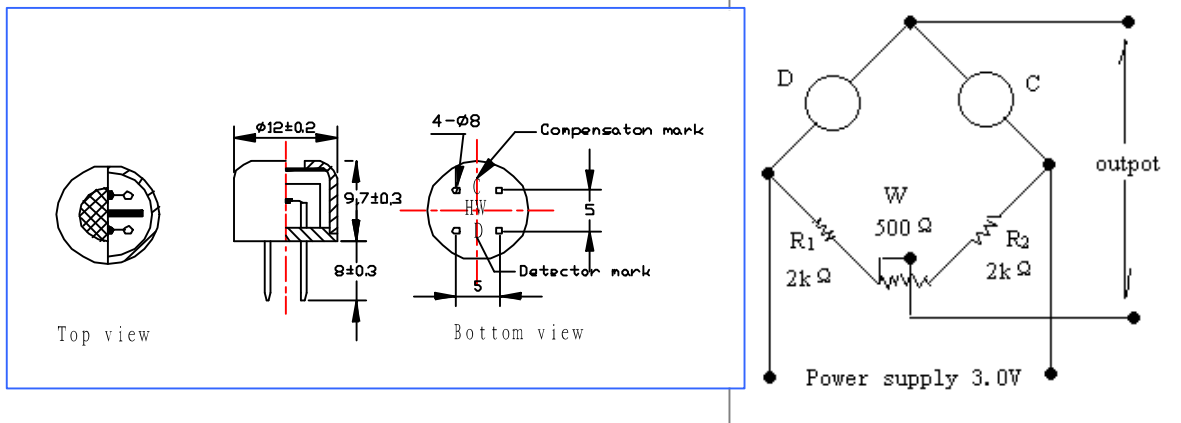

### Specifications

Name	Technical parameter	
Working voltage	$3.0 \pm 0.1$	V
Working current	$@100 \pm 10$	mA
sensitivity   100ppm (Ethanol)	$>100$	mV
Response Time (90%)	Less than 20sec	
Resume time (90%)	Less than 60sec	
Working environment	-20—+60 C Less than 95%RH	
Storage environment	-30—+80 C Less than 95%RH	
Size	$\Phi 12\text{mm} \times 10\text{mm}$	

**Sensitivity ,**

**Response and Resume characteristics**

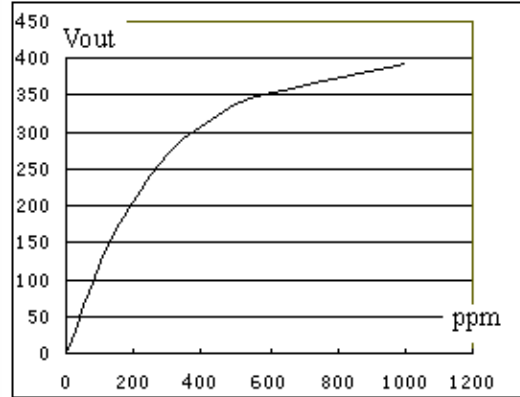
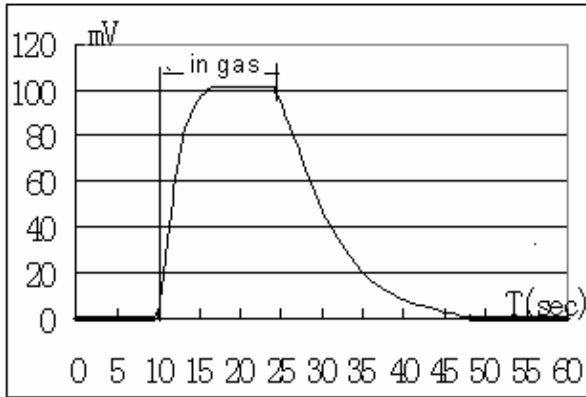

**Long stability**

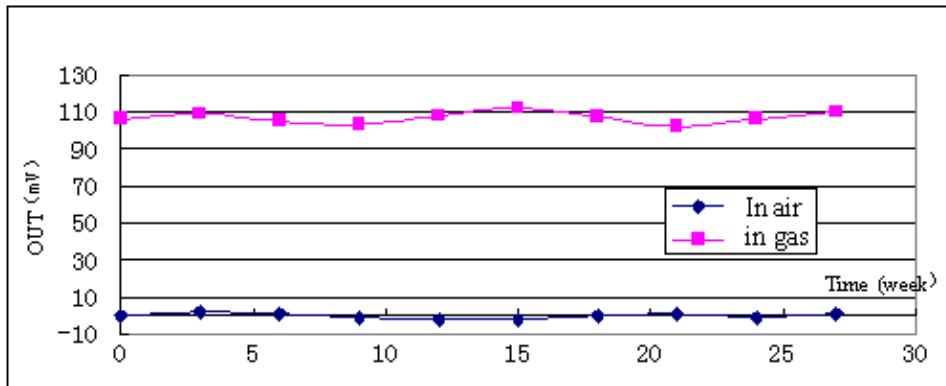

The drift in air per year will be less than 10mV, In 100ppm ethanol less than 10mV.