

HITPOINT

TEL:886-2-2601-3311

FAX:886-2-2601-3898

NO.4 Lane 505, Zhongzheng Rd., Linkou Shiang, Taipei, Taiwan 24445 . R.O.C

Magnetic Buzzer PB-0827MK-36Q

(RoHS)

DATE:2014.12.9

1 . Electrical Characteristics

VER :3

Oscillation Frequency (Hz)	2700
Operating Voltage (Vp-p)	2.5 ~ 4.5
Rated Voltage (Vp-p)	3.6
Current Consumption (mA/max.)	90 at Rated Voltage (Continuous)
Sound Pressure Level (dB/min.)	85 at 10cm at Rated Voltage
Coil Resistance (Ω)	15 ± 3
Operating Temperature ($^{\circ}\text{C}$)	-20 ~ +70
Storage Temperature ($^{\circ}\text{C}$)	-30 ~ +80
Condition by wave ($^{\circ}\text{C}$)	$260 \pm 5^{\circ}\text{C}$ / within 5sec
Condition by hand ($^{\circ}\text{C}$)	$350 \pm 20^{\circ}\text{C}$ / within 5sec

PS : Vp-p=1/2duty , square wave

2 . Typical Frequency Response Curve

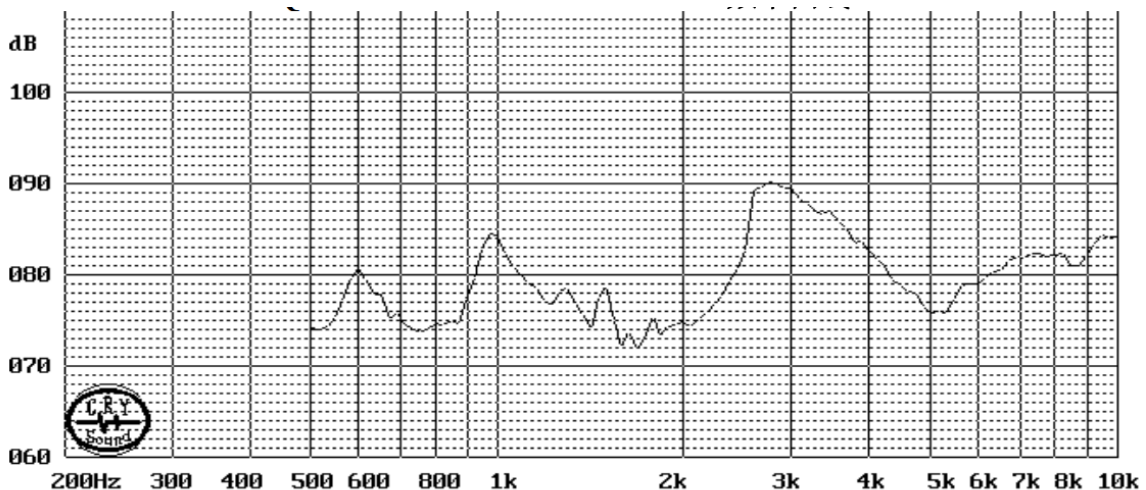

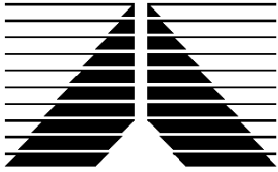

HITPOINT

TEL:886-2-2601-3311

FAX:886-2-2601-3898

NO.4 Lane 505, Zhongzheng Rd., Linkou Shiang, Taipei, Taiwan 24445 . R.O.C

3 . Dimensions and Material

3-1 Shape

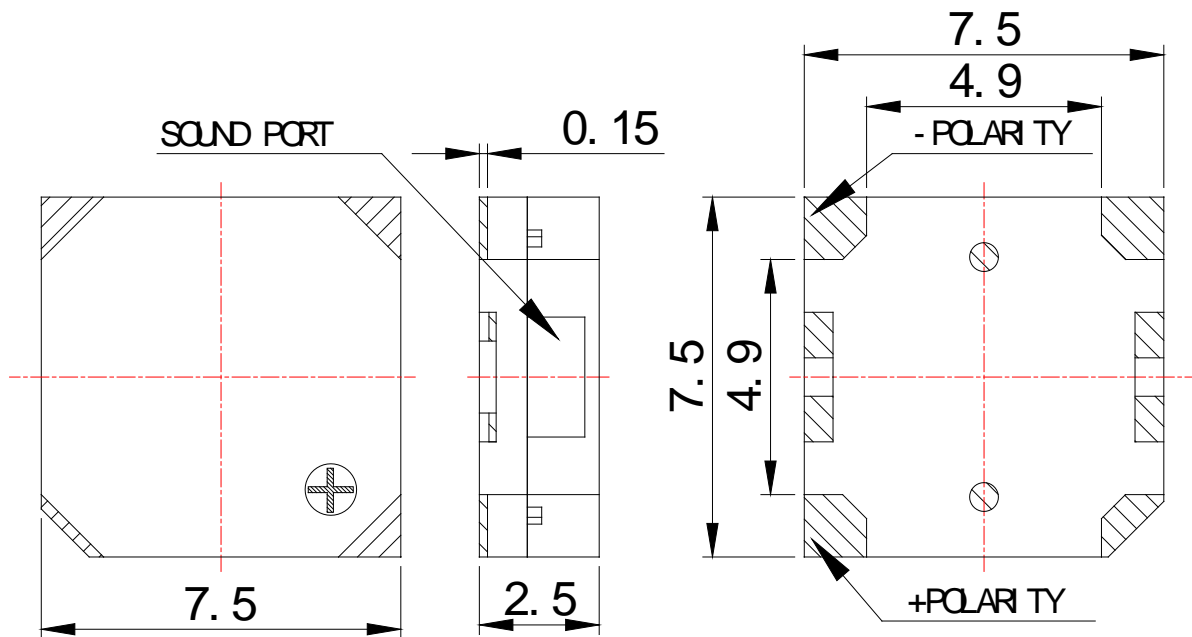

3-2 Material

Housing	LCP(Black)
Leading Pin Plating	Sn
Weight (Gram)	0.4

4 . Recommend Driving Circuit

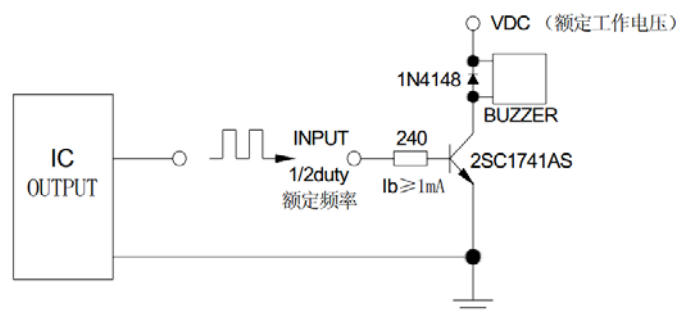

The base current I_b should high enough so that it saturates the collector current of the transistor with the CB load.

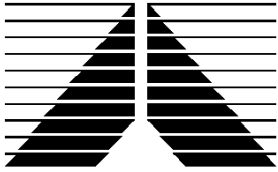

5. TESTING METHOD

• *Standard Measurement conditions*

Temperature:25±2 °C Humidity:45-60%

• *Acoustic Characteristics*

The oscillation frequency, current consumption and sound pressure are measured by the measuring instruments shown below.

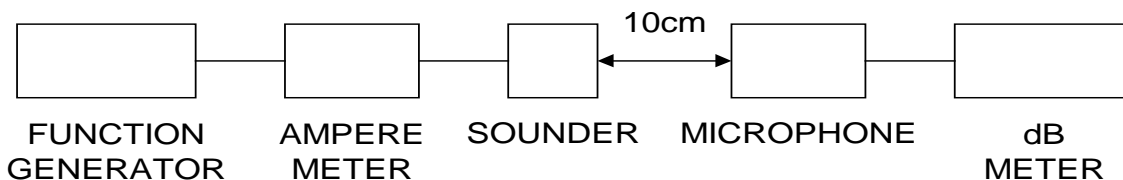

6. RELIABILITY

ITEMS	METHOD OF TEST AND MEASUREMENTS	PERFORMANCE
<i>Coldness withstanding</i>	<i>After 98 hours of being exposed to -30 °C environment, should be returned to normal environment for 2 hours, then re-proceed to test.</i>	<i>No abnormality shall exist</i>
<i>Hotness withstanding</i>	<i>After 98 hours of being exposed to +80 °C environment, should be returned to normal environment for 2 hours, then re-proceed to test.</i>	<i>No abnormality shall exist</i>
<i>Humidity withstanding</i>	<i>After 98 hours of being exposed to 40 °C 95%RH environment in actual operation, should be returned to normal environment for 2 hours, then re-proceed to test.</i>	<i>No abnormality shall exist</i>
<i>Durability</i>	<i>Testing after 98 hours actual continuous operation. (at standard measurement conditions)</i>	<i>No abnormality shall exist</i>
<i>Drop withstanding</i>	<i>A natural drop from 75cm high down to the ground.</i>	<i>No abnormality shall exist</i>
<i>Vibration withstanding</i>	<i>Vibration of 2,000 cycles per minute, 2mm amplitude, applied in X, Y and Z directions for 30 minutes each.</i>	<i>No abnormality shall exist</i>

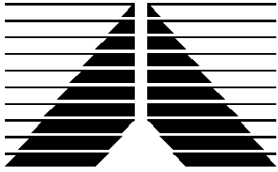

HITPOINT

TEL:886-2-2601-3311

FAX:886-2-2601-3898

NO.4 Lane 505, Zhongzheng Rd., Linkou Shiang, Taipei, Taiwan 24445 . R.O.C

7. PACKAGE METHOD

<1>1000pcs per tape reel , Total 10tape reels per carton (total 10000pcs per carton);

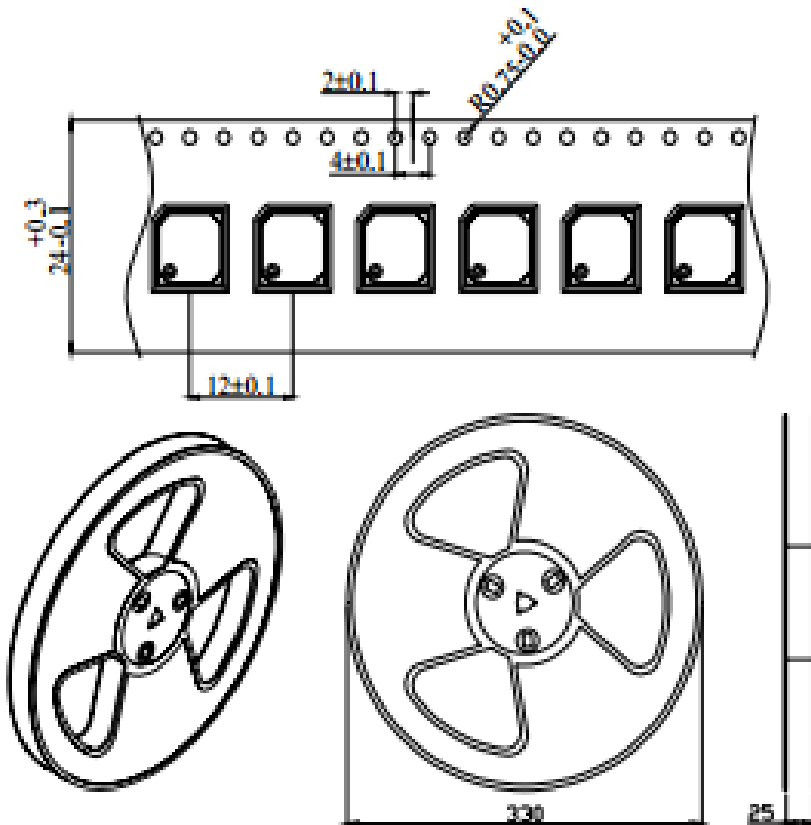

1 Reel: 1000 Pcs

Volume: L*W*H=360*360*360mm

< 2>N . W . : 4.0 KGS; G . W . : 8.0KGS;

< 3 > RoHS Mark: