



HITPOINT

TEL:8862-26013311

FAX:8862-26013898

NO.4 Lane 505, Zhongzheng Rd., Linkou Shiang, Taipei, Taiwan 24445 . R.O.C

Piezo Electric Sounder PT-3110WQ

(RoHS)

DATE:2009.05.11

1 . Electrical Characteristics

VER .3

Resonant Frequency (KHz)	1.1 \pm 0.5
Operating Voltage (Vp-p/max)	30
Rated Voltage (Vp-p)	5.0
Current Consumption (mA/max)	2.0 at Rated Voltage
Sound Pressure Level (dB/min)	85 at 10cm at Rated Voltage
Capacitance (pF)	48,000 \pm 30% at 120 Hz
Operating Temperature (°C)	-20 ~ +70
Storage Temperature (°C)	-30 ~ +80

PS : Vp-p = 1/2duty , square wave

2 . Typical Frequency Response Curve

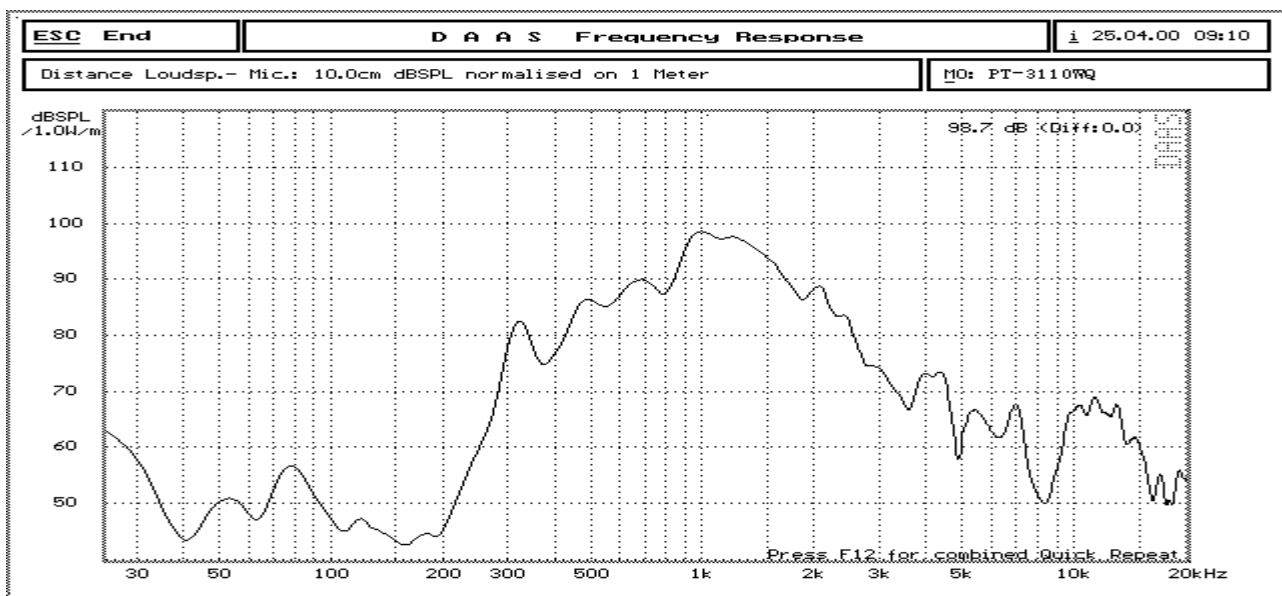



HITPOINT

TEL:8862-26013311

FAX:8862-26013898

NO.4 Lane 505, Zhongzheng Rd., Linkou Shiang, Taipei, Taiwan 24445 . R.O.C

3 . Dimensions and Material

3-1 Shape

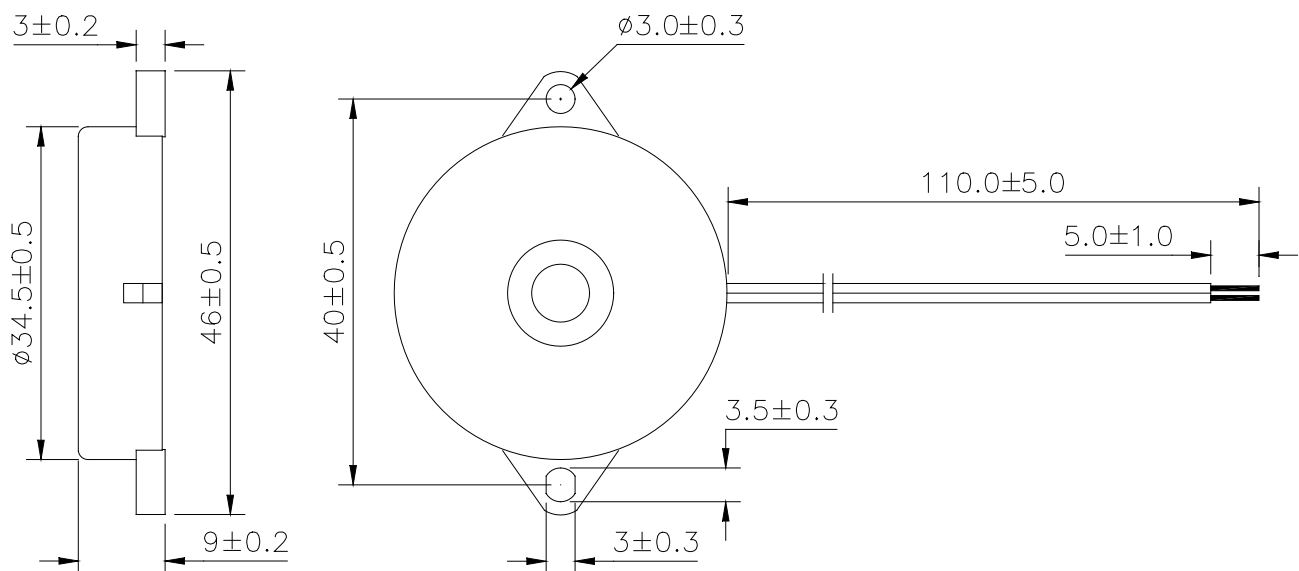

Unit:mm

3-2 Material

Housing	ABS 777D UL94HB plastic resin (Color : Black)
Leading Wire	28AWG (Red+Black)
Weight (Gram)	5.6



HITPOINT

TEL:8862-26013311

FAX:8862-26013898

NO.4 Lane 505, Zhongzheng Rd., Linkou Shiang, Taipei, Taiwan 24445 . R.O.C

4. TESTING METHOD

- **Standard Measurement conditions**

Temperature: 25 ± 2 °C Humidity: 45-60%

- **Acoustic Characteristics**

The oscillation frequency, current consumption and sound pressure are measured by the measuring instruments shown below.

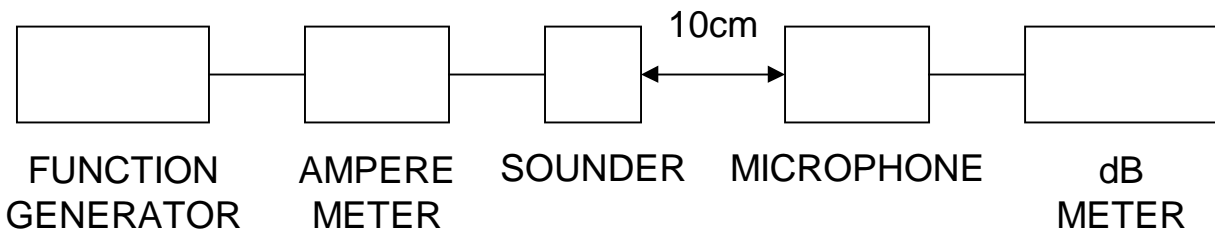

5. RELIABILITY

ITEMS	METHOD OF TEST AND MEASUREMENTS	PERFORMANCE
Coldness withstanding	After 98 hours of being exposed to -30 °C environment, should be returned to normal environment for 2 hours, then re-proceed to test.	No abnormality shall exist
Hotness withstanding	After 98 hours of being exposed to $+80$ °C environment, should be returned to normal environment for 2 hours, then re-proceed to test.	No abnormality shall exist
Humidity withstanding	After 98 hours of being exposed to 40 °C 95%RH environment in actual operation, should be returned to normal environment for 2 hours, then re-proceed to test.	No abnormality shall exist
Durability	Testing after 1,000 hours actual continuous operation. (at standard measurement conditions)	No abnormality shall exist
Drop withstanding	A natural drop from 75cm high down to the ground.	No abnormality shall exist
Vibration withstanding	Vibration of 2,000 cycles per minute, 2mm amplitude, applied in X, Y and Z directions for 30 minutes each.	No abnormality shall exist



HITPOINT

TEL:8862-26013311

FAX:8862-26013898

NO.4 Lane 505, Zhongzheng Rd., Linkou Shiang, Taipei, Taiwan 24445 . R.O.C

6. PACKAGE METHOD

<1> 200pcs per box, Total 10 boxes per carton, total 2000pcs carton;

Volume: L*W*H=520*335*290mm

<2>N . W . : ; 12.5KGS ; G . W . : 13.5GS ;

<3>RoHS Mark