

HITPOINT

TEL:8862-26013311

FAX:8862-26013898

NO.4 Lane 505, Zhongzheng Rd., Linkou Shiang, Taipei, Taiwan 24445 . R.O.C

Piezo Siren

PS-583Q

(ROHS)

DATE:2009.06.20

1 . Electrical Characteristics

VER .:2

Resonant Frequency (KHz)	1.5 ~ 3.5
Operating Voltage (Vdc)	5 ~ 15
Rated Voltage (Vdc)	12
Current Consumption (mA/max.)	300 at Rated Voltage
Sound Pressure Level (dB/min.)	100 at 100cm at Rated Voltage
Tone/Pulse Rate (Hz)	Sweep 3.3 ±20%
Operating Temperature (°C)	-20 ~ +70
Storage Temperature (°C)	-30 ~ +80

2 . Dimensions and Material

2-1 Shape

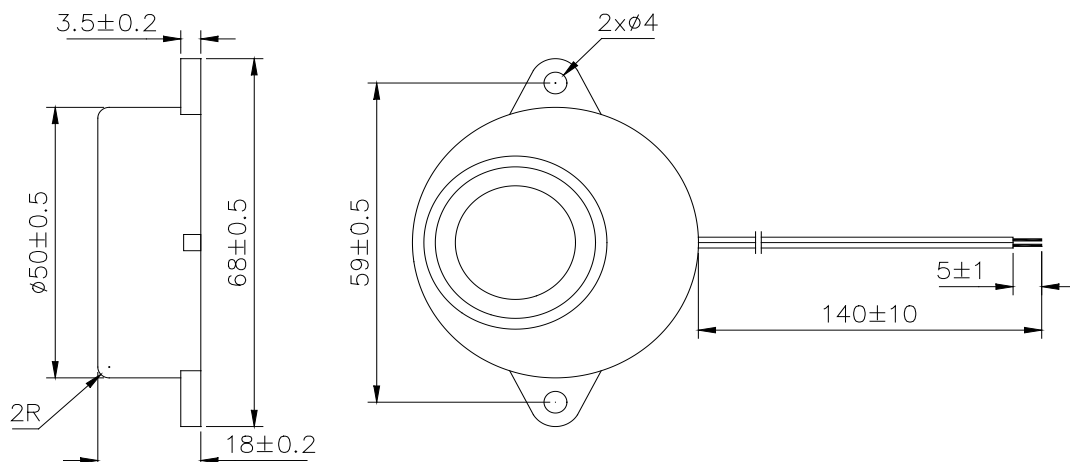

Unit : mm



HITPOINT

TEL:8862-26013311

FAX:8862-26013898

NO.4 Lane 505, Zhongzheng Rd., Linkou Shiang, Taipei, Taiwan 24445 . R.O.C

2-2 Material

Housing	ABS 777D UL94HB plastic resin (Color : Black)
Leading Wire	20 AWG
Weight (Gram)	25.8

3. TESTING METHOD

• *Standard Measurement conditions*

Temperature:25±2 °C Humidity:45-60%

• *Acoustic Characteristics*

The oscillation frequency, current consumption and sound pressure are measured by the measuring instruments shown below.

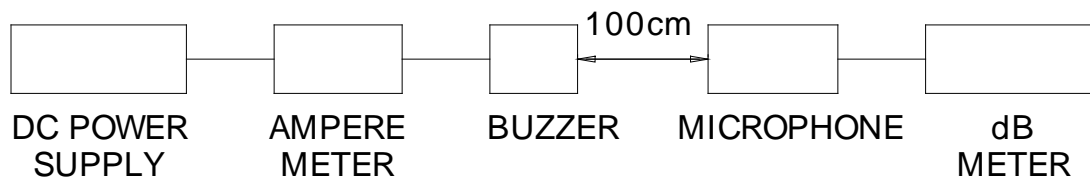



HITPOINT

TEL:8862-26013311

FAX:8862-26013898

NO.4 Lane 505, Zhongzheng Rd., Linkou Shiang, Taipei, Taiwan 24445 . R.O.C

4. RELIABILITY

ITEMS	METHOD OF TEST AND MEASUREMENTS	PERFORMANCE
<i>Coldness withstanding</i>	<i>After 98 hours of being exposed to -30 °C environment, should be returned to normal environment for 2 hours, then re-proceed to test.</i>	<i>No abnormality shall exist</i>
<i>Hotness withstanding</i>	<i>After 98 hours of being exposed to +80 °C environment, should be returned to normal environment for 2 hours, then re-proceed to test.</i>	<i>No abnormality shall exist</i>
<i>Humidity withstanding</i>	<i>After 98 hours of being exposed to 40 °C 95%RH environment in actual operation, should be returned to normal environment for 2 hours, then re-proceed to test.</i>	<i>No abnormality shall exist</i>
<i>Durability</i>	<i>10sec on/10sec off ; 1000hours(180000 cycles)</i>	<i>No abnormality shall exist</i>
<i>Vibration withstanding</i>	<i>Linear vibrate frequency rate: 5~55Hz Time:180sec , applied in X, Y and Z directions for 3 times each.</i>	<i>No abnormality shall exist</i>

5. PACKAGE METHOD

<1> 70pcs per box , Total 10 boxes per carton , total 700pcs carton;

Volume: L*W*H=520*335*290mm

<2> N . W . : ; 18.1KGS ; G . W . : 20.1KGS ;

<3> RoHS Mark: