

HITPOINT

TEL:8862-26013311

FAX:8862-26013898

NO.4 Lane 505, Zhongzheng Rd., Linkou Shiang, Taipei, Taiwan 24445 . R.O.C

Piezo Siren

PS-520Q

(ROHS)

DATE:2009.06.05

1 . Electrical Characteristics

VER.:3

Resonant Frequency (KHz)	3.0 ±0.5
Operating Voltage (Vdc)	5 ~ 15
Rated Voltage (Vdc)	12
Current Consumption (mA/max.)	200 at Rated Voltage
Sound Pressure Level (dB/min.)	105 at 100cm at Rated Voltage
Tone/Pulse Rate (Hz)	Constant
Operating Temperature (°C)	-20 ~ +70
Storage Temperature (°C)	-30 ~ +80

2 . Dimensions and Material

2-1 Shape

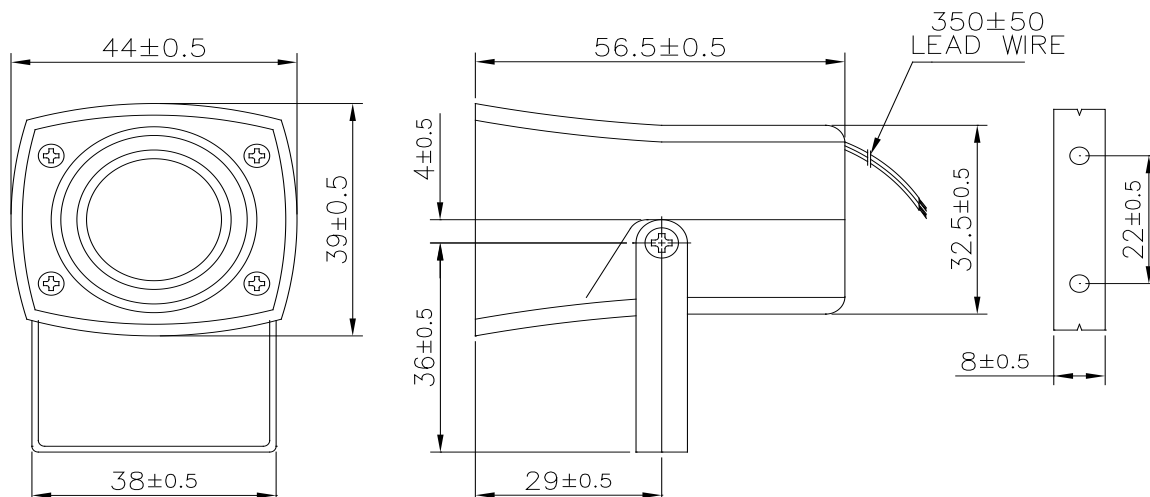

Unit : mm



HITPOINT

TEL:8862-26013311

FAX:8862-26013898

NO.4 Lane 505, Zhongzheng Rd., Linkou Shiang, Taipei, Taiwan 24445 . R.O.C

2-2 Material

Housing	ABS 757 UL94HB plastic resin (Color : Black)
Leading Wire	20 AWG
Weight (Gram)	52.2

3. TESTING METHOD

· *Standard Measurement conditions*

Temperature: 25 ± 2 °C Humidity: 45-60%

· *Acoustic Characteristics*

The oscillation frequency, current consumption and sound pressure are measured by the measuring instruments shown below.

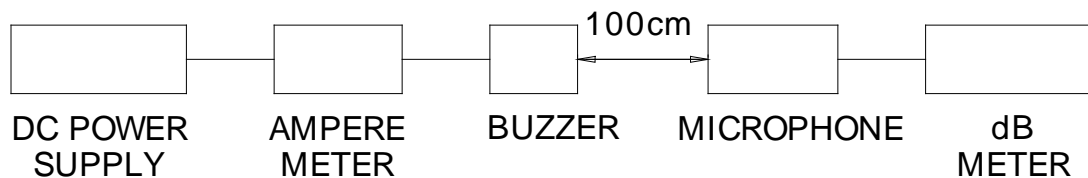



HITPOINT

TEL:8862-26013311

FAX:8862-26013898

NO.4 Lane 505, Zhongzheng Rd., Linkou Shiang, Taipei, Taiwan 24445 . R.O.C

4. RELIABILITY

ITEMS	METHOD OF TEST AND MEASUREMENTS	PERFORMANCE
<i>Coldness withstanding</i>	<i>After 98 hours of being exposed to -30℃ environment, should be returned to normal environment for 2 hours, then re-proceed to test.</i>	<i>No abnormality shall exist</i>
<i>Hotness withstanding</i>	<i>After 98 hours of being exposed to +80℃ environment, should be returned to normal environment for 2 hours, then re-proceed to test.</i>	<i>No abnormality shall exist</i>
<i>Humidity withstanding</i>	<i>After 98 hours of being exposed to 40℃ 95%RH environment in actual operation, should be returned to normal environment for 2 hours, then re-proceed to test.</i>	<i>No abnormality shall exist</i>
<i>Durability</i>	<i>10sec on/10sec off ; 1000hours(180000 cycles)</i>	<i>No abnormality shall exist</i>
<i>Vibration withstanding</i>	<i>Linear vibrate frequency rate: 5~55Hz Time:180sec , applied in X, Y and Z directions for 3 times each.</i>	<i>No abnormality shall exist</i>

5. PACKAGE METHOD

- <1> One inner box consists of 1pcs.
- <2> 250pcs of PS-520 Qare packed in a carton box. (L*W*H=520*335*290mm)
- <3> N . W . : ; 13.1KGS ; G . W . : 17.5KGS ;
- <4> RoHS Mark: