



**WINSTAR Display Co.,Ltd.**  
**華凌光電股份有限公司**



# Winstar Display Co., LTD

## 華凌光電股份有限公司



WEB: <https://www.winstar.com.tw> E-mail: sales@winstar.com.tw

### SPECIFICATION

**CUSTOMER :** \_\_\_\_\_

**MODULE NO.:** WF101LSYAPLNGO#

<p><b>APPROVED BY:</b></p> <p>( FOR CUSTOMER USE ONLY )</p>	<p><b>PCB VERSION:</b> _____</p> <p><b>DATA:</b> _____</p>
---	--

SALES BY	APPROVED BY	CHECKED BY	PREPARED BY
			葉虹蘭
<b>ISSUED DATE: 2023/03/01</b>			

TFT Display Inspection Specification: <https://www.winstar.com.tw/technology/download.html>

Precaution in use of TFT module: <https://www.winstar.com.tw/technology/download/declaration.html>

**RECORDS OF REVISION**

DOC. FIRST ISSUE

VERSION	DATE	REVISED PAGE NO.	SUMMARY
0	2021/11/09		First issue
A	2021/12/02		Add Backlight Driving Part Modify General Specifications & Current Consumption
B	2022/01/27		Modify CN
C	2023/02/02		Modify Static electricity test
D	2023/03/01		Correct LVDS Input Timing Table

# Contents

1.Module Classification Information

2.Summary

3.General Specifications

4.Absolute Maximum Ratings

5.Electrical Characteristics

6.AC Characteristics

7.LVDS Input Timing Table

8.Power Sequence

9.Optical Characteristics

10.Interface

11.Reliability

12.Touch Panel Information

13.Contour Drawing

14.Other

# 1.Module Classification Information

W F 101 L S Y A P L N G 0 #  
 ① ② ③ ④ ⑤ ⑥ ⑦ ⑧ ⑨ ⑩ ⑪ ⑫ ⑬

①	Brand : WINSTAR DISPLAY CORPORATION											
②	Display Type : F→TFT Type, J→Custom TFT											
③	Display Size : 10.1” TFT											
④	Model serials no.											
⑤	Backlight Type :	F→CCFL, White S→LED, High Light White					T→LED, White Z→Nichia LED, White					
⑥	LCD Polarize Type/ Temperature range/ Gray Scale Inversion Direction	A→Transmissive, N.T, IPS TFT C→Transmissive, N. T, 6:00 ; F→Transmissive, N.T,12:00 ; I→Transmissive, W. T, 6:00 K→Transflective, W.T,12:00 L→Transmissive, W.T,12:00 N→Transmissive, Super W.T, 6:00					Q→Transmissive, Super W.T, 12:00 R→Transmissive, Super W.T, O-TFT V→Transmissive, Super W.T, VA TFT W→Transmissive, Super W.T, IPS TFT X→Transmissive, W.T, VA TFT Y→Transmissive, W.T, IPS TFT Z→Transmissive, W.T, O-TFT					
⑦	A : TFT LCD B : TFT+SCREW HOLES+CONTROL BOARD C : TFT+ SCREW HOLES +A/D BOARD D : TFT+ SCREW HOLES +A/D BOARD+CONTROL BOARD E : TFT+ SCREW HOLES +POWER BOARD					F : TFT+CONTROL BOARD G : TFT+ SCREW HOLES H : TFT+D/V BOARD I : TFT+ SCREW HOLES +D/V BOARD J : TFT+POWER BD						
⑧	Resolution:											
	A	128160	B	320234	C	320240	D	480234	E	480272	F	640480
	G	800480	H	1024600	I	320480	J	240320	K	800600	L	240400
	M	1024768	N	128128	P	1280800	Q	480800	R	640320	S	480128
	T	800320	U	8001280	V	176220	W	1280398	X	1024250	Y	1920720
	Z	800200	2	1024324	3	7201280	4	19201200	5	1366768	6	1280320
⑨	D: Digital L : LVDS M:MIPI											
⑩	Interface:											
	N	Without control board			A	8Bit		B	16Bit		H	HDMI
	I	I2C Interface			R	RS232		S	SPI Interface		U	USB
⑪	TS:											
	N	Without TS			T	Resistive touch panel			C	Capacitive touch panel (G-F-F)		
	G	Capacitive touch panel (G-G)					C1	Capacitive touch panel (G-F-F)+OCA				
	C2	Capacitive touch panel (G-F-F)+OCR					G1	Capacitive touch panel (G-G)+OCA				
	G2	Capacitive touch panel (G-G)+OCR					B	CTP+GG+USB				
⑫	Version: X:Raspberry pi											
⑬	Special Code #:Fit in with ROHS directive regulations											

--	--	--

WINSTAR DISPLAY Co., Ltd.

## **2.Summary**

TFT 10.1” is a color active matrix thin film transistor (TFT) liquid crystal display (LCD) that uses amorphous silicon TFT as a switching device. This model is composed of a TFT LCD panel, a driving circuit and a back light system. This TFT LCD has a 10.1 inch diagonally measured active display area with HD (1280 horizontal by 800 vertical pixel) resolution.

WINSTAR DISPLAY Co., Ltd.

### 3. General Specifications

Item	Dimension	Unit
Screen Diagonal	10.1	inch
Number of Pixels	1280 x 3(R GB) x 800	dots
Module dimension	257.96 x 168.6 x 9.48	mm
Active area	216.96 (H) x 135.6(V)	mm
Pixel pitch	0.1695 x 0.1695	mm
Display Mode	Normally Black , Transmissive	
Viewing Angle	80/80/80/80	
Pixel Arrangement	R.G.B. Vertical Stripe	
TFT Drive IC	EK79202B1 or Equivalent	
Backlight Type	LED, Normally White	
Aspect Ratio	16:10	
TFT Interface	LVDS	
CTP FW Version	80	
CTP IC	GT928 or equivalent	
CTP Interface	I2C	
CTP Resolution	1280*800	
With /Without TP	With CTP	
Surface	Glare	

\*Color tone slight changed by temperature and driving voltage.



## **4. Absolute Maximum Ratings**

Item	Symbol	Min	Typ	Max	Unit
Operating Temperature	TOP	-20	—	+70	°C
Storage Temperature	TST	-30	—	+80	°C

Note: Device is subject to be damaged permanently if stresses beyond those absolute maximum ratings listed above

1. Temp.  $\leq 60^{\circ}\text{C}$ , 90% RH MAX. Temp.  $> 60^{\circ}\text{C}$ , Absolute humidity shall be less than 90% RH at  $60^{\circ}\text{C}$

WINSTAR DISPLAY Co., Ltd.

# 5. Electrical Characteristics

## 5.1. Typical Operation Conditions (Note 1)

Item	Symbol	Values			Unit	Remark
		Min.	Typ.	MAX.		
Power voltage	VCC	3.0	3.3	3.5	V	
	VGH		18		V	Note 1
	VGL		-10		V	Note 2
	VSP		5.5		V	Note 3
	VSN		-5.5		V	Note 3
Supply Voltage For Touch Logic	VDDT	2.8	—	3.3	V	

Note:

1. VGH is TFT Gate operating Voltage.

2. VGL is TFT Gate operating Voltage.

3. VSP / VSN does not require an external power supply voltage, it is provided by IC on the PCB

## 5.2. Current Consumption

Item	Symbol	Values			Unit	Remark
		Min.	Typ.	MAX.		
Current for Driver	IGH	—	7.7	—	mA	VGH = 18V
	IGL	—	7.7	—	mA	VGL = -10V
	IVCC	—	85	130	mA	—

### 5.3. Backlight Characteristics

Parameter	Symbol	Min.	Typ.	Max.	Unit	Remark
Supply voltage of white LED backlight	VL	10.8	12.8	13.6	V	Note 1
Current for LED backlight	IL	—	480	—	mA	
LED life time	-	50000	-	-	Hr	Note 1

Note 1 : There are 1 Groups LED

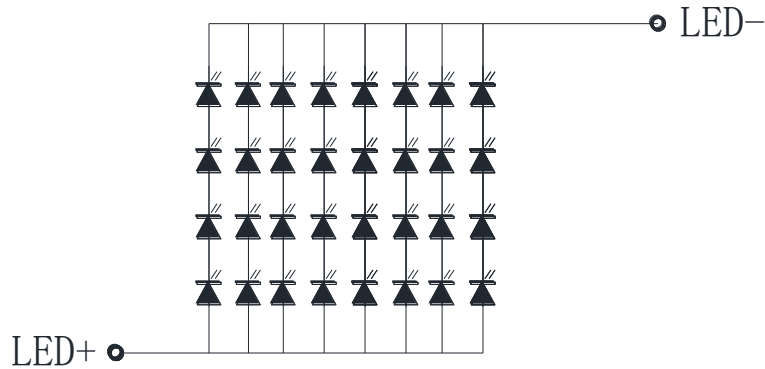

Note 2 :  $T_a = 25\text{ }^\circ\text{C}$

Note 3 : Brightness to be decreased to 50% of the initial value

Note 4 : The single LED lamp case

# 6.AC Characteristics

## 6.1. LVDS mode AC electrical characteristics

Parameter	Symbol	Spec.			Unit	Condition
		Min.	Typ.	Max.		
Clock frequency	$R_{xFCLK}$	30	-	TBD	MHz	Refer to input timing table for each display resolution
Input data skew margin	$T_{RSKM}$	500	†	-	ps	$ VID  = 200mV$ $R_{xVCM} = 1.2V$ $R_{xFCLK} = 81MHz$
Clock high time	$T_{LVCH}$	-	$4/(7 * R_{xFCLK})$	-	ns	
Clock low time	$T_{LVCL}$	-	$3/(7 * R_{xFCLK})$	-	ns	
PLL wake-up time	$T_{enPLL}$	-	-	150	us	

Table 1: LVDS mode AC electrical characteristics

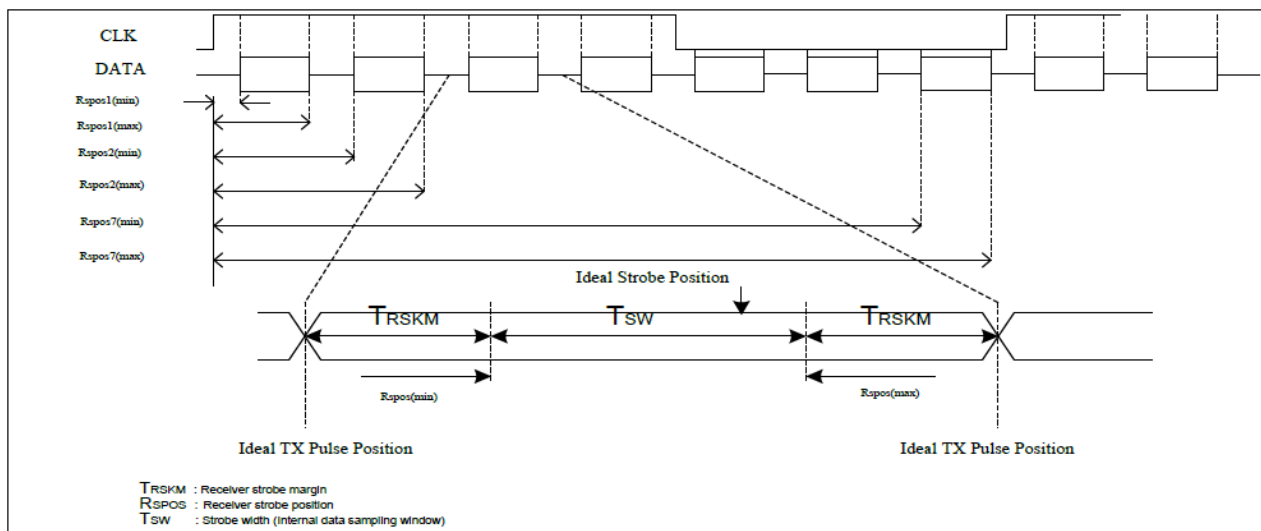
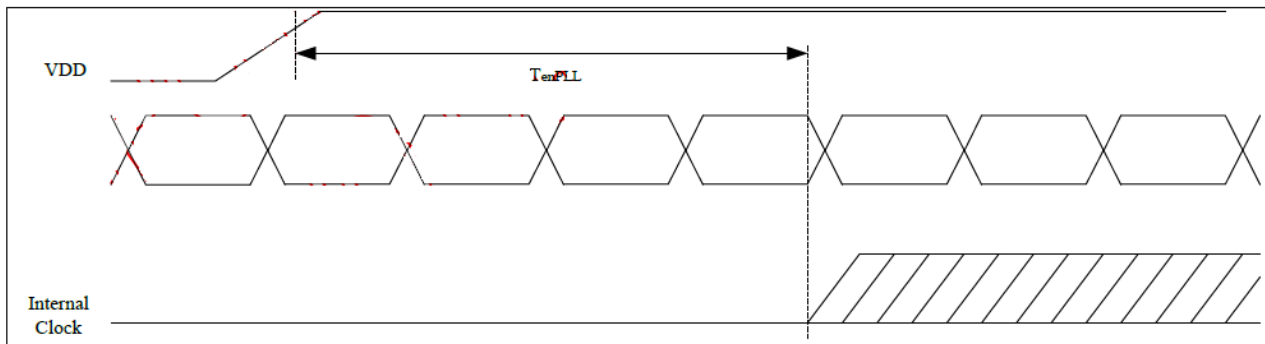
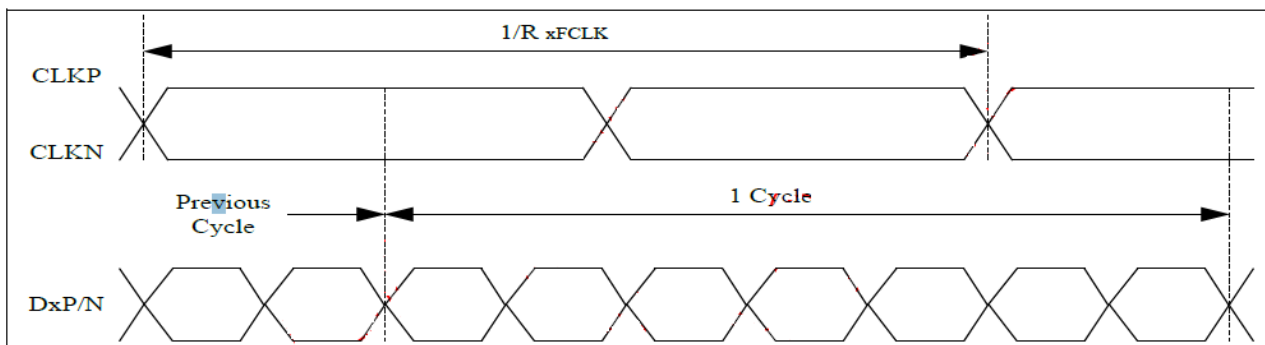

Figure 1: LVDS figure

WINSTAR DISPLAY Co., Ltd.

# 7.LVDS Input Timing Table

For 1280RGBx800 timing table

Parameter	Symbol	Value			Unit
		Min.	Typ.	Max.	
DCLK frequency @Frame rate=60Hz (LVDS)	$F_{DCLK}$	68.2	72.4	78.4	MHz
Horizontal display area	$T_{HD}$	1280			DCLK
HSYNC period time	$T_H$	1380	1440	1500	DCLK
HSYNC blanking	$T_{HBP}+T_{HFP}$	100	160	220	DCLK
Vertical display area	$T_{VD}$	800			H
VSYNC period time	$T_V$	824	838	872	H
VSYNC blanking	$T_{VBP}+T_{VFP}$	24	38	72	H

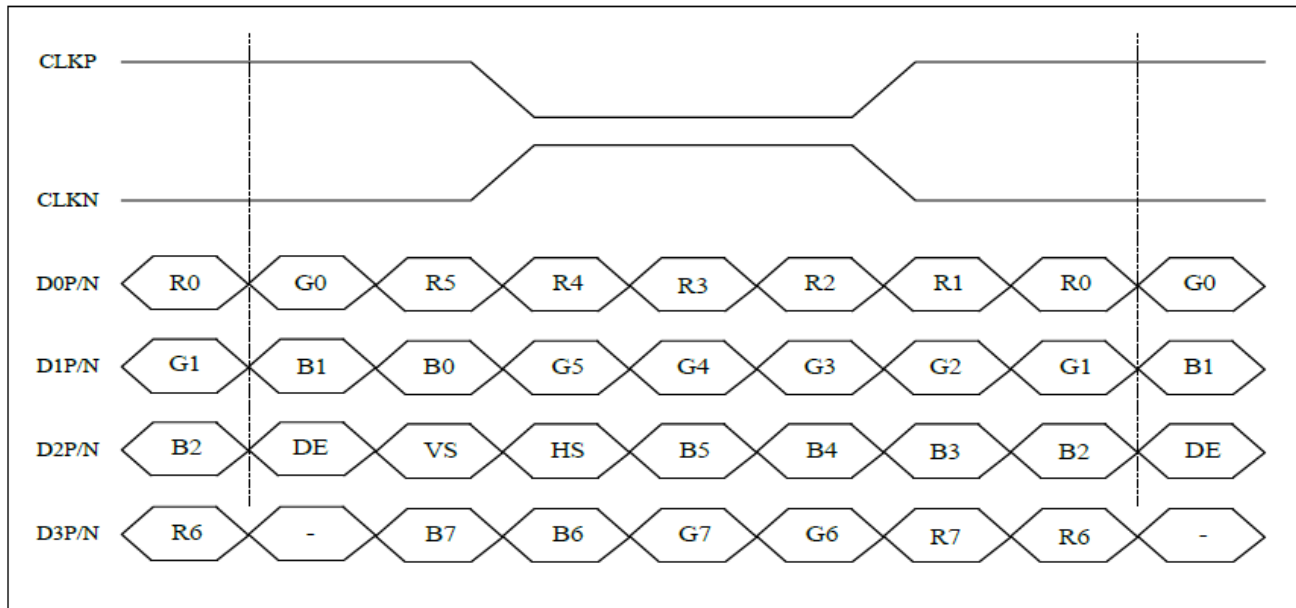

8-bit LVDS input

## Vertical timing

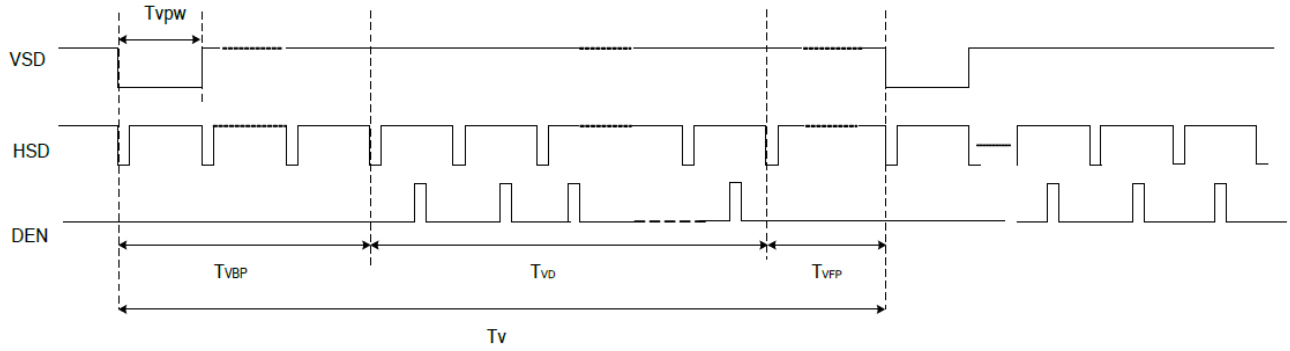

## Horizontal timing

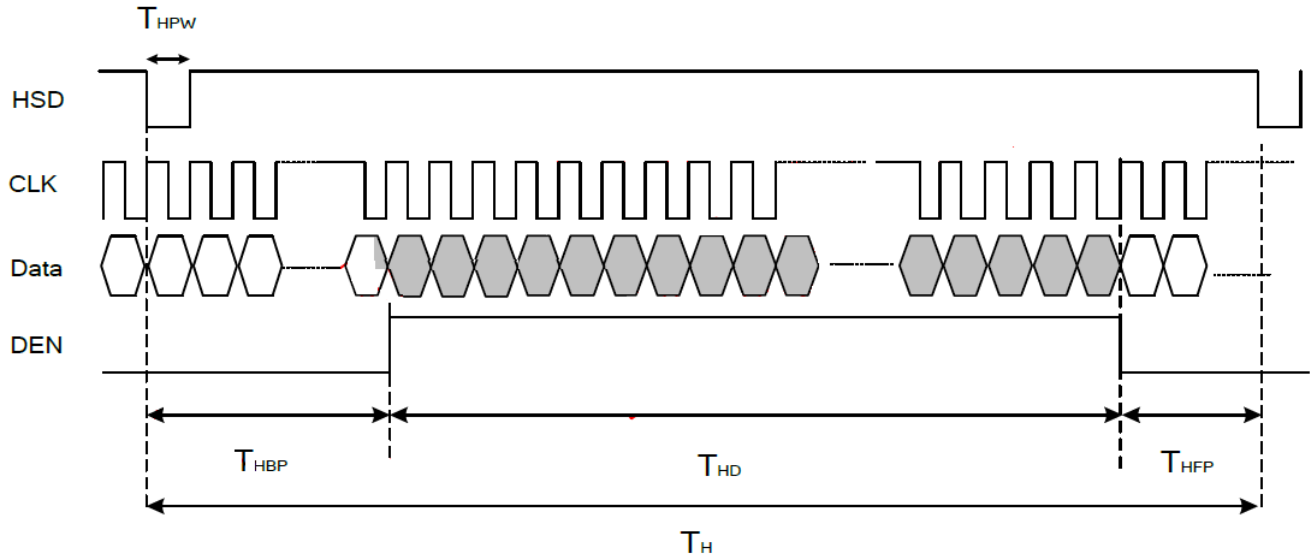

WINSTAR L

# 8. Power Sequence

## 8.1. Power Generation

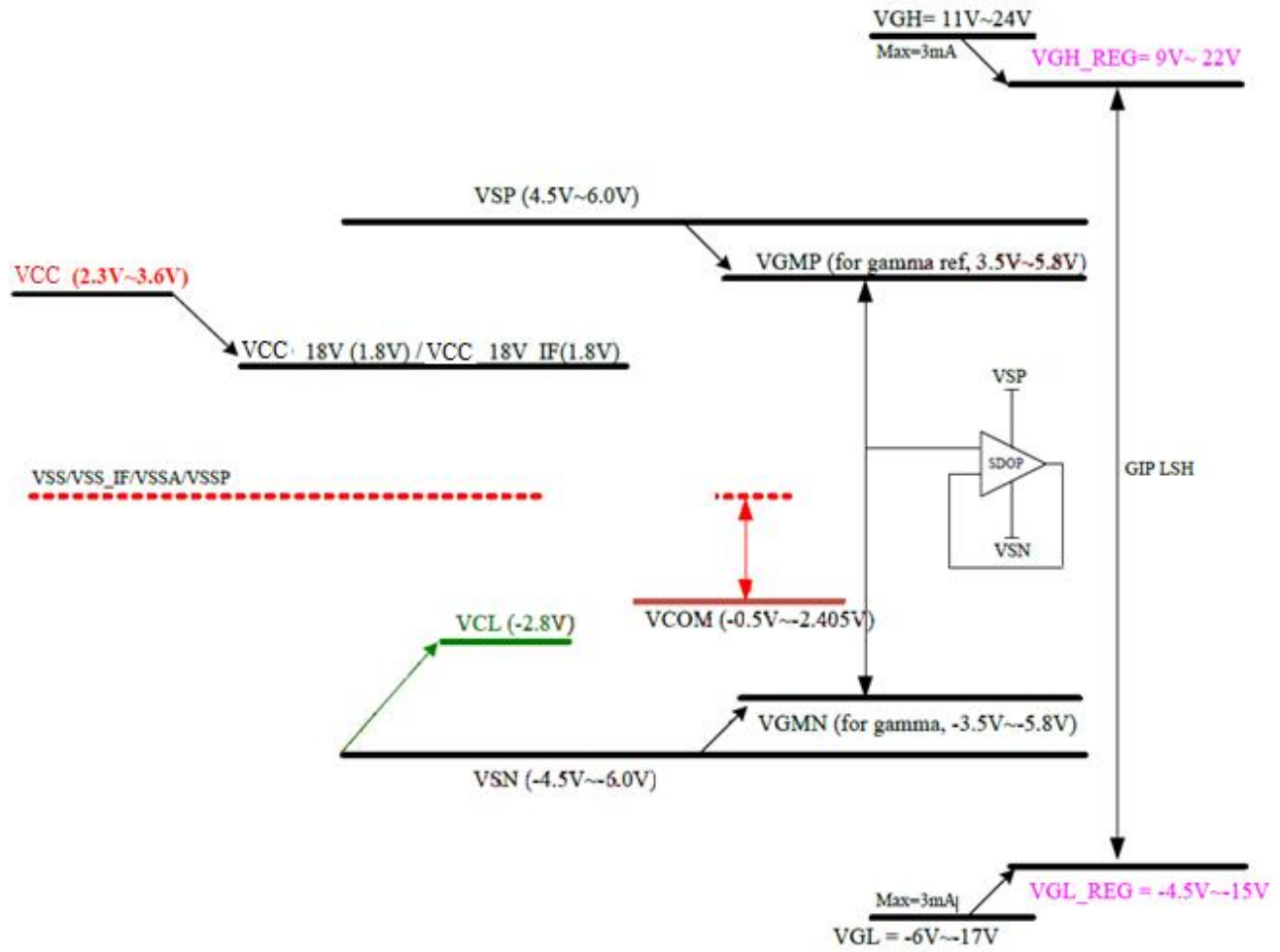
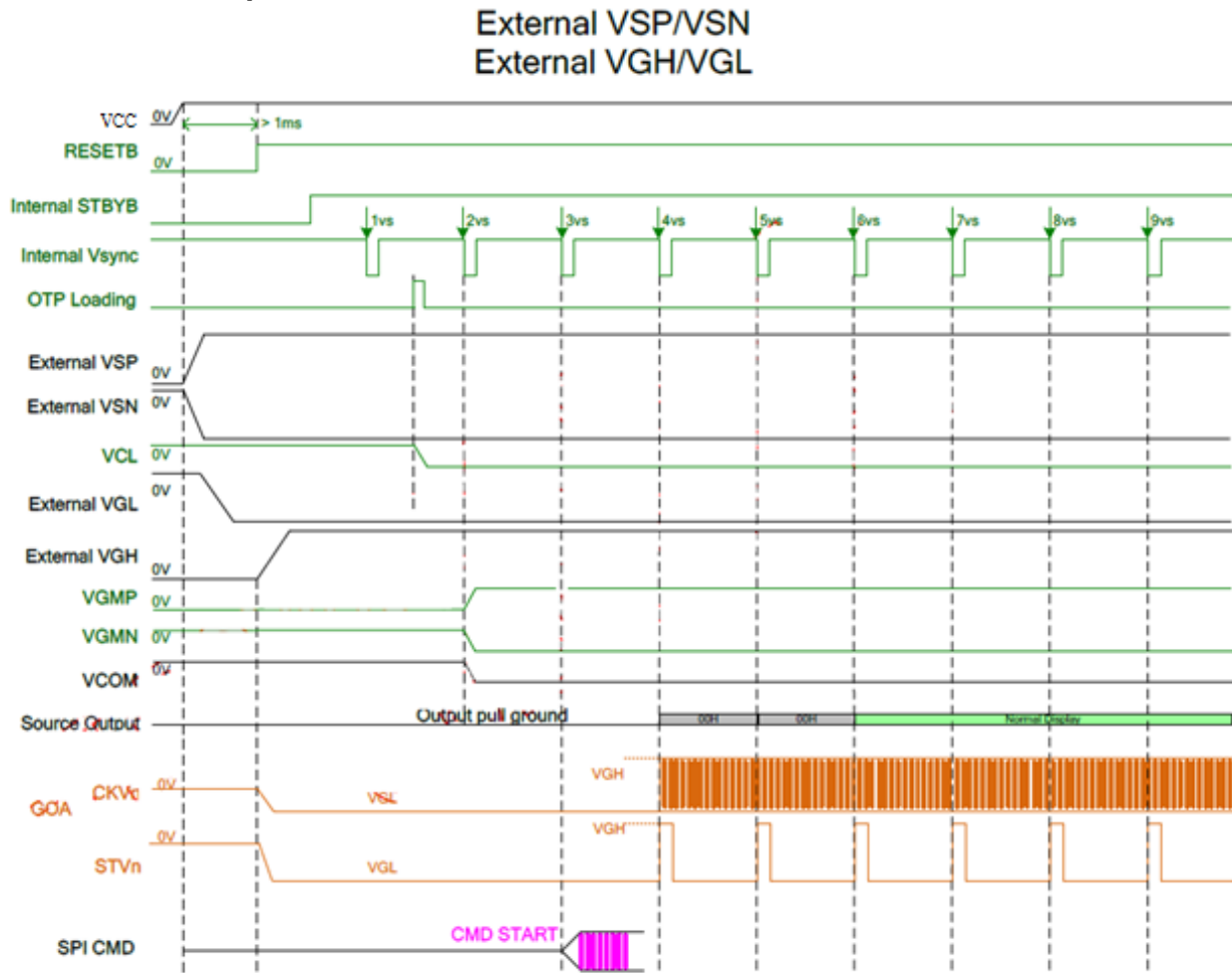

Figure 1 power generation



## 8.2. Power on sequence



WINSTAR L

### 8.3. Power off sequence

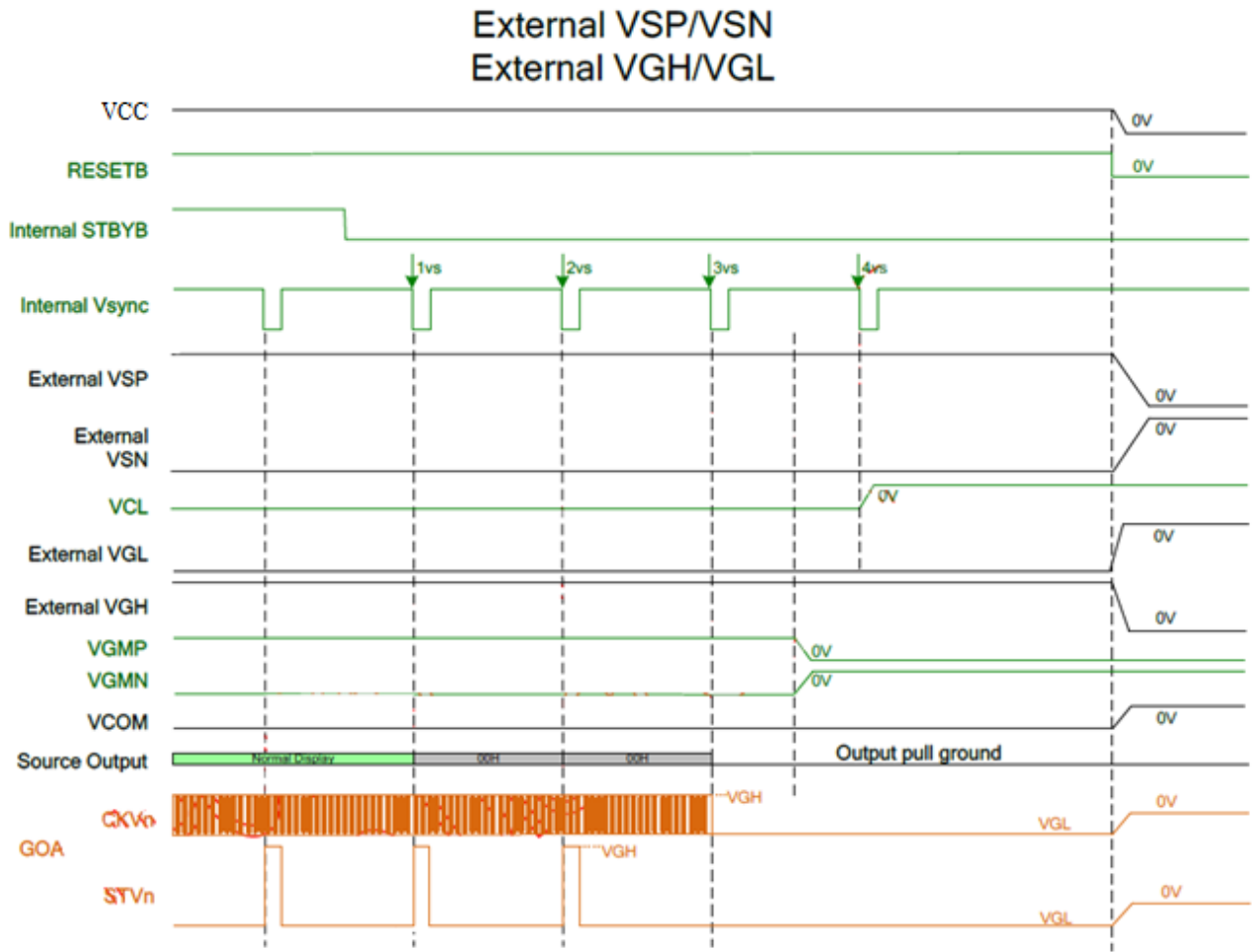

WINSTAR L

# 9. Optical Characteristics

Item	Symbol	Condition.	Min	Typ.	Max.	Unit	Remark	
Response time	Tr+ Tf	$\theta=0^\circ$ 、 $\phi=0^\circ$	-	25	35	.ms	Note 3	
Contrast ratio	CR	At optimized viewing angle	800	1000	-	-	Note 4	
Color Chromaticity	White	Wx	$\theta=0^\circ$ 、 $\phi=0^\circ$	0.272	0.322	0.372	-	Note 2,6,7
		Wy		0.294	0.344	0.394	-	
Viewing angle	Hor.	$\Theta_R$	$CR \geq 10$	70	80	-	Deg.	Note 1
		$\Theta_L$		70	80	-		
	Ver.	$\Phi_T$		70	80	-		
		$\Phi_B$		70	80	-		
Brightness	-	-	800	900	-	cd/m <sup>2</sup>	Center of display	
Uniformity	(U)	-	70	-	-	%	Note 5	

Ta=25±2°C

Note 1: Definition of viewing angle range

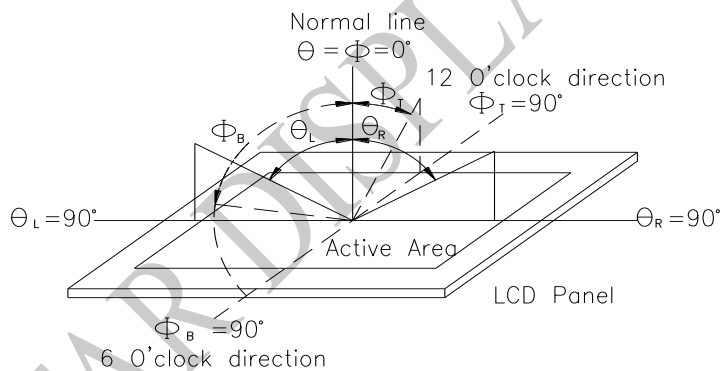

Fig. 9.1. Definition of viewing angle

Note 2: Test equipment setup:

After stabilizing and leaving the panel alone at a driven temperature for 10 minutes, the measurement should be executed. Measurement should be executed in a stable, windless, and dark room. Optical specifications are measured by Topcon BM-7 or BM-5 luminance meter 1.0° field of view at a distance of 50cm and normal direction.

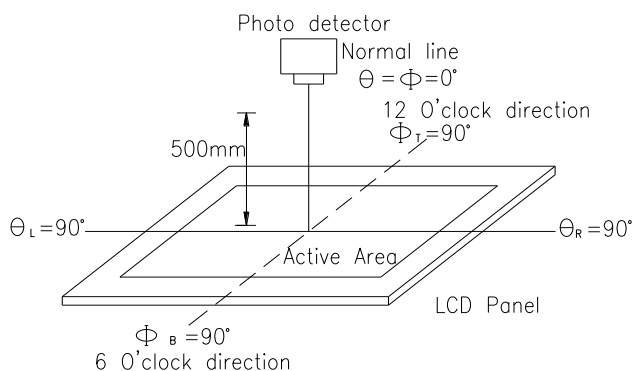
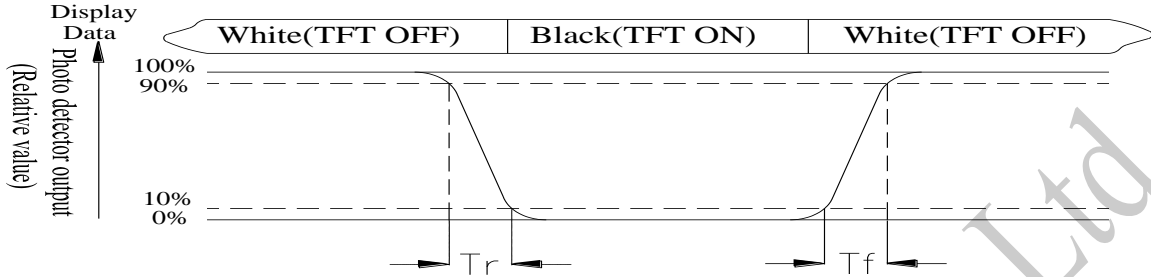

Fig. 9.2. Optical measurement system setup

**Note 3: Definition of Response time:**

The response time is defined as the LCD optical switching time interval between “White” state and “Black” state. Rise time,  $T_r$ , is the time between photo detector output intensity changed from 90% to 10%. And fall time,  $T_f$ , is the time between photo detector output intensity changed from 10% to 90%



**Note 4: Definition of contrast ratio:**

The contrast ratio is defined as the following expression.

$$\text{Contrast ratio (CR)} = \frac{\text{Luminance measured when LCD on the "White" state}}{\text{Luminance measured when LCD on the "Black" state}}$$

**Note 5: Definition of Luminance Uniformity**

Active area is divided into 9 measuring areas (reference the picture in below). Every measuring point is placed at the center of each measuring area.

$$\text{Luminance Uniformity (U)} = \text{Lmin/Lmax} \times 100\%$$

L = Active area length

W = Active area width

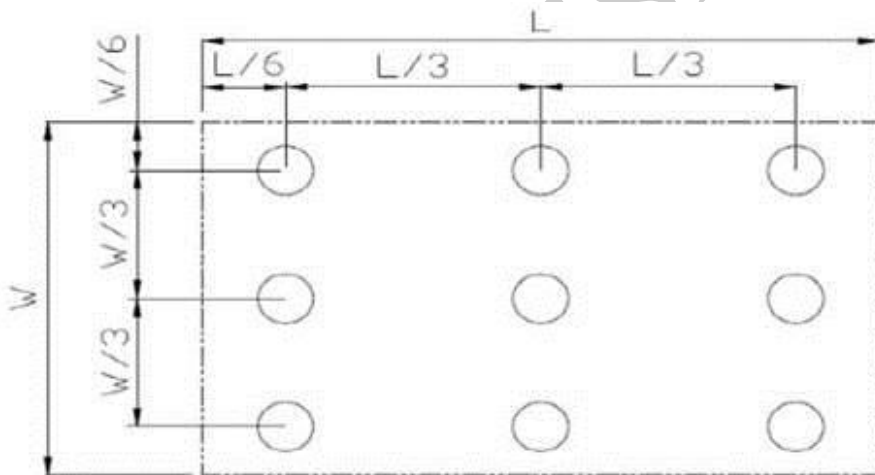

Fig9.3. Definition of uniformity

**Note 6: Definition of color chromaticity (CIE 1931)**

Color coordinates measured at the center point of LCD

**Note 7:** Measured at the center area of the panel when all the input terminals of LCD panel are electrically opened.

# 10. Interface

## 10.1. Interface Connector

A 40pin connector is used for the module electronics interface. The recommended model is F62240-H1210B manufactured by Vigorconn.

Pin No.	Symbol	I/O	Function	Remark
1	NC	-	No connection	
2	VCC	P	Power Supply	
3	VCC	P	Power Supply	
4	NC	-	No connection	
5	NC	-	No connection	
6	NC	-	No connection	
7	GND	P	Ground	
8	Rxin0-	I	-LVDS Differential Data Input	R0-R5,G0
9	Rxin0+	I	+LVDS Differential Data Input	
10	GND	P	Ground	
11	Rxin1-	I	-LVDS Differential Data Input	G1G5,B0,B1
12	Rxin1+	I	+LVDS Differential Data Input	
13	GND	P	Ground	
14	Rxin2-	I	-LVDS Differential Data Input	B2-B5,HS,VS, DE
15	Rxin2+	I	+LVDS Differential Data Input	
16	GND	P	Ground	
17	RxCLK-	I	-LVDS Differential Clock Input	LVDS CLK
18	RxCLK+	I	+LVDS Differential Clock Input	
19	GND	P	Ground	
20	Rxin3-	I	-LVDS Differential Data Input	R6,R7,G6,G7, B6,B7
21	Rxin3+	I	+LVDS Differential Data Input	
22	GND	P	Ground	
23	NC	-	No connection	
24	NC	-	No connection	
25	GND	P	Ground	
26	NC	-	No connection	
27	NC	-	No connection	
28	NC	-	No connection	
29	NC	-	No connection	

30	GND	P	Ground	
31	NC	-	No connection	
32	NC	-	No connection	
33	NC	-	No connection	
34	NC	-	No connection	
35	VGL	P	Gate OFF Voltage	
36	NC	-	No connection	
37	NC	-	No connection	
38	VGH	P	Gate ON Voltage	
39	NC	-	No connection	
40	NC	-	No connection	

I: input, O: output, P: Power

### 10.2. CTP PIN Definition

Pin	Symbol	Function	Remark
1	SDA	I2C data input and output	
2	SCL	I2C clock input	
3	RST	External Reset, Low is active	
4	INT	External interrupt to the host	
5	VDDT	Power Supply : +3.3V	
6	VSS	Ground for analog circuit	

### 10.3. Backlight Driving Part

Pin No.	Symbol	Function
1	LED+	Red, LED_ Anode
2	LED-	Black, LED_ Cathode

Note: The backlight interface connector is a model A3501Y-02(BH-Y) or equivalent

# 11. Reliability

Content of Reliability Test (Wide temperature, -20°C~70°C)

Environmental Test			
Test Item	Content of Test	Test Condition	Note
High Temperature storage	Endurance test applying the high storage temperature for a long time.	80°C 200hrs	2
Low Temperature storage	Endurance test applying the low storage temperature for a long time.	-30°C 200hrs	1,2
High Temperature Operation	Endurance test applying the electric stress (Voltage & Current) and the thermal stress to the element for a long time.	70°C 200hrs	—
Low Temperature Operation	Endurance test applying the electric stress under low temperature for a long time.	-20°C 200hrs	1
High Temperature/ Humidity Operation	The module should be allowed to stand at 60°C,90%RH max	60°C,90%RH 96hrs	1,2
Thermal shock resistance	The sample should be allowed stand the following 10 cycles of operation <div style="text-align: center;"> <p style="margin: 0;">-20°C    25°C    70°C</p> <p style="margin: 0;">30min    5min    30min</p> <p style="margin: 0;">1 cycle</p> </div>	-20°C/70°C 10 cycles	—
Vibration test	Endurance test applying the vibration during transportation and using.	Total fixed amplitude : 1.5mm Vibration Frequency : 10~55Hz One cycle 60 seconds to 3 directions of X,Y,Z for Each 15 minutes	3
Static electricity test	Endurance test applying the electric stress to the finished product housing.	Contact ±6KV Air ±8KV RS=330Ω CS=150pF 10 times	4

Note1: No dew condensation to be observed.

Note2: The function test shall be conducted after 4 hours storage at the normal Temperature and humidity after remove from the test chamber.

Note3: The packing have to including into the vibration testing.

# 12.Touch Panel Information

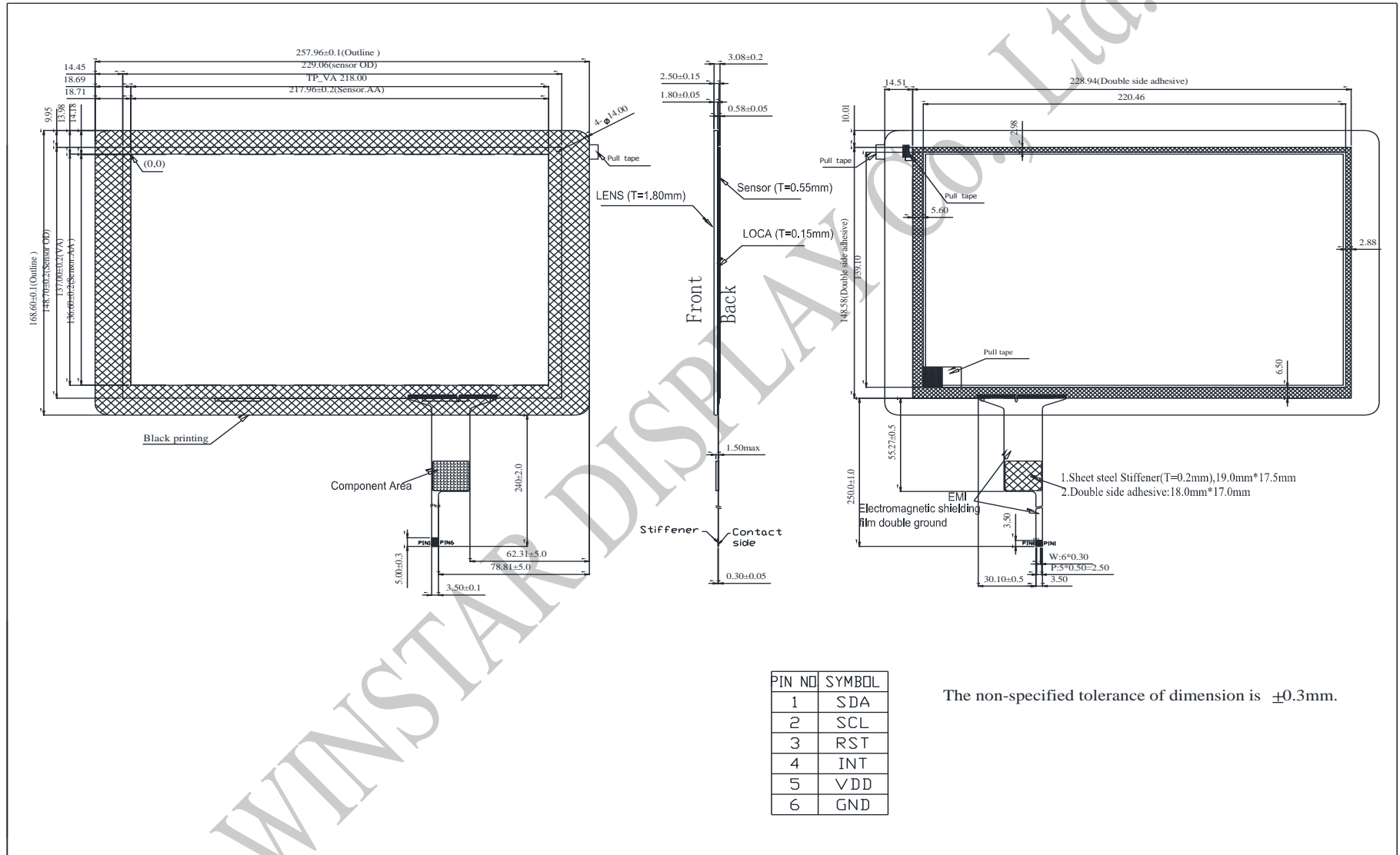



## 12.1. Timing for Read Operation

First, set address pointer based on the aforesaid Write Operation timing sequence. Then, resend

Start condition to perform Read addressing and read data in the registers.



Address\_R: Slave address with Read control bit.

NACK: Host issues NACK after reading the last byte.

After setting Read addresses, the host can read one or more than one byte at a time.

GT927/GT928/GT9110 will automatically increase the address pointer and send subsequent data in sequence.

The Stop condition (the first E signal as shown in the above diagram) after setting the address pointer is optional. However, the repeated Start condition has to be sent.

## 12.2. Coordinate registers

Addr	Access	bit7	bit6	bit5	bit4	bit3	bit2	bit1	bit0
0x8140	R	Product ID( first Byte, ASCII )							
0x8141	R	Product ID( second Byte, ASCII)							
0x8142	R	Product ID( third Byte, ASCII)							
0x8143	R	Product ID( forth Byte, ASCII)							
0x8144	R	Firmware version(HEX.low byte)							
0x8145	R	Firmware version (HEX.high byte)							
0x8146	R	x coordinate resolution (low byte)							
0x8147	R	x coordinate resolution (high byte)							
0x8148	R	y coordinate resolution (low byte)							
0x8149	R	y coordinate resolution (high byte)							

0x814A	R	Vendor_id(ID of the current module)				
0x814B	R	Reserved				
0x814C	R	Reserved				
0x814D	R	Reserved				
0x814E	R/W	buffer status	large detect	Reserved	HaveKey	number of touch points
0x814F	R	track id as 32 indicates HotKnot proximity detection signal				
0x8150	R	PxyOk	Reserved			
0x8151	R	PxyOk	Reserved			
0x8152	R	Reserved				
0x8153	R	Reserved				
0x8154	R	Reserved				
0x8155	R	Reserved				
0x8156	R	Reserved				
0x8157	R	pen_sta	Reserved			track id
0x8158	R	point 1 x coordinate (low byte)				
0x8159	R	point 1 x coordinate (high byte)				
0x815A	R	point 1 y coordinate (low byte)				
0x815B	R	point 1 y coordinate (high byte)				
0x815C	R	Point 1 size (low byte)				
0x815D	R	point 1 size (high byte)				
0x815E	R	Reserved				
0x815F	R	track id				
0x8160	R	point 2 x coordinate (low byte)				
0x8161	R	point 2 x coordinate (high byte)				
0x8162	R	point 2 y coordinate (low byte)				
0x8163	R	point 2 y coordinate (high byte)				
0x8164	R	point 2 size (low byte)				
0x8165	R	point 2 size (high byte)				
0x8166	R	Reserved				
0x8167	R	track id				
0x8168	R	point 3 x coordinate (low byte)				
0x8169	R	point 3 x coordinate (high byte)				
0x816A	R	point 3 y coordinate (low byte)				
0x816B	R	point 3 y coordinate (high byte)				
0x816C	R	point 3 size (low byte)				
0x816D	R	point 3 size (high byte)				
0x816F	R	track id				
0x8170	R	point 4 x coordinate (low byte)				
0x8171	R	point 4 x coordinate (high byte)				
0x8172	R	point 4 y coordinate (low byte)				

0x8173	R	point 4 y coordinate (high byte)
0x8174	R	point 4 size (low byte)
0x8175	R	point 4 size (high byte)
0x8176	R	Reserved
0x8177	R	track id
0x8178	R	point 5 x coordinate (low byte)
0x8179	R	point 5 x coordinate (high byte)
0x817A	R	point 5 y coordinate (low byte)
0x817B	R	point 5 y coordinate (high byte)
0x817C	R	point 5 size (low byte)
0x817D	R	point 5 size (high byte)
0x817E	R	Reserved
0x817F	R	track id
0x8180	R	point 6 x coordinate (low byte)
0x8181	R	point 6 x coordinate (high byte)
0x8182	R	point 6 y coordinate (low byte)
0x8183	R	point 6 y coordinate (high byte)
0x8184	R	point 6 size (low byte)
0x8185	R	point 6 size (high byte)
0x8186	R	Reserved
0x8187	R	track id
0x8188	R	point 7 x coordinate (low byte)
0x8189	R	point 7 x coordinate (high byte)
0x818A	R	point 7 y coordinate (low byte)
0x818B	R	point 7 y coordinate (high byte)
0x818C	R	point 7 size (low byte)
0x818D	R	point 7 size (high byte)
0x818E	R	Reserved
0x818F	R	track id
0x8190	R	point 8 x coordinate (low byte)
0x8191	R	point 8 x coordinate (high byte)
0x8192	R	point 8 y coordinate (low byte)
0x8193	R	point 8 y coordinate (high byte)
0x8194	R	point 8 size (low byte)
0x8195	R	point 8 size (high byte)
0x8196	R	Reserved
0x8197	R	track id
0x8198	R	point 9 x coordinate (low byte)
0x8199	R	point 9 x coordinate (high byte)
0x819A	R	point 9 y coordinate (low byte)
0x819B	R	point 9 y coordinate (high byte)

0x819C	R	point 9 size (low byte)
0x819D	R	point 9 size (high byte)
0x819E	R	Reserved
0x819F	R	track id
0x81A0	R	point 10 x coordinate (low byte)
0x81A1	R	point 10 x coordinate (high byte)
0x81A2	R	point 10 y coordinate (low byte)
0x81A3	R	point 10 y coordinate (high byte)
0x81A4	R	point 10 size (low byte)
0x81A5	R	point 10 size (high byte)
0x81A6	R	Reserved
0x81A7	R	KeyValue

### 12.3. I2C protocol

3.3V ,400BPS ,pull high 2K ohm

Parameter	Symbol	Min.	Max.	Unit
SCL low period	$t_{lo}$	0.9	-	us
SCL high period	$t_{hi}$	0.8	-	us
SCL setup time for START condition	$t_{st1}$	0.4	-	us
SCL setup time for STOP condition	$t_{st3}$	0.4	-	us
SCL hold time for START condition	$t_{hd1}$	0.3	-	us
SDA setup time	$t_{st2}$	0.4	-	us
SDA hold time	$t_{hd2}$	0.4	-	us

# 13. Contour Drawing

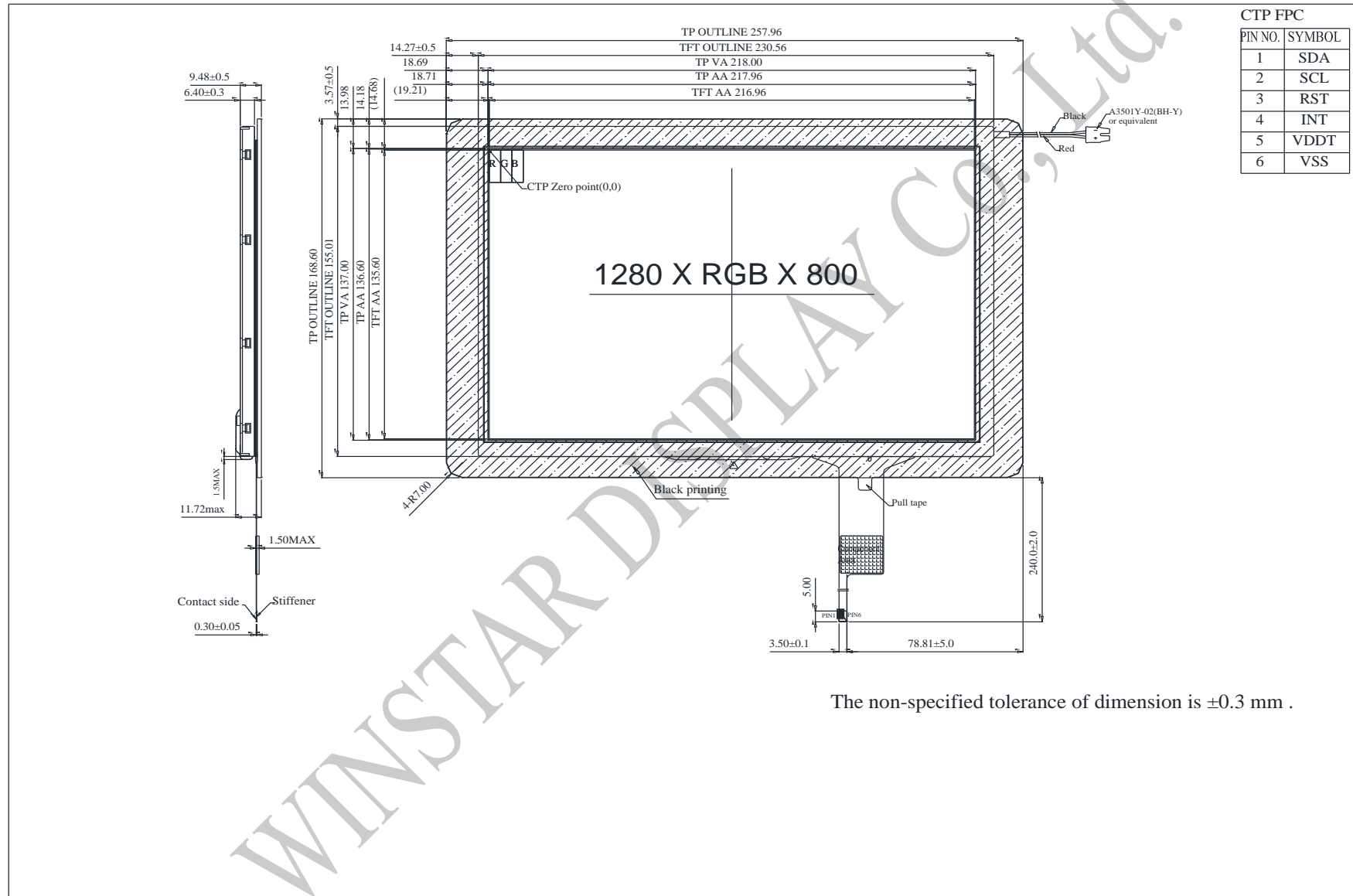

The non-specified tolerance of dimension is  $\pm 0.3$  mm .

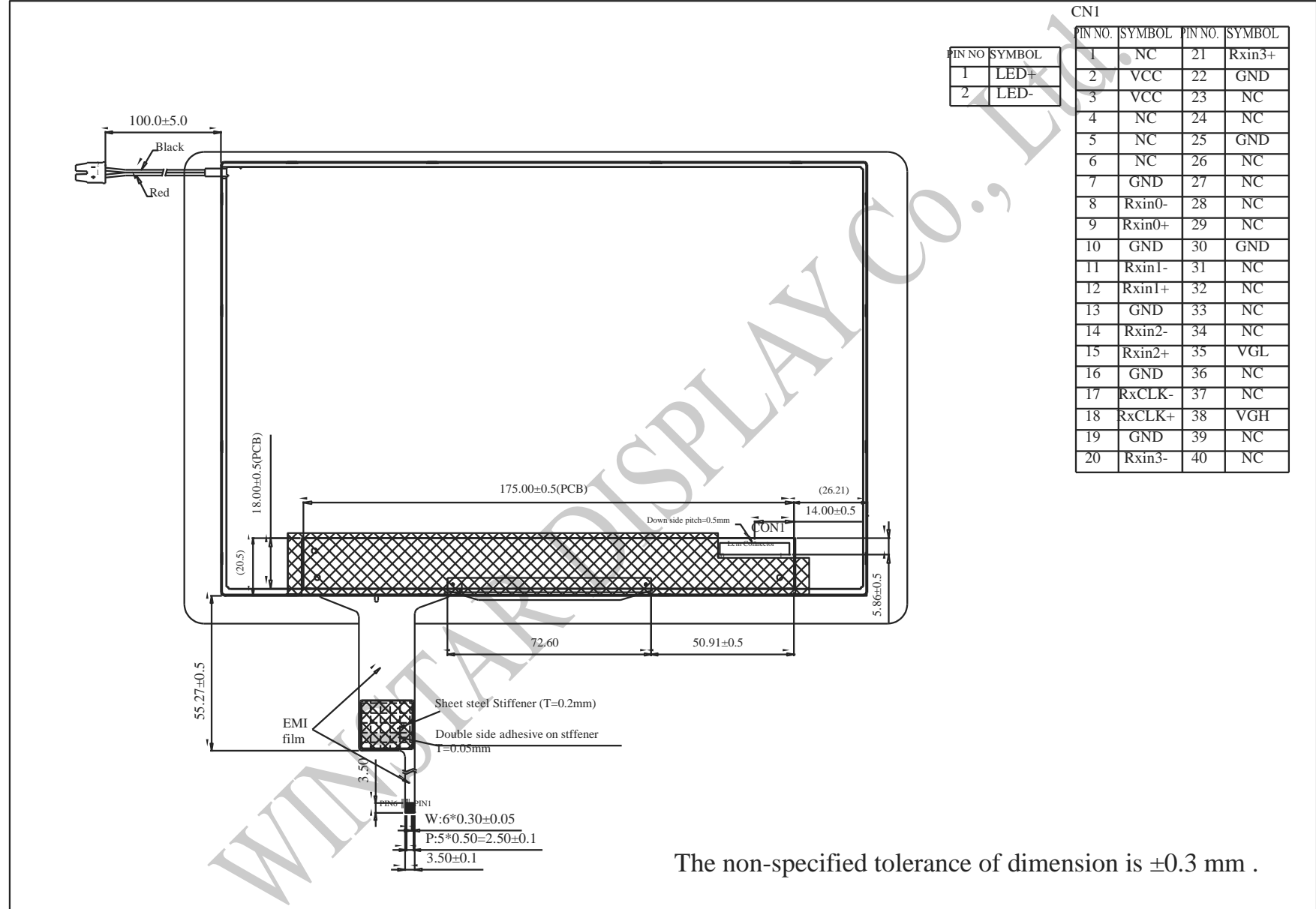



**1、Panel Specification :**

- 1. Panel Type :  Pass  NG , \_\_\_\_\_
- 2. View Direction :  Pass  NG , \_\_\_\_\_
- 3. Numbers of Dots :  Pass  NG , \_\_\_\_\_
- 4. View Area :  Pass  NG , \_\_\_\_\_
- 5. Active Area :  Pass  NG , \_\_\_\_\_
- 6. Operating :  Pass  NG , \_\_\_\_\_
- 7. Storage Temperature :  Pass  NG , \_\_\_\_\_
- 8. Others : \_\_\_\_\_

**2、Mechanical**

- 1. PCB Size :  Pass  NG , \_\_\_\_\_
- 2. Frame Size :  Pass  NG , \_\_\_\_\_
- 3. Material of Frame :  Pass  NG , \_\_\_\_\_
- 4. Connector Position :  Pass  NG , \_\_\_\_\_
- 5. Fix Hole Position :  Pass  NG , \_\_\_\_\_
- 6. Backlight Position :  Pass  NG , \_\_\_\_\_
- 7. Thickness of PCB :  Pass  NG , \_\_\_\_\_
- 8. Height of Frame to PCB :  Pass  NG , \_\_\_\_\_
- 9. Height of Module :  Pass  NG , \_\_\_\_\_
- 10. Others :  Pass  NG , \_\_\_\_\_

**3、Relative Hole Size :**

- 1. Pitch of Connector :  Pass  NG , \_\_\_\_\_
- 2. Hole size of Connector :  Pass  NG , \_\_\_\_\_
- 3. Mounting Hole size :  Pass  NG , \_\_\_\_\_
- 4. Mounting Hole Type :  Pass  NG , \_\_\_\_\_
- 5. Others :  Pass  NG , \_\_\_\_\_

**4、Backlight Specification :**

- 1. B/L Type :  Pass  NG , \_\_\_\_\_
- 2. B/L Color :  Pass  NG , \_\_\_\_\_
- 3. B/L Driving Voltage (Reference for LED) :  Pass  NG , \_\_\_\_\_
- 4. B/L Driving Current :  Pass  NG , \_\_\_\_\_
- 5. Brightness of B/L :  Pass  NG , \_\_\_\_\_
- 6. B/L Solder Method :  Pass  NG , \_\_\_\_\_
- 7. Others :  Pass  NG , \_\_\_\_\_



Winstar Module Number : \_\_\_\_\_

Page: 2

**5、Electronic Characteristics of Module :**

- 1. Input Voltage :  Pass  NG , \_\_\_\_\_
- 2. Supply Current :  Pass  NG , \_\_\_\_\_
- 3. Driving Voltage for LCD :  Pass  NG , \_\_\_\_\_
- 4. Contrast for LCD :  Pass  NG , \_\_\_\_\_
- 5. B/L Driving Method :  Pass  NG , \_\_\_\_\_
- 6. Negative Voltage Output :  Pass  NG , \_\_\_\_\_
- 7. Interface Function :  Pass  NG , \_\_\_\_\_
- 8. LCD Uniformity :  Pass  NG , \_\_\_\_\_
- 9. ESD test :  Pass  NG , \_\_\_\_\_
- 10. Others :  Pass  NG , \_\_\_\_\_

**6、Summary :**

Sales signature : \_\_\_\_\_

Customer Signature : \_\_\_\_\_

Date :     /     /     \_\_\_\_\_

