

6

5

4

3

2

1

MATERIAL AND FINISH

Insulator: Polycarbonate, UL-94V-0 rated  
Contacts: Brass, Nickel plated

ELECTRICAL SPECIFICATIONS:

Current rating: 10 A

Voltage rating: 250 VAC

Current rating: 15 A

Voltage rating: 250 VAC

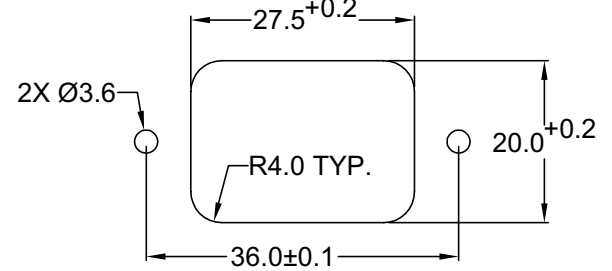
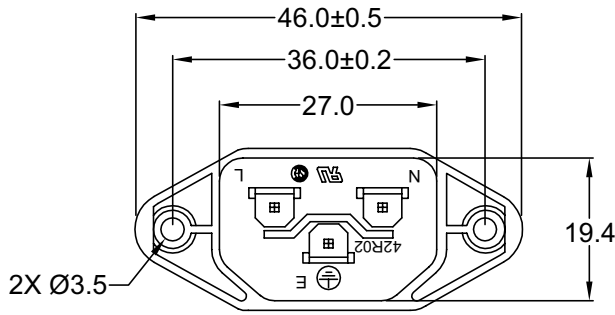

RECOMMENDED  
PANEL CUTOUT

ORDERING CODE:

42R02-1 1 2 3

1 = TERMINAL OPTIONS

1 = .187(4.8)

2 = .250(6.3)

2 = COLOR

1 = BLACK

2 = GRAY

3 = ELECTRICAL CIRCUIT  
CONFIGURATION

1 = 15A 250V 120°C  
2+GROUND



2 = 15A 250V 70°C  
2+GROUND



4 = 15A 250V 70°C  
2 POLE

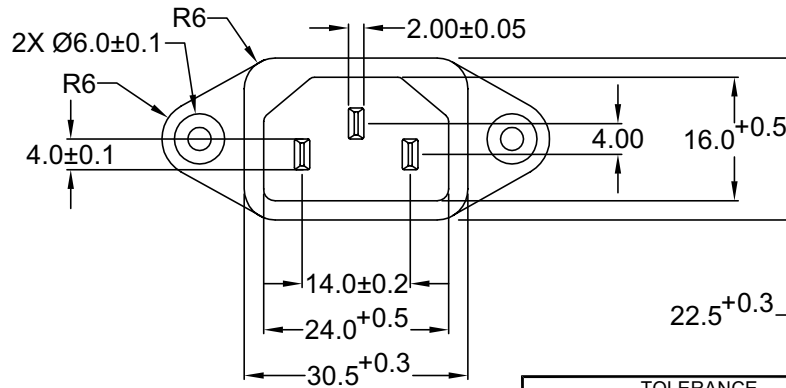
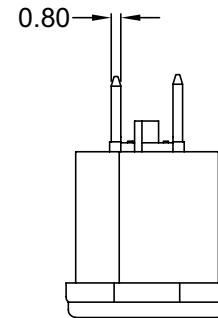
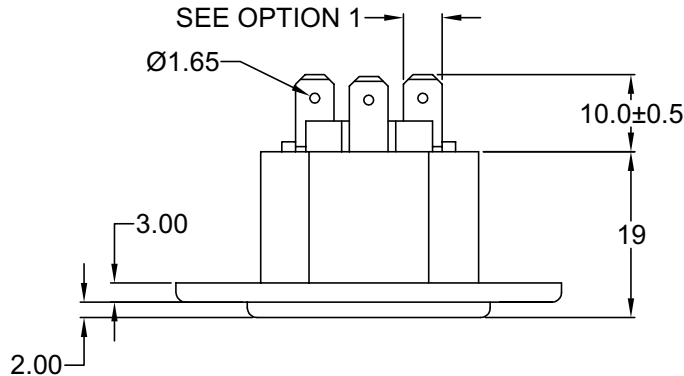

TOLERANCE UNLESS OTHERWISE SPECIFIED	
X	± 1
X.X	± 0.4
X.XX	± 0.20
DRAWN BY	GQ
CHECK BY	TD
APPR BY	PB
DATE:	8/3/01
DATE:	8/13/01
DATE:	8/13/01

**Power Dynamics, Inc.**  
 Phone: 973 560-0019 Whippany, New Jersey Fax: 973 560-0070

PART: IEC 60320 C14 APPL. INLET; QUICK CONNECT  
 TERMINALS; SIDE FLANGED, PANEL MOUNT

**42R02-1XXX**

SIZE: A SCALE: NTS

ALL DIMENSIONS FOR REFERENCE ONLY  
 DIMENSIONS ARE IN MILLIMETERS

SHEET 1 of 1

D

C

B

A

REVISIONS	CHNG	CHECK	APPR
	CHANGE		
	DATE		
	REV		

6

5

4

3

2

1

6

5

4

3

2

1

MATERIAL AND FINISH

Insulator: Polycarbonate, UL-94V-0 rated  
Contacts: Brass, Nickel plated

ELECTRICAL SPECIFICATIONS:

Current rating: 10 A  
Voltage rating: 250 VAC  
Current rating: 15 A  
Voltage rating: 250 VAC

ORDERING CODE:

42R02-2       
          1 2 3



1 = TERMINAL OPTIONS

- 1 = .187(4.8)
- 2 = .250(6.3)

2 = COLOR

- 1 = BLACK
- 2 = GRAY

3 = ELECTRICAL CIRCUIT CONFIGURATION

- 1 = 15A 250V 120°C 2+GROUND 
- 2 = 15A 250V 70°C 2+GROUND 
- 4 = 15A 250V 70°C 2 POLE 

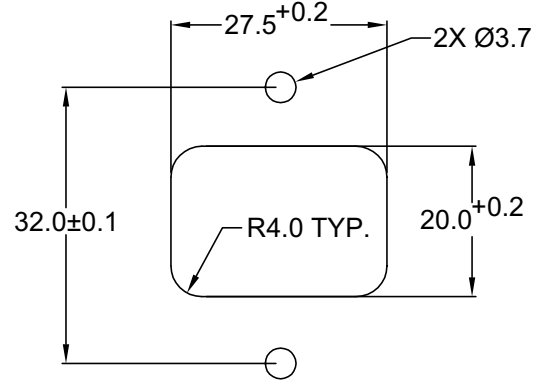
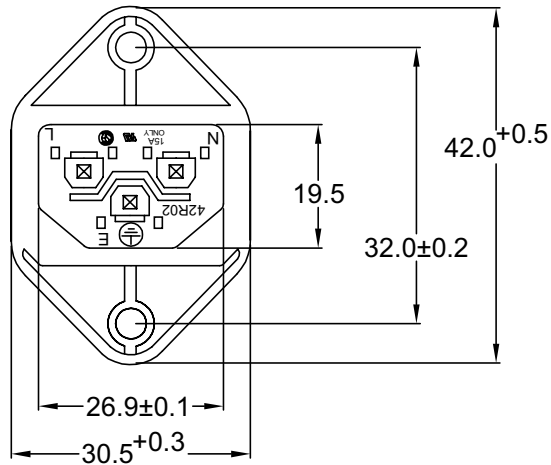

RECOMMENDED  
PANEL CUTOUT

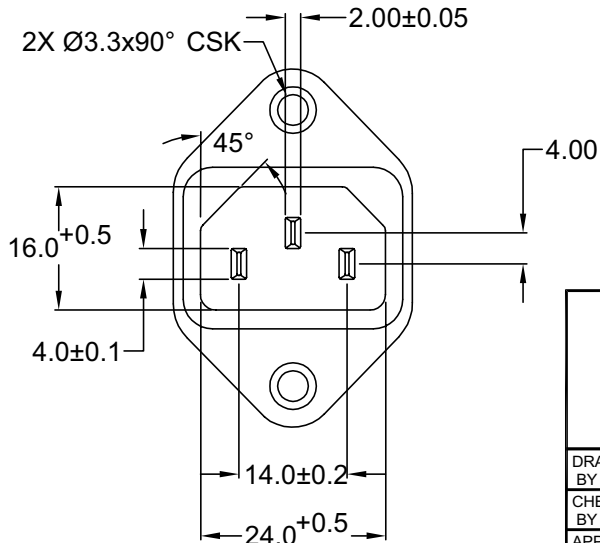
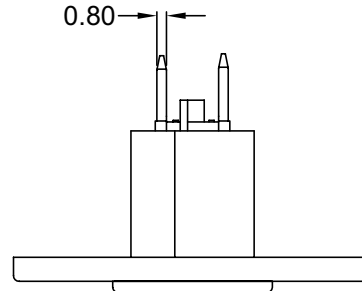
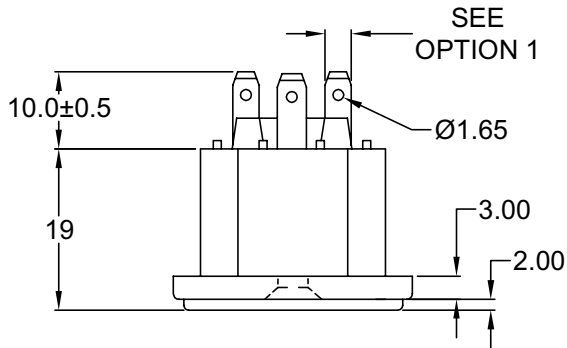

TOLERANCE UNLESS OTHERWISE SPECIFIED			
X	± 1		
X.X	± 0.4		
X.XX	± 0.20		
DRAWN BY	GQ	DATE:	8/3/01
CHECK BY	TD	DATE:	8/13/01
APPR BY	PB	DATE:	8/13/01

**Power Dynamics, Inc.**

Phone: 973 560-0019 Whippany, New Jersey Fax: 973 560-0076

PART: IEC 60320 C14 APPL. INLET; QUICK CONNECT  
TERMINALS; CROSS FLANGE

PART #: 42R02-2XXX		SHEET 1 of 1
SIZE: A	ALL DIMENSIONS FOR REFERENCE ONLY DIMENSIONS ARE IN MILLIMETERS	
SCALE: NTS	REV:	

D

C

B

A

REV	DATE	CHANGE	CHNG	CHECK	APPR

6

5

4

3



2

1

**MATERIAL AND FINISH**

Insulator: Polycarbonate, UL-94V-0 rated  
 Contacts: Brass, Nickel plated

**ELECTRICAL SPECIFICATIONS:**

Current rating: 10 A  
 Voltage rating: 250 VAC   
 Current rating: 15 A   
 Voltage rating: 250 VAC 

**ORDERING CODE:**

42R02-3        -         
           1 2 3       4



**1 = TERMINAL OPTIONS**

- 1 = .187(4.8)
- 2 = .250(6.3)

**2 = COLOR**

- 1 = BLACK
- 2 = GRAY

**3 = ELECTRICAL CIRCUIT CONFIGURATION**

- 1 = 15A 250V 120°C 2+GROUND 
- 2 = 15A 250V 70°C 2+GROUND 
- 4 = 15A 250V 70°C 2 POLE 

**4 = PANEL THICKNESS**

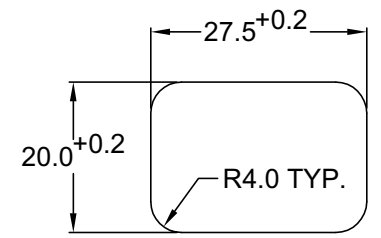
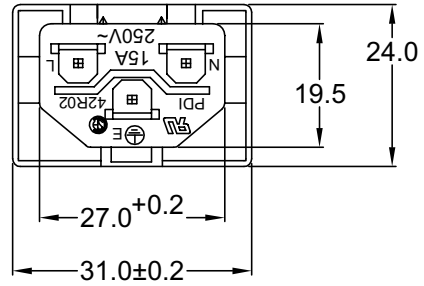

**RECOMMENDED PANEL CUTOUT**

SEE OPTION 1

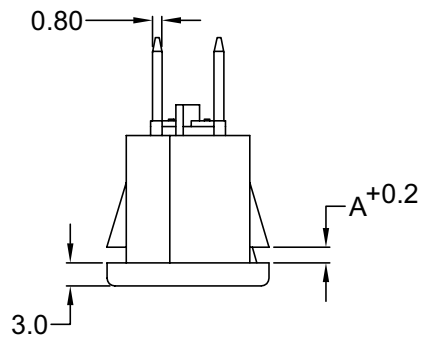
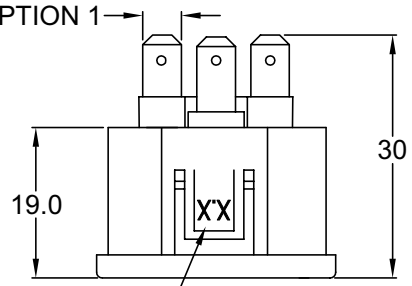

REPLACE WITH CORRESPONDING PANEL THICKNESS

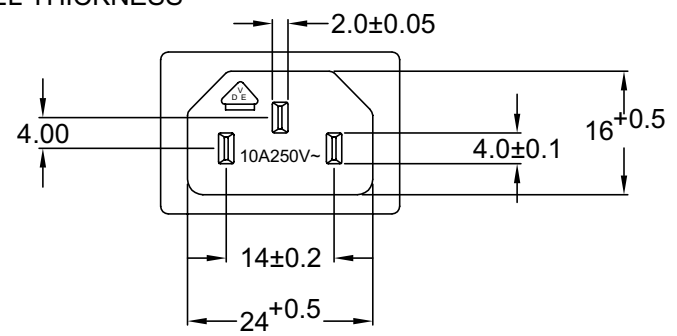

P/N	A	MAX. PANEL THICKNESS
42R02-3XXX-150	1.5	1.5
42R02-3XXX-200	2.0	2.0
42R02-3XXX-250	2.5	2.5

ADDITIONAL PANEL THICKNESS AVAILABLE ON REQUEST

TOLERANCE UNLESS OTHERWISE SPECIFIED	
X	± 1
X.X	± 0.4
X.XX	± 0.20
DRAWN BY	GQ
CHECK BY	TD
APPR BY	PB
DATE:	8/2/01
DATE:	08/14/01
DATE:	08/14/01

**Power Dynamics, Inc.**  
 Phone: 973 560-0019 Whippany, New Jersey Fax: 973 560-0076

PART: IEC 60320 CONNECTOR; QUICK CONNECT INLET; SNAP-IN

PART #: <b>42R02-3XXX-XXX</b>		SHEET 1 of 1
SIZE: A	SCALE: NTS	ALL DIMENSIONS FOR REFERENCE ONLY DIMENSIONS ARE IN MILLIMETERS
REV:		

REVISIONS	CHANGE	CHKG	CHKR	APPR
	REV	DATE		

6

5

4

3

2

1

### MATERIAL AND FINISH

Insulator: Polycarbonate, UL-94V-0 rated  
Contacts: Brass, Nickel plated

### ELECTRICAL SPECIFICATIONS:

Current rating: 10 A

Voltage rating: 250 VAC



Current rating: 15 A

Voltage rating: 250 VAC



### ORDERING CODE:

42R02-4  
1 2 3

### 1 = TERMINAL OPTIONS

1 = .187(4.8)

2 = .250(6.3)

### 2 = COLOR

1 = BLACK

2 = GRAY

### 3 = ELECTRICAL CIRCUIT CONFIGURATION

1 = 15A 250V 120°C

2+GROUND



2 = 15A 250V 70°C

2+GROUND



4 = 15A 250V 70°C

2 POLE

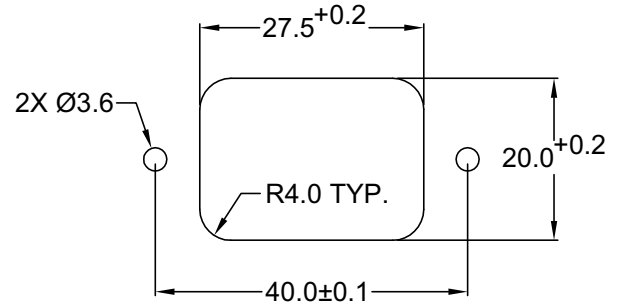
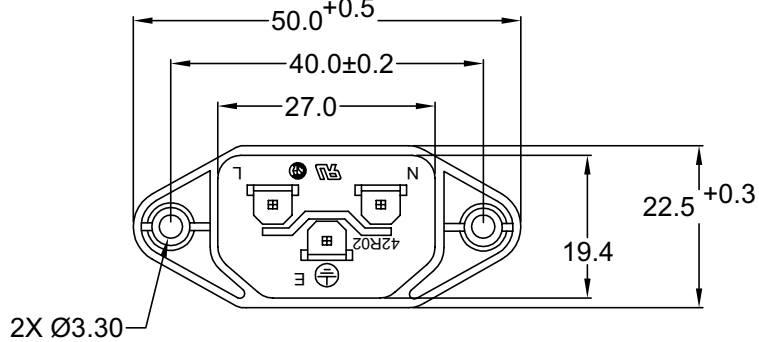

RECOMMENDED  
PANEL CUT-OUT

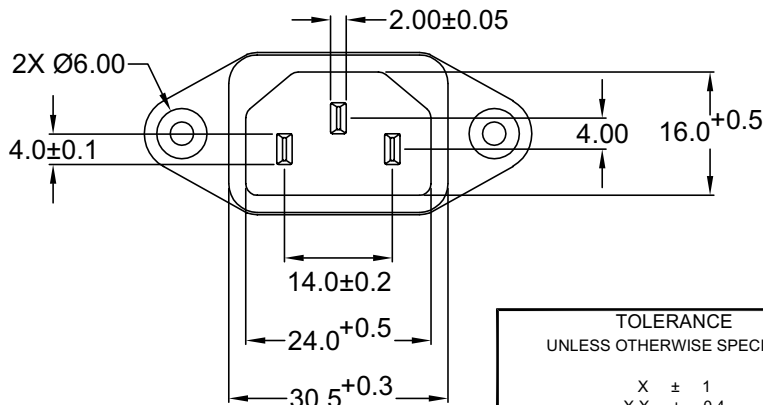
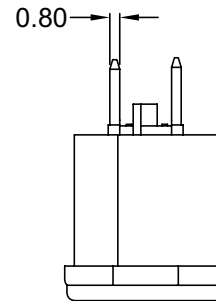
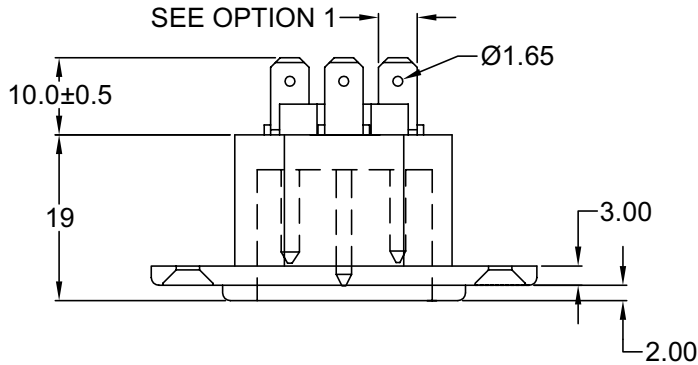

REVISIONS	CHNG	CHECK	APPR
	DATE	CHANGE	

TOLERANCE UNLESS OTHERWISE SPECIFIED		
X	±	1
X.X	±	0.4
X.XX	±	0.20
DRAWN BY	GQ	DATE: 8/6/01
CHECK BY	TD	DATE: 8/13/01
APPR BY	PB	DATE: 8/13/01

**Power Dynamics, Inc.**

Phone: 973 560-0019 Whippany, New Jersey Fax: 973 560-0076

PART: IEC 60320 C14 APPL. INLET; QUICK CONNECT  
TERMINALS; SIDE FLANGE, PANEL MOUNT

42R02-4XXX SHEET 1 of 1

SIZE: A ALL DIMENSIONS FOR REFERENCE ONLY  
SCALE: NTS DIMENSIONS ARE IN MILLIMETERS REV:

6

5

4

3

2

1

6

5

4

3



2

1

MATERIAL AND FINISH

Insulator: Polycarbonate, UL-94V-0 rated  
Contacts: Brass, Nickel plated

ELECTRICAL SPECIFICATIONS:

Current rating: 10 A   
Voltage rating: 250 VAC  
Current rating: 15 A   
Voltage rating: 250 VAC 

ORDERING CODE:

42R02-5       
          1 2 3

1 = TERMINAL OPTIONS

- 1 = .187(4.8)
- 2 = .250(6.3)

2 = COLOR

- 1 = BLACK
- 2 = GRAY

3 = ELECTRICAL CIRCUIT CONFIGURATION

1 = 15A 250V 120°C 2+GROUND 

2 = 15A 250V 70°C 2+GROUND 

4 = 15A 250V 70°C 2 POLE 

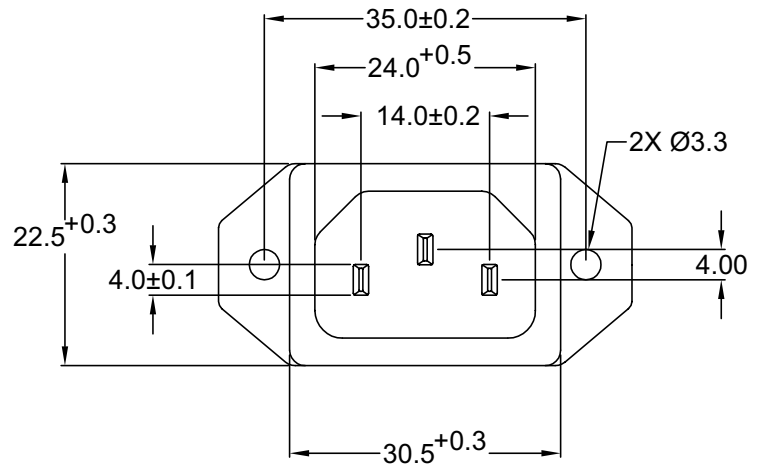
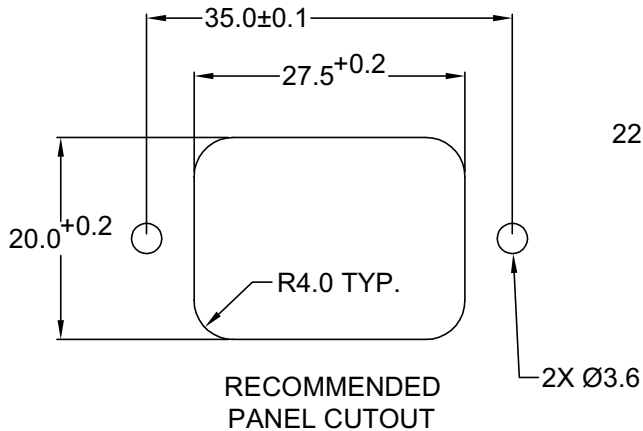
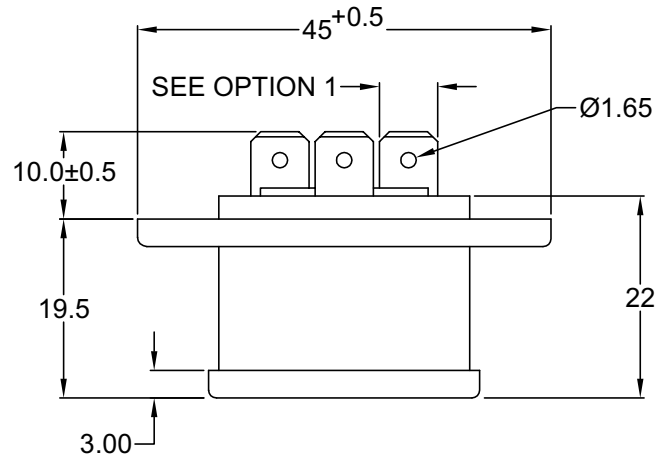
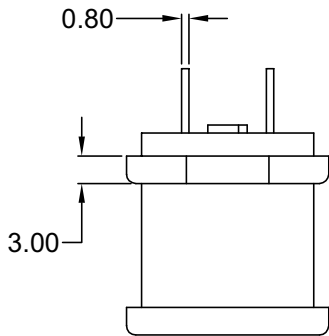

REVISIONS

REV	DATE	CHANGE	CHNG	CHK	APPR

TOLERANCE UNLESS OTHERWISE SPECIFIED		
X	±	1
X.X	±	0.4
X.XX	±	0.20

DRAWN BY	GQ	DATE:	8/9/01
CHECK BY	TD	DATE:	8/13/01
APPR BY	PB	DATE:	8/13/01

**Power Dynamics, Inc.**  
Phone: 973 560-0019 Whippany, New Jersey Fax: 973 560-0076

PART: IEC 60320 C14 APPL. INLET; QUICK CONNECT  
TERMINALS; BOTTOM FLANGE

**42R02-5XXX**

SIZE: A  
SCALE: NTS

ALL DIMENSIONS FOR REFERENCE ONLY  
DIMENSIONS ARE IN MILLIMETERS

SHEET 1 of 1  
REV:

6

5

4

3

2

1

6

5

4

3

2

1

MATERIAL AND FINISH

Insulator: Polycarbonate, UL-94V-0 rated  
Contacts: Brass, Nickel plated

ELECTRICAL SPECIFICATIONS:

Current rating: 10 A

Voltage rating: 250 VAC

Current rating: 15 A

Voltage rating: 250 VAC



ORDERING CODE:

42R02-6  
1 2 3

1 = TERMINAL OPTIONS

1 = .187(4.8)

2 = .250(6.3)

2 = COLOR

1 = BLACK

2 = GRAY

3 = ELECTRICAL CIRCUIT CONFIGURATION

1 = 15A 250V 120°C

2+GROUND



2 = 15A 250V 70°C

2+GROUND



4 = 15A 250V 70°C

2 POLE

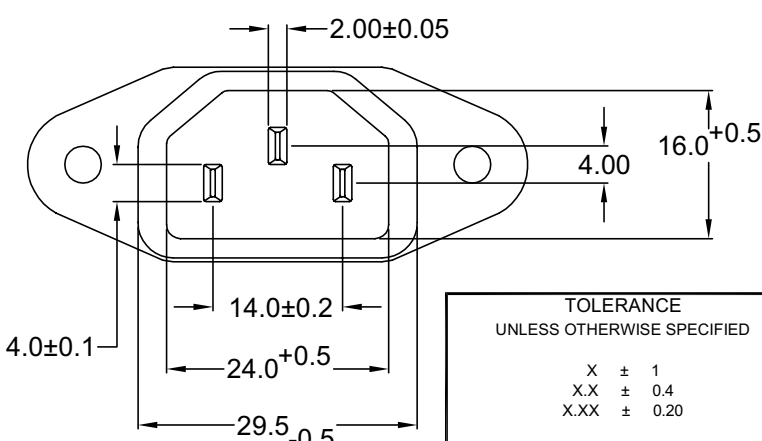
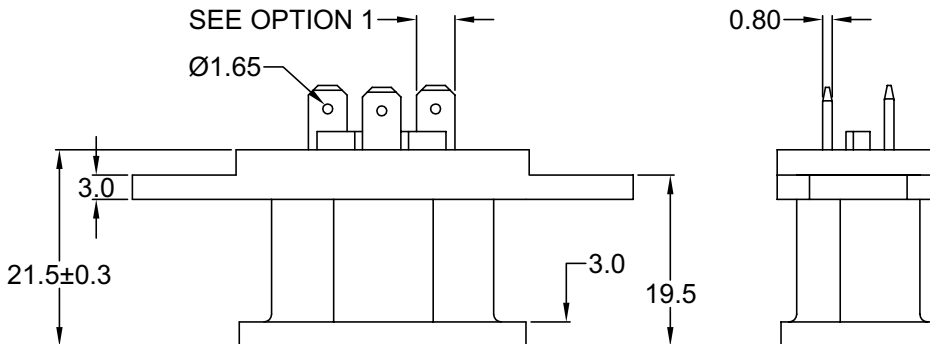
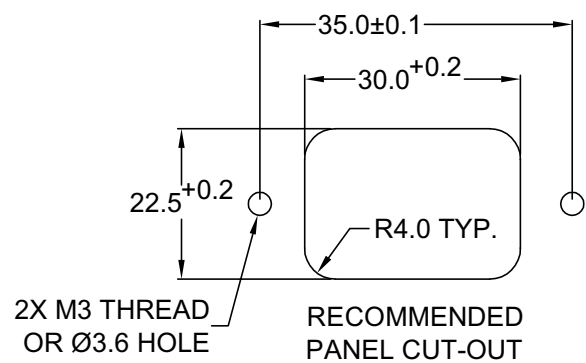
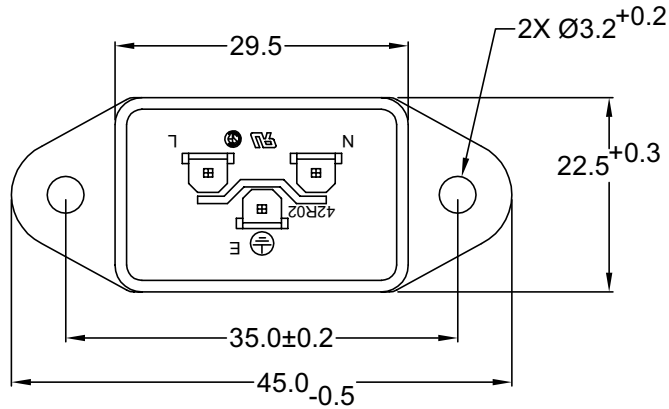

TOLERANCE  
UNLESS OTHERWISE SPECIFIED

X	± 1
X.X	± 0.4
X.XX	± 0.20

**Power Dynamics, Inc.**  
Phone: 973 560-0019 Whippany, New Jersey Fax: 973 560-0076

PART: IEC 60320 C14 APPL. INLET; QUICK CONNECT  
TERMINALS; BOTTOM FLANGE

DRAWN BY	GQ	DATE:	8/6/01
CHECK BY	TD	DATE:	8/13/01
APPR BY	PB	DATE:	8/13/01

PART #: 42R02-6XXX		SHEET 1 of 1
SIZE: A	ALL DIMENSIONS FOR REFERENCE ONLY DIMENSIONS ARE IN MILLIMETERS	REV:
SCALE: NTS		

D

C

B

A

REV	DATE	CHANGE	CHNG	CHECK	APPR

6

5

4

3

2

1

6

5

4

3

2

1

MATERIAL AND FINISH

Insulator: Polycarbonate, UL-94V-0 rated  
Contacts: Brass, Nickel plated

ELECTRICAL SPECIFICATIONS:

Current rating: 10 A

Voltage rating: 250 VAC

Current rating: 15 A

Voltage rating: 250 VAC



ORDERING CODE:

42R02-7  
1 2 3

1 = TERMINAL OPTIONS

1 = .187(4.8)

2 = .250(6.3)

2 = COLOR

1 = BLACK

2 = GRAY

3 = ELECTRICAL CIRCUIT CONFIGURATION

1 = 15A 250V 120°C  
2+GROUND



2 = 15A 250V 70°C  
2+GROUND



4 = 15A 250V 70°C  
2 POLE

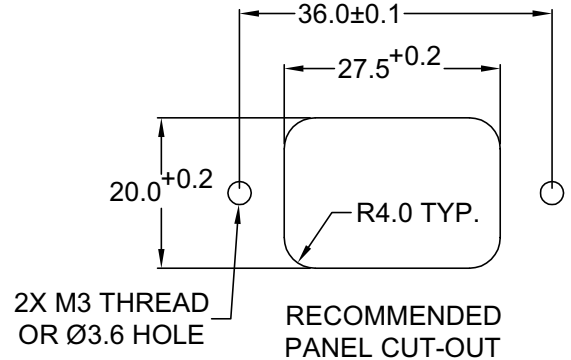
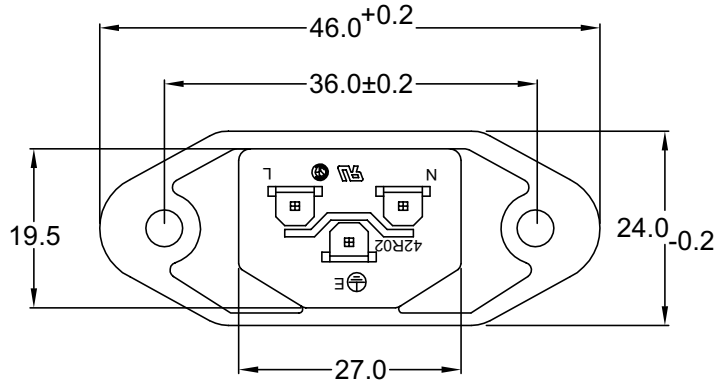

SEE OPTION 1

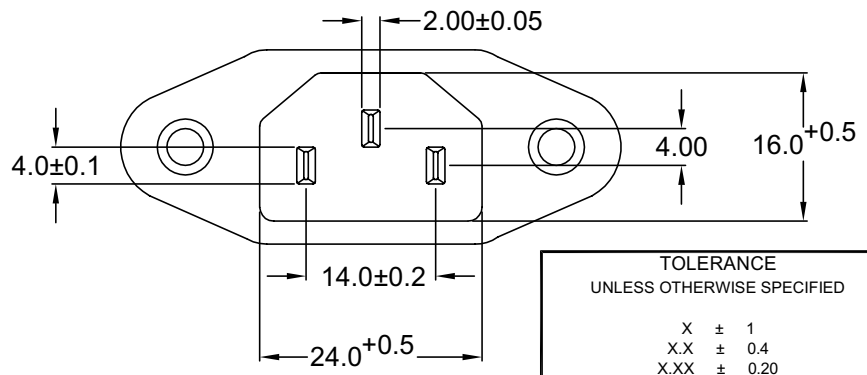
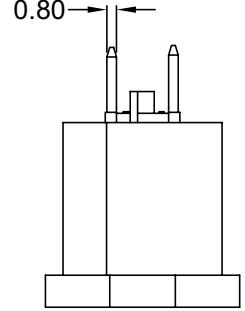
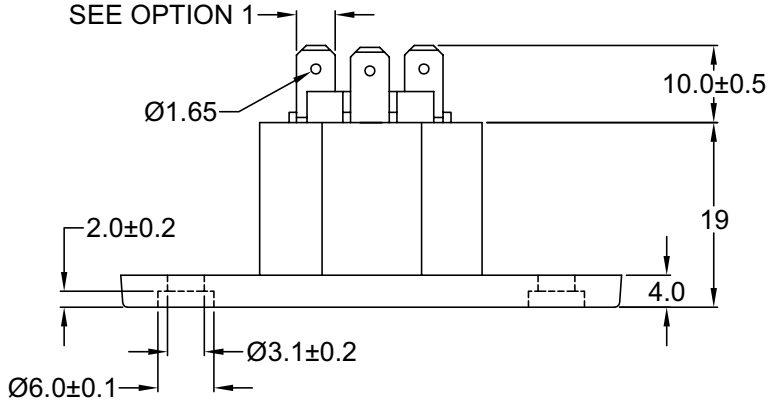

TOLERANCE  
UNLESS OTHERWISE SPECIFIED

X	± 1
X.X	± 0.4
X.XX	± 0.20

**Power Dynamics, Inc.**

Phone: 973 560-0019 Whippany, New Jersey Fax: 973 560-0076

PART: IEC 60320 C14 APPL. INLET; QUICK CONNECT  
TERMINALS; SIDE FLANGE

DRAWN BY	GQ	DATE:	08/07/01
CHECK BY	TD	DATE:	8/14/01
APPR BY	PB	DATE:	8/14/01

PART #: 42R02-7XXX		SHEET 1 of 1
SIZE: A	ALL DIMENSIONS FOR REFERENCE ONLY DIMENSIONS ARE IN MILLIMETERS	
SCALE: NTS		REV:

D

C

B

A

REV	DATE	CHANGE	CHNG	CHECK	APPR

6

5

4

3

2

1

6

5

4

3

2

1

MATERIAL AND FINISH

Insulator: Polycarbonate, UL-94V-0 rated  
Contacts: Brass, Nickel plated

ELECTRICAL SPECIFICATIONS:

Current rating: 10 A

Voltage rating: 250 VAC



Current rating: 15 A

Voltage rating: 250 VAC

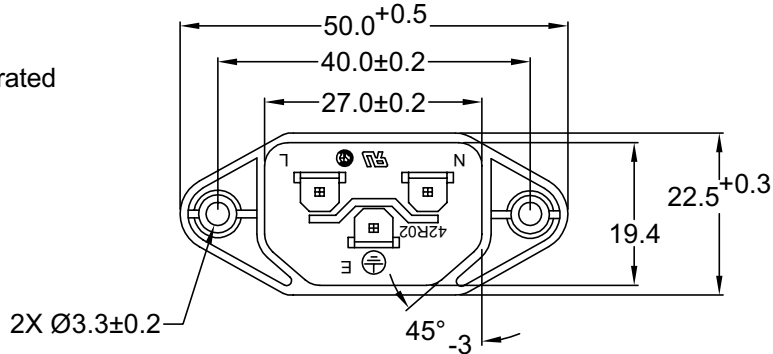

ORDERING CODE:

42R02-1 1 2 3

1 = TERMINAL OPTIONS

1 = .187(4.8)

2 = .250(6.3)

2 = COLOR

1 = BLACK

2 = GRAY

3 = ELECTRICAL CIRCUIT CONFIGURATION

1 = 15A 250V 120°C

2+GROUND



2 = 15A 250V 70°C

2+GROUND



4 = 15A 250V 70°C

2 POLE

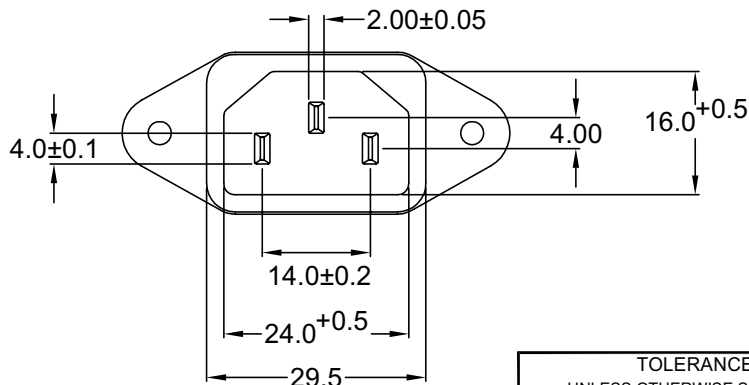
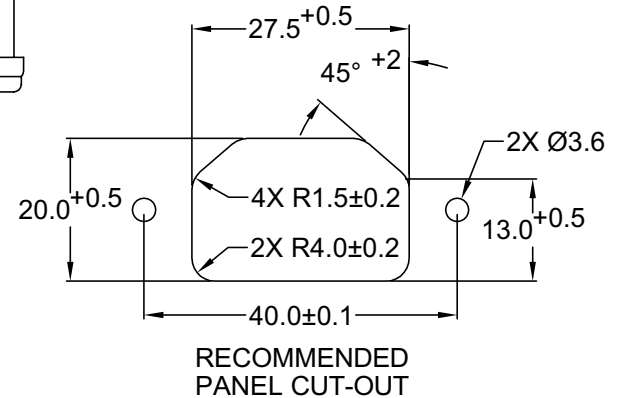
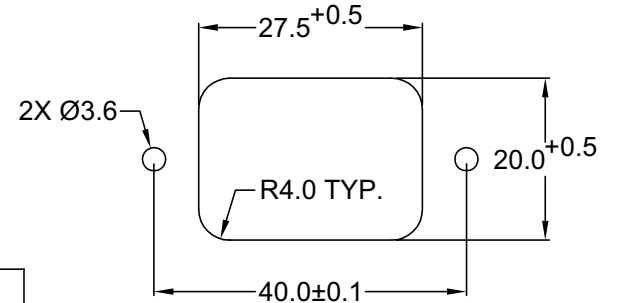
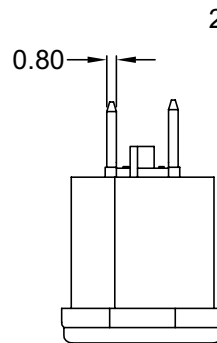
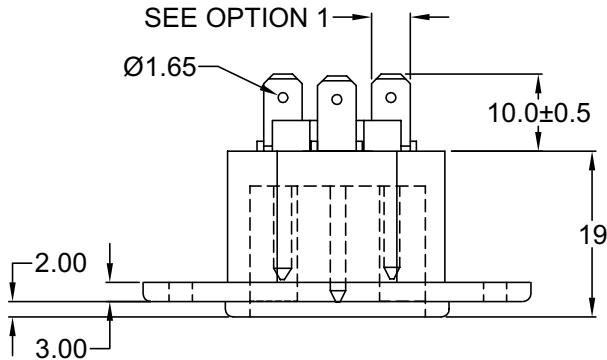

TOLERANCE UNLESS OTHERWISE SPECIFIED		
X	±	1
X.X	±	0.4
X.XX	±	0.20
DRAWN BY	GQ	DATE: 8/7/01
CHECK BY	TD	DATE: 8/13/01
APPR BY	PB	DATE: 8/13/01

**Power Dynamics, Inc.**

Phone: 973 560-0019 Whippany, New Jersey Fax: 973 560-0076

PART: IEC 60320 C14 APPL. INLET; QUICK CONNECT  
TERMINALS; SIDE FLANGE

42R02-8XXX

SHEET  
1 of 1

SIZE: A  
SCALE: NTS

ALL DIMENSIONS FOR REFERENCE ONLY  
DIMENSIONS ARE IN MILLIMETERS

REV:

D

C

B

A

REVISIONS	CHNG	CHECK	APPR
	CHANGE		
	DATE		
	REV		

6

5

4

3

2

1