

P	LTR	DESCRIPTION	DATE	DWN	APVD
	H	REVISED PER ECO-13-000728	21FEB2013	BMM	SLB

NOTES:

- MATERIAL**
 HOUSING : THERMOPLASTIC, UL94V-0, BLACK
 CONTACTS : PHOSPHOR BRONZE.
 SHELL : STEEL.
 SCREW : BRASS.
 BOARD LOCK : BRASS.
 SCREW OF TORQUE : 5 Kg-cm MAX.
- FINISH**
 CONTACT : 15µ" MIN. GOLD PLATING ON CONTACT AREA
 100µ" MIN. TIN PLATING ON SOLDERTAILS
 50µ" MIN. NICKEL UNDERPLATED OVERALL
 SHELL : 60µ" MIN. TIN PLATING
 SCREW: 50µ" MIN. NICKEL PLATING.
 BOARD LOCK : 50µ" MIN. NICKEL PLATING.
- CHARACTERISTICS**
 CURRENT RATING : 3A
 INSULATION RESISTANCE : 1000MOHMS MIN, 500VDC FOR 2MINS.
 TEMPERATURE RATING : -55DEGC ~ +105DEGC
 VOLTAGE RATING : 250VDC

⚠ OBSOLETE PARTS: OBSOLETE CIS STREAMLINING PER D.RENAUD/D.SINISI

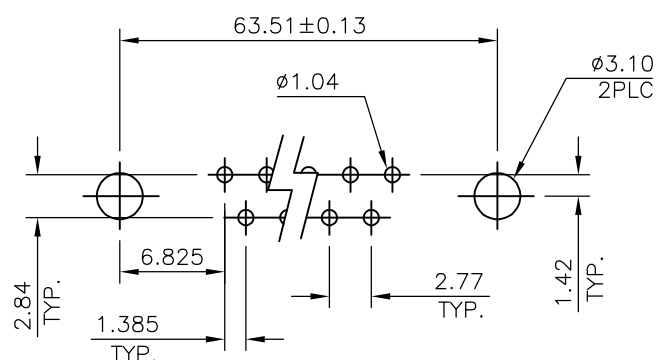
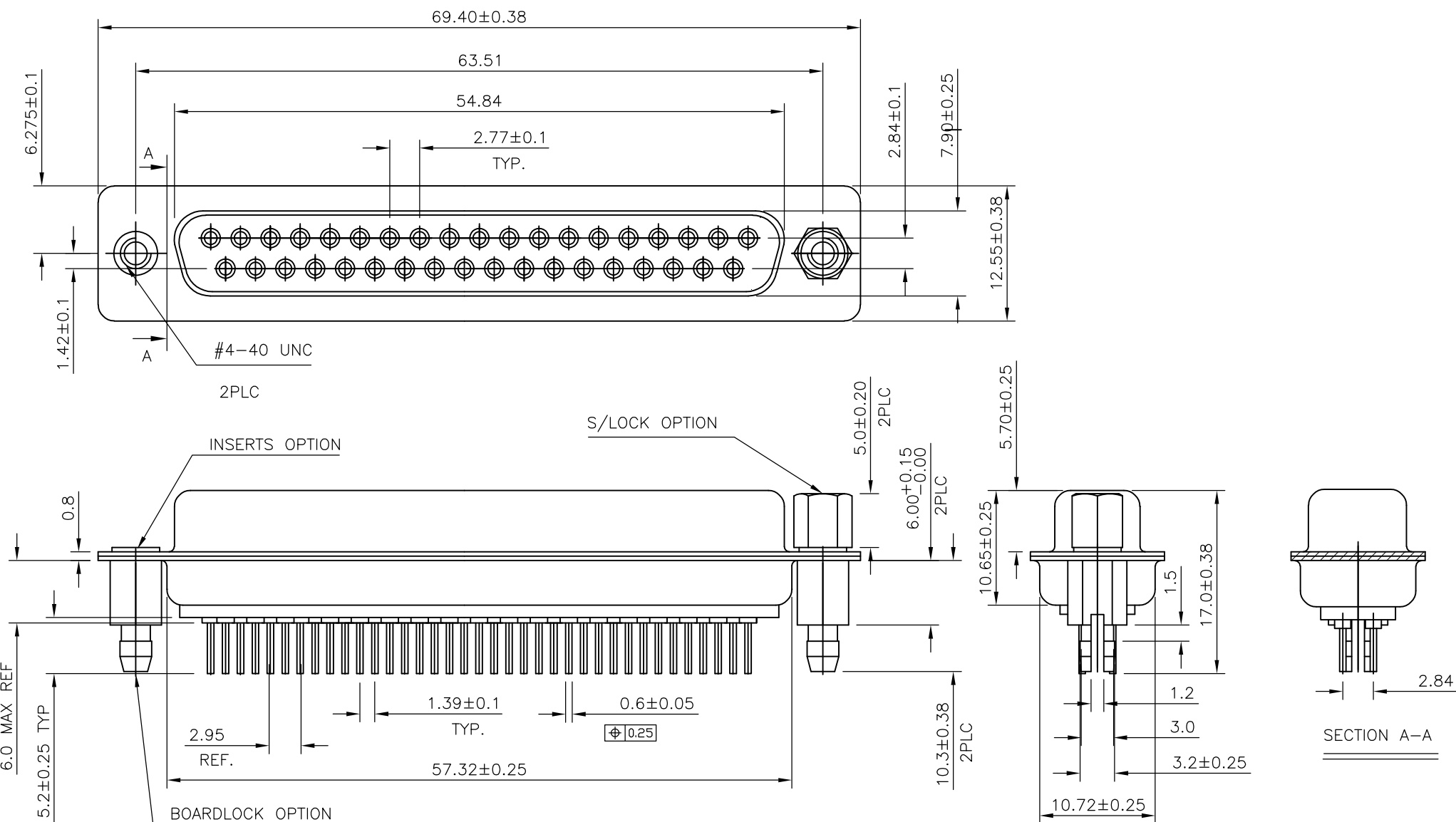

RECOMMENDED PCB LAYOUT(TOP VIEW)
(PCBTOLERANCE : ±0.05)

⚠ OBSOLETE	37W D SKT WITH B/L & M3 S/LOCK 15µ" GOLD	4-1634225-2
	37W D SKT WITH B/L & 4-40 S/LOCK 15µ" GOLD	3-1634225-2
⚠ OBSOLETE	37W D SKT WITH B/L & M3 INSERTS 15µ" GOLD	2-1634225-2
	37W D SKT WITH B/L & 4-40 INSERTS 15µ" GOLD	1-1634225-2
	DESCRIPTION	TE PART No.

THIS DRAWING IS A CONTROLLED DOCUMENT. DIMENSIONING AND TOLERANCING PER ASME Y14.5M-2009		DWN J.SANDWELL 10APR03	TE Connectivity	
DIMENSIONS: MM		CHK R.DYER 10APR03		
TOLERANCES UNLESS OTHERWISE SPECIFIED:		APVD F.WHEELER-KING 10APR03	NAME	
0 PLC ± -	1 PLC ± 0.25	PRODUCT SPEC -	D-SUB HD20, VERTICAL, 37P SKT CONNECTOR	
2 PLC ± 0.15	3 PLC ± -	APPLICATION SPEC -	SIZE	CAGE CODE
4 PLC ± -	ANGLES ± -	WEIGHT -	A3	00779
MATERIAL -	FINISH -	CUSTOMER DRAWING	DRAWING NO	RESTRICTED TO
			G-1634225	-
		SCALE 2:1	SHEET 1 OF 2	REV H

THIS DRAWING IS UNPUBLISHED.

RELEASED FOR PUBLICATION APR , 2003.

© COPYRIGHT 2003 By -

ALL RIGHTS RESERVED.

LOC	DIST	REVISIONS			
P	LTR	DESCRIPTION	DATE	DWN	APVD
GP	00	-	SEE SHEET 1	-	-

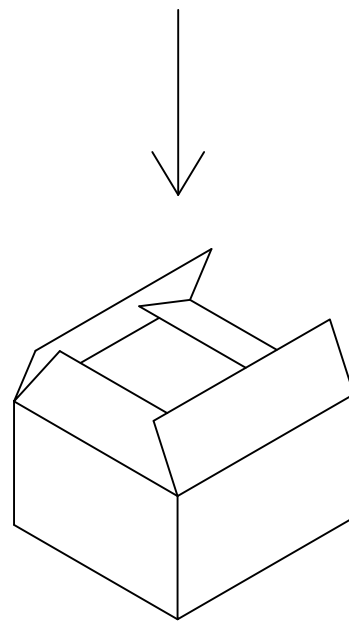
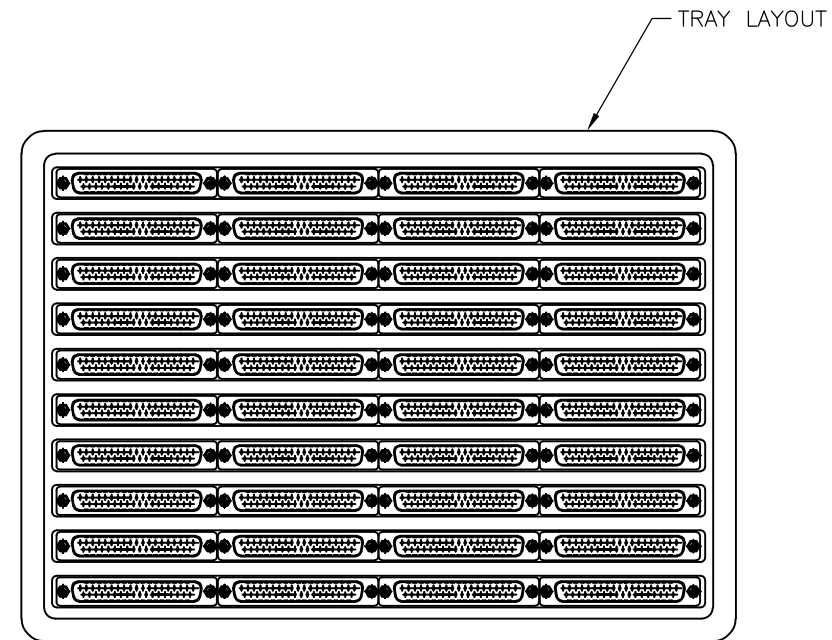
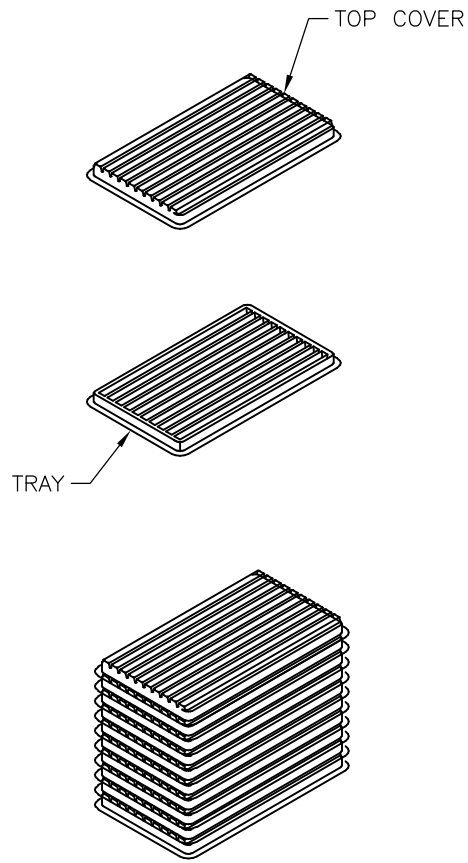

NOTES:

MATERIAL

- 1. TRAY: PVC
- 2. SHIPPING CARTON: CORRUGATED FIBERBOARD

DIMENSIONS

- 1. TRAY: L=310, W=230, H=21
- 2. SHIPPING CARTON: L=330, W=245, H=160

QUANTITY

- 40 PCS/TRAY
- 10 TRAY/SHIPPING CARTON

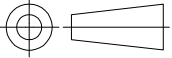
THIS DRAWING IS A CONTROLLED DOCUMENT. DIMENSIONING AND TOLERANCING PER ASME Y14.5M-2009		DWN J.SANDWELL 10APR03	 TE Connectivity		
DIMENSIONS: MM 		CHK R.DYER 10APR03			
TOLERANCES UNLESS OTHERWISE SPECIFIED: 0 PLC ± - 1 PLC ± 0.25 2 PLC ± 0.15 3 PLC ± - 4 PLC ± - ANGLES ± -		APVD F.WHEELER-KING 10APR03	D-SUB HD20, VERTICAL, 37P SKT CONNECTOR		
MATERIAL -		FINISH -	PRODUCT SPEC -	APPLICATION SPEC -	RESTRICTED TO -
CUSTOMER DRAWING			WEIGHT -	SIZE A3	CAGE CODE 00779
			DRAWING NO C-1634225		SCALE 2:1
			SHEET 2 OF 2		REV H