

未注公差/General tolerances(mm)													0.1/10 ±2'
0	>3	>6	>10	>18	>30	>50	>80	>120	>180	>250	>315	>400	
~3	~6	~10	~18	~30	~50	~80	~120	~180	~250	~315	~400	~500	
±0.12	±0.18	±0.22	±0.26	±0.31	±0.37	±0.57	±0.80	±0.93	±1.05	±1.15	±1.60	±2.20	±2.50

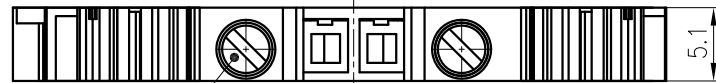

2

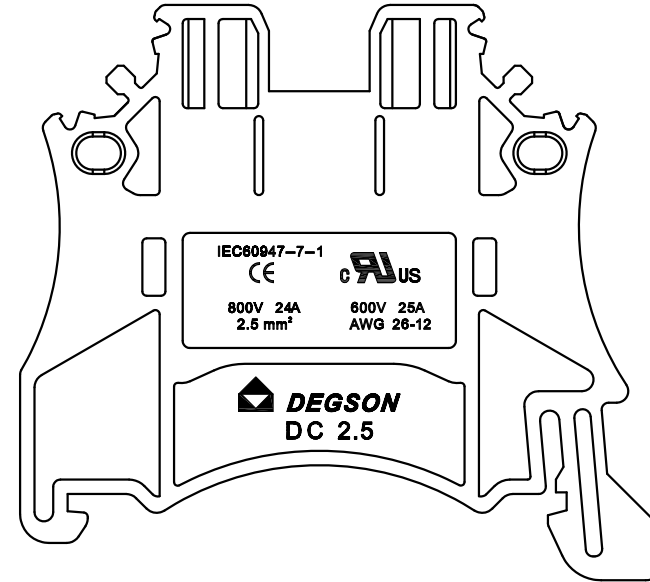
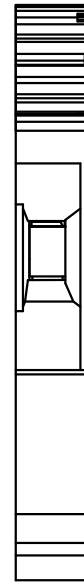
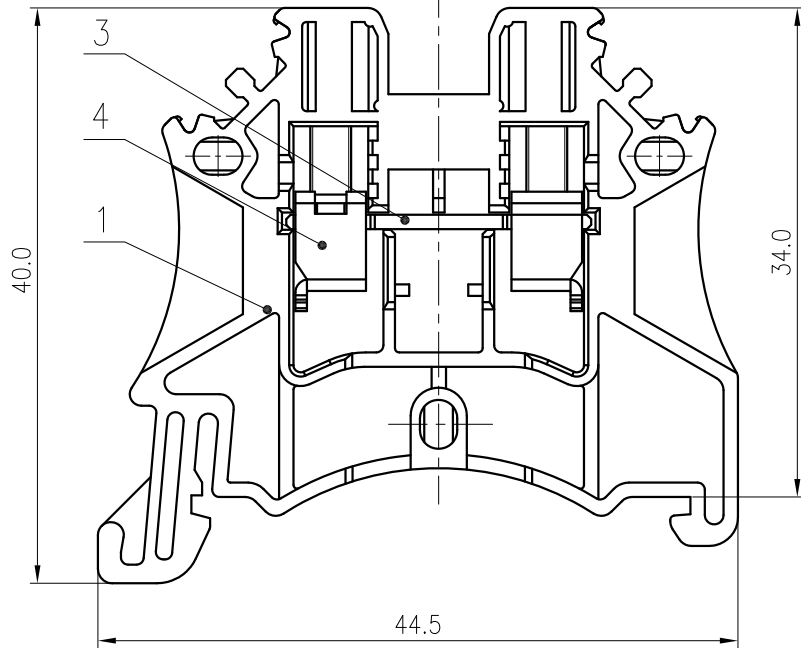

UL 标准/UL Standard:	B	C	D
额定电压/电流/Rated Voltage(V)/Current(A)	600/25	600/25	600/5
IEC 标准/IEC Standard:			
过压类别/Overvoltage Category/污染等级/Pollution Degree	III/3	III/2	II/2
额定电压/电流/Rated Voltage(V)/Current(A)	800/24	/	/
额定脉冲电压(KV)/Rate Impulse Voltage(KV)	8.0	/	/
螺丝扭矩/Torque Tightening(N·m/Lb.in)	M2.5, 0.4/3.54		
线径范围(硬线和软线)/Wire Range(rigid and flexible)(mm²/AWG)	0.2~2.5/26~12		
间距/Pitch(mm)	5.1		
剥线长度/Stripping length(mm)	8~9		
使用温度范围/Operating temperature(°C)	-40~+105		
符合RoHS环保要求/Conform to RoHS	Yes		

4	Cage	Steel	Zn Plated
3	Current Carrier	Copper	Sn Plated
2	Screw	Steel	Zn Plated
1	Housing	PA66	UL94 V-0

ITEM	NAME OF PART	MATERIAL	NOTES
1			
2			
3			
4			

REV	ECN	DESCRIPTION	DRFT	DATE

MATERIAL: /	SURFACE: /	
MAT NO.: /	宁波高松电子有限公司 NINGBO DEGSON ELECTRICAL CO., LTD	
STATUS: /		
APPD: Li GL 2020.05.27	NAME: DC2.5-01P-1Y-00A(H)	
CHKD: Mao J 2020.05.27	DRAWING NO.: DC2.5-C01	
DRFT: Ding 2015.10.24	REV	T2
SIZE: A4	TYPE: CUSTOMER DRAWING	SCALE: 2:1
	SHEET	1/1