

# Engineering Change Notice

## 產品變更通知單

ECN No. 變更單號	ECN2400001	Issue Date 發行日期	2024/02/06
Product No. 產品料號	115U-T003/115U-T005	Category 產品類別	Nano SIM Socket

Purpose 設變目的	The operating temperature has been raised from 85 degrees to 105 degrees. 操作溫度從85度提昇至105度
Suggested Equivalent Parts 建議替代料	N/A 無
Difference 差異說明	See Attachment 附件說明
Implement 導入方式	1. Immediately Change 立即導入 2. Running Change 消耗庫存導入 3. Next Lot 下批導入 4. Others 其他導入方式(請備註)
Technical Effect 技術變異	N/A 無

To each of ATTEND customers & partners,  
致 立威科技股份有限公司的客戶及合作夥伴:

The above is our Engineering Change Notification (ECN), in order to achieve excellent product management, we will from time to time through the ECN process, optimize the product design to ensure our customers obtaining high-performance product quality.

以上是我們的產品設計變更通知信函。為了達到更精良的產品管理。我們將會不定期的透過設計變更流程。進而優化產品的設計。以確保客戶能獲得高效能的產品品質。

Thanks for your cooperation in advance.  
感謝您的配合。

Fros Liao / Engineer  
ATTEND Technology Inc.  
立威科技股份有限公司

REV.	DESCRIPTION	DRAWN	DATE
1	INITIAL RELEASE	FROS	2021/12/03
2	ECR2300007	FROS	2023/11/01

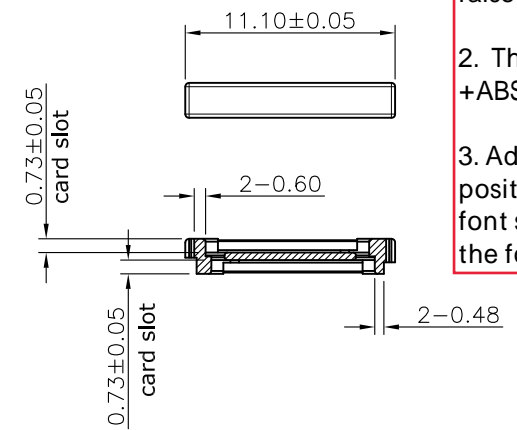
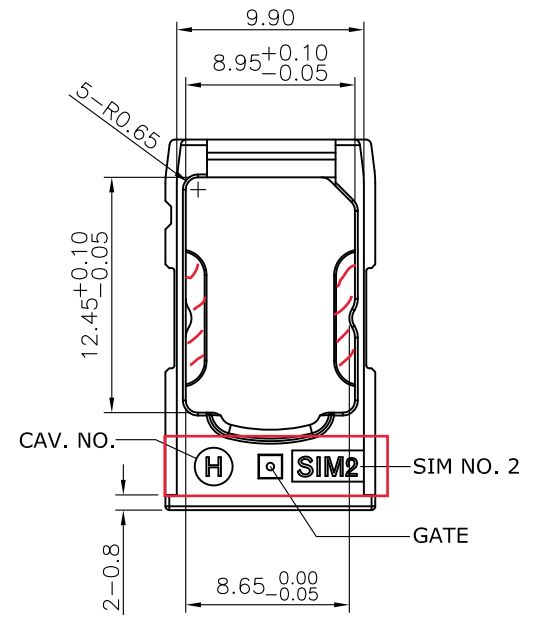
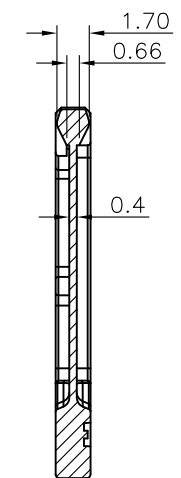
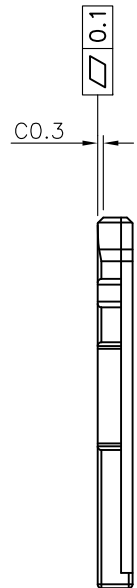
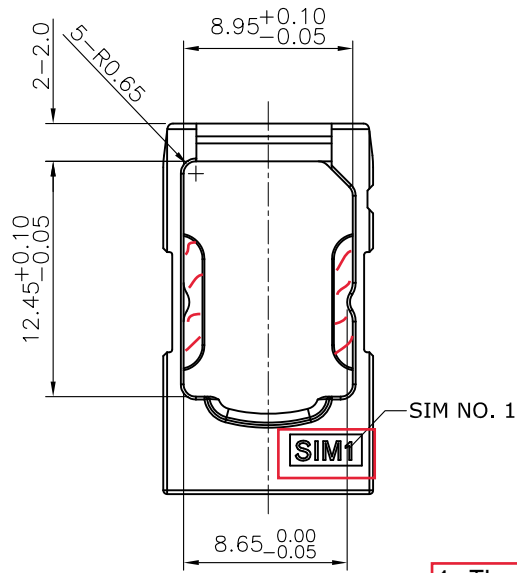
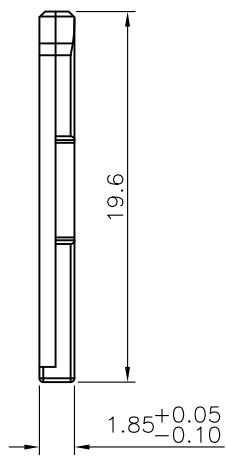
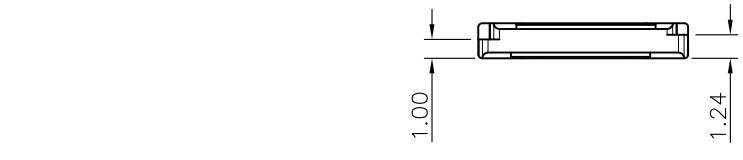

1. The operating temperature has been raised from 85 degrees to 105 degrees.
2. The material has been changed from PC +ABS to PBT
3. Added a plastic mold, changed the position of injection points, increased the font size for mold engraving, and adjusted the force for holding the card.

NOTE:  
 1. MATERIAL: PBT, UL 94V-0, Black  
 2. Operating & storage temp. range: -40°C~+105°C

UNLESS OTHERWISE SPECIFIED TOLERANCE				 www.attend.com.tw	
UNIT:	DECIMAL	LINEAR	ANGLES		
mm	X.	±0.50	±5°	DRAWN NAME: Card Tray, Used for 115U-B100, PBT, Black	
	X.X	±0.25	±3°		
	X.XX	±0.12	±1°		
DRAWN	Fros	2021/08/10	DRAWN NAME:		
CHECKED	Tim	2021/08/10	Card Tray, Used for 115U-B100, PBT, Black		
APPROVED	Ken	2021/08/10	PRODUCT NO.	115U-T003	
SCALE	SHEET	SIZE	FILE NAME	115U-T003_B_2	
2.5/1	1/1	A4			

REV.	DESCRIPTION	DRAWN	DATE
A	ENGINEERING VERSION	FROS	2023/02/02
1	INITIAL RELEASE	FROS	2023/03/10
2	ECR2300007	FROS	2023/11/01

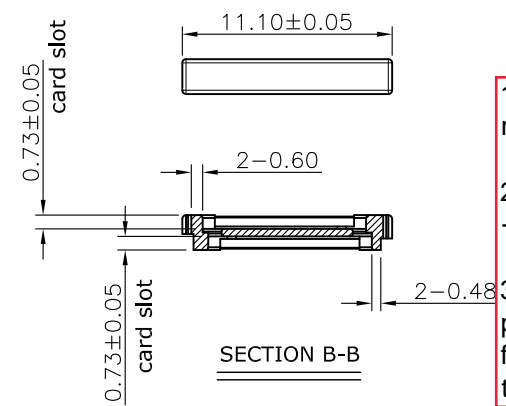
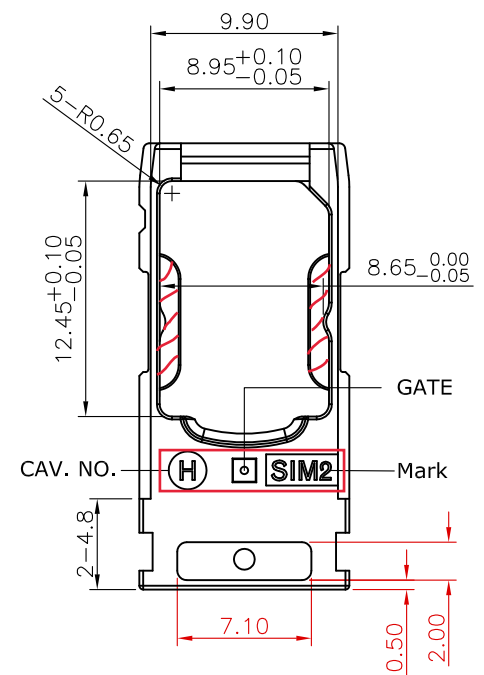
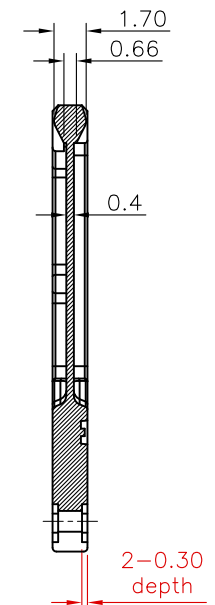
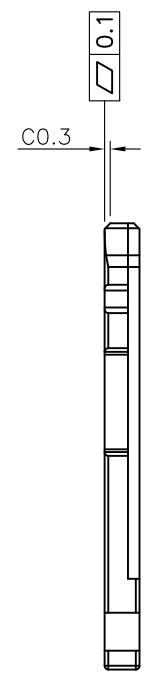
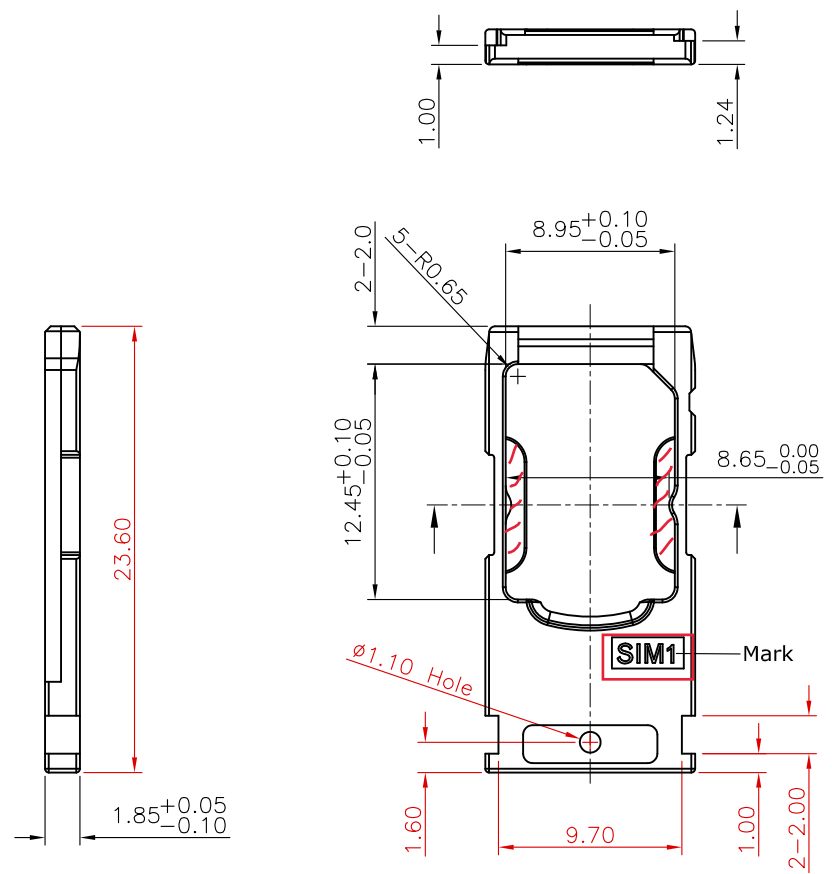

- The operating temperature has been raised from 85 degrees to 105 degrees.
- The material has been changed from PC +ABS to PBT
- Added a plastic mold, changed the position of injection points, increased the font size for mold engraving, and adjusted the force for holding the card.

NOTE:  
 1. MATERIAL: PBT, UL 94V-0, Black  
 2. Operating & storage temp. range: -40°C~+105°C

UNLESS OTHERWISE SPECIFIED TOLERANCE				 www.attend.com.tw	
UNIT:	DECIMAL	LINEAR	ANGLES		
mm	X.	±0.50	±5°	DRAWN NAME: Card Tray, Used for 115U-B100, PBT, Black, Bag, 23.6L	
	X.X	±0.25	±3°		
	X.XX	±0.12	±1°		
DRAWN	Fros	2021/08/10	DRAWN NAME:		
CHECKED	Tim	2021/08/10	Card Tray, Used for 115U-B100, PBT, Black, Bag, 23.6L		
APPROVED	Ken	2021/08/10	PRODUCT NO.	115U-T005	
SCALE	2.5/1	SHEET	1/1	SIZE	A4
FILE NAME			115U-T005_B_2		