

A 7 BAR ABSOLUTE PRESSURE SENSOR: SPD200AAT005

This 7 bar absolute pressure sensor is specially designed for measuring the pressure of liquefied gasses (like l.g.p.). Using an Absolute type pressure sensor has a distinct safety advantage over a Gauge type pressure sensor for this type of applications.

In case of a malfunction of the membrane of a Gauge type pressure sensor a gas leak could occur. Using an Absolute type pressure sensor completely circumvents this safety issue.

The trade-off is that the connecting wires carrying the electrical signals have to be run inside the pressurized container.
The TO5 metal can encapsulation is especially suited for mounting in a ruggedized brass fitting.

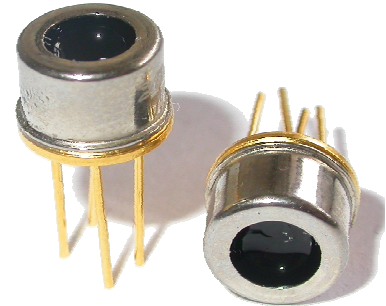

Electrical Characteristics

Characteristic @ Vcc = 5V and 25 °C

Parameter	Min	Typ	Max	Units.
Excitation Voltage	4,75	5.00	5.25	V
Excitation Current	-	2.5		mA
Pressure range	15		100	psi
Zero output (15 psi)	0.428	0.500	0.572	V
Span output		4.0		V
Accuracy			1.8	%FS
Linearity	-0,5		0,5	%FS
Thermal hysteresis	-0,15		0,15	%FS
response time		1	2	ms
Over pressure			1.2X	Rated FS
temp compensating	0		50	°C
Operating Temp	-20		100	°C
Storage temp.	-40		125	°C

- Wetted materials are: nickel, silicon, RTV, gold and glass
- Other pressure ranges on request
- Output is ratiometric to the Vcc supply voltage.

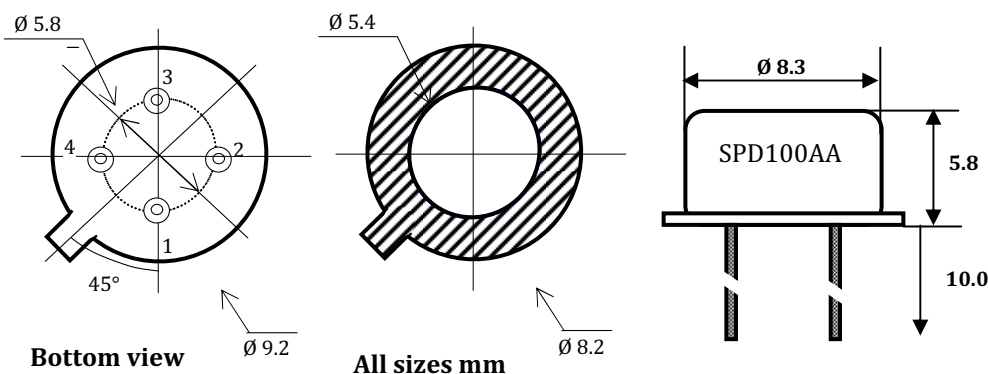

Pin Description

1	Vcc
2	Vcc
3	Gnd
4	Out

- Header must be left floating
- A 0.1 µf capacitor must be connected between Vcc and Gnd