

Introduction

The PIC16F181 microcontroller family has a suite of analog peripherals that enables precision sensor applications. This product family is available from 8 to 44-pin packages in a memory range of 7 KB to 28 KB, with speeds up to 32 MHz. This product includes a 12-bit differential Analog-to-Digital Converter with Computation (ADCC), two 8-bit Digital-to-Analog Converters (DAC), up to four 16-bit Pulse-Width Modulation (PWM) peripherals, and many more waveform control and communication peripherals. This small form factor, feature-rich device is well suited for low-cost, energy-efficient analog sensor applications with higher resolution requirements.

PIC16F181 Family Summary

Table 1. Devices Included in This Data Sheet

Device	Program Flash Memory (bytes)	Data Flash Memory (EEPROM) (bytes)	Data SRAM (bytes)	Memory Access Partition/ Device Information Area	I/O Pins ⁽¹⁾ / Peripheral Pin Select	8-Bit Timers with HLT/ 16-Bit Timers ⁽²⁾	16-Bit PWM/ CCP	12-Bit ADC Channels (External-/External-/Internal)	I ² C/SPI	EUSART	NCO	CWG	CLC	FVR	CMP	8-bit DAC	ZCD	SMBus Compatible I/O Pads	External Interrupt Pins	Interrupt-on-Change Pins	Windowed Watchdog Timer
PIC16F18126	28K	256	2048	Y/Y	12/Y	2/2	2/2	11/11/7	2/2	2	1	1	4	2	2	2	1	Y	1	12	Y
PIC16F18146	28K	256	2048	Y/Y	18/Y	2/2	2/2	17/17/7	2/2	2	1	1	4	2	2	2	1	Y	1	18	Y

Table 2. Devices Not Included in This Data Sheet

Device	Program Flash Memory (bytes)	Data Flash Memory (EEPROM) (bytes)	Data SRAM (bytes)	Memory Access Partition/ Device Information Area	I/O Pins ⁽¹⁾ / Peripheral Pin Select	8-Bit Timers with HLT/ 16-Bit Timers ⁽²⁾	16-Bit PWM/ CCP	12-Bit ADC Channels (External-/Internal)	I2C/SPI	EUSART	NCO	CWG	CLC	FVR	CMP	8-bit DAC	ZCD	SMBus Compatible I/O Pads	External Interrupt Pins	Interrupt-on-Change Pins	Watchdog Timer
PIC16F18114	7K	128	512	Y/Y	6/Y	2/2	2/2	5/5/7	2/2	2	1	1	4	2	2	2	1	Y	1	6	Y
PIC16F18115	14K	128	1024	Y/Y	6/Y	2/2	2/2	5/5/7	2/2	2	1	1	4	2	2	2	1	Y	1	6	Y
PIC16F18124	7K	128	512	Y/Y	12/Y	2/2	2/2	11/11/7	2/2	2	1	1	4	2	2	2	1	Y	1	12	Y
PIC16F18125	14K	128	1024	Y/Y	12/Y	2/2	2/2	11/11/7	2/2	2	1	1	4	2	2	2	1	Y	1	12	Y
PIC16F18144	7K	128	512	Y/Y	18/Y	2/2	2/2	17/17/7	2/2	2	1	1	4	2	2	2	1	Y	1	18	Y
PIC16F18145	14K	128	1024	Y/Y	18/Y	2/2	2/2	17/17/7	2/2	2	1	1	4	2	2	2	1	Y	1	18	Y
PIC16F18154	7K	128	512	Y/Y	25/Y	3/2	4/2	24/11/7	2/2	2	1	1	4	2	2	2	1	Y	1	25	Y
PIC16F18155	14K	128	1024	Y/Y	25/Y	3/2	4/2	24/11/7	2/2	2	1	1	4	2	2	2	1	Y	1	25	Y
PIC16F18156	28K	256	2048	Y/Y	25/Y	3/2	4/2	24/11/7	2/2	2	1	1	4	2	2	2	1	Y	1	25	Y
PIC16F18174	7K	128	512	Y/Y	36/Y	3/2	4/2	35/16/7	2/2	2	1	1	4	2	2	2	1	Y	1	25	Y
PIC16F18175	14K	128	1024	Y/Y	36/Y	3/2	4/2	35/16/7	2/2	2	1	1	4	2	2	2	1	Y	1	25	Y
PIC16F18176	28K	256	2048	Y/Y	36/Y	3/2	4/2	35/16/7	2/2	2	1	1	4	2	2	2	1	Y	1	25	Y

Notes:

1. Total I/O count includes one input-only pin (\overline{MCLR}).
2. Timer0 can be configured as either an 8 or 16-bit timer.

Core Features

- C Compiler Optimized RISC Architecture
- Operating Speed:
 - DC – 32 MHz clock input
 - 125 ns minimum instruction time
- 16-Level Deep Hardware Stack
- Low-Current Power-on Reset (POR)
- Configurable Power-up Timer (PWRT)
- Brown-out Reset (BOR)
- Low-Power Brown-out Reset (LPBOR)
- Windowed Watchdog Timer (WWDT)

Memory

- Up to 28 KB of Program Flash Memory
- Up to 2 KB of Data SRAM Memory
- Up to 256 Bytes of Data EEPROM Memory
- Memory Access Partition (MAP) with Program Flash Memory Partitioned into:
 - Application block

- Boot block
- Storage Area Flash (SAF) block
- Programmable Code Protection and Write Protection
- Device Information Area (DIA) Stores:
 - Temperature Indicator calibration coefficients
 - Fixed Voltage Reference (FVR) measurement data
 - Microchip Unique Identifier (MUI)
- Device Characteristics Information (DCI) Stores:
 - Program/erase row sizes
 - Pin count details
- Direct, Indirect, and Relative Addressing Modes

Operating Characteristics

- Operating Voltage Range:
 - 1.8V to 5.5V
- Temperature Range:
 - Industrial: -40°C to 85°C
 - Extended: -40°C to 125°C

Power-Saving Functionality

- Doze: CPU and Peripherals Running at Different Cycle Rates (typically CPU is lower)
- Idle: CPU Halted While Peripherals Operate
- Sleep:
 - Lowest power consumption
 - Reduce system electrical noise while performing ADC conversions
- Peripheral Module Disable (PMD): Selectively Minimize the Active Power Consumption of Unused Peripherals
- Low-Power Mode Features:
 - Sleep current:
 - < 900 nA typical @ 3V/25°C (WDT enabled)
 - < 600 nA typical @ 3V/25°C (WDT disabled)
 - Operating current:
 - 48 μ A typical @ 32 kHz, 3V/25°C
 - < 1 mA typical @ 4 MHz, 5V/25°C

Digital Peripherals

- Two Capture/Compare/PWM (CCP) Modules:
 - 16-bit resolution for Capture/Compare modes
 - 10-bit resolution for PWM mode
- Up to Four Pulse-Width Modulators (PWM):
 - 16-bit resolution
 - Independent pulse outputs
 - External Reset Signal (ERS) inputs
- Four Configurable Logic Cells (CLC):
 - Integrated combinational and sequential logic

- One Complimentary Waveform Generator (CWG):
 - Rising and falling edge dead-band control
 - Full-bridge, half-bridge, 1-channel drive
 - Multiple signal sources
 - Programmable dead band
 - Fault-shutdown input
- One Configurable 8/16-Bit Timer (TMR0)
- Two 16-Bit Timers (TMR1/3) with Gate Control
- Up to Three 8-Bit Timers (TMR2/4/6) with Hardware Limit Timer (HLT)
- One Numerically Controlled Oscillator (NCO):
 - Generates true linear frequency control and increased frequency resolution
 - Input clock up to 64 MHz
- Programmable CRC with Memory Scan:
 - Reliable data/program memory monitoring for Fail-Safe operation (e.g., Class B)
 - Calculate 32-bit CRC over any portion of Program Flash Memory
- Two Enhanced Universal Synchronous Asynchronous Receiver Transmitters (EUSART):
 - RS-232, RS-485, LIN compatible
 - Auto-wake-up on Start
- Two Host Synchronous Serial Ports (MSSP):
 - Serial Peripheral Interface (SPI) mode
 - Chip Select Synchronization
 - Inter-Integrated Circuit (I²C) mode
 - 7/10-bit Addressing modes
- Peripheral Pin Select (PPS):
 - Enables pin mapping of digital I/O
- Device I/O Port Features:
 - Up to 35 I/O pins
 - One input-only pin
 - Individual I/O direction, open-drain, input threshold, slew rate, and weak pull-up control
 - Interrupt-on-Change (IOC) on up to 25 pins
 - One external interrupt pin

Analog Peripherals

- Differential Analog-to-Digital Converter with Computation (ADCC):
 - 12-bit resolution
 - Up to 35 external positive input channels
 - Up to 17 external negative input channels
 - Seven internal input channels
 - Internal ADC oscillator (ADCRC)
 - Operates in Sleep
 - Selectable Auto-Conversion Trigger (ACT) sources
- Two 8-Bit Digital-to-Analog Converters (DAC):

- Output available on up to two I/O pins
- Internal connections to ADC and Comparators
- Two Comparators (CMP):
 - Up to four external inputs
 - Configurable output polarity
 - External output via Peripheral Pin Select
- Zero-Cross Detect (ZCD):
 - Detect when AC signal on pin crosses ground
- Two Fixed Voltage References (FVR):
 - Selectable 1.024V, 2.048V and 4.096V output levels
 - FVR1 internally connected to ADC
 - FVR2 internally connected to Comparator and DAC

Clocking Structure

- High-Precision Internal Oscillator Block (HFINTOSC):
 - Selectable frequencies up to 32 MHz
 - $\pm 2\%$ at calibration
 - Active Clock Tuning of HFINTOSC for improved accuracy
- Internal 31 kHz Oscillator (LFINTOSC)
- External 32 kHz Secondary Oscillator (SOSC)
- External High-Frequency Clock Input:
 - Three Crystal/Resonator modes
 - Two External Clock (EC) Power modes
 - 4x PLL available for external sources
- Fail-Safe Clock Monitor:
 - Allows for operational recovery if the external clock source stops
- Oscillator Start-up Timer (OST):
 - Ensures the stability of crystal oscillator sources

Programming/Debug Features

- In-Circuit Serial Programming™ (ICSP™) via Two Pins
- In-Circuit Debug (ICD) with Three Breakpoints via Two Pins
- Debug Integrated On-Chip

Block Diagram

Figure 1. PIC16F18126/46 Block Diagram

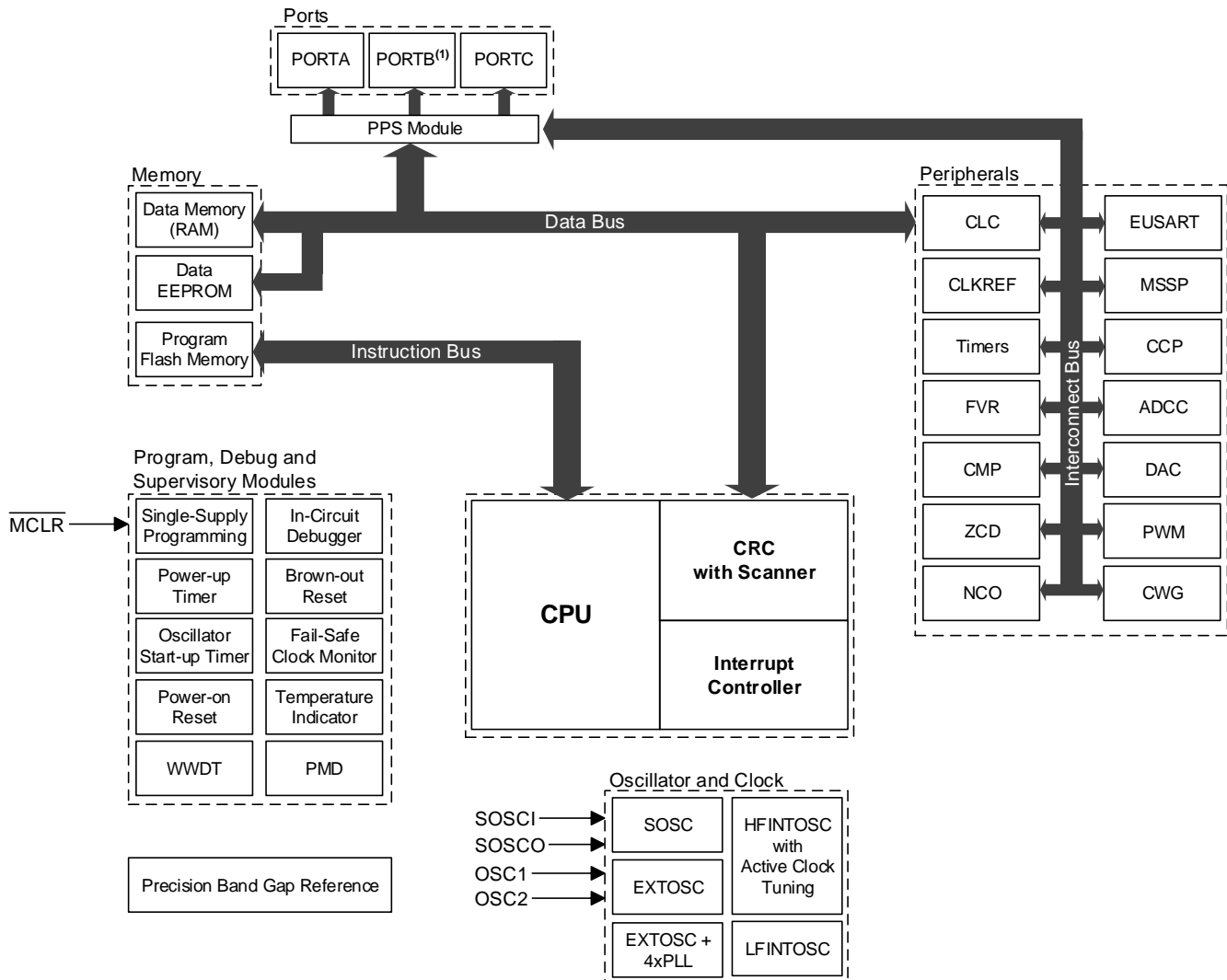

Note:

1. Available on 20-pin devices only.

Table of Contents

Introduction.....	1
PIC16F181 Family Summary.....	1
Core Features.....	2
1. Packages.....	9
2. Pin Diagrams.....	10
3. Pin Allocation Tables.....	12
4. Guidelines for Getting Started with PIC16F181 Microcontrollers.....	16
5. Register and Bit Naming Conventions.....	19
6. Register Legend.....	21
7. Enhanced Mid-Range CPU.....	22
8. Device Configuration.....	24
9. Memory Organization.....	36
10. Resets.....	69
11. OSC - Oscillator Module (With Fail-Safe Clock Monitor).....	81
12. INT - Interrupts	107
13. Power-Saving Modes.....	129
14. WWDT - Windowed Watchdog Timer.....	137
15. NVM - Nonvolatile Memory Control	147
16. I/O Ports.....	172
17. IOC - Interrupt-on-Change.....	187
18. PPS - Peripheral Pin Select Module.....	193
19. CRC - Cyclic Redundancy Check Module with Memory Scanner.....	203
20. PMD - Peripheral Module Disable.....	222
21. CLKREF - Reference Clock Output Module.....	229
22. TMR0 - Timer0 Module.....	234
23. TMR1 - Timer1 Module with Gate Control.....	242
24. TMR2 - Timer2 Module.....	257
25. NCO - Numerically Controlled Oscillator Module.....	278
26. CWG - Complementary Waveform Generator Module.....	287

27. CCP - Capture/Compare/PWM Module.....	315
28. Capture, Compare, and PWM Timers Selection.....	328
29. PWM - Pulse-Width Modulator with Compare.....	331
30. CLC - Configurable Logic Cell.....	358
31. MSSP - Host Synchronous Serial Port Module.....	378
32. EUSART - Enhanced Universal Synchronous Asynchronous Receiver Transmitter.....	442
33. ADC - Analog-to-Digital Converter with Computation Module.....	472
34. DAC - Digital-to-Analog Converter Module.....	523
35. CMP - Comparator Module.....	531
36. FVR - Fixed Voltage Reference.....	542
37. Temperature Indicator Module.....	547
38. ZCD - Zero-Cross Detection Module.....	553
39. Charge Pump.....	561
40. Instruction Set Summary.....	565
41. ICSP™ - In-Circuit Serial Programming™.....	582
42. Register Summary.....	585
43. Electrical Specifications.....	594
44. DC and AC Characteristics Graphs and Tables.....	619
45. Packaging Information.....	620
46. Appendix A: Revision History.....	643
Microchip Information.....	644

1. Packages

Table 1-1. Packages

Device	14-Pin PDIP	14-Pin SOIC	14-Pin TSSOP	16-Pin VQFN 4x4x1	20-Pin PDIP	20-Pin SOIC	20-Pin SSOP	20-Pin VQFN 4x4x1
PIC16F18126	•	•	•	•				
PIC16F18146					•	•	•	•

2. Pin Diagrams

Figure 2-1. 14-Pin PDIP, SOIC, TSSOP

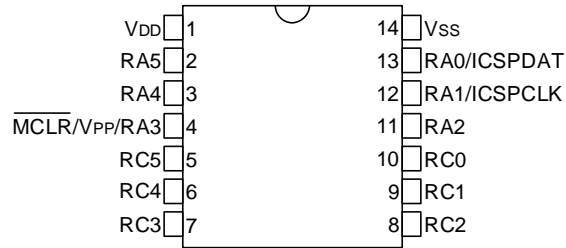
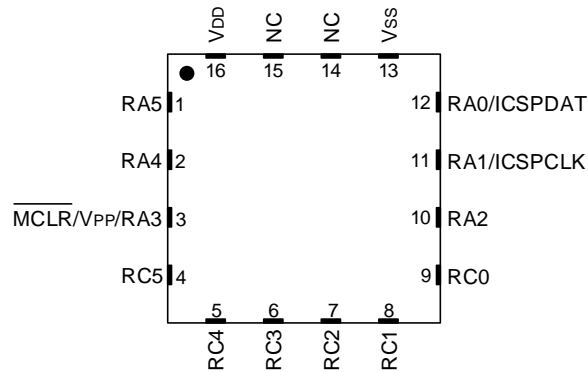

Figure 2-2. 16-Pin VQFN



Note: It is recommended that the exposed bottom pad be connected to V_{SS} , however, it must not be the only V_{SS} connection to the device.

Figure 2-3. 20-Pin PDIP, SOIC, SSOP

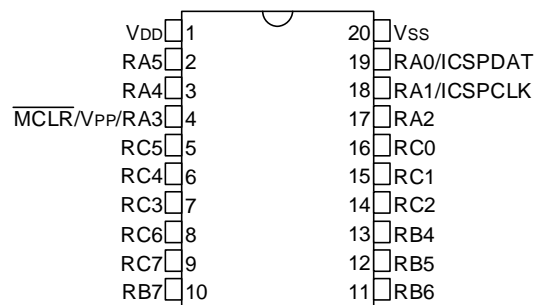
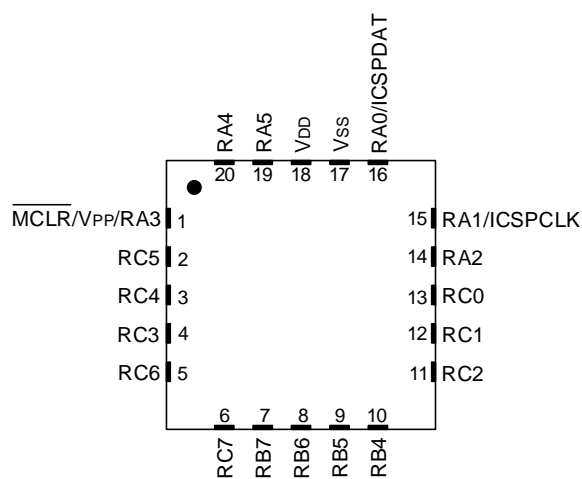

Figure 2-4. 20-Pin VQFN



Note: It is recommended that the exposed bottom pad be connected to V_{SS} , however, it must not be the only V_{SS} connection to the device.

3. Pin Allocation Tables

Table 3-1. 14/16-Pin Allocation Table

I/O	14-Pin PDIP SOIC TSSOP	16-Pin VQFN	ADC	DAC	Comparator	ZCD	Timers	CCP	16-Bit PWM	CWG	CLC	MSSP	EUSART	IOC	Interrupt	Basic
RA0	13	12	ANA0 ⁽⁵⁾	DAC1OUT1	C1IN0+	—	—	—	—	—	—	SS2 ⁽¹⁾	—	IOCA0	—	ICSPDAT ICDDAT
RA1	12	11	ANA1 ⁽⁵⁾ V _{REF+} (ADC)	DAC1REF0+ DAC2REF0+	C1IN0- C2IN0-	—	—	—	—	—	—	—	—	IOCA1	—	ICSPCLK ICDCLK
RA2	11	10	ANA2 ⁽⁵⁾	DAC1REF0- DAC2REF0- DAC1OUT2	—	ZCD1	T0CK1 ⁽¹⁾	—	—	CWG1 ⁽¹⁾	—	—	—	IOCA2	INT ⁽¹⁾	—
RA3	4	3	—	—	—	—	—	—	—	—	—	—	—	IOCA3	—	MCLR V _{PP}
RA4	3	2	ANA4 ⁽⁵⁾	—	—	—	T1G ⁽¹⁾	—	—	—	—	—	—	IOCA4	—	CLKOUT OSC2 SOSCO
RA5	2	1	ANA5 ⁽⁵⁾	—	—	—	T1CK1 ⁽¹⁾ T2IN ⁽¹⁾	—	PWM1ERS ⁽¹⁾	—	CLCIN3 ⁽¹⁾	—	—	IOCA5	—	CLKIN OSC1 SOSCI
RC0	10	9	ANC0 ⁽⁵⁾	—	C2IN0+	—	—	—	—	—	—	SCL1 ^(1,3,4) SCK1 ^(1,3,4)	CK2 ^(1,3)	IOCC0	—	—
RC1	9	8	ANC1 ⁽⁵⁾	—	C1IN1- C2IN1-	—	T4IN ⁽¹⁾	—	PWM2ERS ⁽¹⁾	—	CLCIN2 ⁽¹⁾	SDA1 ^(1,3,4) SDI1 ^(1,3,4)	RX2 ⁽¹⁾ DT2 ^(1,3)	IOCC1	—	—
RC2	8	7	ANC2 ⁽⁵⁾ ADACT ⁽¹⁾	—	C1IN2- C2IN2-	—	—	—	—	—	—	—	—	IOCC2	—	—
RC3	7	6	ANC3 ⁽⁵⁾	—	C1IN3- C2IN3-	—	—	CCP2 ⁽¹⁾	PWMIN1 ⁽¹⁾	—	CLCIN0 ⁽¹⁾	SS1 ⁽¹⁾	—	IOCC3	—	—
RC4	6	5	ANC4 ⁽⁵⁾	—	—	—	T3G ⁽¹⁾	—	—	—	CLCIN1 ⁽¹⁾	SCK2 ^(1,3,4) SCL2 ^(1,3,4)	CK1 ^(1,3)	IOCC4	—	—
RC5	5	4	ANC5 ⁽⁵⁾	—	—	—	T3CK1 ⁽¹⁾	CCP1 ⁽¹⁾	PWMIN0 ⁽¹⁾	—	—	SDA2 ^(1,3,4) SDI2 ^(1,3,4)	RX1 ⁽¹⁾ DT1 ^(1,3)	IOCC5	—	—
V _{DD}	1	16	—	—	—	—	—	—	—	—	—	—	—	—	—	V _{DD}
V _{SS}	14	13	—	—	—	—	—	—	—	—	—	—	—	—	—	V _{SS}

.....continued

I/O	14-Pin PDIP SOIC TSSOP	16-Pin VQFN	ADC	DAC	Comparator	ZCD	Timers	CCP	16-Bit PWM	CWG	CLC	MSSP	EUSART	IOC	Interrupt	Basic
OUT ⁽²⁾	—	—	ADGRDA ADGRDB	—	CMP1 CMP2	—	TMR0	CCP1 CCP2	PWM11 PWM12 PWM21 PWM22	CWG1A CWG1B CWG1C CWG1D	CLC1OUT CLC2OUT CLC3OUT CLC4OUT	SCL1 SCK1 SDA1 SDO1 SCL2 SCK2 SDA2 SDO2	TX1 DT1 CK1 TX2 DT2 CK2	—	—	—

Notes:

1. This is a PPS remappable input signal. The input function may be moved from the default location shown to any PORTx pin.
2. All output signals shown in this row are PPS remappable.
3. This is a bidirectional signal. For normal operation, user software must map this signal to the same pin via the PPS input and PPS output registers.
4. These pins can be configured for I²C or SMBus logic levels via the RxyI2C registers. The SCL1/SDA1 signals may be assigned to these pins for expected operation. PPS assignments of these signals to other pins will operate; however, the logic levels will be standard TTL/ST as selected by the INLVL register.
5. This pin can be used as either a positive or negative analog input channel to the ADC.

Table 3-2. 20-Pin Allocation Table

I/O	20-Pin PDIP SOIC SSOP	20-Pin VQFN	ADC	DAC	Comparator	ZCD	Timers	CCP	16-Bit PWM	CWG	CLC	MSSP	EUSART	IOC	Interrupt	Basic
RA0	19	16	ANA0 ⁽⁵⁾	DAC1OUT1	C1IN0+	—	—	—	—	—	—	—	—	IOCA0	—	ICSPDAT ICDDAT
RA1	18	15	ANA1 ⁽⁵⁾ V _{REF+} (ADC)	DAC1REF0+ DAC2REF0+	C1IN0- C2IN0-	—	—	—	—	—	—	SS2 ⁽¹⁾	—	IOCA1	—	ICSPCLK ICDCLK
RA2	17	14	ANA2 ⁽⁵⁾	DAC1REF0- DAC2REF0- DAC1OUT2	—	ZCD1	T0CKI ⁽¹⁾	—	—	CWG1 ⁽¹⁾	CLCIN0 ⁽¹⁾	—	—	IOCA2	INT ⁽¹⁾	—
RA3	4	1	—	—	—	—	—	—	—	—	—	—	—	IOCA3	—	MCLR V _{PP}
RA4	3	20	ANA4 ⁽⁵⁾	—	—	—	T1G ⁽¹⁾	—	—	—	—	—	—	IOCA4	—	CLKOUT OSC2 SOSCO
RA5	2	19	ANA5 ⁽⁵⁾	—	—	—	T1CKI ⁽¹⁾ T2IN ⁽¹⁾	—	PWM1ERS ⁽¹⁾	—	—	—	—	IOCA5	—	CLKIN OSC1 SOSCI
RB4	13	10	ANB4 ⁽⁵⁾	—	—	—	—	—	—	—	CLCIN2 ⁽¹⁾	SDA1 ^(1,3,4) SDI1 ^(1,3,4)	—	IOCB4	—	—
RB5	12	9	ANB5 ⁽⁵⁾	—	—	—	—	—	—	—	CLCIN3 ⁽¹⁾	SDA2 ^(1,3,4) SDI2 ^(1,3,4)	RX1 ⁽¹⁾ DT1 ^(1,3)	IOCB5	—	—
RB6	11	8	ANB6 ⁽⁵⁾	—	—	—	—	—	—	—	—	SCL1 ^(1,3,4) SCK1 ^(1,3,4)	—	IOCB6	—	—
RB7	10	7	ANB7 ⁽⁵⁾	—	—	—	—	—	—	—	—	SCL2 ^(1,3,4) SCK2 ^(1,3,4)	CK1 ^(1,3)	IOCB7	—	—
RC0	16	13	ANC0 ⁽⁵⁾	—	C2IN0+	—	—	—	—	—	—	—	CK2 ^(1,3)	IOCC0	—	—
RC1	15	12	ANC1 ⁽⁵⁾	—	C1IN1- C2IN1-	—	T4IN ⁽¹⁾	—	PWM2ERS ⁽¹⁾	—	—	—	RX2 ⁽¹⁾ DT2 ^(1,3)	IOCC1	—	—
RC2	14	11	ANC2 ⁽⁵⁾ ADACT ⁽¹⁾	—	C1IN2- C2IN2-	—	—	—	—	—	—	—	—	IOCC2	—	—
RC3	7	4	ANC3 ⁽⁵⁾	—	C1IN3- C2IN3-	—	—	CCP2 ⁽¹⁾	PWMIN1 ⁽¹⁾	—	CLCIN1 ⁽¹⁾	—	—	IOCC3	—	—
RC4	6	3	ANC4 ⁽⁵⁾	—	—	—	T3G ⁽¹⁾	—	—	—	—	—	—	IOCC4	—	—
RC5	5	2	ANC5 ⁽⁵⁾	—	—	—	T3CKI ⁽¹⁾	CCP1 ⁽¹⁾	PWMIN0 ⁽¹⁾	—	—	—	—	IOCC5	—	—
RC6	8	5	ANC6 ⁽⁵⁾	—	—	—	—	—	—	—	—	SS1 ⁽¹⁾	—	IOCC6	—	—
RC7	9	6	ANC7 ⁽⁵⁾	—	—	—	—	—	—	—	—	—	—	IOCC7	—	—
V _{DD}	1	18	—	—	—	—	—	—	—	—	—	—	—	—	—	V _{DD}
V _{SS}	20	17	—	—	—	—	—	—	—	—	—	—	—	—	—	V _{SS}

.....continued

I/O	20-Pin PDIP SOIC SSOP	20-Pin VQFN	ADC	DAC	Comparator	ZCD	Timers	CCP	16-Bit PWM	CWG	CLC	MSSP	EUSART	IOC	Interrupt	Basic
OUT ⁽²⁾	—	—	ADGRDA ADGRDB	—	CMP1 CMP2	—	TMR0	CCP1 CCP2	PWM11 PWM12 PWM21 PWM22	CWG1A CWG1B CWG1C CWG1D	CLC1OUT CLC2OUT CLC3OUT CLC4OUT	SCL1 SCK1 SDA1 SDO1 SCL2 SCK2 SDA2 SDO2	TX1 DT1 CK1 TX2 DT2 CK2	—	—	—

Notes:

1. This is a PPS remappable input signal. The input function may be moved from the default location shown to any PORTx pin.
2. All output signals shown in this row are PPS remappable.
3. This is a bidirectional signal. For normal operation, user software must map this signal to the same pin via the PPS input and PPS output registers.
4. These pins can be configured for I²C or SMBus logic levels via the RxyI2C registers. The SCL1/SDA1 signals may be assigned to these pins for expected operation. PPS assignments of these signals to other pins will operate; however, the logic levels will be standard TTL/ST as selected by the INLVL register.
5. This pin can be used as either a positive or negative analog input channel to the ADC.

4. Guidelines for Getting Started with PIC16F181 Microcontrollers

4.1 Basic Connection Requirements

Getting started with the PIC16F181 family of 8-bit microcontrollers requires attention to a minimal set of device pin connections before proceeding with development.

The following pins must always be connected:

- All V_{DD} and V_{SS} pins (see [Power Supply Pins](#))
- \overline{MCLR} pin (see [Master Clear \(MCLR\) Pin](#))

These pins must also be connected if they are being used in the end application:

- PGC/PGD pins used for In-Circuit Serial Programming™ (ICSP™) and debugging purposes (see [In-Circuit Serial Programming \(ICSP\) Pins](#))
- CLKIN pin when an external clock source is used.

Additionally, the following may be required:

- V_{REF+}/V_{REF-} pins are used when external voltage reference for analog modules is implemented

The minimum recommended connections are shown in the figure below.

Figure 4-1. Minimum Recommended Connections

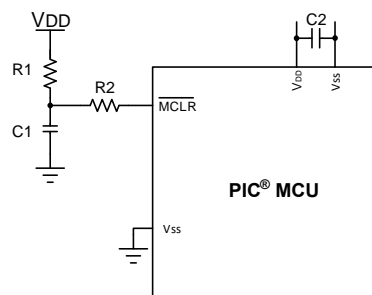

Key (all values are recommendations):

- C1: 10 nF, 16V ceramic
- C2: 0.1 μ F, 16V ceramic
- R1: 10 k Ω
- R2: 100 Ω to 470 Ω

4.2 Power Supply Pins

4.2.1 Decoupling Capacitors

The use of decoupling capacitors on every pair of power supply pins (V_{DD} and V_{SS}) is required.

Consider the following criteria when using decoupling capacitors:

- Value and type of capacitor: A 0.1 μ F (100 nF), 10-25V capacitor is recommended. The capacitor may be a low-ESR device, with a resonance frequency in the range of 200 MHz and higher. Ceramic capacitors are recommended.
- Placement on the printed circuit board: The decoupling capacitors may be placed as close to the pins as possible. It is recommended to place the capacitors on the same side of the board as the device. If space is constricted, the capacitor can be placed on another layer on the PCB using a

via; however, ensure that the trace length from the pin to the capacitor is no greater than 0.25 inch (6 mm).

- Handling high-frequency noise: If the board is experiencing high-frequency noise (upward of tens of MHz), add a second ceramic type capacitor in parallel to the above described decoupling capacitor. The value of the second capacitor can be in the range of 0.01 μF to 0.001 μF . Place this second capacitor next to each primary decoupling capacitor. In high-speed circuit designs, consider implementing a decade pair of capacitances as close to the power and ground pins as possible (e.g., 0.1 μF in parallel with 0.001 μF).
- Maximizing performance: On the board layout from the power supply circuit, run the power and return traces to the decoupling capacitors first and then to the device pins. This ensures that the decoupling capacitors are first in the power chain. Equally important is to keep the trace length between the capacitor and the power pins to a minimum, thereby reducing PCB trace inductance.

4.2.2 Tank Capacitors

With on boards with power traces running longer than six inches in length, it is suggested to use a tank capacitor for integrated circuits, including microcontrollers, to supply a local power source. The value of the tank capacitor may be determined based on the trace resistance that connects the power supply source to the device and the maximum current drawn by the device in the application. In other words, select the tank capacitor that meets the acceptable voltage sag at the device. Typical values range from 4.7 μF to 47 μF .

4.3 Master Clear ($\overline{\text{MCLR}}$) Pin

The $\overline{\text{MCLR}}$ pin provides two specific device functions: Device Reset and device programming and debugging. If programming and debugging are not required in the end application, a direct connection to V_{DD} may be all that is required. The addition of other components, to help increase the application's resistance to spurious Resets from voltage sags, may be beneficial. A typical configuration is shown in Figure 4-1. Other circuit designs may be implemented, depending on the application's requirements.

During programming and debugging, the resistance and capacitance that can be added to the pin must be considered. Device programmers and debuggers drive the $\overline{\text{MCLR}}$ pin. Consequently, specific voltage levels (V_{IH} and V_{IL}) and fast signal transitions must not be adversely affected. Therefore, specific values of R1 and C1 will need to be adjusted based on the application and PCB requirements. For example, it is recommended that the capacitor, C1, be isolated from the $\overline{\text{MCLR}}$ pin during programming and debugging operations by using a jumper (Figure 4-2). The jumper is replaced for normal run-time operations.

Any components associated with the $\overline{\text{MCLR}}$ pin may be placed within 0.25 inch (6 mm) of the pin.

Figure 4-2. Example of $\overline{\text{MCLR}}$ Pin Connections

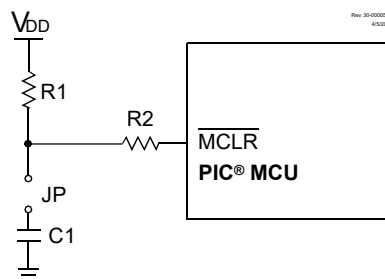

Notes:

1. $R1 \leq 10 \text{ k}\Omega$ is recommended. A suggested starting value is $10 \text{ k}\Omega$. Ensure that the $\overline{\text{MCLR}}$ pin V_{IH} and V_{IL} specifications are met.
2. $R2 \leq 470\Omega$ will limit any current flowing into $\overline{\text{MCLR}}$ from the extended capacitor, C1, in the event of $\overline{\text{MCLR}}$ pin breakdown, due to Electrostatic Discharge (ESD) or Electrical Overstress (EOS). Ensure that the $\overline{\text{MCLR}}$ pin V_{IH} and V_{IL} specifications are met.

4.4 In-Circuit Serial Programming™ (ICSP™) Pins

The ICSPCLK and ICSPDAT pins are used for ICSP and debugging purposes. It is recommended to keep the trace length between the ICSP connector and the ICSP pins on the device as short as possible. If the ICSP connector is expected to experience an ESD event, a series resistor is recommended, with the value in the range of a few tens of ohms, not to exceed 100Ω .

Pull-up resistors, series diodes and capacitors on the ICSPCLK and ICSPDAT pins are not recommended as they can interfere with the programmer/debugger communications to the device. If such discrete components are an application requirement, they may be removed from the circuit during programming and debugging. Alternatively, refer to the AC/DC characteristics and timing requirements information in the respective device Flash programming specification for information on capacitive loading limits and pin input voltage high (V_{IH}) and input low (V_{IL}) requirements.

For device emulation, ensure that the Communication Channel Select (i.e., ICSPCLK/ICSPDAT pins), programmed into the device, matches the physical connections for the ICSP to the Microchip debugger/emulator tool.

4.5 Unused I/Os

Unused I/O pins may be configured as outputs and driven to a Logic Low state. Alternatively, connect a $1 \text{ k}\Omega$ to $10 \text{ k}\Omega$ resistor to V_{SS} on unused pins to drive the output to Logic Low.

5. Register and Bit Naming Conventions

5.1 Register Names

When there are multiple instances of the same peripheral in a device, the Peripheral Control registers will be depicted as the concatenation of a peripheral identifier, peripheral instance, and control identifier. The Control registers section will show just one instance of all the register names with an 'x' in the place of the peripheral instance number. This naming convention may also be applied to peripherals when there is only one instance of that peripheral in the device to maintain compatibility with other devices in the family that contain more than one.

5.2 Bit Names

There are two variants for bit names:

- Short name: Bit function abbreviation
- Long name: Peripheral abbreviation + short name

5.2.1 Short Bit Names

Short bit names are an abbreviation for the bit function. For example, some peripherals are enabled with the EN bit. The bit names shown in the registers are the short name variant.

Short bit names are useful when accessing bits in C programs. The general format for accessing bits by the short name is `RegisterNamebits.ShortName`. For example, the enable bit, ON, in the ADCON0 register can be set in C programs with the instruction `ADCON0bits.ON = 1`.

Short names are not useful in assembly programs because the same name may be used by different peripherals in different bit positions. When it occurs, during the include file generation, the short bit name instances are appended with an underscore plus the name of the register where the bit resides, to avoid naming contentions.

5.2.2 Long Bit Names

Long bit names are constructed by adding a peripheral abbreviation prefix to the short name. The prefix is unique to the peripheral, thereby making every long bit name unique. The long bit name for the ADC enable bit is the ADC prefix, AD, appended with the enable bit short name, ON, resulting in the unique bit name ADON.

Long bit names are useful in both C and assembly programs. For example, in C the ADCON0 enable bit can be set with the `ADON = 1` instruction. In assembly, this bit can be set with the `BSF ADCON0, ADON` instruction.

5.2.3 Bit Fields

Bit fields are two or more adjacent bits in the same register. Bit fields adhere only to the short bit naming convention. For example, the three Least Significant bits of the ADCON2 register contain the ADC Operating Mode Selection bit. The short name for this field is MD and the long name is ADMD. Bit field access is only possible in C programs. The following example demonstrates a C program instruction for setting the ADC to operate in Accumulate mode:

```
ADCON2bits.MD = 0b001;
```

Individual bits in a bit field can also be accessed with long and short bit names. Each bit is the field name appended with the number of the bit position within the field. For example, the Most Significant MODE bit has the short bit name MD2 and the long bit name is ADMD2. The following two examples demonstrate assembly program sequences for setting the ADC to operate in Accumulate mode:

```
MOVLW  ~(1<<MD2 | 1<<MD1)
ANDWF  ADCON2, F
```

```
MOVLW 1<<MD0  
IORWF ADCON2, F
```

```
BCF ADCON2, ADMD2  
BCF ADCON2, ADMD1  
BSF ADCON2, ADMD0
```

5.3 Register and Bit Naming Exceptions

5.3.1 Status, Interrupt and Mirror Bits

Status, Interrupt enables, Interrupt flags and Mirror bits are contained in registers that span more than one peripheral. In these cases, the bit name shown is unique so there is no prefix or short name variant.

6. Register Legend

Table 6-1. Register Legend

Symbol	Definition
R	Readable bit
W	Writable bit
HS	Hardware settable bit
HC	Hardware clearable bit
S	Set only bit
C	Clear only bit
U	Unimplemented bit, read as '0'
'1'	Bit value is set
'0'	Bit value is cleared
x	Bit value is unknown
u	Bit value is unchanged
q	Bit value depends on condition
m	Bit value is predefined

7. Enhanced Mid-Range CPU

This family of devices contains an enhanced mid-range 8-bit CPU core. The CPU has 50 instructions. Interrupt capability includes automatic context saving. The hardware stack is 16-level deep and has overflow and underflow Reset capability. Direct, Indirect, and Relative Addressing modes are available. Two File Select Registers (FSR) provide the ability to read program and data memory.

Figure 7-1. Core Data Path Diagram

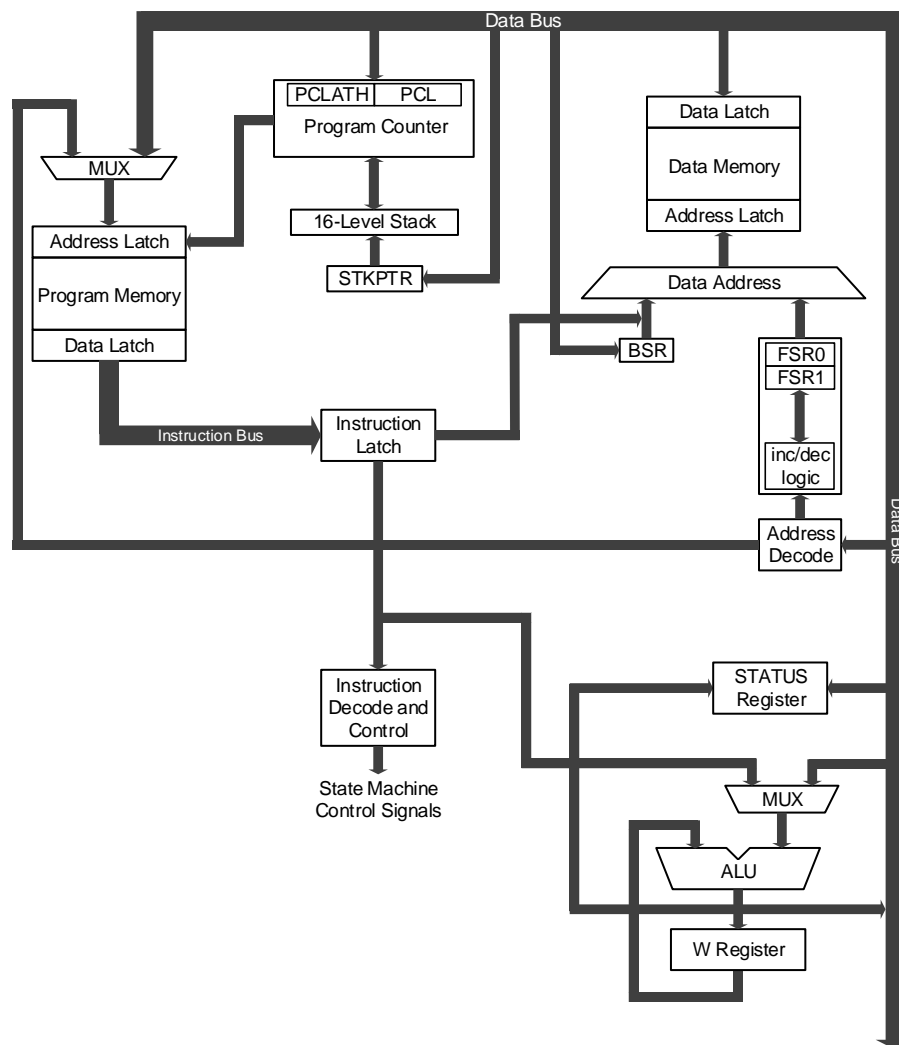

7.1 Automatic Interrupt Context Saving

During interrupts, certain registers are automatically saved in shadow registers and restored when returning from the interrupt. This saves stack space and user code.

7.2 16-Level Stack with Overflow and Underflow

These devices have a hardware stack memory 15 bits wide and 16 words deep. A Stack Overflow or Underflow will set the appropriate bit (**STKOVF** or **STKUNF**) and, if enabled, will cause a software Reset.

7.3 File Select Registers

There are two 16-bit File Select Registers (FSR). FSRs can access all file registers and program memory, which allows one Data Pointer for all memory. When an FSR points to program memory, there is one additional instruction cycle in instructions using INDF to allow the data to be fetched. General purpose memory can also be addressed linearly, providing the ability to access contiguous data larger than 80 bytes.

7.4 Instruction Set

There are 50 instructions for the enhanced mid-range CPU to support the features of the CPU. See the **“Instruction Set Summary”** chapter for more details.

8. Device Configuration

Device configuration consists of the Configuration Words, User ID, Device ID, Device Information Area (DIA) and the Device Configuration Information (DCI) regions.

8.1 Configuration Words

There are five Configuration Words that allow the user to select the device oscillator, Reset and memory protection options. These are implemented at addresses 0x8007 - 0x800B.

Note: The DEBUG bit in the Configuration Words is managed automatically by device development tools, including debuggers and programmers. For normal device operation, this bit needs to be maintained as a '1'.

8.2 Code Protection

Program memory code protection is controlled using the \overline{CP} bit, while data EEPROM memory code protection is controlled using the \overline{CPD} bit. When code protection is enabled, all program memory and Data EEPROM locations read as '0'. Further programming is disabled for the program memory and Data EEPROM, until a Bulk Erase operation is performed on the configuration memory region. Program memory and Data EEPROM can still be programmed and read during program execution.

The User ID locations and Configuration Bytes can be programmed and read out regardless of the code protection settings.

The only way to disable code protection is to use the Bulk Erase Program Memory command with bit 4 of the payload set to '1'. This will disable code protection and erase all memory locations.

8.3 Write Protection

Write protection allows the device to be protected from unintended self-writes. Applications, such as bootloader software, can be protected while allowing other regions of the program memory to be modified.

The \overline{WRTn} Configuration bits determine which of the program memory blocks are protected.

8.4 User ID

Four words in the memory space (8000h-8003h) are designated as ID locations where the user can store checksum or other code identification numbers. These locations are readable and writable during normal execution. See the **"NVMREG Access to DIA, DCI, User ID, DEV/REV ID, and Configuration Words"** section in the **"NVM - Nonvolatile Memory Control"** chapter for more information on accessing these memory locations. For more information on checksum calculation, see the **"Memory Programming Specifications"** section in the **"Electrical Specifications"** chapter for more information on accessing these memory locations. For more information on checksum calculation, see the **"Family Programming Specification"**.

8.5 Device ID and Revision ID

The 14-bit Device ID word is located at address 8006h and the 14-bit Revision ID is located at 8005h. These locations are read-only and cannot be erased or modified.

Development tools, such as device programmers and debuggers, may be used to read the Device ID, Revision ID and Configuration Words. Refer to the **"NVM - Nonvolatile Memory Control"** chapter for more information on accessing these locations.

8.6 Register Definitions: Configuration Settings

8.6.1 CONFIG1

Name: CONFIG1
Offset: 0x8007

Configuration Word 1

Bit	15	14	13	12	11	10	9	8
			FCMEN	VDDAR	CSWEN			CLKOUTEN
Access			R/W	R/W	R/W			R/W
Reset			1	1	1			1
Bit	7	6	5	4	3	2	1	0
		RSTOSC[2:0]				FEXTOSC[2:0]		
Access		R/W	R/W	R/W		R/W	R/W	R/W
Reset		1	1	1		1	1	1

Bit 13 – FCMEN Fail-Safe Clock Monitor Enable

Value	Description
1	Fail-Safe Clock Monitor is enabled
0	Fail-Safe Clock Monitor is disabled

Bit 12 – VDDAR V_{DD} Analog Range Calibration Selection

Value	Description
1	Internal analog systems are calibrated for operation between V _{DD} = 2.3V - 5.5V
0	Internal analog systems are calibrated for operation between V _{DD} = 1.8V - 3.6V

Bit 11 – CSWEN Clock Switch Enable

Value	Description
1	Writing to NOSC and NDIV is allowed
0	The NOSC and NDIV bit fields cannot be changed by user software

Bit 8 – CLKOUTEN Clock Out Enable

Value	Description
1	CLKOUT function is disabled; I/O function on CLKOUT pin
0	CLKOUT function is enabled; F _{OSC} /4 clock appears on CLKOUT pin

Bits 6:4 – RSTOSC[2:0] Power-up Default Value for the NOSC/COSC bits Selects the oscillator source used by user software.

Value	Description
111	EXTOSC operating per the FEXTOSC bits
110	HFINTOSC = 1 MHz (FRQ = 4 MHz, CDIV = 4:1)
101	LFINTOSC
100	SOSC
011	Reserved
010	EXTOSC with 4x PLL, EXTOSC operating per FEXTOSC bits
001	HFINTOSC = 16 MHz (FRQ = 16 MHz, CDIV = 1:1)
000	HFINTOSC = 32 MHz (FRQ = 32 MHz, CDIV = 1:1)

Bits 2:0 – FEXTOSC[2:0] External Oscillator Mode Selection

Value	Description
111	ECH (16 MHz and higher)
110	Reserved
101	ECL (below 16 MHz)
100	Oscillator not enabled
011	Reserved

Value	Description
010	HS (crystal oscillator) above 4 MHz
001	XT (crystal oscillator) between 100 kHz and 4 MHz
000	LP (crystal oscillator) 32 kHz

8.6.2 CONFIG2

Name: CONFIG2
Offset: 0x8008

Configuration Word 2

Bit	15	14	13	12	11	10	9	8
			DEBUG	STVREN	PPS1WAY	ZCD	BORV	DACAUTOEN
Access			R/W	R/W	R/W	R/W	R/W	R/W
Reset			1	1	1	1	1	1
Bit	7	6	5	4	3	2	1	0
	BOREN[1:0]		LPBOREN			PWRTS[1:0]		MCLRE
Access	R/W	R/W	R/W			R/W	R/W	R/W
Reset	1	1	1			1	1	1

Bit 13 – **DEBUG** Debugger Enable⁽¹⁾

Value	Description
1	Background debugger disabled
0	Background debugger enabled

Bit 12 – **STVREN** Stack Overflow/Underflow Reset Enable

Value	Description
1	Stack Overflow or Underflow will cause a Reset
0	Stack Overflow or Underflow will not cause a Reset

Bit 11 – **PPS1WAY** PPSLOCKED One-Way Set Enable

Value	Description
1	The PPSLOCKED bit can only be set once after an unlocking sequence is executed; once PPSLOCKED is set, all future changes to PPS registers are prevented
0	The PPSLOCKED bit can be set and cleared as needed (unlocking sequence is required)

Bit 10 – **ZCD** Zero-Cross Detect Disable

Value	Description
1	ZCD disabled, ZCD can be enabled by setting the ZCDSEN bit of ZCDCON
0	ZCD always enabled, the PMDx [ZCDMD] bit is ignored

Bit 9 – **BORV** Brown-out Reset (BOR) Voltage Selection⁽²⁾

Value	Description
1	Brown-out Reset voltage (V_{BOR}) set to 1.9V
0	Brown-out Reset voltage (V_{BOR}) set to 2.65V

Bit 8 – **DACAUTOEN** DAC Buffer Automatic Range Select Enable⁽³⁾

Value	Description
1	DAC Buffer reference range is determined by the REFRNG bit of DACxCON
0	DAC Buffer reference range is automatically determined by module hardware

Bits 7:6 – **BOREN[1:0]** Brown-out Reset (BOR) Enable⁽⁴⁾

Value	Description
11	Brown-out Reset enabled, the SBOREN bit is ignored
10	Brown-out Reset enabled while running, disabled in Sleep; the SBOREN bit is ignored
01	Brown-out Reset enabled according to SBOREN
00	Brown-out Reset disabled

Bit 5 – **LPBOREN** Low-Power BOR Enable

Value	Description
1	Low-Power BOR disabled
0	Low-Power BOR enabled

Bits 2:1 – PWRTS[1:0] Power-Up Timer (PWRT) Selection

Value	Description
11	PWRT disabled
10	PWRT is set at 64 ms
01	PWRT is set at 16 ms
00	PWRT is set at 1 ms

Bit 0 – MCLRE Master Clear ($\overline{\text{MCLR}}$) Enable

Value	Condition	Description
x	If LVP = 1	$\overline{\text{MCLR}}$ pin is $\overline{\text{MCLR}}$
1	If LVP = 0	$\overline{\text{MCLR}}$ pin is $\overline{\text{MCLR}}$
0	If LVP = 0	$\overline{\text{MCLR}}$ pin function is port-defined function

Notes:

1. The $\overline{\text{DEBUG}}$ bit is managed automatically by device development tools including debuggers and programmers. For normal device operation, this bit needs to be maintained as a '1'.
2. The higher voltage selection is recommended for operation at or above 16 MHz.
3. The REFRNG bit is not available on the internal-only DAC (DAC2).
4. When enabled, Brown-out Reset voltage (V_{BOR}) is set by the BORV bit.

8.6.3 CONFIG3

Name: CONFIG3

Offset: 0x8009

Configuration Word 3

Note: This register is reserved.

Bit	15	14	13	12	11	10	9	8
			WDTCSS[2:0]			WDTCS[2:0]		
Access			R/W	R/W	R/W	R/W	R/W	R/W
Reset			1	1	1	1	1	1
Bit	7	6	5	4	3	2	1	0
			WDTE[1:0]		WDTCP[4:0]			
Access		R/W	R/W	R/W	R/W	R/W	R/W	R/W
Reset		1	1	1	1	1	1	1

Bits 13:11 – WDTCSS[2:0] WDT Input Clock Selector

Value	Condition	Description
x	WDTE = 00	These bits have no effect
111	WDTE ≠ 00	Software control
110 to 011	WDTE ≠ 00	Reserved
010	WDTE ≠ 00	WDT reference clock is the SOSC
001	WDTE ≠ 00	WDT reference clock is the 31.25 kHz MFINTOSC
000	WDTE ≠ 00	WDT reference clock is the 31.0 kHz LFINTOSC

Bits 10:8 – WDTCS[2:0] WDT Window Select

WDTCS	WDTCON1[WINDOW] at POR			Software Control of WINDOW	Keyed Access Required?
	Value	Window Delay Percent of Time	Window Opening Percent of Time		
111	111	n/a	100	Yes	No
110	110	n/a	100		
101	101	25	75		
100	100	37.5	62.5		
011	011	50	50	No	Yes
010	010	62.5	37.5		
001	001	75	25		
000	000	87.5	12.5		

Bits 6:5 – WDTE[1:0] WDT Operating Mode

Value	Description
11	WDT enabled regardless of Sleep; the SEN bit in WDTCON0 is ignored
10	WDT enabled while Sleep = 0, suspended when Sleep = 1; the SEN bit in WDTCON0 is ignored
01	WDT enabled/disabled by the SEN bit in WDTCON0
00	WDT disabled, the SEN bit in WDTCON0 is ignored

Bits 4:0 – WDTCP[4:0] WDT Period Select

WDTCP	WDTCON0[WDTPS] at POR			Software Control of WDTPS?
	Value	Divider Ratio	Typical Time-Out (F _{IN} = 31 kHz)	
11111	01011	1:65536 2 ¹⁶	2s	Yes

.....continued

WDTCP5	WDTCON0[WDTPS] at POR			Typical Time-Out (F _{IN} = 31 kHz)	Software Control of WDTPS?
	Value	Divider Ratio			
11110 to 10011	11110 to 10011	1:32	2 ⁵	1 ms	No
10010	10010	1:8388608	2 ²³	256s	No
10001	10001	1:4194304	2 ²²	128s	No
10000	10000	1:2097152	2 ²¹	64s	No
01111	01111	1:1048576	2 ²⁰	32s	No
01110	01110	1:524288	2 ¹⁹	16s	No
01101	01101	1:262144	2 ¹⁸	8s	No
01100	01100	1:131072	2 ¹⁷	4s	No
01011	01011	1:65536	2 ¹⁶	2s	No
01010	01010	1:32768	2 ¹⁵	1s	No
01001	01001	1:16384	2 ¹⁴	512 ms	No
01000	01000	1:8192	2 ¹³	256 ms	No
00111	00111	1:4096	2 ¹²	128 ms	No
00110	00110	1:2048	2 ¹¹	64 ms	No
00101	00101	1:1024	2 ¹⁰	32 ms	No
00100	00100	1:512	2 ⁹	16 ms	No
00011	00011	1:256	2 ⁸	8 ms	No
00010	00010	1:128	2 ⁷	4 ms	No
00001	00001	1:64	2 ⁶	2 ms	No
00000	00000	1:32	2 ⁵	1 ms	No

8.6.4 CONFIG4

Name: CONFIG4
Offset: 0x800A

Configuration Word 4

Bit	15	14	13	12	11	10	9	8
			LVP		WRTSAF	WRTD	WRTC	WRTB
Access			R/W		R/W	R/W	R/W	R/W
Reset			1		1	1	1	1
Bit	7	6	5	4	3	2	1	0
	WRTAPP			SAFEN	BBEN	BBSIZE[2:0]		
Access	R/W			R/W	R/W	R/W	R/W	R/W
Reset	1			1	1	1	1	1

Bit 13 - LVP Low-Voltage Programming Enable⁽¹⁾

Value	Description
1	Low-Voltage Programming is enabled. MCLR/V _{PP} pin function is MCLR. The MCLRE bit is ignored.
0	High voltage (HV) on MCLR/V _{PP} must be used for programming

Bit 11 - WRTSAF Storage Area Flash (SAF) Write Protection^(2,3)

Value	Description
1	SAF is not write-protected
0	SAF is write-protected

Bit 10 - WRTD Data EEPROM Write Protection

Value	Description
1	Data EEPROM is not write-protected
0	Data EEPROM is write-protected

Bit 9 - WRTC Configuration Registers Write Protection⁽²⁾

Value	Description
1	Configuration registers are not write-protected
0	Configuration registers are write-protected

Bit 8 - WRTB Boot Block Write Protection^(2,4)

Value	Description
1	Boot Block is not write-protected
0	Boot Block is write-protected

Bit 7 - WRTAPP Application Block Write Protection⁽²⁾

Value	Description
1	Application Block is not write-protected
0	Application Block is write-protected

Bit 4 - SAFEN Storage Area Flash (SAF) Enable⁽²⁾

Value	Description
1	SAF is disabled
0	SAF is enabled

Bit 3 - BBEN Boot Block Enable⁽²⁾

Value	Description
1	Boot Block is disabled
0	Boot Block is enabled

Bits 2:0 – BBSIZE[2:0] Boot Block Size Selection^(5,6)

Table 8-1. Boot Block Size

$\overline{\text{BBEN}}$	BBSIZE	End Address of Boot Block	Boot Block Size (words)	
			PIC16F18126	PIC16F18146
1	xxx	-	-	-
0	111	01FFh	512	
0	110	03FFh	1024	
0	101	07FFh	2048	
0	100	0FFFh	4096	
0	011	1FFFh	8192	
0	010	3FFFh	.. ⁽⁶⁾	
0	001	3FFFh	.. ⁽⁶⁾	
0	000	3FFFh	.. ⁽⁶⁾	

Notes:

1. The LVP bit cannot be written (to zero) while operating from the LVP programming interface. The purpose of this rule is to prevent the user from dropping out of LVP mode while programming from LVP mode or accidentally eliminating LVP mode from the Configuration state.
2. Once protection is enabled through ICSP or a self-write, it can only be reset through a Bulk Erase.
3. Applicable only if $\overline{\text{SAFEN}} = 0$.
4. Applicable only if $\overline{\text{BBEN}} = 0$.
5. BBSIZE[2:0] bits can only be changed when $\overline{\text{BBEN}} = 1$. Once $\overline{\text{BBEN}} = 0$, BBSIZE[2:0] can only be changed through a Bulk Erase.
6. The maximum Boot Block size is half of the user program memory size. Any selection that will exceed the half of a device's program memory will default to a maximum Boot Block size of half PFM.

8.6.5 CONFIG5

Name: CONFIG5
Offset: 0x800B

Configuration Word 5⁽¹⁾

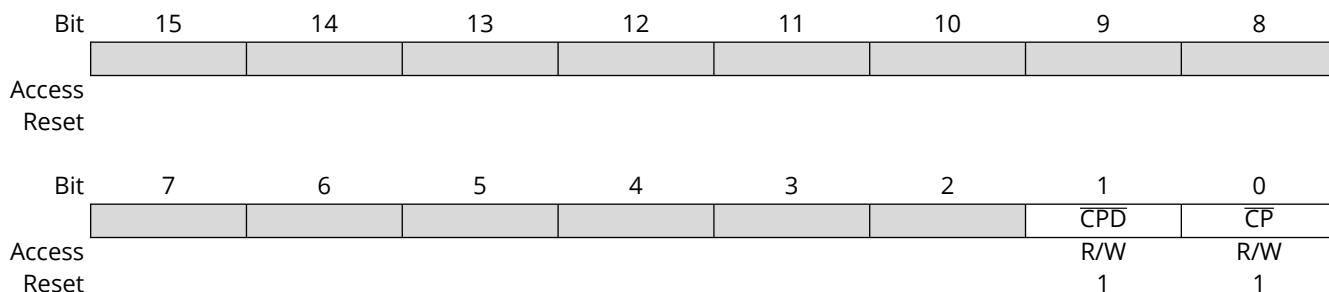

Bit 1 - $\overline{\text{CPD}}$ Data EEPROM Code Protection⁽²⁾

Value	Description
1	Data EEPROM code protection is disabled
0	Data EEPROM code protection is enabled

Bit 0 - $\overline{\text{CP}}$ User Program Flash Memory (PFM) Code Protection⁽²⁾

Value	Description
1	User PFM code protection is disabled
0	User PFM code protection is enabled

Notes:

1. Since device code protection takes effect immediately, this Configuration Word may be written last.
2. Once code protection is enabled, it can only be removed through a Bulk Erase.

8.7 Register Definitions: Device ID and Revision ID

8.7.1 Device ID

Name: DEVICEID
Offset: 0x8006

Device ID Register

Bit	15	14	13	12	11	10	9	8
			Reserved	Reserved	DEV[11:8]			
Access			R	R	R	R	R	R
Reset			1	1	q	q	q	q
Bit	7	6	5	4	3	2	1	0
	DEV[7:0]							
Access	R	R	R	R	R	R	R	R
Reset	q	q	q	q	q	q	q	q

Bit 13 - Reserved Reserved - Read as '1'

Bit 12 - Reserved Reserved - Read as '1'

Bits 11:0 - DEV[11:0] Device ID

Device	Device ID
PIC16F18126	3111h
PIC16F18146	3112h

8.7.2 Revision ID

Name: REVISIONID
Offset: 0x8005

Revision ID Register

Bit	15	14	13	12	11	10	9	8
			Reserved	Reserved	MJRREV[5:2]			
Access			R	R	R	R	R	R
Reset			1	0	q	q	q	q
Bit	7	6	5	4	3	2	1	0
	MJRREV[1:0]		MNRREV[5:0]					
Access	R	R	R	R	R	R	R	R
Reset	q	q	q	q	q	q	q	q

Bit 13 - Reserved Reserved - Read as '1'

Bit 12 - Reserved Reserved - Read as '0'

Bits 11:6 - MJRREV[5:0] Major Revision ID

These bits are used to identify a major revision (A0, B0, C0, etc.).

Bits 5:0 - MNRREV[5:0] Minor Revision ID

These bits are used to identify a minor revision.

9. Memory Organization

There are three types of memory in PIC16F181 microcontroller devices:

- Program Memory
 - Program Flash Memory
 - Configuration Words
 - Device ID
 - Revision ID
 - User ID
 - Device Information Area (DIA)
 - Device Configuration Information (DCI)
- Data Memory
 - Core Registers
 - Special Function Registers (FSR)
 - General Purpose RAM (GPR)
 - Common RAM
- Data EEPROM

In Harvard architecture devices, the data and program memories use separate buses that allow for concurrent access of the two memory spaces. The data EEPROM, for practical purposes, can be regarded as a peripheral device, since it is addressed and accessed through a set of control registers.

Additional detailed information on the operation of the Program Flash Memory and data EEPROM memory is provided in the **“NVM - Nonvolatile Memory Control”** chapter.

9.1 Program Memory Organization

The enhanced mid-range core has a 15-bit Program Counter capable of addressing 32K x 14 program memory space. The table below shows the memory sizes implemented. Accessing a location above these boundaries will cause a wrap-around within the implemented memory space.

The Reset vector is at 0000h and the interrupt vector is at 0004h. Refer to the **“INT - Interrupts”** chapter for more details.

Table 9-1. Device Sizes and Addresses

Device	Program Memory Size (Words)	Last Program Memory Address
PIC16F18126	16,384	3FFFh
PIC16F18146	16,384	3FFFh

Figure 9-1. Program Memory and Stack (PIC16F181x6)

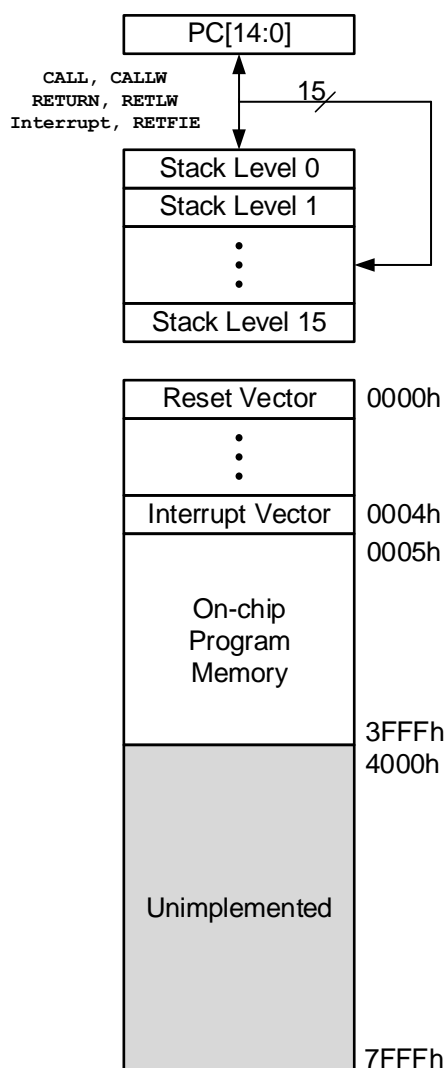

9.1.1 Reading Program Memory as Data

There are three methods of accessing constants in program memory. The first method is to use tables of `RETLW` instructions, the second is to set an FSR to point to the program memory, and the third is to use the NVMREG interface to access the program memory.

9.1.1.1 RETLW Instruction

The `RETLW` instruction can be used to provide access to tables of constants. The recommended way to create such a table is shown in the following example.

Example 9-1. Accessing Table of Constants Using the `RETLW` Instruction

```
constants
BRW                ;Add Index in W to
                   ;program counter to
                   ;select data
```

```

RETLW DATA0          ;Index0 data
RETLW DATA1          ;Index1 data
RETLW DATA2
RETLW DATA3
my_function
;LOTS OF CODE....
MOVLW      DATA_INDEX
call constants
;THE CONSTANT IS IN W

```

The `BRW` instruction eases the implementation of this type of table.

9.1.1.2 Indirect Read with FSR

The program memory can be accessed as data by setting bit 7 of an `FSRxH` register and reading the matching `INDFx` register. The `MOVIW` instruction will place the lower eight bits of the addressed word in the `W` register. Writes to the program memory cannot be performed via the `INDFx` registers. Instructions that read the program memory via the FSR require one extra instruction cycle to complete. The following example demonstrates reading the program memory via an FSR.

The high directive will set bit 7 if a label points to a location in the program memory. This applies to the assembly code shown below.

Example 9-2. Read of Program Memory Using FSR Register

```

constants
RETLW DATA0          ;Index0 data
RETLW DATA1          ;Index1 data
RETLW DATA2
RETLW DATA3
my_function
;LOTS OF CODE....
MOVLW      LOW constants
MOVWF      FSR1L
MOVLW      HIGH constants
MOVWF      FSR1H
MOVIW      2[FSR1]      ;DATA2 IS IN W

```

9.1.2 Memory Access Partition (MAP)

User Flash is partitioned into:

- Application Block
- Boot Block
- Storage Area Flash (SAF) Block

The user can allocate the memory usage by setting the `BBEN` bit, selecting the size of the partition defined by `BBSIZE` bits and enabling the Storage Area Flash by the `SAFEN` bit.

9.1.2.1 Application Block

Default settings of the Configuration bits (`BBEN` = 1 and `SAFEN` = 1) assign all memory in the user Flash area to the application block.

9.1.2.2 Boot Block

If `BBEN` = 1, the Boot Block is enabled and a specific address range is allotted as the Boot Block, based on the value of the `BBSIZE` bits.

9.1.2.3 Storage Area Flash

Storage Area Flash (SAF) is enabled by clearing the `SAFEN` bit. If enabled, the SAF block is placed at the end of memory and spans 128 words. If the Storage Area Flash (SAF) is enabled, the SAF area is not available for program execution.



Important: Storage Area Flash, when enabled, may be used to store variables or other information, often in devices without EEPROM; however, the SAF is accessed in the same manner as other Flash memory areas.

9.1.2.4 Memory Write Protection

All the memory blocks have corresponding write protection bits (\overline{WRTAPP} , \overline{WRTB} , \overline{WRTC} , \overline{WRTD} , and \overline{WRTSAF}). If write-protected locations are written from NVMCON registers, the memory is not changed and the WRERR bit of the NVMCON1 register is set as explained in the “**WRERR Bit**” section from the “**NVM - Nonvolatile Memory Control**” chapter.

9.1.2.5 Memory Violation

A Memory Execution Violation Reset occurs while executing an instruction that has been fetched from outside a valid execution area, clearing the MEMV bit. Refer to the “**Memory Execution Violation**” section in the “**Resets**” chapter for the available valid program execution areas and the PCON1 register definition for MEMV bit conditions.

Table 9-2. Memory Access Partition

REG	Address	Partition			
		$\overline{BBEN} = 1$ $\overline{SAFEN} = 1$	$\overline{BBEN} = 1$ $\overline{SAFEN} = 0$	$\overline{BBEN} = 0$ $\overline{SAFEN} = 1$	$\overline{BBEN} = 0$ $\overline{SAFEN} = 0$
PFM	00 0000h ... Last Block Memory Address	Application Block ⁽⁴⁾	Application Block ⁽⁴⁾	Boot Block ⁽⁴⁾	Boot Block ⁽⁴⁾
	Last Boot Block Memory Address + 1 ⁽¹⁾ ... Last Program Memory Address - 80h			Application Block ⁽⁴⁾	Application Block ⁽⁴⁾
	Last Program Memory Address - 7Fh ⁽²⁾ ... Last Program Memory Address		SAF ⁽⁴⁾	SAF ⁽⁴⁾	
CONFIG	Config Memory Address ⁽³⁾	CONFIG			
EEPROM	F000h-F0FFh	EEPROM			

Notes:

1. Last Boot Block Memory Address is based on the BBSIZE Configuration bits.
2. Last Program Memory Address is shown in the Device Sizes and Addresses table.
3. Config Memory Address are the address locations of the Configuration Words given in the “**NVMREG Access to DIA, DCI, User ID, DEV/REV ID, and Configuration Words**” section in the “**NVM - Nonvolatile Memory Control**” chapter.
4. Each memory block has a corresponding write protection fuse defined by the \overline{WRTAPP} , \overline{WRTB} , \overline{WRTC} , \overline{WRTD} , and \overline{WRTSAF} Configuration bits.

9.1.3 Device Information Area (DIA)

The Device Information Area (DIA) is a dedicated region in the Program Flash Memory. The data are mapped from address 8100h to 813Fh. These locations are read-only and cannot be erased or modified. The DIA contains the Microchip Unique Identifier words, Temperature Indicator range data, and the Fixed Voltage Reference (FVR) voltage readings in millivolts (mV). The [DIA Table](#) holds the DIA information for the PIC16F181 family of microcontrollers.

Table 9-3. Device Information Area

Address Range	Name of Region	Standard Device Information
8100h - 8108h	MUI0	Microchip Unique Identifier (9 Words)
	MUI1	
	MUI2	
	MUI3	
	MUI4	
	MUI5	
	MUI6	
	MUI7	
	MUI8	
8109h	MUI9	Reserved (1 Word)
810Ah - 8111h	EUI0	Optional External Unique Identifier (8 Words)
	EUI1	
	EUI2	
	EUI3	
	EUI4	
	EUI5	
	EUI6	
	EUI7	
8112h	TSLR1 ⁽¹⁾	Gain = $\frac{0.1C \times 256}{count}$ (low range setting)
8113h	TSLR2 ⁽¹⁾	Temperature sensor ADC reading at 90°C (low range setting)
8114h	TSLR3 ⁽¹⁾	Offset (low range setting)
8115h	TSHR1 ⁽²⁾	Gain = $\frac{0.1C \times 256}{count}$ (high range setting)
8116h	TSHR2 ⁽²⁾	Temperature sensor ADC reading at 90°C (high range setting)
8117h	TSHR3 ⁽²⁾	Offset (high range setting)
8118h	FVRA1X	ADC FVR1 output voltage for 1x setting (in mV)
8119h	FVRA2X	ADC FVR1 output voltage for 2x setting (in mV)
811Ah	FVRA4X	ADC FVR1 output voltage for 4x setting (in mV)
811Bh	FVRC1X	Comparator FVR2 output voltage for 1x setting (in mV)
811Ch	FVRC2X	Comparator FVR2 output voltage for 2x setting (in mV)
811Dh	FVRC4X	Comparator FVR2 output voltage for 4x setting (in mV)
811Eh - 811Fh	Reserved	Reserved (2 Words)

Notes:

1. TSLR: Addresses 8112h - 8114h store the measurements for the low range setting of the temperature sensor at $V_{DD} = 3.0V$, $V_{REF+} = 2.048V$ from FVR1.
2. TSHR: Addresses 8115h - 8117h store the measurements for the high range setting of the temperature sensor at $V_{DD} = 3.0V$, $V_{REF+} = 2.048V$ from FVR1.

9.1.3.1 Microchip Unique Identifier (MUI)

The PIC16F181 devices are individually encoded during final manufacturing with a Microchip Unique Identifier (MUI). The MUI cannot be erased by a Bulk Erase command or any other user-accessible means. This feature allows for manufacturing traceability of Microchip Technology devices in applications where this is required. It may also be used by the application manufacturer for a number of functions that require unverified unique identification, such as:

- Tracking the device

- Unique serial number

The MUI consists of nine program words. When taken together, these fields form a unique identifier. The MUI is stored in read-only locations, located between 8100h to 8108h in the DIA space. The DIA Table lists the addresses of the identifier words.



Important: For applications requiring verified unique identification, contact the Microchip Technology sales office to create a serialized quick turn programming option.

9.1.3.2 External Unique Identifier (EUI)

The EUI data are stored at locations 810Ah to 8111h in the program memory region. This region is an optional space for placing application specific information. The data are coded per customer requirements during manufacturing. The EUI cannot be erased by a Bulk Erase command.



Important: Data are stored in this address range on receiving a request from the customer. The customer may contact the local sales representative or Field Applications Engineer and provide them with the unique identifier information that is required to be stored in this region.

9.1.3.3 Standard Parameters for the Temperature Sensor

The purpose of the temperature indicator module is to provide a temperature-dependent voltage that can be measured by an analog module. The [DIA Table](#) contains standard parameters for the temperature sensor for low and high range. The values are measured during test and are unique to each device. The calibration data can be used to plot the approximate sensor output voltage, V_{TSENSE} vs. Temperature curve. The **“Temperature Indicator Module”** chapter explains the operation of the Temperature Indicator module and defines terms such as the low range and high range settings of the sensor.

9.1.3.4 Fixed Voltage Reference Data

The Fixed Voltage Reference (FVR) is a stable voltage reference, independent of V_{DD} , with 1.024V, 2.048V or 4.096V selectable output levels. The output of the FVR can be configured to supply a reference voltage to the following:

- ADC input channel
- ADC positive reference
- Comparator positive input
- Digital-to-Analog Converter (DAC)

For more information on the FVR, refer to the **“FVR - Fixed Voltage Reference”** chapter.

The DIA stores measured FVR voltages for this device in mV for the different buffer settings of 1x, 2x or 4x.

- FVRA1X stores the value of ADC FVR1 Output Voltage for 1x setting (in mV)
- FVRA2X stores the value of ADC FVR1 Output Voltage for 2x setting (in mV)
- FVRA4X stores the value of ADC FVR1 Output Voltage for 4x setting (in mV)
- FVRC1X stores the value of Comparator FVR2 Output Voltage for 1x setting (in mV)
- FVRC2X stores the value of Comparator FVR2 Output Voltage for 2x setting (in mV)
- FVRC4X stores the value of Comparator FVR2 Output Voltage for 4x setting (in mV)

9.1.4 Device Configuration Information (DCI)

The Device Configuration Information (DCI) is a dedicated region in the memory that holds information about the device, which is useful for programming and bootloader applications. The data stored in this region is read-only and cannot be modified/erased. Refer to the table below for complete DCI table addresses and description.

Table 9-4. Device Configuration Information

Address	Name	Description	Value		Units
			PIC16F18126	PIC16F18146	
8200h	ERSIZ	Erase Row Size	32		Words
8201h	WLSIZ	Number of write latches per row	32		Words
8202h	URSIZ	Number of user erasable rows	512		Rows
8203h	EESIZ	Data EEPROM memory size	256		Bytes
8204h	PCNT	Pin Count	14/20		Pins

9.1.4.1 DIA and DCI Access

The DIA and DCI data are read-only and cannot be erased or modified. See the **“NVMREG Access to DIA, DCI, User ID, DEV/REV ID, and Configuration Words”** section in the **“NVM - Nonvolatile Memory Control”** chapter for more information on accessing these memory locations.

Development tools, such as device programmers and debuggers, may be used to read the DIA and DCI regions, similar to the Device ID and Revision ID.

9.2 Data Memory Organization

The data memory is partitioned into up to 64 memory banks with 128 bytes in each bank. Each bank consists of:

- 12 core registers
- Up to 20 Special Function Registers (SFR)
- Up to 80 bytes of General Purpose RAM (GPR)
- 16 bytes of common RAM

Figure 9-2. Banked Memory Partition

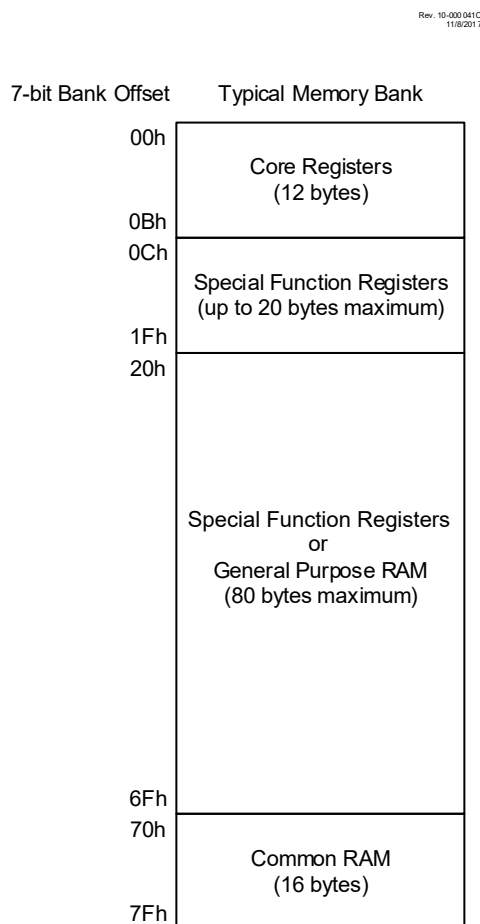

9.2.1 Bank Selection

The active bank is selected by writing the bank number into the Bank Select Register (BSR). All data memory can be accessed either directly via instructions that use the file registers or indirectly via the two File Select Registers (FSRs). Data memory uses a 13-bit address. The upper six bits of the address define the Bank Address and the lower seven bits select the registers/RAM in that bank.

9.2.2 Core Registers

The core registers contain the registers that directly affect the basic operation. The core registers occupy the first 12 addresses of every data memory bank. These registers are listed in the [Core Registers](#) table below.

Table 9-5. Core Registers

Addresses in BANKx	Core Registers
x00h or x80h	INDF0
x01h or x81h	INDF1
x02h or x82h	PCL
x03h or x83h	STATUS
x04h or x84h	FSR0L
x05h or x85h	FSR0H

.....continued

Addresses in BANKx	Core Registers
x06h or x86h	FSR1L
x07h or x87h	FSR1H
x08h or x88h	BSR
x09h or x89h	WREG
x0Ah or x8Ah	PCLATH
x0Bh or x8Bh	INTCON

9.2.3 Special Function Register

The Special Function Registers (SFR) are registers used by the application to control the desired operation of peripheral functions in the device. The SFRs occupy the first 20 bytes of the data banks 0-59 and the first 100 bytes of the data banks 60-63, after the core registers.

The SFRs associated with the operation of the peripherals are described in the appropriate peripheral chapter of this data sheet.

9.2.4 General Purpose RAM

There are up to 80 bytes of GPR in each data memory bank. The general purpose RAM can be accessed in a non-banked method via the FSRs. This can simplify access to large memory structures.

Refer to the “**Linear Data Memory**” section in the “**Memory Organization**” chapter for details about linear memory accessing.

9.2.5 Common RAM

There are 16 bytes of common RAM accessible from all banks.

9.2.6 Device Memory Maps

The memory maps for the devices in this data sheet are listed in the following figures.

Figure 9-3. Memory Map Banks 0 - 7

BANK 0		BANK 1		BANK 2		BANK 3		BANK 4		BANK 5		BANK 6		BANK 7	
000h	Core Registers	080h	Core Registers	100h	Core Registers	180h	Core Registers	200h	Core Registers	280h	Core Registers	300h	Core Registers	380h	Core Registers
008h	—	088h	PIR0	108h	PMD0	188h	WDTC0N0	208h	FVRCON	288h	CPUDOZE	308h	TMR1L	388h	T2TMR
00Ch	PORTA	08Ch	PIR0	10Ch	PMD0	18Ch	WDTC0N0	20Ch	CPCON	28Ch	OSCCON1	30Ch	TMR1H	38Ch	T2PR
00Dh	PORTB ⁽¹⁾	08Dh	PIR1	10Dh	PMD1	18Dh	WDTC0N1	20Dh	—	28Dh	OSCCON2	30Eh	T1CON	38Eh	T2CON
00Eh	—	08Eh	PIR2	10Eh	PMD2	18Eh	WDTPSL	20Eh	—	28Eh	OSCCON3	30Fh	T1GCON	38Fh	T2HLT
00Fh	—	08Fh	PIR3	10Fh	PMD3	18Fh	WDTPSH	20Fh	—	28Fh	OSCCON3	310h	T1GATE	390h	T2CLK
010h	—	090h	PIR4	110h	PMD4	190h	WDTTMR	210h	—	290h	OSCCON3	311h	T1CLK	391h	T2RST
011h	—	091h	PIR5	111h	—	191h	BORCON	211h	—	291h	OSCTUNE	312h	TMR3L	392h	T4TMR
012h	TRISA	092h	PIR6	112h	—	192h	PCON0	212h	—	292h	OSCFRQ	313h	TMR3H	393h	T4PR
013h	TRISB ⁽¹⁾	093h	—	113h	—	193h	PCON1	213h	—	293h	ACTCON	314h	T3CON	394h	T4CON
014h	TRISC	094h	—	114h	—	194h	—	214h	—	294h	—	315h	T3GCON	395h	T4HLT
015h	—	095h	—	115h	—	195h	—	215h	—	295h	—	316h	T3GATE	396h	T4CLK
016h	—	096h	PIE0	116h	—	196h	—	216h	—	296h	CLKRCON	317h	T3CLK	397h	T4RST
017h	—	097h	PIE1	117h	—	197h	—	217h	—	297h	CLKRCLK	318h	—	398h	—
018h	LATA	098h	PIE2	118h	—	198h	—	218h	—	298h	—	319h	—	399h	—
019h	LATB ⁽¹⁾	099h	PIE3	119h	—	199h	—	219h	—	299h	—	320h	—	300h	—
01Ah	LATC	09Ah	PIE4	11Ah	—	19Ah	—	21Ah	—	29Ah	—	320h	—	300h	—
01Bh	—	09Bh	PIE5	11Bh	—	19Bh	—	21Bh	—	29Bh	—	320h	—	300h	—
01Ch	—	09Ch	PIE6	11Ch	—	19Ch	TMR0L	21Ch	—	29Ch	—	320h	—	300h	—
01Dh	—	09Dh	—	11Dh	—	19Dh	TRMOH	21Dh	—	29Dh	—	320h	—	300h	—
01Eh	—	09Eh	—	11Eh	—	19Eh	TOCON0	21Eh	—	29Eh	—	320h	—	300h	—
01Fh	—	09Fh	—	11Fh	—	19Fh	TOCON1	21Fh	ZDCCON	29Fh	—	320h	—	300h	—
020h	—	0A0h	—	120h	—	1A0h	—	220h	—	2A0h	—	320h	—	3A0h	—
06Fh	General Purpose Registers 80 Bytes	06Fh	General Purpose Registers 80 Bytes	16Fh	General Purpose Registers 80 Bytes	16Fh	General Purpose Registers 80 Bytes	26Fh	General Purpose Registers 80 Bytes	26Fh	General Purpose Registers 80 Bytes	26Fh	General Purpose Registers 80 Bytes	36Fh	General Purpose Registers 80 Bytes
070h	Common RAM (Accesses 70h-7Fh)	0F0h	Common RAM (Accesses 70h-7Fh)	170h	Common RAM (Accesses 70h-7Fh)	1F0h	Common RAM (Accesses 70h-7Fh)	270h	Common RAM (Accesses 70h-7Fh)	2F0h	Common RAM (Accesses 70h-7Fh)	370h	Common RAM (Accesses 70h-7Fh)	3F0h	Common RAM (Accesses 70h-7Fh)
07Fh	—	0Fh	—	17Fh	—	1Fh	—	27Fh	—	2Fh	—	37Fh	—	3Fh	—

Note: 1. Available on 20-pin devices only.
Legend: Unimplemented data memory locations, read as '0'.

Figure 9-4. Memory Map Banks 8 - 15

BANK 8		BANK 9		BANK 10		BANK 11		BANK 12		BANK 13		BANK 14		BANK 15	
400h	Core Registers	480h	Core Registers	500h	Core Registers	580h	Core Registers	600h	Core Registers	680h	Core Registers	700h	Core Registers	780h	Core Registers
40Bh		48Bh		50Bh		58Bh		60Bh		68Bh		70Bh		78Bh	
40Ch	CCPR1L	48Ch	PWM1ERS	50Ch	PWM2ERS	58Ch	NCO1ACCL	60Ch	CWG1CLK	68Ch	CLCnCON	70Ch	RC1REG	78Ch	SSP1BUF
40Dh	CCPR1H	48Dh	PWM1CLK	50Dh	PWM2CLK	58Dh	NCO1ACCH	60Dh	CWG1ISM	68Dh	CLCnPOL	70Dh	TX1REG	78Dh	SSP1ADD
40Eh	CCP1CON	48Eh	PWM1LDS	50Eh	PWM2LDS	58Eh	NCO1ACCU	60Eh	CWG1DBR	68Eh	CLCnSELO	70Eh	SP1GRBL	78Eh	SSP1MSK
40Fh	CCP1CAP	48Fh	PWM1PRL	50Fh	PWM2PRL	58Fh	NCO1INCL	60Fh	CWG1DBF	68Fh	CLCnSEL1	70Fh	SP1BRGH	78Fh	SSP1STAT
410h	CCPR2L	490h	PWM1PRH	510h	PWM2PRH	590h	NCO1INCH	610h	CWG1CON0	690h	CLCnSEL2	710h	RC1STA	790h	SSP1CON1
411h	CCPR2H	491h	PWM1CPRE	511h	PWM2CPRE	591h	NCO1INCU	611h	CWG1CON1	691h	CLCnSEL3	711h	TX1STA	791h	SSP1CON2
412h	CCP2CON	492h	PWM1PIPOS	512h	PWM2PIPOS	592h	NCO1CON	612h	CWG1AS0	692h	CLCnGLS0	712h	BAUD1CON	792h	SSP1CON3
413h	CCP2CAP	493h	PWM1GIR	513h	PWM2GIR	593h	NCO1CLK	613h	CWG1AS1	693h	CLCnGLS1	713h	—	793h	—
414h	—	494h	PWM1GIE	514h	PWM2GIE	594h	—	614h	CWG1STR	694h	CLCnGLS2	714h	—	794h	—
415h	—	495h	PWM1CON	515h	PWM2CON	595h	—	615h	—	695h	CLCnGLS3	715h	—	795h	—
416h	—	496h	PWM1S1CFG	516h	PWM2S1CFG	596h	—	616h	—	696h	CLCSELECT	716h	RC2REG	796h	SSP2BUF
417h	—	497h	PWM1S1P1L	517h	PWM2S1P1L	597h	—	617h	—	697h	CLCDATA	717h	TX2REG	797h	SSP2ADD
418h	—	498h	PWM1S1P1H	518h	PWM2S1P1H	598h	—	618h	—	698h	—	718h	SP2GRBL	798h	SSP2MSK
419h	—	499h	PWM1S1P2L	519h	PWM2S1P2L	599h	—	619h	—	699h	—	719h	SP2BRGH	799h	SSP2STAT
41Ah	—	49Ah	PWM1S1P2H	51Ah	PWM2S1P2H	59Ah	—	61Ah	—	69Ah	—	71Ah	RC2STA	79Ah	SSP2CON1
41Bh	—	49Bh	—	51Bh	—	59Bh	—	61Bh	—	69Bh	—	71Bh	TX2STA	79Bh	SSP2CON2
41Ch	—	49Ch	—	51Ch	—	59Ch	—	61Ch	—	69Ch	—	71Ch	BAUD2CON	79Ch	SSP2CON3
41Dh	—	49Dh	—	51Dh	—	59Dh	—	61Dh	—	69Dh	—	71Dh	—	79Dh	—
41Eh	—	49Eh	PWMLoad	51Eh	—	59Eh	—	61Eh	—	69Eh	—	71Eh	—	79Eh	—
41Fh	CCPTMR50	49Fh	PWMEN	51Fh	—	59Fh	—	61Fh	—	69Fh	—	71Fh	—	79Fh	—
420h	General Purpose Registers 80 Bytes	4A0h	General Purpose Registers 80 Bytes	520h	General Purpose Registers 80 Bytes	5A0h	General Purpose Registers 80 Bytes	620h	General Purpose Registers 80 Bytes	6A0h	General Purpose Registers 80 Bytes	720h	General Purpose Registers 80 Bytes	7A0h	General Purpose Registers 80 Bytes
46Fh	Common RAM (Accesses 70h-7Fh)	4EFh	Common RAM (Accesses 70h-7Fh)	56Fh	Common RAM (Accesses 70h-7Fh)	5EFh	Common RAM (Accesses 70h-7Fh)	66Fh	Common RAM (Accesses 70h-7Fh)	6EFh	Common RAM (Accesses 70h-7Fh)	76Fh	Common RAM (Accesses 70h-7Fh)	7EFh	Common RAM (Accesses 70h-7Fh)
470h		4F0h		570h		5F0h		670h		6F0h		770h		7F0h	
47Fh		4Fh		57Fh		5Fh		67Fh		6Fh		77Fh		7Fh	

Legend:
 Unimplemented data memory locations, read as '0'.

Figure 9-5. Memory Map Banks 16 - 23

BANK 16		BANK 17		BANK 18		BANK 19		BANK 20		BANK 21		BANK 22		BANK 23	
800h	Core Registers	880h	Core Registers	900h	Core Registers	980h	Core Registers	A00h	Core Registers	A80h	Core Registers	B00h	Core Registers	B80h	Core Registers
80Bh		88Bh		90Bh		98Bh		A0Bh		A8Bh		B0Bh		B8Bh	
80Ch	CM1CON0	88Ch	DAC1CON0	90Ch	—	98Ch	—	A0Ch	—	A8Ch	—	B0Ch	—	B8Ch	—
80Dh	CM1CON1	88Dh	DAC1DATL	90Dh	—	98Dh	—	A0Dh	—	A8Dh	—	B0Dh	—	B8Dh	—
80Eh	CM1NCH	88Eh	—	90Eh	—	98Eh	—	A0Eh	—	A8Eh	—	B0Eh	—	B8Eh	—
80Fh	CM1PCH	88Fh	—	90Fh	—	98Fh	—	A0Fh	—	A8Fh	—	B0Fh	—	B8Fh	—
810h	CM2CON0	890h	DAC2CON0	910h	—	990h	—	A10h	—	A90h	—	B10h	—	B90h	—
811h	CM2CON1	891h	DAC2DATL	911h	—	991h	—	A11h	—	A91h	—	B11h	—	B91h	—
812h	CM2NCH	892h	—	912h	—	992h	—	A12h	—	A92h	—	B12h	—	B92h	—
813h	CM2PCH	893h	—	913h	—	993h	—	A13h	—	A93h	—	B13h	—	B93h	—
814h	—	894h	—	914h	—	994h	—	A14h	—	A94h	—	B14h	—	B94h	—
815h	—	895h	—	915h	—	995h	—	A15h	—	A95h	—	B15h	—	B95h	—
816h	—	896h	—	916h	—	996h	—	A16h	—	A96h	—	B16h	—	B96h	—
817h	—	897h	—	917h	—	997h	—	A17h	—	A97h	—	B17h	—	B97h	—
818h	—	898h	—	918h	—	998h	—	A18h	—	A98h	—	B18h	—	B98h	—
819h	—	899h	—	919h	—	999h	—	A19h	—	A99h	—	B19h	—	B99h	—
81Ah	—	89Ah	—	91Ah	—	99Ah	—	A1Ah	—	A9Ah	—	B1Ah	—	B9Ah	—
81Bh	—	89Bh	—	91Bh	—	99Bh	—	A1Bh	—	A9Bh	—	B1Bh	—	B9Bh	—
81Ch	—	89Ch	—	91Ch	—	99Ch	—	A1Ch	—	A9Ch	—	B1Ch	—	B9Ch	—
81Dh	—	89Dh	—	91Dh	—	99Dh	—	A1Dh	—	A9Dh	—	B1Dh	—	B9Dh	—
81Eh	—	89Eh	—	91Eh	—	99Eh	—	A1Eh	—	A9Eh	—	B1Eh	—	B9Eh	—
81Fh	CMOUT	89Fh	—	91Fh	—	99Fh	—	A1Fh	—	A9Fh	—	B1Fh	—	B9Fh	—
820h	General Purpose Registers 80 Bytes	8A0h	General Purpose Registers 80 Bytes	920h	General Purpose Registers 80 Bytes	9A0h	General Purpose Registers 80 Bytes	A20h	General Purpose Registers 80 Bytes	AA0h	General Purpose Registers 80 Bytes	B20h	General Purpose Registers 80 Bytes	BA0h	General Purpose Registers 80 Bytes
86Fh	Common RAM (Accesses 70h-7Fh)	8EFh	Common RAM (Accesses 70h-7Fh)	96Fh	Common RAM (Accesses 70h-7Fh)	9EFh	Common RAM (Accesses 70h-7Fh)	A6Fh	Common RAM (Accesses 70h-7Fh)	AEFh	Common RAM (Accesses 70h-7Fh)	B6Fh	Common RAM (Accesses 70h-7Fh)	BEFh	Common RAM (Accesses 70h-7Fh)
870h		8F0h		970h		9F0h		A70h		AF0h		B70h		BF0h	
87Fh		8Fh		97Fh		9Fh		A7Fh		AFh		B7Fh		BFh	

Legend:
 Unimplemented data memory locations, read as '0'.

Figure 9-6. Memory Map Banks 24 - 31

BANK 24		BANK 25		BANK 26		BANK 27		BANK 28		BANK 29		BANK 30		BANK 31	
C00h	Core Registers	C80h	Core Registers	D00h	Core Registers	D80h	Core Registers	E00h	Core Registers	E80h	Core Registers	F00h	Core Registers	F80h	Core Registers
C08h	—	C88h	—	D08h	—	D88h	—	E08h	—	E88h	—	F08h	—	F88h	—
C0Ch	—	C8Ch	—	D0Ch	—	D8Ch	—	E0Ch	—	E8Ch	—	F0Ch	—	F8Ch	—
C0Dh	—	C8Dh	—	D0Dh	—	D8Dh	—	E0Dh	—	E8Dh	—	F0Dh	—	F8Dh	—
C0Eh	—	C8Eh	—	D0Eh	—	D8Eh	—	E0Eh	—	E8Eh	—	F0Eh	—	F8Eh	—
C0Fh	—	C8Fh	—	D0Fh	—	D8Fh	—	E0Fh	—	E8Fh	—	F0Fh	—	F8Fh	—
C10h	—	C90h	—	D10h	—	D90h	—	E10h	—	E90h	—	F10h	—	F90h	—
C11h	—	C91h	—	D11h	—	D91h	—	E11h	—	E91h	—	F11h	—	F91h	—
C12h	—	C92h	—	D12h	—	D92h	—	E12h	—	E92h	—	F12h	—	F92h	—
C13h	—	C93h	—	D13h	—	D93h	—	E13h	—	E93h	—	F13h	—	F93h	—
C14h	—	C94h	—	D14h	—	D94h	—	E14h	—	E94h	—	F14h	—	F94h	—
C15h	—	C95h	—	D15h	—	D95h	—	E15h	—	E95h	—	F15h	—	F95h	—
C16h	—	C96h	—	D16h	—	D96h	—	E16h	—	E96h	—	F16h	—	F96h	—
C17h	—	C97h	—	D17h	—	D97h	—	E17h	—	E97h	—	F17h	—	F97h	—
C18h	—	C98h	—	D18h	—	D98h	—	E18h	—	E98h	—	F18h	—	F98h	—
C19h	—	C99h	—	D19h	—	D99h	—	E19h	—	E99h	—	F19h	—	F99h	—
C1Ah	—	C9Ah	—	D1Ah	—	D9Ah	—	E1Ah	—	E9Ah	—	F1Ah	—	F9Ah	—
C1Bh	—	C9Bh	—	D1Bh	—	D9Bh	—	E1Bh	—	E9Bh	—	F1Bh	—	F9Bh	—
C1Ch	—	C9Ch	—	D1Ch	—	D9Ch	—	E1Ch	—	E9Ch	—	F1Ch	—	F9Ch	—
C1Dh	—	C9Dh	—	D1Dh	—	D9Dh	—	E1Dh	—	E9Dh	—	F1Dh	—	F9Dh	—
C1Eh	—	C9Eh	—	D1Eh	—	D9Eh	—	E1Eh	—	E9Eh	—	F1Eh	—	F9Eh	—
C1Fh	—	C9Fh	—	D1Fh	—	D9Fh	—	E1Fh	—	E9Fh	—	F1Fh	—	F9Fh	—
C20h	General Purpose Registers 80 Bytes	CA0h	General Purpose Registers 32 Bytes	D20h	Unimplemented Read as '0'	DA0h	Unimplemented Read as '0'	E20h	Unimplemented Read as '0'	EA0h	Unimplemented Read as '0'	FA0h	Unimplemented Read as '0'	FA0h	Unimplemented Read as '0'
C6Fh	—	CBFh	Unimplemented Read as '0'	D6Fh	—	DAFh	—	E6Fh	—	EAFh	—	FAFh	—	FAFh	—
C70h	Common RAM (Accesses 70h-7Fh)	CF0h	Common RAM (Accesses 70h-7Fh)	D70h	Common RAM (Accesses 70h-7Fh)	DF0h	Common RAM (Accesses 70h-7Fh)	E70h	Common RAM (Accesses 70h-7Fh)	EF0h	Common RAM (Accesses 70h-7Fh)	FF0h	Common RAM (Accesses 70h-7Fh)	FF0h	Common RAM (Accesses 70h-7Fh)
C7Fh	—	CFh	—	D7Fh	—	DFh	—	E7Fh	—	EFh	—	FFh	—	FFh	—

Legend:
 Unimplemented data memory locations, read as '0'.

Figure 9-7. Memory Map Banks 32 - 39

BANK 32		BANK 33		BANK 34		BANK 35		BANK 36		BANK 37		BANK 38		BANK 39	
1000h	Core Registers	1080h	Core Registers	1100h	Core Registers	1180h	Core Registers	1200h	Core Registers	1280h	Core Registers	1300h	Core Registers	1380h	Core Registers
1008h	—	1088h	—	1108h	—	1188h	—	1208h	—	1288h	—	1308h	—	1388h	—
100Ch	—	108Ch	—	110Ch	—	118Ch	—	120Ch	—	128Ch	—	130Ch	—	138Ch	—
100Dh	—	108Dh	—	110Dh	—	118Dh	—	120Dh	—	128Dh	—	130Dh	—	138Dh	—
100Eh	—	108Eh	—	110Eh	—	118Eh	—	120Eh	—	128Eh	—	130Eh	—	138Eh	—
100Fh	—	108Fh	—	110Fh	—	118Fh	—	120Fh	—	128Fh	—	130Fh	—	138Fh	—
1010h	—	1090h	—	1110h	—	1190h	—	1210h	—	1290h	—	1310h	—	1390h	—
1011h	—	1091h	—	1111h	—	1191h	—	1211h	—	1291h	—	1311h	—	1391h	—
1012h	—	1092h	—	1112h	—	1192h	—	1212h	—	1292h	—	1312h	—	1392h	—
1013h	—	1093h	—	1113h	—	1193h	—	1213h	—	1293h	—	1313h	—	1393h	—
1014h	—	1094h	—	1114h	—	1194h	—	1214h	—	1294h	—	1314h	—	1394h	—
1015h	—	1095h	—	1115h	—	1195h	—	1215h	—	1295h	—	1315h	—	1395h	—
1016h	—	1096h	—	1116h	—	1196h	—	1216h	—	1296h	—	1316h	—	1396h	—
1017h	—	1097h	—	1117h	—	1197h	—	1217h	—	1297h	—	1317h	—	1397h	—
1018h	—	1098h	—	1118h	—	1198h	—	1218h	—	1298h	—	1318h	—	1398h	—
1019h	—	1099h	—	1119h	—	1199h	—	1219h	—	1299h	—	1319h	—	1399h	—
101Ah	—	109Ah	—	111Ah	—	119Ah	—	121Ah	—	129Ah	—	131Ah	—	139Ah	—
101Bh	—	109Bh	—	111Bh	—	119Bh	—	121Bh	—	129Bh	—	131Bh	—	139Bh	—
101Ch	—	109Ch	—	111Ch	—	119Ch	—	121Ch	—	129Ch	—	131Ch	—	139Ch	—
101Dh	—	109Dh	—	111Dh	—	119Dh	—	121Dh	—	129Dh	—	131Dh	—	139Dh	—
101Eh	—	109Eh	—	111Eh	—	119Eh	—	121Eh	—	129Eh	—	131Eh	—	139Eh	—
101Fh	—	109Fh	—	111Fh	—	119Fh	—	121Fh	—	129Fh	—	131Fh	—	139Fh	—
1020h	Unimplemented Read as '0'	10A0h	Unimplemented Read as '0'	1120h	Unimplemented Read as '0'	11A0h	Unimplemented Read as '0'	1220h	Unimplemented Read as '0'	12A0h	Unimplemented Read as '0'	1320h	Unimplemented Read as '0'	13A0h	Unimplemented Read as '0'
106Fh	—	10EFh	—	116Fh	—	11EFh	—	126Fh	—	12EFh	—	136Fh	—	13EFh	—
1070h	Common RAM (Accesses 70h-7Fh)	10F0h	Common RAM (Accesses 70h-7Fh)	1170h	Common RAM (Accesses 70h-7Fh)	11F0h	Common RAM (Accesses 70h-7Fh)	1270h	Common RAM (Accesses 70h-7Fh)	12F0h	Common RAM (Accesses 70h-7Fh)	1370h	Common RAM (Accesses 70h-7Fh)	13F0h	Common RAM (Accesses 70h-7Fh)
107Fh	—	10Fh	—	117Fh	—	11Fh	—	127Fh	—	12Fh	—	137Fh	—	13Fh	—

Legend:
 Unimplemented data memory locations, read as '0'.

Figure 9-8. Memory Map Banks 40 - 47

BANK 40		BANK 41		BANK 42		BANK 43		BANK 44		BANK 45		BANK 46		BANK 47	
1400h	Core Registers	1480h	Core Registers	1500h	Core Registers	1580h	Core Registers	1600h	Core Registers	1680h	Core Registers	1700h	Core Registers	1780h	Core Registers
140Bh	—	148Bh	—	150Bh	—	158Bh	—	160Bh	—	168Bh	—	170Bh	—	178Bh	—
140Ch	—	148Ch	—	150Ch	—	158Ch	—	160Ch	—	168Ch	—	170Ch	—	178Ch	—
140Dh	—	148Dh	—	150Dh	—	158Dh	—	160Dh	—	168Dh	—	170Dh	—	178Dh	—
140Eh	—	148Eh	—	150Eh	—	158Eh	—	160Eh	—	168Eh	—	170Eh	—	178Eh	—
140Fh	—	148Fh	—	150Fh	—	158Fh	—	160Fh	—	168Fh	—	170Fh	—	178Fh	—
1410h	—	1490h	—	1510h	—	1590h	—	1610h	—	1690h	—	1710h	—	1790h	—
1411h	—	1491h	—	1511h	—	1591h	—	1611h	—	1691h	—	1711h	—	1791h	—
1412h	—	1492h	—	1512h	—	1592h	—	1612h	—	1692h	—	1712h	—	1792h	—
1413h	—	1493h	—	1513h	—	1593h	—	1613h	—	1693h	—	1713h	—	1793h	—
1414h	—	1494h	—	1514h	—	1594h	—	1614h	—	1694h	—	1714h	—	1794h	—
1415h	—	1495h	—	1515h	—	1595h	—	1615h	—	1695h	—	1715h	—	1795h	—
1416h	—	1496h	—	1516h	—	1596h	—	1616h	—	1696h	—	1716h	—	1796h	—
1417h	—	1497h	—	1517h	—	1597h	—	1617h	—	1697h	—	1717h	—	1797h	—
1418h	—	1498h	—	1518h	—	1598h	—	1618h	—	1698h	—	1718h	—	1798h	—
1419h	—	1499h	—	1519h	—	1599h	—	1619h	—	1699h	—	1719h	—	1799h	—
141Ah	—	149Ah	—	151Ah	—	159Ah	—	161Ah	—	169Ah	—	171Ah	—	179Ah	—
141Bh	—	149Bh	—	151Bh	—	159Bh	—	161Bh	—	169Bh	—	171Bh	—	179Bh	—
141Ch	—	149Ch	—	151Ch	—	159Ch	—	161Ch	—	169Ch	—	171Ch	—	179Ch	—
141Dh	—	149Dh	—	151Dh	—	159Dh	—	161Dh	—	169Dh	—	171Dh	—	179Dh	—
141Eh	—	149Eh	—	151Eh	—	159Eh	—	161Eh	—	169Eh	—	171Eh	—	179Eh	—
141Fh	—	149Fh	—	151Fh	—	159Fh	—	161Fh	—	169Fh	—	171Fh	—	179Fh	—
1420h	Unimplemented Read as '0'	14A0h	Unimplemented Read as '0'	1520h	Unimplemented Read as '0'	15A0h	Unimplemented Read as '0'	1620h	Unimplemented Read as '0'	16A0h	Unimplemented Read as '0'	1720h	Unimplemented Read as '0'	17A0h	Unimplemented Read as '0'
146Fh	Common RAM (Accesses 70h-7Fh)	14Fh	Common RAM (Accesses 70h-7Fh)	156Fh	Common RAM (Accesses 70h-7Fh)	15EFh	Common RAM (Accesses 70h-7Fh)	166Fh	Common RAM (Accesses 70h-7Fh)	16EFh	Common RAM (Accesses 70h-7Fh)	176Fh	Common RAM (Accesses 70h-7Fh)	17EFh	Common RAM (Accesses 70h-7Fh)
1470h	Common RAM (Accesses 70h-7Fh)	14F0h	Common RAM (Accesses 70h-7Fh)	1570h	Common RAM (Accesses 70h-7Fh)	15F0h	Common RAM (Accesses 70h-7Fh)	1670h	Common RAM (Accesses 70h-7Fh)	16F0h	Common RAM (Accesses 70h-7Fh)	1770h	Common RAM (Accesses 70h-7Fh)	17F0h	Common RAM (Accesses 70h-7Fh)
147Fh	Common RAM (Accesses 70h-7Fh)	14F7h	Common RAM (Accesses 70h-7Fh)	157Fh	Common RAM (Accesses 70h-7Fh)	15F7h	Common RAM (Accesses 70h-7Fh)	167Fh	Common RAM (Accesses 70h-7Fh)	16F7h	Common RAM (Accesses 70h-7Fh)	177Fh	Common RAM (Accesses 70h-7Fh)	17F7h	Common RAM (Accesses 70h-7Fh)

Legend:
 Unimplemented data memory locations, read as '0'.

Figure 9-9. Memory Map Banks 48 - 55

BANK 48		BANK 49		BANK 50		BANK 51		BANK 52		BANK 53		BANK 54		BANK 55	
1800h	Core Registers	1880h	Core Registers	1900h	Core Registers	1980h	Core Registers	1A00h	Core Registers	1A80h	Core Registers	1B00h	Core Registers	1B80h	Core Registers
180Bh	—	188Bh	—	190Bh	—	198Bh	—	1A0Bh	—	1A8Bh	—	1B0Bh	—	1B8Bh	—
180Ch	—	188Ch	—	190Ch	—	198Ch	—	1A0Ch	—	1A8Ch	—	1B0Ch	—	1B8Ch	—
180Dh	—	188Dh	—	190Dh	—	198Dh	—	1A0Dh	—	1A8Dh	—	1B0Dh	—	1B8Dh	—
180Eh	—	188Eh	—	190Eh	—	198Eh	—	1A0Eh	—	1A8Eh	—	1B0Eh	—	1B8Eh	—
180Fh	—	188Fh	—	190Fh	—	198Fh	—	1A0Fh	—	1A8Fh	—	1B0Fh	—	1B8Fh	—
1810h	—	1890h	—	1910h	—	1990h	—	1A10h	—	1A90h	—	1B10h	—	1B90h	—
1811h	—	1891h	—	1911h	—	1991h	—	1A11h	—	1A91h	—	1B11h	—	1B91h	—
1812h	—	1892h	—	1912h	—	1992h	—	1A12h	—	1A92h	—	1B12h	—	1B92h	—
1813h	—	1893h	—	1913h	—	1993h	—	1A13h	—	1A93h	—	1B13h	—	1B93h	—
1814h	—	1894h	—	1914h	—	1994h	—	1A14h	—	1A94h	—	1B14h	—	1B94h	—
1815h	—	1895h	—	1915h	—	1995h	—	1A15h	—	1A95h	—	1B15h	—	1B95h	—
1816h	—	1896h	—	1916h	—	1996h	—	1A16h	—	1A96h	—	1B16h	—	1B96h	—
1817h	—	1897h	—	1917h	—	1997h	—	1A17h	—	1A97h	—	1B17h	—	1B97h	—
1818h	—	1898h	—	1918h	—	1998h	—	1A18h	—	1A98h	—	1B18h	—	1B98h	—
1819h	—	1899h	—	1919h	—	1999h	—	1A19h	—	1A99h	—	1B19h	—	1B99h	—
181Ah	—	189Ah	—	191Ah	—	199Ah	—	1A1Ah	—	1A9Ah	—	1B1Ah	—	1B9Ah	—
181Bh	—	189Bh	—	191Bh	—	199Bh	—	1A1Bh	—	1A9Bh	—	1B1Bh	—	1B9Bh	—
181Ch	—	189Ch	—	191Ch	—	199Ch	—	1A1Ch	—	1A9Ch	—	1B1Ch	—	1B9Ch	—
181Dh	—	189Dh	—	191Dh	—	199Dh	—	1A1Dh	—	1A9Dh	—	1B1Dh	—	1B9Dh	—
181Eh	—	189Eh	—	191Eh	—	199Eh	—	1A1Eh	—	1A9Eh	—	1B1Eh	—	1B9Eh	—
181Fh	—	189Fh	—	191Fh	—	199Fh	—	1A1Fh	—	1A9Fh	—	1B1Fh	—	1B9Fh	—
1820h	Unimplemented Read as '0'	18A0h	Unimplemented Read as '0'	1920h	Unimplemented Read as '0'	19A0h	Unimplemented Read as '0'	1A20h	Unimplemented Read as '0'	1AA0h	Unimplemented Read as '0'	1B20h	Unimplemented Read as '0'	1BA0h	Unimplemented Read as '0'
186Fh	Common RAM (Accesses 70h-7Fh)	18Fh	Common RAM (Accesses 70h-7Fh)	196Fh	Common RAM (Accesses 70h-7Fh)	19EFh	Common RAM (Accesses 70h-7Fh)	1A6Fh	Common RAM (Accesses 70h-7Fh)	1AEFh	Common RAM (Accesses 70h-7Fh)	1B6Fh	Common RAM (Accesses 70h-7Fh)	1BEFh	Common RAM (Accesses 70h-7Fh)
1870h	Common RAM (Accesses 70h-7Fh)	18F0h	Common RAM (Accesses 70h-7Fh)	1970h	Common RAM (Accesses 70h-7Fh)	19F0h	Common RAM (Accesses 70h-7Fh)	1A70h	Common RAM (Accesses 70h-7Fh)	1AF0h	Common RAM (Accesses 70h-7Fh)	1B70h	Common RAM (Accesses 70h-7Fh)	1BF0h	Common RAM (Accesses 70h-7Fh)
187Fh	Common RAM (Accesses 70h-7Fh)	18F7h	Common RAM (Accesses 70h-7Fh)	197Fh	Common RAM (Accesses 70h-7Fh)	19F7h	Common RAM (Accesses 70h-7Fh)	1A7Fh	Common RAM (Accesses 70h-7Fh)	1AF7h	Common RAM (Accesses 70h-7Fh)	1B7Fh	Common RAM (Accesses 70h-7Fh)	1BF7h	Common RAM (Accesses 70h-7Fh)

Legend:
 Unimplemented data memory locations, read as '0'.

Figure 9-10. Memory Map Banks 56 - 63

BANK 56	BANK 57	BANK 58	BANK 59	BANK 60	BANK 61	BANK 62	BANK 63
1C00h Core Registers	1C80h Core Registers	1000h Core Registers	1D80h Core Registers	1E00h Core Registers	1E80h Core Registers	1F00h Core Registers	1F80h Core Registers
1C0Bh	1C8Ch NVMADL	100Ch ADLTHL	1D88h RA0PPS	1E0Bh	1E88h	1F0Bh UMTOAP	1F8Bh
1C0Ch	1C8Dh NVMADH	100Dh ADLTHH	1D89h RA1PPS	1E0Ch	1E8Ch	1F0Ch UMTOAL	1F8Ch
	1C8Eh NVMADLTL	100Eh ADUTHL	1D8Ah RA2PPS			1F0Dh UMTOAH	
	1C8Fh NVMADATH	100Fh ADUTHH	1D8Bh —			1F0Eh —	
	1C90h NVMCON1	1010h ADERRL	1D8Ch RA4PPS			1F0Fh —	
	1C91h NVMCON2	1011h ADERRH	1D8Dh —				
	1C92h SCANLADRL	1012h ADSTPTL	1D8Eh —				
	1C93h SCANLADRH	1013h ADSTPTH	1D8Fh —				
	1C94h —	1014h ADFLTRL	1D90h —				
	1C95h SCANHADRL	1015h ADFLTRH	1D91h —				
	1C96h SCANHADRH	1016h ADACCL	1D92h —				
	1C97h —	1017h ADACCH	1D93h —				
	1C98h SCANCON	1018h ADACCU	1D94h —				
	1C99h SCANDTI	1019h ADCNT	1D95h —				
	1C9Ah CRCDATAL	101Ah ADRPT	1D96h —				
	1C9Bh CRCDATAH	101Bh ADPREVL	1D97h —				
	1C9Ch CRCDATAU	101Ch ADPREVH	1D98h RB4PPS ⁽¹⁾				
	1C9Dh CRCDATAT	101Dh ADRESL	1D99h RB5PPS ⁽¹⁾				
	1C9Eh CRCCOUTL	101Eh ADRESH	1D9Ah RB6PPS ⁽¹⁾				
	1C9Fh CRCCOUTH	101Fh ADPCH	1D9Bh RB7PPS ⁽¹⁾				
	1CA0h CRCCOUTU	1020h ADNCH	1D9Ch RC0PPS				
	1CA1h CRCCOUTT	1021h ADACQL	1D9Dh RC1PPS				
	1CA2h CRCCON0	1022h ADACQH	1D9Eh RC2PPS				
	1CA3h CRCCON1	1023h ADCAP	1D9Fh RC3PPS				
	1CA4h CRCCON2	1024h ADPREL	1DA0h RC4PPS				
	1CA5h	1025h ADPREH	1DA1h RC5PPS				
		1026h ADCON0	1DA2h RC6PPS ⁽¹⁾				
		1027h ADCON1	1DA3h RC7PPS ⁽¹⁾				
		1028h ADCON2	1DA4h				
		1029h ADCON3					
		102Ah ADSTAT					
		102Bh ADREF					
		102Ch ADACT					
		102Dh ADCLK					
		102Eh ADCG1A					
		102Fh ADCG1B ⁽¹⁾					
		1030h ADCG1C					
		1031h					
		Unimplemented Read as '0'					
1C6Fh	1CEFh	106Fh	1DEFh	1E6Fh	1EEFh	1F6Fh	1FE3h
1C70h	1CF0h	1070h	1DF0h	1E70h	1EF0h	1F70h	1FE4h
1C7Fh	1CF7h	107Fh	1DF7h	1E7Fh	1EF7h	1F7Fh	1FE5h
							1FE6h
							1FE7h
							1FE8h
							1FE9h
							1FEAh
							1FEBh
							1FECb
							1FEDb
							1FEFb
							1FF0b
							1FF1b
							1FF2b
							1FF3b
							1FF4b
							1FF5b
							1FF6b
							1FF7b
							1FF8b
							1FF9b
							1FFAh
							1FFBh
							1FFCh
							1FFDh
							1FFEh
							1FFFh
							Unimplemented Read as '0'
							STATUS_SHAD
							WREG_SHAD
							BSR_SHAD
							PCLATH_SHAD
							FSROL_SHAD
							FSROH_SHAD
							FSR1L_SHAD
							FSR1H_SHAD
							—
							STKPTR
							TOSH
							Common RAM (Accesses 70h-7Fh)

Note: 1. Available on 20-pin devices only.
Legend: Unimplemented data memory locations, read as '0'.

Figure 9-11. Memory Map Bank 60

BANK 60	
1E00h	Core Registers
1E0Bh	
1E0Ch	PPSLOCK
1E0Dh	INTPPS
1E0Eh	TOCKIPPS
1E0Fh	T1CKIPPS
1E10h	T1GPPS
1E11h	T3CKIPPS
1E12h	T3GPPS
1E13h	Unimplemented Read as '0'
1E18h	
1E19h	T2INPPS
1E1Ah	T4INPPS
1E1Bh	Unimplemented Read as '0'
1E1Dh	
1E1Eh	CCP1PPS
1E1Fh	CCP2PPS
1E20h	Unimplemented Read as '0'
1E23h	
1E24h	PWMIN0PPS
1E25h	PWMIN1PPS
1E26h	PWM1ERSPPS
1E27h	PWM2ERSPPS
1E28h	Unimplemented Read as '0'
1E38h	
1E39h	CWG1PPS
1E3Ah	Unimplemented Read as '0'
1E3Ch	
1E3Dh	CLCIN0PPS
1E3Eh	CLCIN1PPS
1E3Fh	CLCIN2PPS
1E40h	CLCIN3PPS
1E41h	DT1PPS
1E42h	RX1PPS
1E43h	DT2PPS
1E44h	RX2PPS
1E45h	—
1E46h	—
1E47h	SSP1CLKPPS
1E48h	SSP1DATPPS
1E49h	SSP1SSPPS
1E4Ah	SSP2CLKPPS
1E4Bh	SSP2DATPPS
1E4Ch	SSP2SSPPS
1E4Dh	Unimplemented Read as '0'
1E4Fh	
1E50h	ADACTPPS
1E51h	Unimplemented Read as '0'
1E6Fh	
1E70h	Common RAM (Accesses 70h-7Fh)
1E7Fh	

Legend:

Unimplemented data memory locations, read as '0'.

Figure 9-12. Memory Map Bank 61

BANK 61			
1E80h	Core Registers	1EA0h	ANSEL
1E8Bh		1EA1h	WPUC
1E8Ch	ANSELA	1EA2h	ODCONC
1E8Dh	WPUA	1EA3h	SLRCONC
1E8Eh	ODCONA	1EA4h	INLVLC
1E8Fh	SLRCONA	1EA5h	IOCCP
1E90h	INLVLA	1EA6h	IOCCN
1E91h	IOCAP	1EA7h	IOCCF
1E92h	IOCAN	1EA8h	Unimplemented Read as '0'
1E93h	IOCAF	1EE4h	
1E94h	—	1EE5h	RB4I2C ⁽²⁾
1E95h	—	1EE6h	RB5I2C ⁽²⁾
1E96h	ANSELB ⁽¹⁾	1EE7h	RB6I2C ⁽²⁾
1E97h	WPUB ⁽¹⁾	1EE8h	RB7I2C ⁽²⁾
1E98h	ODCONB ⁽¹⁾	1EE9h	RC0I2C ⁽³⁾
1E99h	SLRCONB ⁽¹⁾	1EEAh	RC1I2C ⁽³⁾
1E9Ah	INLVLB ⁽¹⁾	1EEBh	—
1E9Bh	IOCBP ⁽¹⁾	1EECh	RC4I2C ⁽³⁾
1E9Ch	IOCBN ⁽¹⁾	1EEDh	RC5I2C ⁽³⁾
1E9Dh	IOCBF ⁽¹⁾	1EEEh	—
1E9Eh	—	1EEFh	—
1E9Fh	—	1EF0h	Common RAM (Accesses 70h-7Fh)
		1EFFh	

- Notes:**
1. Available on 20-pin devices only.
 2. Available on PIC16F18146 only.
 3. Available on PIC16F18126 only.

Legend:

■ Unimplemented data memory locations, read as '0'.

9.3 STATUS Register

The [STATUS](#) register contains:

- the arithmetic status of the ALU
- the Reset status

The STATUS register can be the destination for any instruction, like any other register. If the STATUS register is the destination for an instruction that affects the [Z](#), [DC](#) or [C](#) bits, then writes to these three bits are disabled. These bits are set or cleared according to the device logic. Furthermore, the [TO](#) and [PD](#) bits are not writable. Therefore, the result of an instruction with the STATUS register as destination may be different than intended.

For example, `CLRF STATUS` will clear bits [4:3] and [1:0] and set the **Z** bit. This leaves the STATUS register as '000u u1uu' (where u = unchanged).

It is recommended, therefore, that only `BCF`, `BSF`, `SWAPF` and `MOVWF` instructions are used to alter the STATUS register, because these instructions do not affect any Status bits. For other instructions not affecting any Status bits, refer to the **"Instruction Set Summary"** chapter.



Important: The C and DC bits operate as Borrow and Digit Borrow out bits, respectively, in subtraction.

9.4 PCL and PCLATH

The Program Counter (PC) is 15 bits wide. The low byte comes from the **PCL** register, which is a readable and writable register. The high byte (PC[14:8]) is not directly readable or writable and comes from **PCLATH**. On any Reset, the PC is cleared. [Loading of PC in Different Situations](#) shows the five situations for the loading of the PC.

Figure 9-13. Loading of PC in Different Situations

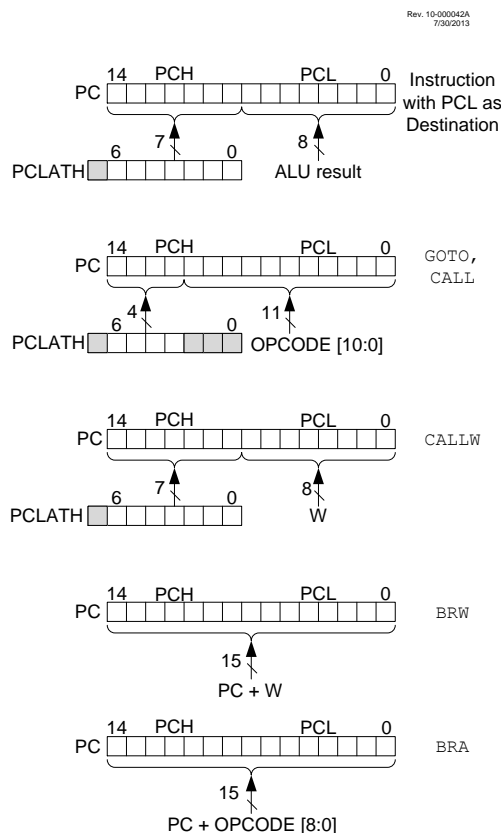

9.4.1 Modifying PCL

Executing any instruction with the **PCL** register as the destination simultaneously causes the Program Counter PC[14:8] bits (PCH) to be replaced by the contents of the **PCLATH** register. This allows the entire contents of the Program Counter to be changed by writing the desired upper seven bits to the PCLATH register. When the lower eight bits are written to the PCL register, all 15 bits of the Program Counter will change to the values contained in the PCLATH register and those being written to the PCL register.

9.4.2 Computed GOTO

A computed GOTO is accomplished by adding an offset to the Program Counter (ADDWF PCL). When performing a table read using a computed GOTO method, care has to be exercised if the table location crosses a PCL memory boundary (each 256-byte block). Refer to the following Microchip application note, available at the corporate website (www.microchip.com):

- AN556, "Implementing a Table Read"

9.4.3 Computed Function Calls

A computed function CALL allows programs to maintain tables of functions and provide another way to execute state machines or Look-up Tables. When performing a table read using a computed function CALL, care has to be exercised if the table location crosses a PCL memory boundary (each 256-byte block).

If using the CALL instruction, the PCH[2:0] and PCL registers are loaded with the operand of the CALL instruction. PCH[6:3] is loaded with PCLATH[6:3].

The CALLW instruction enables computed calls by combining PCLATH and W to form the destination address. A computed CALLW is accomplished by loading the W register with the desired address and executing CALLW. The PCL register is loaded with the value of W and PCH is loaded with PCLATH.

9.4.4 Branching

The branching instructions add an offset to the PC. This allows relocatable code and code that crosses page boundaries. There are two forms of branching, BRW and BRA. The PC will have incremented to fetch the next instruction in both cases. When using either branching instruction, a PCL memory boundary may be crossed.

If using BRW, load the W register with the desired unsigned address and execute BRW. The entire PC will be loaded with the address $PC + 1 + W$.

If using BRA, the entire PC will be loaded with $PC + 1 +$ the signed value of the operand of the BRA instruction.

9.5 Stack

All devices have a 16-level by 15-bit wide hardware stack. The stack space is not part of either program or data space. The PC is PUSHed onto the stack when the CALL or CALLW instructions are executed or an interrupt causes a branch. The stack is POPed in the event of a RETURN, RETLW or a RETFIE instruction execution. PCLATH is not affected by a PUSH or POP operation.

The stack operates as a circular buffer if the STVREN Configuration bit is programmed to '0'. This means that after the stack has been PUSHed sixteen times, the seventeenth PUSH overwrites the value that was stored from the first PUSH. The eighteenth PUSH overwrites the second PUSH, and so on. The STKOVF and STKUNF flag bits will be set on an Overflow/Underflow, regardless of whether the Reset is enabled.

If the STVREN bit is programmed to '1', the device will be reset if the stack is PUSHed beyond the sixteenth level or POPed beyond the first level, setting the appropriate bits (STKOVF or STKUNF, respectively).



Important: There are no instructions/mnemonics called PUSH or POP. These are actions that occur from the execution of the CALL, CALLW, RETURN, RETLW and RETFIE instructions or the vectoring to an interrupt address.

9.5.1 Accessing the Stack

The stack is accessible through the TOSH, TOSL and STKPTR registers. STKPTR is the current value of the Stack Pointer. The TOSH:TOSL register pair points to the TOP of the stack. Both registers are read/writable. TOS is split into TOSH and TOSL due to the 15-bit size of the PC. To access the stack, adjust the value of STKPTR, which will position TOSH:TOSL, then read/write to TOSH:TOSL. STKPTR also allows the detection of Overflow and Underflow condition.



Important: Care must be taken when modifying STKPTR while interrupts are enabled.

During normal program operation, `CALL`, `CALLW` and interrupts will increment STKPTR, while `RETLW`, `RETURN` and `RETFIE` will decrement STKPTR. STKPTR can be monitored to obtain the value of stack memory left at any given time. STKPTR always points at the currently used place on the stack. Therefore, a `CALL` or `CALLW` will increment STKPTR and then write the PC, and a return will unload the PC value from the stack and then decrement STKPTR.

Reference the following figures for examples of accessing the stack.

Figure 9-14. Accessing the Stack Example 1

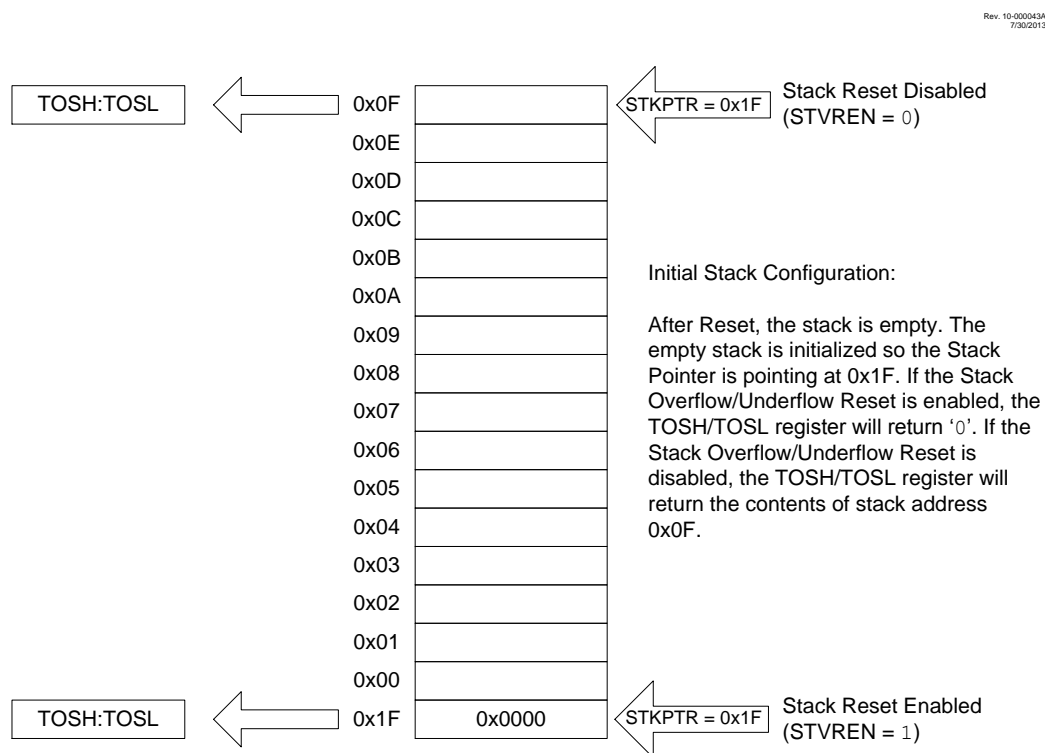

Figure 9-15. Accessing the Stack Example 2

Rev. 10-000043B
7/30/2013

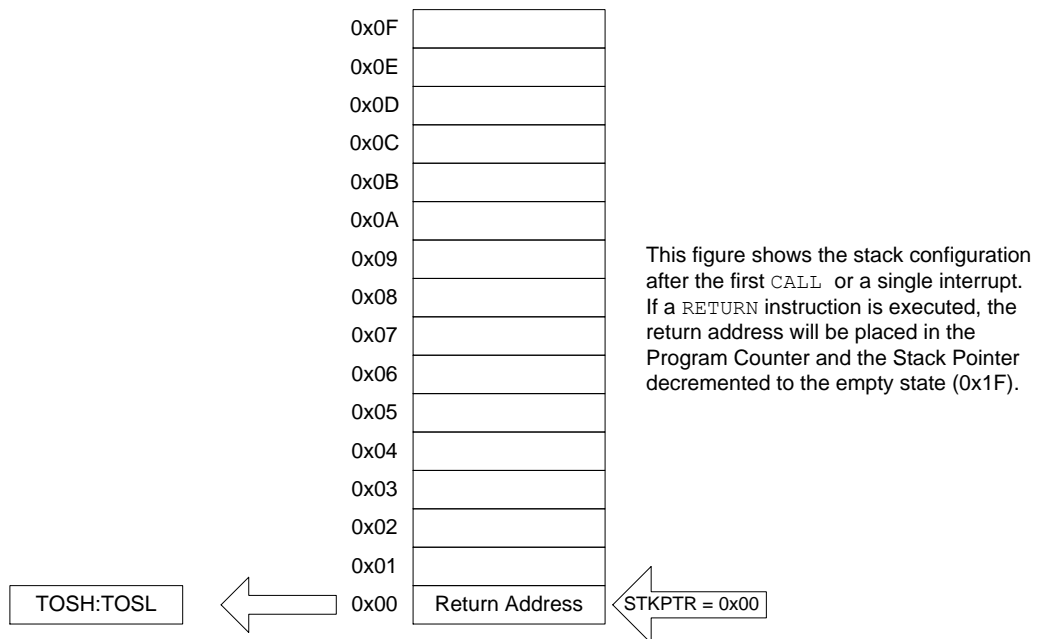

Figure 9-16. Accessing the Stack Example 3

Rev. 10-000043C
7/30/2013

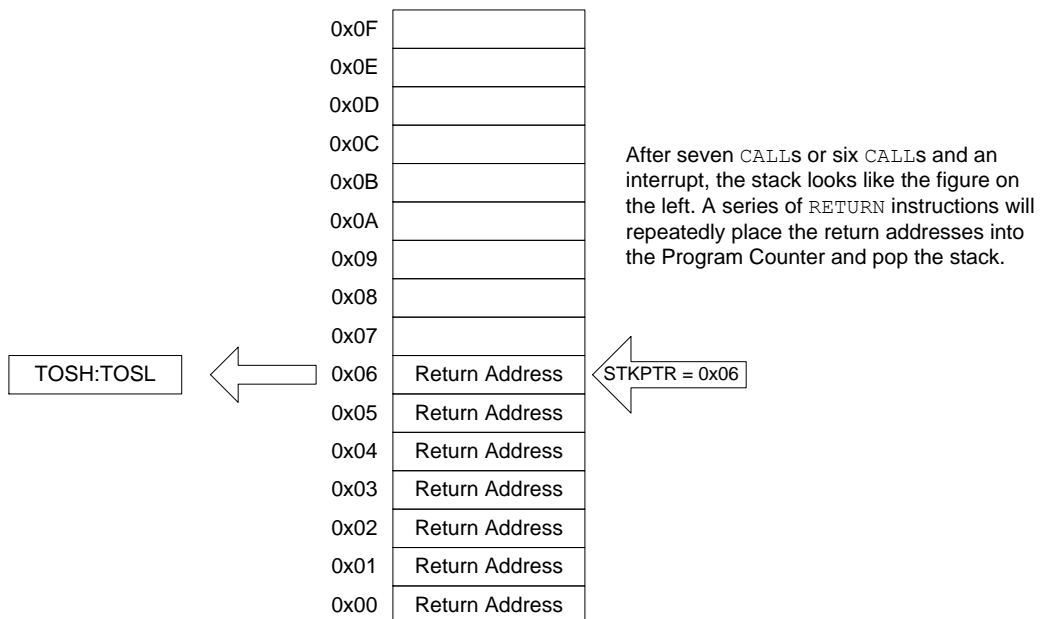
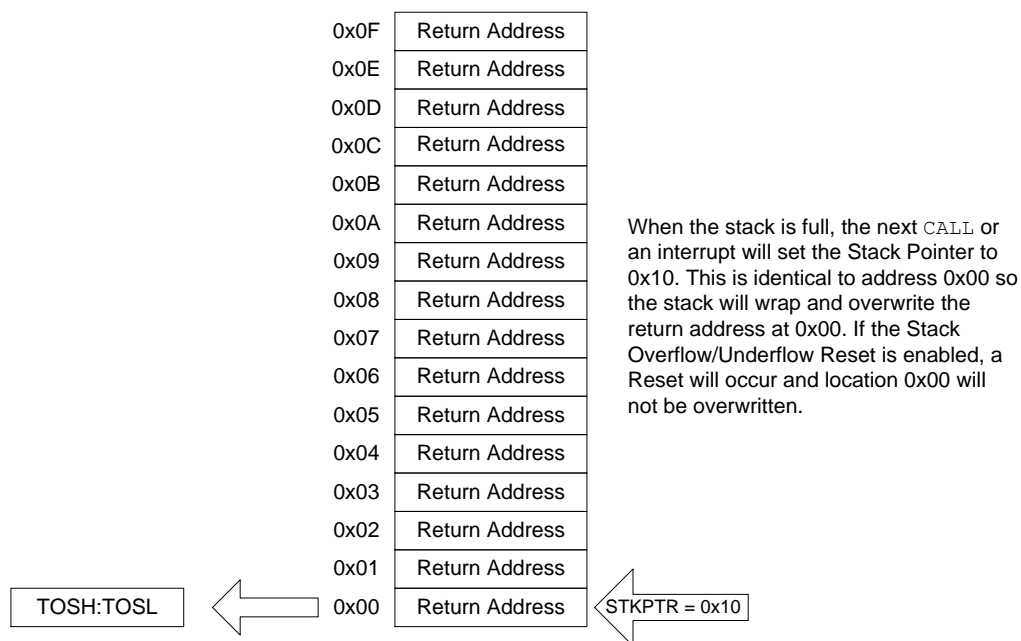

Figure 9-17. Accessing the Stack Example 4

Rev. 10-000043D
7/9/2013



9.5.2 Overflow/Underflow Reset

If the STVREN bit is programmed to '1', the device will be reset if the stack is PUSHed beyond the sixteenth level or POPed beyond the first level, setting the appropriate bits (STKOVF or STKUNF, respectively).

9.6 Indirect Addressing

The `INDFn` registers are not physical registers. Any instruction that accesses an `INDFn` register actually accesses the register at the address specified by the File Select Registers (`FSR`). If the `FSRn` address specifies one of the two `INDFn` registers, the read will return '0' and the write will not occur (though Status bits may be affected). The `FSRn` register value is created by the pair `FSRnH` and `FSRnL`.

The `FSR` registers form a 16-bit address that allows an addressing space with 65536 locations. These locations are divided into three memory regions:

- Traditional/Banked Data Memory
- Linear Data Memory
- Program Flash Memory

Figure 9-18. Indirect Addressing

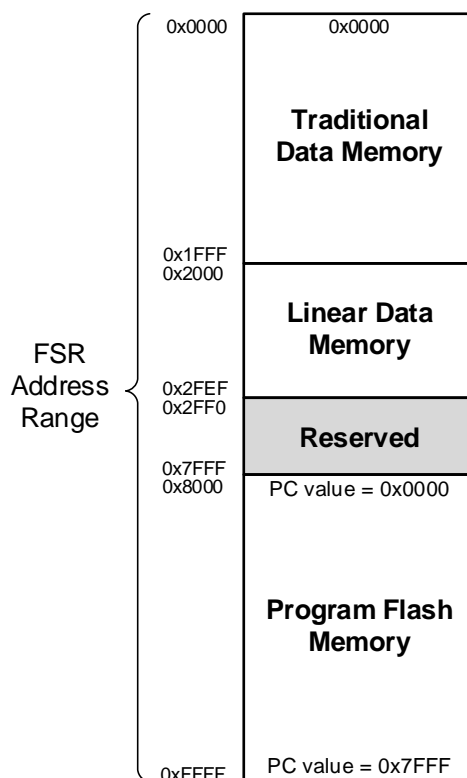

9.6.1 Traditional/Banked Data Memory

The traditional or banked data memory is a region from FSR address 0x0000 to FSR address 0x1FFF. The addresses correspond to the absolute addresses of all SFR, GPR and common registers.

Figure 9-19. Traditional/Banked Data Memory Map

Rev. 10-000056B
12/14/2016

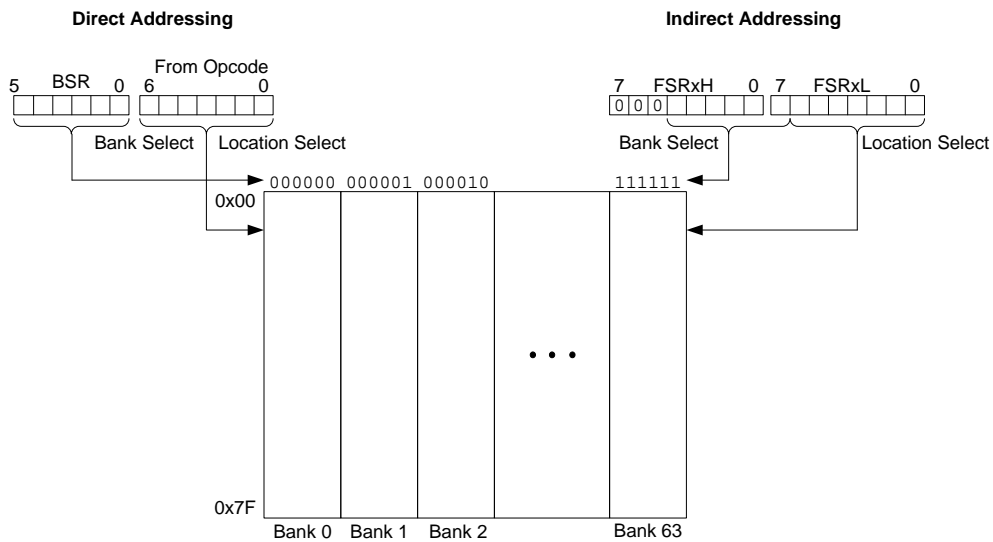

9.6.2 Linear Data Memory

The linear data memory is the region from FSR address 0x2000 to FSR address 0x2FEF. This region is a virtual region that points back to the 80-byte blocks of GPR memory in all the banks. Refer to Figure 9-20 for the Linear Data Memory Map.

Figure 9-20. Linear Data Memory Map

Rev. 10-000057B
8/24/2016

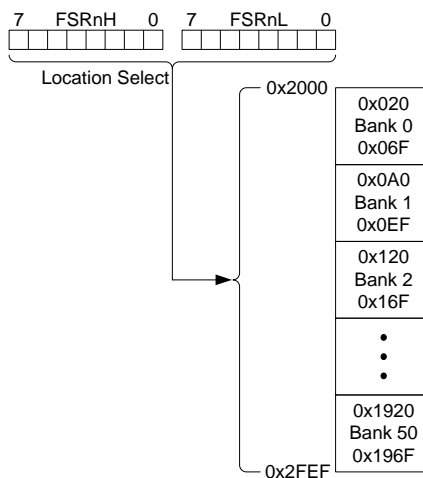

Important: The address range 0x2000 to 0x2FEF represents the complete addressable Linear Data Memory for PIC® devices (up to Bank 50). The actual implemented Linear Data Memory will differ from one device to the other in a family.

Unimplemented memory reads as 0x00. Use of the linear data memory region allows buffers to be larger than 80 bytes because incrementing the FSR beyond one bank will go directly to the GPR memory of the next bank.

The 16 bytes of common memory are not included in the linear data memory region.

9.6.3 Program Flash Memory

To make constant data access easier, the entire Program Flash Memory is mapped to the upper half of the FSR address space. When the MSB of FSRnH is set, the lower 15 bits are the address in program memory which will be accessed through INDF. Only the lower eight bits of each memory location are accessible via INDF. Writing to the Program Flash Memory cannot be accomplished via the FSR/INDF interface. All instructions that access Program Flash Memory via the FSR/INDF interface will require one additional instruction cycle to complete.

Figure 9-21. Program Flash Memory Map

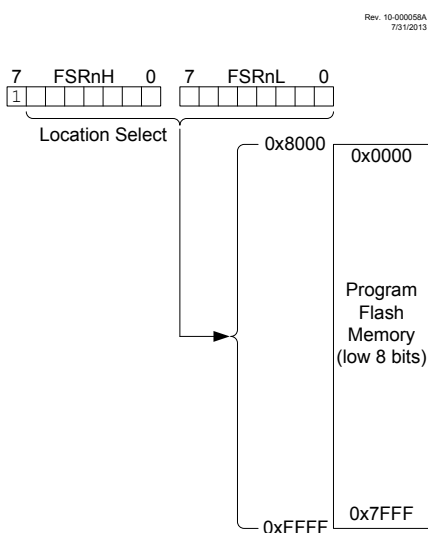

9.6.4 Data EEPROM Memory

The EEPROM memory can be read or written through the NVMCON register interface. However, to make access to the EEPROM easier, read-only access to the EEPROM contents are also available through indirect addressing via an FSR. When the MSP of the FSR (ex: FSRxH) is set to 0x70, the lower 8-bit address value (in FSRxL) determines the EEPROM location that may be read via the INDF register). In other words, the EEPROM address range 0x00-0xFF is mapped into the FSR address space between 0x7000 and 0x70FF. Writing to the EEPROM cannot be accomplished via the FSR/INDF interface. Reads from the EEPROM through the FSR/INDF interface will require one additional instruction cycle to complete.

9.7 Register Definitions: Memory Organization

9.7.1 INDF0

Name: INDF0
Offset: 0x0000

Indirect Data Register. This is a virtual register. The GPR/SFR register addressed by the FSR0 register is the target for all operations involving the INDF0 register.

Bit	7	6	5	4	3	2	1	0
	INDF0[7:0]							
Access	R/W	R/W	R/W	R/W	R/W	R/W	R/W	R/W
Reset	0	0	0	0	0	0	0	0

Bits 7:0 – INDF0[7:0]

Indirect data pointed to by the FSR0 register

9.7.2 INDF1

Name: INDF1
Offset: 0x0001

Indirect Data Register. This is a virtual register. The GPR/SFR register addressed by the FSR1 register is the target for all operations involving the INDF1 register.

Bit	7	6	5	4	3	2	1	0
	INDF1[7:0]							
Access	R/W	R/W	R/W	R/W	R/W	R/W	R/W	R/W
Reset	0	0	0	0	0	0	0	0

Bits 7:0 – INDF1[7:0]

Indirect data pointed to by the FSR1 register

9.7.3 PCL

Name: PCL
Offset: 0x0002

Low byte of the Program Counter

Bit	7	6	5	4	3	2	1	0
	PCL[7:0]							
Access	R/W	R/W	R/W	R/W	R/W	R/W	R/W	R/W
Reset	0	0	0	0	0	0	0	0

Bits 7:0 – PCL[7:0]

Provides direct read and write access to the Program Counter

9.7.4 STATUS

Name: STATUS
Offset: 0x0003

Status Register

Bit	7	6	5	4	3	2	1	0
				$\overline{\text{TO}}$	$\overline{\text{PD}}$	$\overline{\text{Z}}$	$\overline{\text{DC}}$	$\overline{\text{C}}$
Access				R	R	R/W	R/W	R/W
Reset				1	1	0	0	0

Bit 4 – $\overline{\text{TO}}$ Time-Out

Reset States: POR/BOR = 1
All Other Resets = q

Value	Description
1	Set at power-up or by execution of CLRWDT or SLEEP instruction
0	A WDT time-out occurred

Bit 3 – $\overline{\text{PD}}$ Power-Down

Reset States: POR/BOR = 1
All Other Resets = q

Value	Description
1	Set at power-up or by execution of CLRWDT instruction
0	Cleared by execution of the SLEEP instruction

Bit 2 – $\overline{\text{Z}}$ Zero

Reset States: POR/BOR = 0
All Other Resets = u

Value	Description
1	The result of an arithmetic or logic operation is zero
0	The result of an arithmetic or logic operation is not zero

Bit 1 – $\overline{\text{DC}}$ Digit Carry/Borrow⁽¹⁾

ADDWF, ADDLW, SUBLW, SUBWF instructions
Reset States: POR/BOR = 0
All Other Resets = u

Value	Description
1	A carry-out from the 4th low-order bit of the result occurred
0	No carry-out from the 4th low-order bit of the result

Bit 0 – $\overline{\text{C}}$ Carry/Borrow⁽¹⁾

ADDWF, ADDLW, SUBLW, SUBWF instructions
Reset States: POR/BOR = 0
All Other Resets = u

Value	Description
1	A carry-out from the Most Significant bit of the result occurred
0	No carry-out from the Most Significant bit of the result occurred

Note:

- For $\overline{\text{Borrow}}$, the polarity is reversed. A subtraction is executed by adding the two's complement of the second operand. For Rotate ($\overline{\text{RRCF}}$, $\overline{\text{RLCF}}$) instructions, this bit is loaded with either the high or low-order bit of the Source register.

9.7.5 FSR0

Name: FSR0
Offset: 0x0004

Indirect Address Register

The FSR0 value is the address of the data to which the INDF0 register points.

Bit	15	14	13	12	11	10	9	8
	FSR0[15:8]							
Access	R/W	R/W	R/W	R/W	R/W	R/W	R/W	R/W
Reset	0	0	0	0	0	0	0	0
Bit	7	6	5	4	3	2	1	0
	FSR0[7:0]							
Access	R/W	R/W	R/W	R/W	R/W	R/W	R/W	R/W
Reset	0	0	0	0	0	0	0	0

Bits 15:0 – FSR0[15:0] Address of INDF0 data

Notes: The individual bytes in this multibyte register can be accessed with the following register names:

1. FSR0H: Accesses the high byte FSR0[15:8].
2. FSR0L: Accesses the low byte FSR0[7:0].

9.7.6 FSR1

Name: FSR1
Offset: 0x0006

Indirect Address Register

The FSR1 value is the address of the data to which the INDF1 register points.

Bit	15	14	13	12	11	10	9	8
	FSR1[15:8]							
Access	R/W	R/W	R/W	R/W	R/W	R/W	R/W	R/W
Reset	0	0	0	0	0	0	0	0
Bit	7	6	5	4	3	2	1	0
	FSR1[7:0]							
Access	R/W	R/W	R/W	R/W	R/W	R/W	R/W	R/W
Reset	0	0	0	0	0	0	0	0

Bits 15:0 – FSR1[15:0]

Address of INDF1 data

Notes: The individual bytes in this multibyte register can be accessed with the following register names:

1. FSR1H: Accesses the high byte FSR1[15:8].
2. FSR1L: Accesses the low byte FSR1[7:0].

9.7.7 BSR

Name: BSR
Offset: 0x0008

Bank Select Register

The BSR indicates the data memory bank by writing the bank number into the register. All data memory can be accessed directly via instructions or indirectly via FSRs.

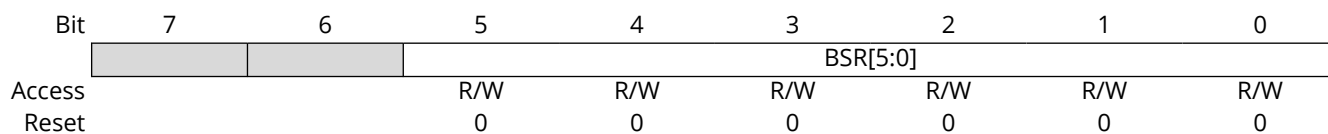

Bits 5:0 – BSR[5:0]

Six Most Significant bits of the data memory address

9.7.8 WREG

Name: WREG
Offset: 0x0009

Working Data Register

Bit	7	6	5	4	3	2	1	0
	WREG[7:0]							
Access	R/W	R/W	R/W	R/W	R/W	R/W	R/W	R/W
Reset	0	0	0	0	0	0	0	0

Bits 7:0 – WREG[7:0]

9.7.9 PCLATH

Name: PCLATH
Offset: 0x000A

Program Counter Latches

Write Buffer for the upper seven bits of the Program Counter

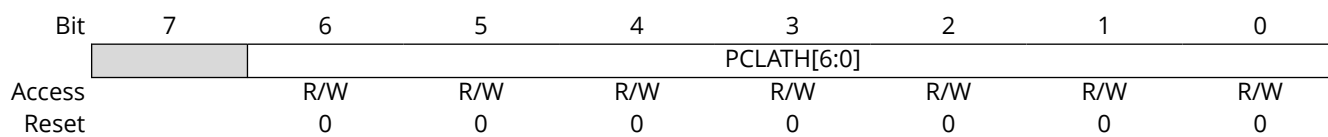

Bits 6:0 – PCLATH[6:0] High PC Latch Register
Holding register for Program Counter bits [6:0]

9.8 Register Summary - Memory Organization

Offset	Name	Bit Pos.	7	6	5	4	3	2	1	0
0x00	INDF0	7:0					INDF0[7:0]			
0x01	INDF1	7:0					INDF1[7:0]			
0x02	PCL	7:0					PCL[7:0]			
0x03	STATUS	7:0				TO	PD	Z	DC	C
0x04	FSR0	7:0					FSR0[7:0]			
		15:8					FSR0[15:8]			
0x06	FSR1	7:0					FSR1[7:0]			
		15:8					FSR1[15:8]			
0x08	BSR	7:0					BSR[5:0]			
0x09	WREG	7:0					WREG[7:0]			
0x0A	PCLATH	7:0					PCLATH[6:0]			

10. Resets

There are multiple ways to reset this device:

- Power-on Reset (POR)
- Brown-out Reset (BOR)
- $\overline{\text{MCLR}}$ Reset
- WDT Window Violation Reset
- WDT Reset
- RESET instruction
- Stack Overflow
- Stack Underflow
- Programming mode exit

To allow V_{DD} to stabilize, an optional Power-up Timer can be enabled to extend the Reset time after a BOR or POR event.

A simplified block diagram of the On-Chip Reset Circuit is shown in [Figure 10-1](#).

Figure 10-1. Simplified Block Diagram of On-Chip Reset Circuit

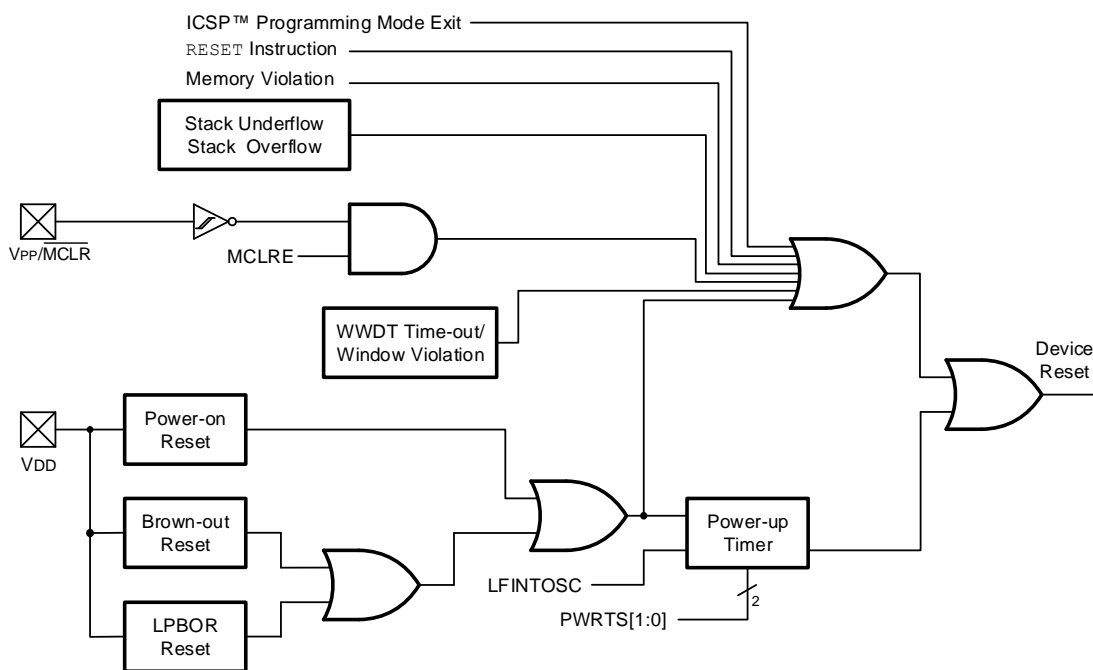

10.1 Power-on Reset (POR)

The POR circuit holds the device in Reset until V_{DD} has reached an acceptable level for minimum operation. Slow rising V_{DD} , fast operating speeds or analog performance may require greater than minimum V_{DD} . The PWRT, BOR or $\overline{\text{MCLR}}$ features can be used to extend the start-up period until all device operation conditions have been met.

10.1.1 Programming Mode Exit

Upon exit of Programming mode, the device will behave as if a POR had just occurred.

10.2 Brown-out Reset (BOR)

The BOR circuit holds the device in Reset when V_{DD} reaches a selectable minimum level. Between the POR and BOR, complete voltage range coverage for execution protection can be implemented.

The Brown-out Reset module has four operating modes controlled by the BOREN bits. The four operating modes are:

- BOR is always on
- BOR is off when in Sleep
- BOR is controlled by software
- BOR is always off

Refer to [Table 10-1](#) for more information.

The Brown-out Reset voltage level is selectable by configuring the BORV bits.

A V_{DD} noise rejection filter prevents the BOR from triggering on small events. If V_{DD} falls below V_{BOR} for a duration greater than parameter T_{BORDC} , the device will reset and the [BOR](#) bit will be cleared, indicating the Brown-out Reset condition occurred. See [Figure 10-2](#).

10.2.1 BOR Is Always On

When the BOREN bits are programmed to '11', the BOR is always on. The device start-up will be delayed until the BOR is ready and V_{DD} is higher than the BOR threshold.

BOR protection is active during Sleep. The BOR does not delay wake-up from Sleep.

10.2.2 BOR Is Off in Sleep

When the BOREN bits are programmed to '10', the BOR is on, except in Sleep. BOR protection is not active during Sleep, but device wake-up will be delayed until the BOR can determine that V_{DD} is higher than the BOR threshold. The device wake-up will be delayed until the BOR is ready.

10.2.3 BOR Controlled by Software

When the BOREN bits of Configuration Words are programmed to '01', the BOR is controlled by the [SBOREN](#) bit. The device start-up is not delayed by the BOR Ready condition or the V_{DD} level.

BOR protection begins as soon as the BOR circuit is ready. The status of the BOR circuit is reflected in the [BORRDY](#) bit.

BOR protection is unchanged by Sleep.

Table 10-1. BOR Operating Modes

BOREN	SBOREN	Device Mode	BOR Mode	Instruction Execution upon:	
				Release of POR	Wake-up from Sleep
11 ⁽¹⁾	x	X	Active	Wait for release of BOR (BORRDY = 1)	Begins immediately
10	x	Awake	Active	Wait for release of BOR (BORRDY = 1)	N/A
		Sleep	Hibernate	N/A	Wait for release of BOR (BORRDY = 1)
01	1	X	Active	Wait for release of BOR (BORRDY = 1)	Begins immediately
	0	X	Hibernate		
00	x	X	Disabled	Begins immediately	

Note:

1. In this specific case, 'Release of POR' and 'Wake-up from Sleep', there is no delay in start-up. The BOR Ready flag (**BORRDY** = 1) will be set before the CPU is ready to execute instructions because the BOR circuit is forced on by the BOREN bits.

Figure 10-2. Brown-Out Situations

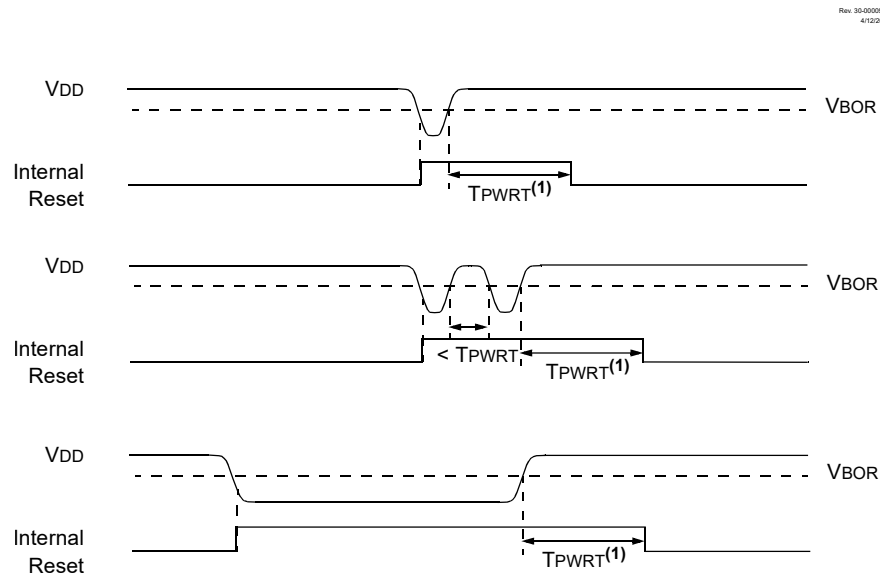

Note: T_{PWRT} delay when the PWRTS bits are enabled ($\overline{PWRTS} \neq 00$).

10.2.4 BOR Is Always Off

When the BOREN bits are programmed to '00', the BOR is always disabled. In the configuration, setting the **SBOREN** bit will have no affect on BOR operations.

10.3 MCLR Reset

The \overline{MCLR} is an optional external input that can reset the device. The \overline{MCLR} function is controlled by the MCLRE bit and the LVP bit (see [Table 10-2](#)). The **RMCLR** bit will be set to '0' if a \overline{MCLR} has occurred.

Table 10-2. \overline{MCLR} Configuration

MCLRE	LVP	\overline{MCLR}
x	1	Enabled
1	0	Enabled
0	0	Disabled

10.3.1 MCLR Enabled

When \overline{MCLR} is enabled and the pin is held low, the device is held in Reset. The \overline{MCLR} pin is connected to V_{DD} through an internal weak pull-up.

The device has a noise filter in the \overline{MCLR} Reset path. The filter will detect and ignore small pulses.



Important: An internal Reset event (**RESET** instruction, BOR, WDT, POR, STKOVF, STKUNF) does not drive the \overline{MCLR} pin low.

10.3.2 $\overline{\text{MCLR}}$ Disabled

When $\overline{\text{MCLR}}$ is disabled, the $\overline{\text{MCLR}}$ becomes input-only and pin functions such as internal weak pull-ups are under software control.

10.4 Windowed Watchdog Timer (WWDT) Reset

The Windowed Watchdog Timer generates a Reset if the firmware does not issue a `CLRWDT` instruction within the time-out period or window set. The $\overline{\text{TO}}$ and $\overline{\text{PD}}$ bits in the STATUS register and the `RWDT` bit are changed to indicate a WDT Reset. The `WDTWV` bit indicates if the WDT Reset has occurred due to a time-out or a window violation.

10.5 Watchdog Timer (WDT) Reset

The Watchdog Timer generates a Reset if the firmware does not issue a `CLRWDT` instruction within the time-out period. The `TO`, `PD` and `RWDT` bits are changed to indicate a WDT Reset caused by the timer overflowing.

10.6 RESET Instruction

A `RESET` instruction will cause a device Reset. The `RI` bit will be set to '0'. See Table 10-4 for default conditions after a `RESET` instruction has occurred.

10.7 Stack Overflow/Underflow Reset

The device can reset when the Stack Overflows or Underflows. The `STKOVF` or `STKUNF` bits indicate the Reset condition. These Resets are enabled by setting the `STVREN` bit.

10.8 Power-Up Timer (PWRT)

The Power-up Timer provides up to a 64 ms time-out period on POR or BOR. The device is held in Reset as long as `PWRT` is active. The `PWRT` delay allows additional time for the V_{DD} to rise to an acceptable level.

The Power-up Timer is controlled by the `PWRTS` bits. The Power-up Timer starts after the release of the POR and BOR. For additional information, refer to the following Microchip application note, available at the corporate website (www.microchip.com):

- AN607, "Power-up Trouble Shooting"

10.9 Start-Up Sequence

Upon the release of a POR or BOR, the following must occur before the device will begin executing:

1. Power-up Timer runs to completion (if enabled).
2. $\overline{\text{MCLR}}$ must be released (if enabled).

The Power-up Timer runs independently of $\overline{\text{MCLR}}$ Reset. If $\overline{\text{MCLR}}$ is kept low long enough, the Power-up Timer will expire. Upon bringing $\overline{\text{MCLR}}$ high, the device will begin execution after $10 F_{OSC}$ cycles (see Figure 10-3). This is useful for testing purposes or for synchronizing more than one device operating in parallel.

Figure 10-3. Reset Start-Up Sequence

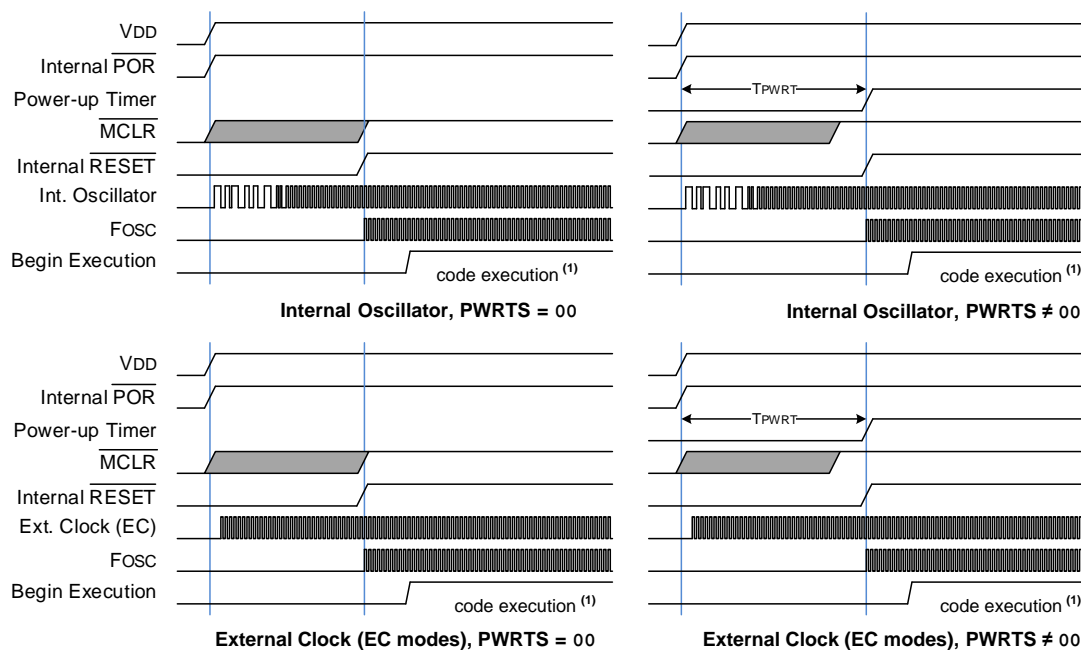
**Note:**

- Code execution begins 10 F_{OSC} cycles after the F_{OSC} clock is released.

10.10 Memory Execution Violation

A memory execution violation Reset occurs if executing an instruction being fetched from outside the valid execution area. The invalid execution areas are:

- Addresses outside implemented program memory. Refer to the **“Memory Organization”** chapter for details about available Flash size.
- Storage Area Flash (SAF) inside program memory, if enabled.

When a memory execution violation is generated, the device is reset and the \overline{MEMV} bit is cleared to signal the cause of the Reset. The \overline{MEMV} bit must be set in the user code after a memory execution violation Reset has occurred to detect further violation Resets.

10.11 Determining the Cause of a Reset

Upon any Reset, multiple bits in the STATUS, PCON0 and PCON1 registers are updated to indicate the cause of the Reset. The following tables show the Reset conditions of these registers.

Table 10-3. Reset Status Bits and Their Significance

STKOVF	STKUNF	RWDT	RMCLR	RI	POR	BOR	TO	PD	MEMV	Condition
0	0	1	1	1	0	x	1	1	1	Power-on Reset
0	0	1	1	1	0	x	0	x	u	Illegal, \overline{TO} is set on POR
0	0	1	1	1	0	x	x	0	u	Illegal, \overline{PD} is set on POR
0	0	u	1	1	u	0	1	1	u	Brown-out Reset
u	u	0	u	u	u	u	0	u	u	WDT Reset
u	u	u	u	u	u	u	0	0	u	WDT Wake-up from Sleep

.....continued

STKOVF	STKUNF	RWDT	RMCLR	RI	POR	BOR	TO	PD	MEMV	Condition
u	u	u	u	u	u	u	1	0	u	Interrupt Wake-up from Sleep
u	u	u	0	u	u	u	u	u	1	MCLR Reset during normal operation
u	u	u	0	u	u	u	1	0	u	MCLR Reset during Sleep
u	u	u	u	0	u	u	u	u	u	RESET Instruction Executed
1	u	u	u	u	u	u	u	u	u	Stack Overflow Reset (STVREN = 1)
u	1	u	u	u	u	u	u	u	u	Stack Underflow Reset (STVREN = 1)
u	u	u	u	u	u	u	u	u	0	Memory Violation Reset

Table 10-4. Reset Conditions for Special Registers

Condition	Program Counter	STATUS Register	PCON0 Register	PCON1 Register
Power-on Reset	0	---1 1000	0011 110x	---- --1-
Brown-out Reset	0	---1 1000	0011 11u0	---- --u-
MCLR Reset during normal operation	0	-uuu uuuu	uuuu 0uuu	---- --1-
MCLR Reset during Sleep	0	---1 0uuu	uuuu 0uuu	---- --u-
WDT Time-out Reset	0	---0 uuuu	uuu0 uuuu	---- --u-
WDT Wake-up from Sleep	PC + 1	---0 0uuu	uuuu uuuu	---- --u-
Interrupt Wake-up from Sleep	PC + 1 ⁽¹⁾	---1 0uuu	uuuu uuuu	---- --u-
RESET Instruction Executed	0	---u uuuu	uuuu u0uu	---- --u-
Stack Overflow Reset (STVREN = 1)	0	---u uuuu	1uuu uuuu	---- --u-
Stack Underflow Reset (STVREN = 1)	0	---u uuuu	u1uu uuuu	---- --u-
Memory Violation Reset	0	-uuu uuuu	uuuu uuuu	---- --0-

Legend: u = unchanged, x = unknown, — = unimplemented bit, reads as '0'.

Note:

1. When the wake-up is due to an interrupt and Global Interrupt Enable (GIE) bit is set, the return address is pushed on the stack and PC is loaded with the interrupt vector (0004h) after execution of PC + 1.

10.12 Power Control (PCONx) Register

The Power Control (PCONx) registers contain flag bits to differentiate between a:

- Brown-out Reset (\overline{BOR})
- Power-on Reset (\overline{POR})
- RESET Instruction Reset (\overline{RI})
- MCLR Reset (\overline{RMCLR})
- Watchdog Timer Window Violation Reset (\overline{WDTWV})
- Watchdog Timer Reset (\overline{RWDT})
- Stack Underflow Reset (STKUNF)
- Stack Overflow Reset (STKOVF)
- Memory Violation Reset (\overline{MEMV})

Hardware will change the corresponding register bit during the Reset process; if the Reset was not caused by the condition, the bit remains unchanged.

Software may reset the bit to the Inactive state after restart (hardware will not reset the bit).

Software may also set any PCONx bit to the Active state, so that user code may be tested, but no Reset action will be generated.

10.13 Register Definitions: Power Control

10.13.1 BORCON

Name: BORCON

Offset: 0x0191

Brown-out Reset Control Register

Bit	7	6	5	4	3	2	1	0
	SBOREN							BORRDY
Access	R/W							R
Reset	1							q

Bit 7 – SBOREN Software Brown-Out Reset Enable

Reset States: POR/BOR = 1

All Other Resets = u

Value	Condition	Description
–	If BOREN ≠ 01	SBOREN is read/write, but has no effect on the BOR
1	If BOREN = 01	BOR Enabled
0	If BOREN = 01	BOR Disabled

Bit 0 – BORRDY Brown-Out Reset Circuit Ready Status

Reset States: POR/BOR = q

All Other Resets = u

Value	Description
1	The Brown-out Reset circuit is active and armed
0	The Brown-out Reset circuit is disabled or is warming up

10.13.2 PCON0

Name: PCON0

Offset: 0x0192

Power Control Register 0

Bit	7	6	5	4	3	2	1	0
	STKOVF	STKUNF	WDTWV	RWDT	RMCLR	RI	POR	BOR
Access	R/W/HS	R/W/HS	R/W/HC	R/W/HC	R/W/HC	R/W/HC	R/W/HC	R/W/HC
Reset	0	0	1	1	1	1	0	q

Bit 7 – STKOVF Stack Overflow Flag

Reset States: POR/BOR = 0

All Other Resets = q

Value	Description
1	A Stack Overflow occurred (more CALLS than fit on the stack)
0	A Stack Overflow has not occurred or set to '0' by firmware

Bit 6 – STKUNF Stack Underflow Flag

Reset States: POR/BOR = 0

All Other Resets = q

Value	Description
1	A Stack Underflow occurred (more RETURNS than CALLS)
0	A Stack Underflow has not occurred or set to '0' by firmware

Bit 5 – WDTWV WDT Window Violation

Reset States: POR/BOR = 1

All Other Resets = q

Value	Description
1	A WDT Window Violation has not occurred or set to '1' by firmware
0	A CLRWD \overline{T} instruction was issued when the WDT reset window was closed (set to '0' by hardware when a WDT Window Violation reset occurs)

Bit 4 – RWDT WDT Reset Flag

Reset States: POR/BOR = 1

All Other Resets = q

Value	Description
1	A WDT Overflow/Time-out Reset has not occurred or set to '1' by firmware
0	A WDT Overflow/Time-out Reset has occurred (set to '0' in hardware when a WDT Reset occurs)

Bit 3 – RMCLR MCLR Reset Flag

Reset States: POR/BOR = 1

All Other Resets = q

Value	Description
1	A MCLR Reset has not occurred or set to '1' by firmware
0	A MCLR Reset has occurred (set to '0' in hardware when a MCLR Reset occurs)

Bit 2 – RI RESET Instruction Flag

Reset States: POR/BOR = 1

All Other Resets = q

Value	Description
1	A RESET instruction has not been executed or set to '1' by firmware
0	A RESET instruction has been executed (set to '0' in hardware upon executing a RESET instruction)

Bit 1 – $\overline{\text{POR}}$ Power-on Reset Status

Reset States: POR/BOR = 0

All Other Resets = u

Value	Description
1	No Power-on Reset occurred or set to '1' by firmware
0	A Power-on Reset occurred (set to '0' in hardware when a Power-on Reset occurs)

Bit 0 – $\overline{\text{BOR}}$ Brown-out Reset Status

Reset States: POR/BOR = q

All Other Resets = u

Value	Description
1	No Brown-out Reset occurred or set to '1' by firmware
0	A Brown-out Reset occurred (set to '0' in hardware when a Brown-out Reset occurs)

10.13.3 PCON1

Name: PCON1

Offset: 0x0193

Power Control Register 1

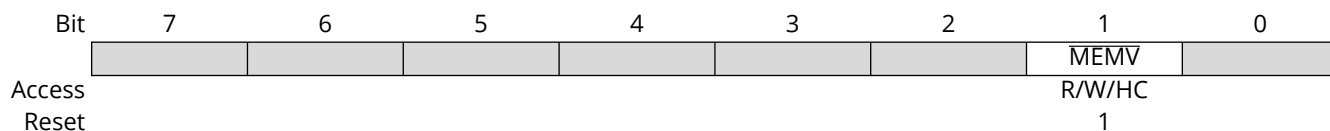

Bit 1 - **MEMV** Memory Violation Flag

Reset States: POR/BOR = 1

All Other Resets = u

Value	Description
1	No Memory Violation Reset occurred or set to '1' by firmware
0	A Memory Violation Reset occurred (set to '0' in hardware when a Memory Violation occurs)

10.14 Register Summary - Power Control

Offset	Name	Bit Pos.	7	6	5	4	3	2	1	0
0x00	Reserved									
...										
0x0190										
0x0191	BORCON	7:0	SBOREN							BORRDY
0x0192	PCON0	7:0	STKOVF	STKUNF	WDTWV	RWDT	RMCLR	RI	POR	BOR
0x0193	PCON1	7:0							MEMV	

11. OSC - Oscillator Module (With Fail-Safe Clock Monitor)

The oscillator module contains multiple clock sources and selection features that allow it to be used in a wide range of applications while maximizing performance and minimizing power consumption.

Clock sources can be supplied either internally or externally. External sources include:

- External clock oscillators
- Quartz crystal resonators
- Ceramic resonators
- Secondary Oscillator (SOSC)

Internal sources include:

- High-Frequency Internal Oscillator (HFINTOSC)
- Low-Frequency Internal Oscillator (LFINTOSC)
- Analog-to-Digital Converter RC Oscillator (ADCRC)

Special features of the oscillator module include:

- Oscillator Start-up Timer (OST): Ensures stability of quartz crystal or ceramic resonators.
- 4x Phase-Locked Loop (PLL): Frequency multiplier for external clock sources.
- HFINTOSC Frequency Adjustment: Provides the ability to adjust the HFINTOSC frequency.
- Clock switching: Allows the system clock to switch between internal or external sources via software during run time.
- Fail-Safe Clock Monitor (FSCM): Designed to detect a failure of the external clock source and automatically switch to an internal clock source.

The Reset Oscillator (RSTOSC) Configuration bits determine the type of oscillator that will be used when the device runs after a Reset, including when the device is first powered up (see the table below).

Table 11-1. RSTOSC Selection Table

RSTOSC	SFR Reset Values			Clock Source
	NOSC / COSC	NDIV / CDIV	OSCFRQ	
111	111	0000 (1:1)	010 (4 MHz)	EXTOSC per FEXTOSC
110	110	0010 (4:1)		HFINTOSC @ 1 MHz
101	101	0000 (1:1)		LFINTOSC
100	100	0000 (1:1)		SOSC
011			Reserved	
010	010	0000 (1:1)	010 (4 MHz)	EXTOSC + 4x PLL ⁽¹⁾
001			Reserved	
000	110	0000 (1:1)	101 (32 MHz)	HFINTOSC @ 32 MHz

Note:

1. EXTOSC must meet the PLL specifications (see the data sheet Electrical Specifications).

If an external clock source is selected by the RSTOSC bits, the External Oscillator Mode Select (FEXTOSC) Configuration bits must be used to select the External Clock mode. These modes include:

- ECL: External Clock Low-Power mode
- ECH: External Clock High-Power mode
- LP: 32 kHz Low-Gain Crystal mode

- XT: Medium-Gain Crystal or Ceramic Resonator mode
- HS: High-Gain Crystal or Ceramic Resonator mode

The ECH and ECL modes rely on an external logic-level signal as the device clock source. The LP, XT and HS modes rely on an external quartz crystal or ceramic resonator as the device clock source. Each mode is optimized for a specific frequency range. The internal oscillator block produces both low-frequency and high-frequency clock signals, designated LFINTOSC and HFINTOSC, respectively. Multiple system operating frequencies may be derived from these clock sources.

The figure below illustrates a block diagram of the oscillator module.

Figure 11-1. Clock Source Block Diagram

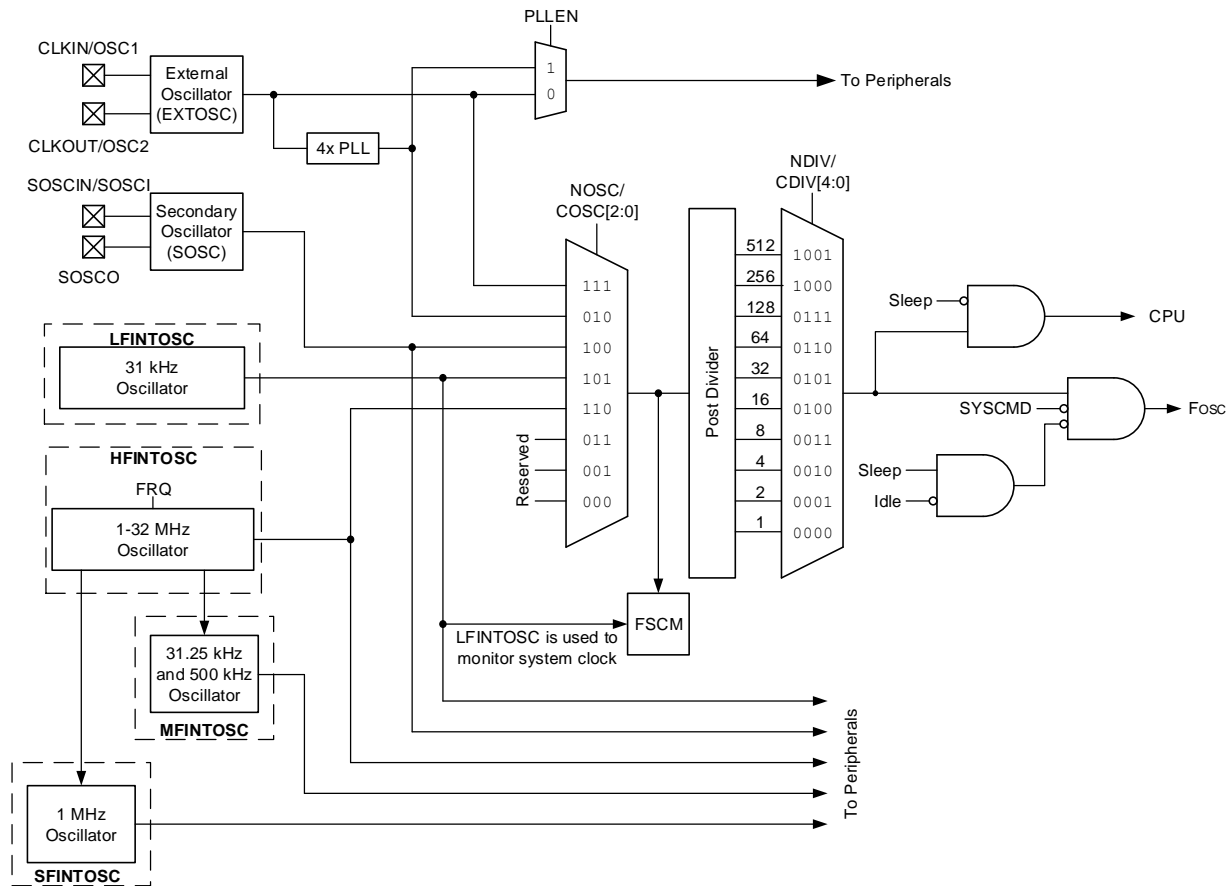

11.1 Clock Source Types

Clock sources can be classified as external or internal.

External clock sources rely on external circuitry for the clock source to function. Examples of external clock sources include:

- Digital oscillator modules
- Quartz crystal resonators
- Ceramic resonators

A 4x PLL is provided for use with external clock sources.

Internal clock sources are contained within the oscillator module. The internal oscillator block features two internal oscillators that are used to generate internal system clock sources. The High-Frequency Internal Oscillator (HFINTOSC) can produce a wide range of frequencies which are

determined via the HFINTOSC Frequency Selection (**OSCFRQ**) register. The Low-Frequency Internal Oscillator (LFINTOSC) generates a fixed nominal 31 kHz clock signal. The internal oscillator block also features an RC oscillator which is dedicated to the Analog-to-Digital Converter (ADC).

The oscillator module allows the system clock source or system clock frequency to be changed through clock switching. Clock source selections are made via the New Oscillator Source Request (**NOSC**) bits. Once the clock source has been selected, the clock source base frequency can be divided (post-scaled) via the New Divider Selection Request (**NDIV**) bits.

The instruction clock ($F_{OSC}/4$) can be routed to the OSC2/CLKOUT pin when the pin is not in use. The Clock Out Enable (**CLKOUTEN**) Configuration bit controls the functionality of the CLKOUT signal. When **CLKOUTEN** is clear ($\overline{\text{CLKOUTEN}} = 0$), the CLKOUT signal is routed to the OSC2/CLKOUT pin. When **CLKOUTEN** is set ($\overline{\text{CLKOUTEN}} = 1$), the OSC2/CLKOUT pin functions as an I/O pin.

11.1.1 External Clock Sources

An external clock source can be used as the device system clock by performing one of the following actions:

- Program the RSTOSC and FEXTOSC Configuration bits to select an external clock source that will be used as the default system clock upon a device Reset.
- Write the **NOSC** and **NDIV** bits to switch the system clock source during run time.

11.1.1.1 EC Mode

The External Clock (EC) mode allows an externally generated logic level signal to be the system clock source. When operating in EC mode, an external clock source is connected to the OSC1/CLKIN input pin. The OSC2/CLKOUT pin is available as a general purpose I/O pin or as the CLKOUT signal pin.

EC mode provides two Power mode selections:

- ECH: High-Power mode
- ECL: Low-Power mode

The Oscillator Start-up Timer (OST) is disabled when the EC mode is selected; therefore, there is no delay in operation after a Power-on Reset (POR) or wake-up from Sleep. Because the PIC[®] MCU design is fully static, stopping the external clock input will have the effect of halting the device while leaving all data intact. Upon restarting the external clock, the device will resume operation as if no time had elapsed.

The figure below shows the pin connections for EC mode.

Figure 11-2. External Clock (EC) Mode Operation

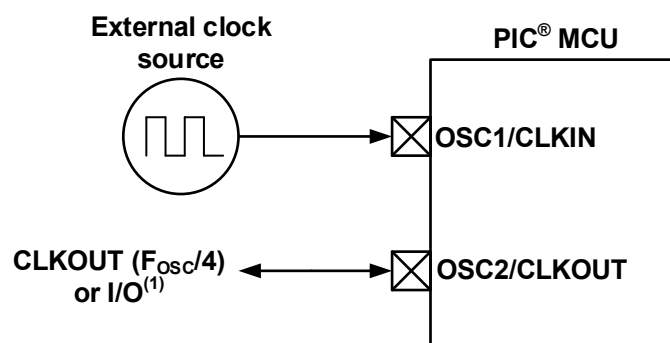

Note:

1. Output depends on the setting of the $\overline{\text{CLKOUTEN}}$ Configuration bit.

11.1.1.2 LP, XT, HS Modes

The LP, XT and HS modes support the use of quartz crystals or ceramic resonators connected to the OSC1 and OSC2 pins, as shown in the figures below. These three modes select a low-, medium-, or high-gain setting of the internal inverter-amplifier to support various resonator types and speeds.

The LP Oscillator mode selects the lowest gain setting of the internal inverter-amplifier and consumes the least amount of current. LP mode is designed to drive 32.768 kHz tuning-fork type crystals (watch crystals), but can operate up to 100 kHz.

The XT Oscillator mode selects the intermediate gain setting of the internal inverter-amplifier. Current consumption is at a medium level when compared to the other two modes. XT mode is best suited to drive crystal and ceramic resonators with a frequency range up to 4 MHz.

The HS Oscillator mode selects the highest gain setting of the internal inverter-amplifier and consumes the most current. This mode is best suited for crystal and ceramic resonators that require operating frequencies up to 20 MHz.

The figures below show typical circuits for quartz crystal and ceramic resonators.

Figure 11-3. Quartz Crystal Operation

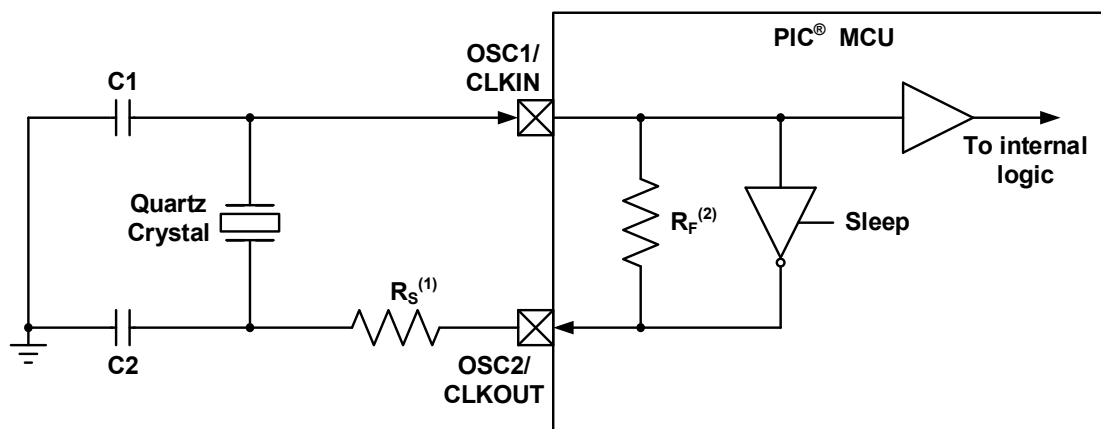
**Notes:**

1. A series resistor (R_S) may be required for quartz crystals with low drive level.
2. The value of R_F varies with the Oscillator mode selected (typically between 2 M Ω and 10 M Ω).

Figure 11-4. Ceramic Resonator Operation

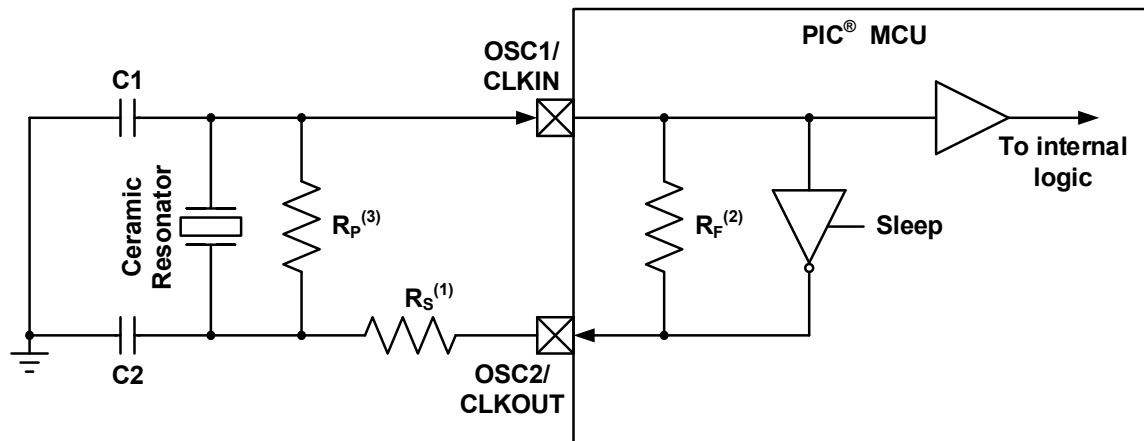
**Notes:**

1. A series resistor (R_S) may be required for ceramic resonators with low drive level.
2. The value of R_F varies with the Oscillator mode selected (typically between 2 M Ω and 10 M Ω).
3. An additional parallel feedback resistor (R_P) may be required for proper ceramic resonator operation.

11.1.1.3 Oscillator Start-Up Timer (OST)

The Oscillator Start-up Timer (OST) ensures that the oscillator circuit has started and is providing a stable system clock to the oscillator module. Quartz crystals or ceramic resonators do not start immediately and may take a few hundred cycles before the oscillator becomes stable. The oscillations must build up until sufficient amplitude is generated to properly toggle between logic states. The OST counts 1024 oscillation periods from the OSC1 input following a Power-on Reset (POR), Brown-out Reset (BOR), or wake-up from Sleep event to ensure that the oscillator has enough time to reach stable and accurate operation. Once the OST has completed its count, module hardware sets the External Oscillator Ready (**EXTOR**) bit, indicating that the oscillator is stable and ready to use.

11.1.1.4 4x PLL

The oscillator module contains a 4x Phase-Locked Loop (PLL) circuit that can be used with the external clock sources to provide a system clock source. The input frequency for the PLL must fall within a specified range. See the PLL Clock Timing Specifications found in the **"Electrical Specifications"** chapter for more information.

The PLL can be enabled for use through one of two methods:

1. Program the RSTOSC Configuration bits to select the 'EXTOSC with 4x PLL' option.
2. Write the **NOSC** bits to select the 'EXTOSC with 4x PLL' option.

11.1.1.5 Secondary Oscillator

The Secondary Oscillator (SOSC) is a separate external oscillator block that can be used as an alternate system clock source or as a Timer clock source. The SOSC is optimized for 32.768 kHz and can be used with either an external quartz crystal connected to the SOSC1 and SOSC0 pins or with an external clock source connected to the SOSC1 pin, as shown in the figures below.

Figure 11-5. SOSC 32.768 kHz Quartz Crystal Oscillator Operation

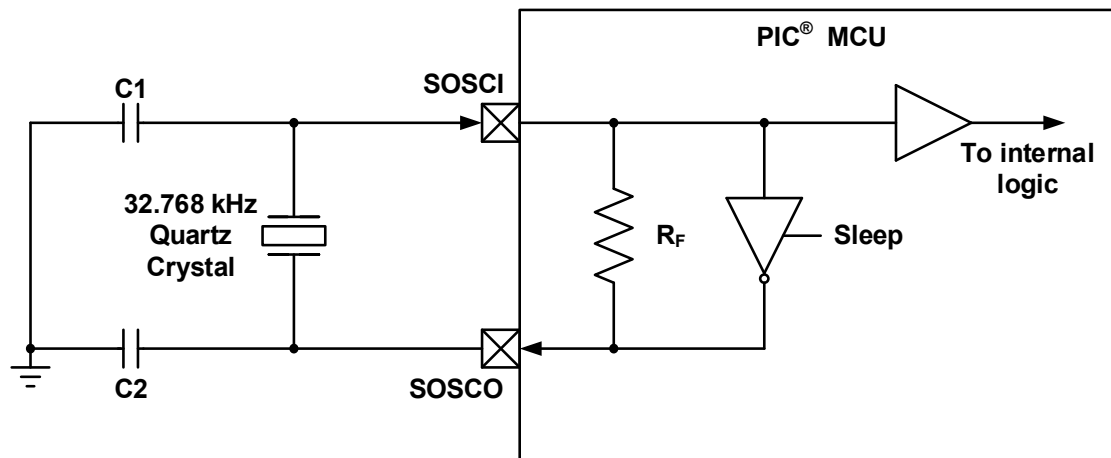
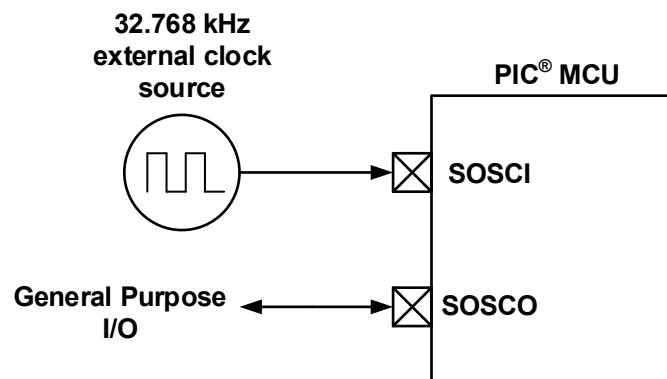

Figure 11-6. SOSC 32.768 kHz External Clock Operation



The SOSC can be enabled through one of two methods:

- Programming the RSTOSC Configuration bits to select the SOSC as the system clock
- Programming the **NOSC** bits to select the SOSC during run time

Two Power modes are available for the secondary oscillator and are selected using the Secondary Oscillator Power Mode Select (**SOSCPWR**) bit. When **SOSCPWR** is clear (**SOSCPWR** = 0), the oscillator operates in Low-Power mode, which is ideal for crystal oscillators with low drive strength. When **SOSCPWR** is set (**SOSCPWR** = 1), the oscillator operates in High-Power mode, which is ideal for crystal oscillators with high drive strength or high Equivalent Series Resistance (ESR).



Important: The SOSC module must be disabled before changing Power modes. Changes to the Power mode during operation may result in undefined oscillator behavior.

11.1.1.5.1 SOSC Start-Up Timing

The SOSC utilizes the Oscillator Start-up Timer (OST) to ensure that the 32.768 kHz crystal oscillator has started and is available for use. Since crystal oscillators do not start immediately and may take a few hundred cycles before achieving stable operation, the OST counts 1024 oscillation periods from the SOSCI input. Once the OST completes its count, module hardware sets the Secondary Oscillator Ready (SOR) bit, indicating that the SOSC is stable and ready to use.

11.1.2 Internal Clock Sources

The internal oscillator block contains two independent oscillators that can produce two internal system clock sources:

- High-Frequency Internal Oscillator (HFINTOSC)
- Low-Frequency Internal Oscillator (LFINTOSC)

Internal oscillator selection is performed one of two ways:

1. Program the RSTOSC Configuration bits to select one of the INTOSC sources which will be used upon a device Reset.
2. Write the New Oscillator Source Request (NOSC) bits to select an internal oscillator during run time.

In INTOSC mode, the OSC1/CLKIN and OSC2/CLKOUT pins are available for use as a general purpose I/Os, provided that no external oscillator is connected. The function of the OSC2/CLKOUT pin is determined by the CLKOUTEN Configuration bit. When CLKOUTEN is set (CLKOUTEN = 1), the pin functions as a general-purpose I/O. When CLKOUTEN is clear (CLKOUTEN = 0), the system instruction clock ($F_{OSC}/4$) is available as an output signal on the pin.

11.1.2.1 HFINTOSC

The High-Frequency Internal Oscillator (HFINTOSC) is a factory-calibrated, precision digitally-controlled internal clock source that produces a wide range of stable clock frequencies. The HFINTOSC can be enabled through one of the following methods:

- Program the RSTOSC Configuration bits to select the HFINTOSC upon device Reset or power-up
- Write to the New Oscillator Source Request (NOSC) bits to select the HFINTOSC during run time.

The HFINTOSC frequency is selected via the HFINTOSC Frequency Selection (FRQ) bits. Fine-tuning of the HFINTOSC is done via the HFINTOSC Frequency Tuning (TUN) bits. The HFINTOSC output frequency can be divided (post-scaled) via the New Divider Selection Request (NDIV) bits.

11.1.2.1.1 HFINTOSC Frequency Tuning

The HFINTOSC frequency can be fine-tuned via the HFINTOSC Tuning (OSCTUNE) register. The OSCTUNE register is used by Active Clock Tuning hardware or user software to provide small adjustments to the HFINTOSC nominal frequency.

The OSCTUNE register contains the HFINTOSC Frequency Tuning (TUN) bits. The TUN bits default to a 6-bit, two's complement value of $0x00$, which indicates that the oscillator is operating at the selected frequency. When a value between $0x01$ and $0x1F$ is written to the TUN bits, the HFINTOSC frequency is increased. When a value between $0x3F$ and $0x20$ is written to the TUN bits, the HFINTOSC frequency is decreased.

When the OSCTUNE register is modified, the oscillator will begin to shift to the new frequency. Code execution continues during this shift. There is no indication that the frequency shift occurred.



Important: OSCTUNE tuning does not affect the LFINTOSC frequency.

11.1.2.2 MFINTOSC

The Medium-Frequency Internal Oscillator (MFINTOSC) generates two constant clock outputs (500 kHz and 31.25 kHz). The MFINTOSC clock signals are created from the HFINTOSC using dynamic divider logic, which provides constant MFINTOSC clock rates regardless of selected HFINTOSC frequency.

The MFINTOSC cannot be used as the system clock, but can be used as a clock source for certain peripherals, such as a Timer.

11.1.2.3 SFINTOSC

The Specified-Frequency Internal Oscillator (SFINTOSC) generates a constant 1MHz clock output. The SFINTOSC clock signal is created from the HFINTOSC using dynamic divider logic, which provides constant SFINTOSC clock rates regardless of the selected HFINTOSC frequency.

The SFINTOSC cannot be used as the system clock, but provides a constant 1 MHz clock signal that is used for NVM Write and Erase operations. Additionally, SFINTOSC can be used as a clock source for certain peripherals.

11.1.2.4 LFINTOSC

The Low-Frequency Internal Oscillator (LFINTOSC) is a factory-calibrated 31 kHz internal clock source.

The LFINTOSC can be used as a system clock source and may be used by certain peripheral modules as a clock source. Additionally, the LFINTOSC provides a time base for the following:

- Power-up Timer (PWRT)
- Watchdog Timer (WDT)/Windowed Watchdog Timer (WWDT)
- Fail-Safe Clock Monitor (FSCM)

The LFINTOSC is enabled through one of the following methods:

- Program the RSTOSC Configuration bits to select LFINTOSC
- Write the [NOSC](#) bits to select LFINTOSC during run time

11.1.2.5 ADCRC

The Analog-to-Digital RC (ADCR) oscillator is dedicated to the ADC module. This oscillator is also referred to as the FRC clock. The ADCRC operates at a fixed frequency of approximately 600 kHz and is used as a conversion clock source. The ADCRC allows the ADC module to operate in Sleep mode, which can reduce system noise during the ADC conversion. The ADCRC is automatically enabled when it is selected as the clock source for the ADC module or when selected as the clock source of any peripheral that may use it. The ADCRC may also be manually enabled via the ADC Oscillator Enable ([ADOEN](#)) bit, thereby avoiding start-up delays when this source is used intermittently.

11.1.3 Oscillator Status and Manual Enable

The Oscillator Status ([OSCSTAT](#)) register displays the Ready status for each of the following oscillators:

- External oscillator
- HFINTOSC
- MFINTOSC
- LFINTOSC

- SOSC
- ADCRC
- SFINTOSC

The OSCSTAT register also displays the Ready status for the 4xPLL.

The HFINTOSC Oscillator Ready (**HFOR**), MFINTOSC Oscillator Ready (**MFOR**), LFINTOSC Oscillator Ready (**LFOR**), ADCRC Oscillator Ready (**ADOR**) and SFINTOSC Oscillator Ready (**SFOR**) Status bits indicate whether the respective oscillators are ready for use. These clock sources are available for use at any time, but may require a finite amount of time before they have reached the specified accuracy levels. When the oscillators are ready and have achieved the specified accuracy, module hardware sets the respective bits.

When a new value is loaded into the **OSCFRQ** register, the HFOR bit is cleared by hardware and will be set again once the HFINTOSC is ready. During pending OSCFRQ changes, the HFINTOSC will stall at either a high or a low state until the oscillator locks in the new frequency and resumes operation.

The External Oscillator Ready (**EXTOR**) and SOSC Oscillator Ready (**SOR**) Status bits indicate whether the respective external clock sources are ready for use. The external clock sources use the Oscillator Start-up Timer (OST) to determine when the oscillator is ready. Once the OST has expired, the external oscillator is ready for use, and module hardware sets the respective bits.

The Oscillator Enable (**OSCEN**) register can be used to manually enable the following oscillators:

- External oscillator
- HFINTOSC
- MFINTOSC
- LFINTOSC
- SOSC
- ADCRC



Important: OSCEN cannot be used to manually enable the 4xPLL.

11.2 Clock Switching

The system clock source can be switched between external and internal clock sources via software using the New Oscillator Source Request (**NOSC**) and New Divider Selection Request (**NDIV**) bits. The following sources can be selected:

- External Oscillator (EXTOSC)
- EXTOSC with 4x PLL
- High-Frequency Internal Oscillator (HFINTOSC)
- Low-Frequency Internal Oscillator (LFINTOSC)
- Secondary Oscillator (SOSC)

The Clock Switch Enable (CSWEN) Configuration bit can be used to enable or disable the clock switching capability. When CSWEN is set (CSWEN = 1), writes to NOSC and NDIV by user software will allow the system clock to switch between sources or frequencies. When CSWEN is clear (CSWEN = 0), writes to NOSC and NDIV are ignored, preventing the system clock from switching from one source to another.

11.2.1 NOSC and NDIV Bits

The New Oscillator Source Request (**NOSC**) and the New Divider Selection Request (**NDIV**) bits are used to select the system clock source and clock frequency divider that will be used by the CPU and peripherals (see the tables below).

When new values are written into NOSC and/or NDIV, the current oscillator selection will continue to operate as the system clock while waiting for the new source to indicate that it is ready. Writes to NDIV without changing the clock source (e.g., changing the HFINTOSC frequency from 1 MHz to 2 MHz) are handled in the same manner as a clock switch.

When the new oscillator selection is ready, the New Oscillator is Ready (**NOSCR**) bit and the Clock Switch Interrupt Flag (CSWIF) are set by module hardware. If the Clock Switch Interrupt Enable (CSWIE) bit is set (CSWIE = 1), an interrupt will be generated when CSWIF is set. Additionally, the Oscillator Ready (**ORDY**) bit can be polled to determine that the clock switch has completed and the new oscillator source has replaced the old source as the system clock.



Important: The CSWIF interrupt does not wake the device from Sleep.

Table 11-2. NOSC/COSC Clock Source Selection Table

NOSC / COSC	Clock Source
111	EXTOSC ⁽¹⁾
110	HFINTOSC ⁽²⁾
101	LFINTOSC
100	SOSC
011	Reserved
010	EXTOSC + 4xPLL ⁽³⁾
001	Reserved
000	Reserved

Notes:

- EXTOSC is configured via the FEXTOSC Configuration bits.
- HFINTOSC frequency is determined by the **FRQ** bits.
- EXTOSC must meet the PLL specifications (see the data sheet Electrical Specifications).

Table 11-3. NDIV/CDIV Clock Divider Selection Table

NDIV / CDIV	Clock Divider
1111-1010	Reserved
1001	512
1000	256
0111	128
0110	64
0101	32
0100	16
0011	8
0010	4
0001	2
0000	1

11.2.2 COSC and CDIV Bits

The Current Oscillator Source Select (**COSC**) bits and the Current Divider Select (**CDIV**) bits indicate the current oscillator source and clock divider, respectively. When a new oscillator or divider is requested via the **NOSC/NDIV** bits, the **COSC** and **CDIV** bits remain unchanged until the clock switch actually occurs. When the switch actually occurs, hardware copies the **NOSC** and **NDIV** values into **COSC** and **CDIV**, the Oscillator Ready (**ORDY**) bit is set, and the **NOSCR** bit is cleared by hardware, indicating that the clock switch is complete.

11.2.3 CSWHOLD

When the system oscillator changes frequencies, peripherals using the system clock may be affected. For example, if the I²C module is actively using the system clock as its Serial Clock (SCL) time base, changing the system clock frequency will change the SCL frequency. The Clock Switch Hold (**CSWHOLD**) bit can be used to suspend a requested clock switch. In this example, software can request a new clock source, use the **CSWHOLD** bit to suspend the switch, wait for the I²C bus to become Idle, then reconfigure the SCL frequency based on the new clock source. Once the I²C has been reconfigured, software can use **CSWHOLD** to complete the clock switch without causing any issues with the I²C bus.

When **CSWHOLD** is set (**CSWHOLD** = 1), a write to **NOSC** and/or **NDIV** is accepted, but the clock switch is suspended and does not automatically complete. While the switch is suspended, code execution continues using the old (current) clock source. Module hardware will still enable the new oscillator selection and set the **NOSCR** bit. Once the **NOSCR** bit is set, software may either:

- clear **CSWHOLD** so that the clock switch can complete, or
- copy the Current Oscillator Source Select (**COSC**) value into **NOSC** to abandon the clock switch.

When **CSWHOLD** is clear (**CSWHOLD** = 0), the clock switch will occur when the **NOSCR** bit is set. When **NOSCR** is set, the **CSWIF** is also set, and if **CSWIE** is set, the generated interrupt will be serviced using the new oscillator.

11.2.4 PLL Input Switch

Switching between the PLL and any non-PLL source is handled in the same manner as any other clock source change.

When the **NOSC** selects a source with a PLL, the system continues to operate using the current oscillator until the new oscillator is ready. When the new source is ready, the associated Status bit in the Oscillator Status (**OSCSTAT**) register is set, and once the PLL is locked and ready for use, the PLL is Ready (**PLL**R) bit is set. Once both the source and PLL are ready, the switch will complete.

11.2.5 Clock Switch and Sleep

If the **NOSC/NDIV** bits are written with new values and the device is put to Sleep before the clock switch completes, the switch will not take place and the device will enter Sleep mode.

When the device wakes up from Sleep and **CSWHOLD** is clear (**CSWHOLD** = 0), the clock switch will complete and the device will wake with the new clock active, setting **CSWIF**.

When the device wakes from Sleep and **CSWHOLD** is set (**CSWHOLD** = 1), the device will wake up with the old clock active, and the new clock source will be requested again.

If Doze mode is in effect, the clock switch occurs on the next clock cycle regardless of whether or not the CPU is active during that clock cycle.

Figure 11-7. Clock Switch (CSWHOLD = 0)

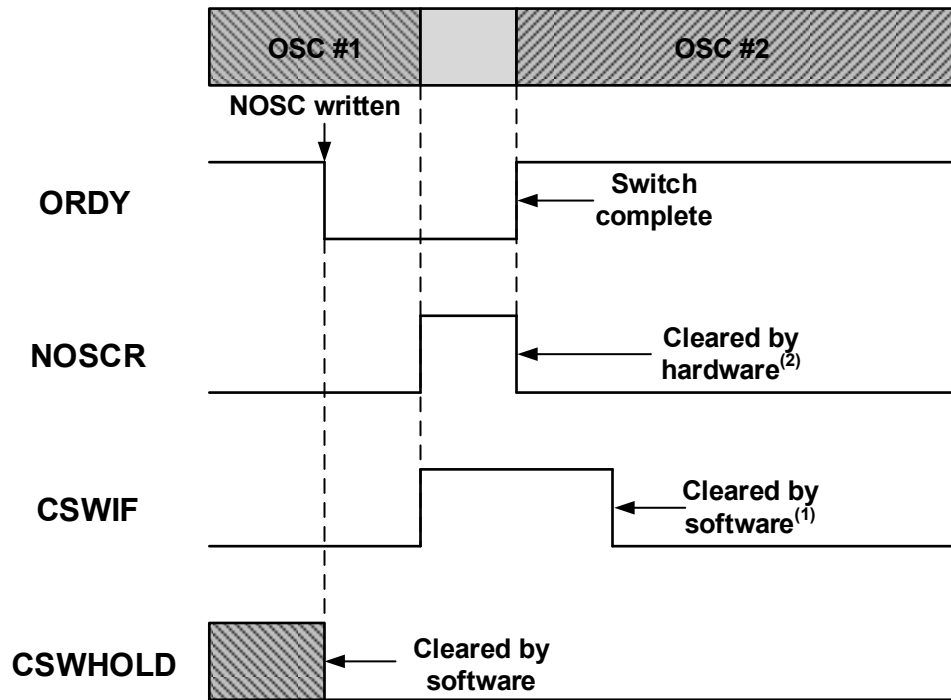

Notes:

1. CSWIF is asserted coincident with NOSCR; interrupt is serviced at OSC#2 speed.
2. The assertion of NOSCR may not be seen by the user as it is only set for the duration of the switch.

Figure 11-8. Clock Switch (CSWHOLD = 1)

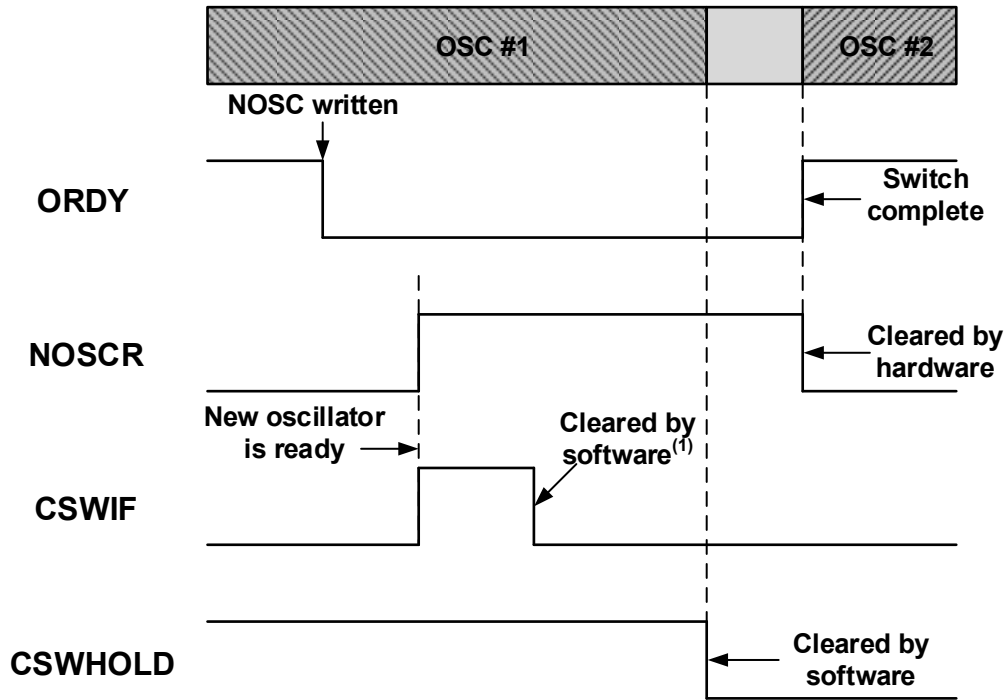

Note:

1. CSWIF may be cleared before or after clearing CSWHOLD.

Figure 11-9. Clock Switch Abandoned

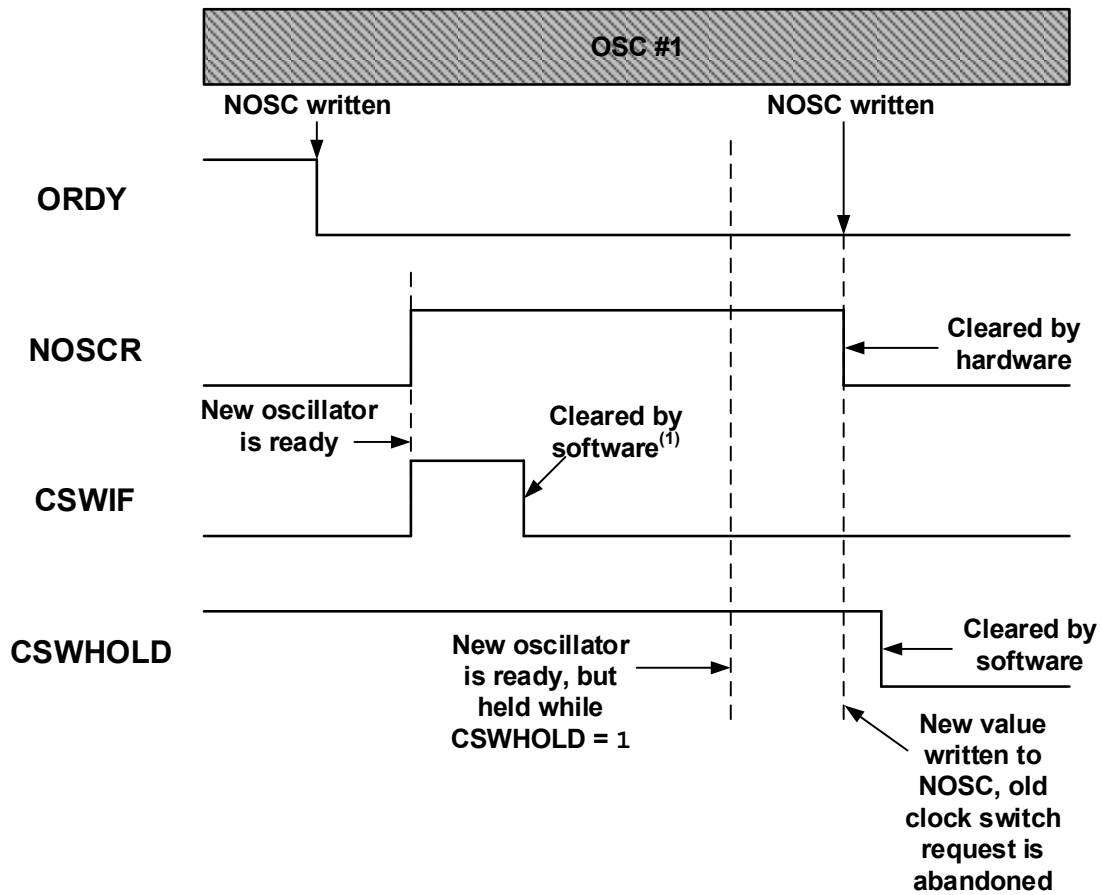
**Note:**

1. CSWIF may be cleared before or after rewriting **NOSC**; CSWIF is not automatically cleared.

11.3 Fail-Safe Clock Monitor (FSCM)

The Fail-Safe Clock Monitor (FSCM) allows the device to continue operating if the external oscillator fails. The FSCM is applicable to all external Oscillator modes. The FSCM is enabled by setting the Fail-Safe Clock Monitor Enable (FCMEN) Configuration bit.

The figure below shows the FSCM block diagram.

Figure 11-10. FSCM Block Diagram

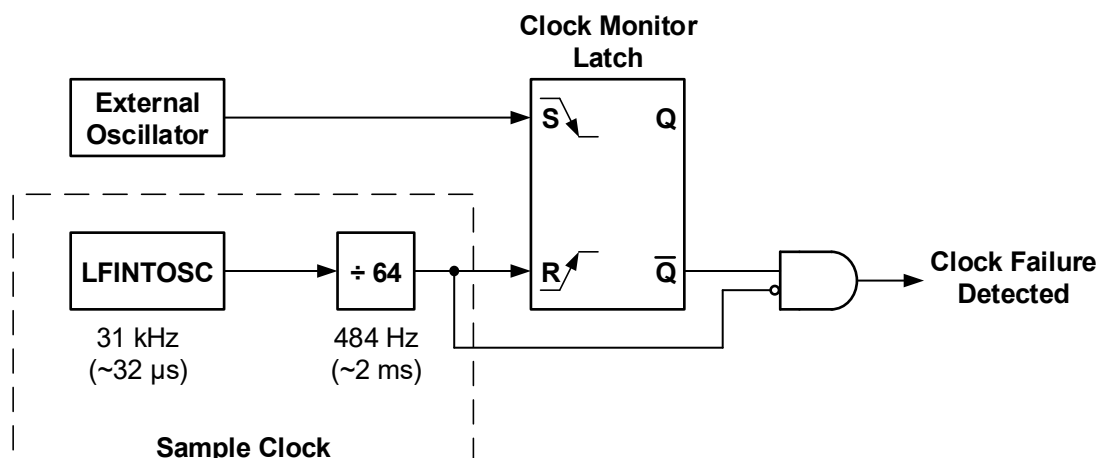

11.3.1 Fail-Safe Detection

The FSCM detects a failed oscillator by comparing the external oscillator to the FSCM sample clock. The sample clock is generated by dividing the LFINTOSC by 64. The fail detector block contains a latch that is set upon each falling edge of the external clock. The latch is cleared on the rising edge of the sample clock. A failure is detected when a half-period of the sample clock elapses before the external clock goes low.

11.3.2 Fail-Safe Operation

When the external clock fails, the FSCM overwrites the **NOSC/COSC** bits to select the HFINTOSC and sets the Oscillator Fail Interrupt Flag (OSFIF) bit of the PIR registers. If the Oscillator Fail Interrupt Enable (OSFIE) bit is set, an interrupt will be generated when OSFIF is set. The frequency of HFINTOSC depends on the previous state of the **FRQ** bits and the **NDIV/CDIV** bits.

Once a failure is detected, software can take steps to mitigate the effects of a failed oscillator. The system clock will continue to be sourced from the HFINTOSC until the external oscillator is restarted. Once the external source is operational, software can switch back to the external oscillator via the **NOSC/NDIV** bits.

11.3.3 Fail-Safe Condition Clearing

The Fail-Safe condition is cleared after a device Reset, execution of a **SLEEP** instruction, or a change to the **NOSC/NDIV** bits. When switching to the external oscillator or PLL, the Oscillator Start-up Timer (OST) is restarted. While the OST is running, the device continues to run from HFINTOSC. When the OST expires, the Fail-Safe condition is cleared after successfully switching to the external clock source.



Important: Software must clear the OSFIF bit before switching to the external oscillator. If the Fail-Safe condition still exists, the OSFIF bit will be set again by module hardware.

11.3.4 Reset or Wake-Up from Sleep

The FSCM is designed to detect an oscillator failure after the OST has expired. The OST is used after waking up from Sleep or after any type of Reset, when in either LP, XT or HS mode. If the device is using the EC mode, the FSCM will be active as soon as the Reset or wake-up event has completed.

11.4 Active Clock Tuning (ACT)

Many applications, such as those using UART communication, require an oscillator with an accuracy of $\pm 1\%$ over the full temperature and voltage range. To meet this level of accuracy, the Active Clock Tuning (ACT) feature utilizes the SOSC frequency of 32.768 kHz to adjust the frequency of the HFINTOSC over voltage and temperature.



Important: Active Clock Tuning requires the use of a 32.768 kHz external oscillator connected to the SOSC/SOSCO pins.

Active Clock Tuning is enabled via the Active Clock Tuning Enable (ACTEN) bit. When ACTEN is set (ACTEN = 1), the ACT module uses the SOSC time base to measure the HFINTOSC frequency and uses the HFINTOSC Frequency Tuning (TUN) bits to adjust the HFINTOSC frequency. When ACTEN is clear (ACTEN = 0), the ACT feature is disabled, and user software can utilize the TUN bits to adjust the HFINTOSC frequency.



Important: When the ACT feature is enabled, the TUN bits are controlled directly through module hardware and become read-only bits to user software. Writes to the TUN bits when the ACT feature is enabled are ignored.

The figure below shows the Active Clock Tuning block diagram.

Figure 11-11. Active Clock Tuning (ACT) Block Diagram

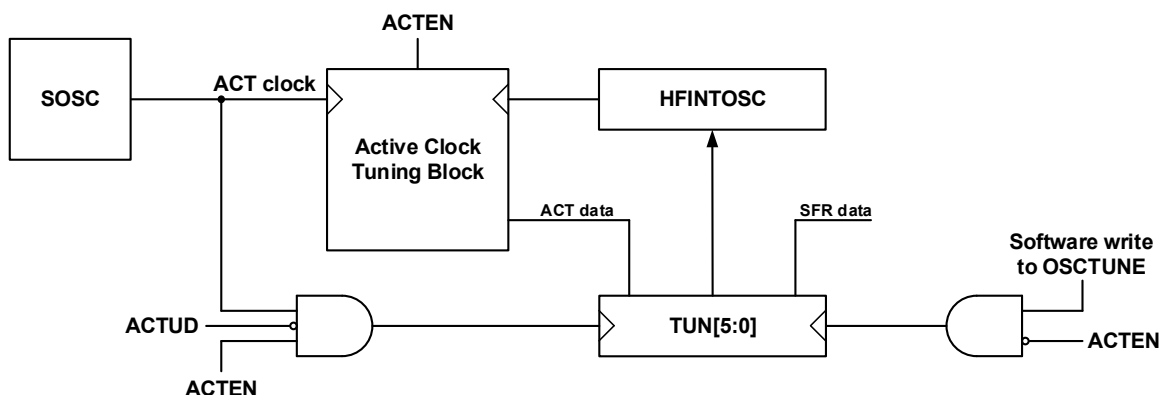

11.4.1 ACT Lock Status

The Active Clock Tuning Lock Status (ACTLOCK) bit can be used to determine when the HFINTOSC has been tuned. When ACTLOCK is set (ACTLOCK = 1), the HFINTOSC frequency has been locked to within $\pm 1\%$ of the nominal frequency. When ACTLOCK is clear (ACTLOCK = 0), the following conditions may be true:

- The HFINTOSC frequency has not been locked to within $\pm 1\%$
- A device Reset occurred
- The ACT feature is disabled



Important: The ACTLOCK bit is read-only. Writes to ACTLOCK are ignored.

11.4.2 ACT Out-of-Range Status

When Active Clock Tuning is enabled, module hardware uses the TUN bits to achieve high accuracy levels. If the module requires a TUN value outside of its range, the ACT Out-of-Range Status (ACTORS) bit is set by hardware (ACTORS = 1).

The ACTORS bit will be set when:

- The HFINTOSC is tuned to its lowest frequency as determined by the TUN bits and may require a value lower than the TUN bits can provide to achieve accuracy within $\pm 1\%$.
- The HFINTOSC is tuned to its highest frequency as determined by the TUN bits and may require a value higher than the TUN bits can provide to achieve accuracy within $\pm 1\%$.

When an ACT out-of-range event occurs, the HFINTOSC will continue to use the last TUN value until the HFINTOSC frequency returns to the tunable range. Once the HFINTOSC returns to the tunable range, module hardware clears the ACTORS bit.



Important: The ACTORS bit is read-only. Writes to ACTORS are ignored.

11.4.3 ACT Update Disable

When Active Clock Tuning is enabled, the OSCTUNE register is continuously updated every ACT clock cycle. The ACT Update Disable (ACTUD) bit can be used to suspend updates to the OSCTUNE register. When ACTUD is set (ACTUD = 1), updates to OSCTUNE are suspended, although the module continues to operate. The last value written to OSCTUNE is used for tuning, and the ACTLOCK bit is continually updated for each ACT cycle. When ACTUD is clear (ACTUD = 0), the module updates OSCTUNE register every ACT cycle.

11.4.4 ACT Interrupts

When Active Clock Tuning is enabled (ACTEN = 1) and either the ACTLOCK or ACTORS bits change state (e.g., from a Locked to an Unlocked state), the ACT Interrupt Flag (ACTIF) of the PIR registers is set (ACTIF = 1). If the ACT Interrupt Enable (ACTIE) bit is set (ACTIE = 1), an interrupt will be generated when ACTIF becomes set. No interrupts are generated for each OSCTUNE update unless the update results in a change of Lock status or Out-of-Range status.

11.5 Register Definitions: Oscillator Module

11.5.1 ACTCON

Name: ACTCON

Offset: 0x0294

Active Clock Tuning Control Register

Bit	7	6	5	4	3	2	1	0
	ACTEN	ACTUD			ACTLOCK		ACTORS	
Access	R/W	R/W			R		R	
Reset	0	0			0		0	

Bit 7 – ACTEN Active Clock Tuning Enable

Value	Description
1	ACT enabled: HFINTOSC tuning is controlled by the ACT
0	ACT disabled: HFINTOSC tuning is controlled by the OSCTUNE register via user software

Bit 6 – ACTUD Active Clock Tuning Update Disable

Value	Condition	Description
1	ACTEN = 1	Updates to the OSCTUNE register from ACT hardware are disabled
0	ACTEN = 1	Updates to the OSCTUNE register from ACT hardware are allowed
x	ACTEN = 0	Updates to the OSCTUNE register through user software are allowed

Bit 3 – ACTLOCK Active Clock Tuning Lock Status

Value	Description
1	Locked: HFINTOSC is within $\pm 1\%$ of its nominal value
0	Not locked: HFINTOSC may or may not be within $\pm 1\%$ of its nominal value

Bit 1 – ACTORS Active Clock Tuning Out-of-Range Status

Value	Description
1	Value required for tuning is outside of the OSCTUNE range
0	Value required for tuning is within the OSCTUNE range

11.5.2 OSCCON1

Name: OSCCON1
Offset: 0x028D

Oscillator Control Register 1

Bit	7	6	5	4	3	2	1	0
		NOSC[2:0]			NDIV[3:0]			
Access		R/W	R/W	R/W	R/W	R/W	R/W	R/W
Reset		f	f	f	q	q	q	q

Bits 6:4 – NOSC[2:0] New Oscillator Source Request^(1,2,3)
 Requests a new oscillator source per the [NOSC/COSC Clock Source Selection Table](#)

Bits 3:0 – NDIV[3:0] New Divider Selection Request
 Requests the new post-scaler division ratio per the [NDIV/CDIV Clock Divider Selection Table](#)

Notes:

1. The default value is determined by the RSTOSC Configuration bits. See the Reset Oscillator (RSTOSC) selection table for RSTOSC selections.
2. If NOSC is written with a reserved value, the operation is ignored and neither NOSC nor NDIV is written.
3. When CSWEN = 0, these bits are read-only and cannot be changed from the RSTOSC value.

11.5.3 OSCCON2

Name: OSCCON2
Offset: 0x028E

Oscillator Control Register 2

Bit	7	6	5	4	3	2	1	0
		COSC[2:0]			CDIV[3:0]			
Access		R	R	R	R	R	R	R
Reset		f	f	f	f	f	f	f

Bits 6:4 – COSC[2:0] Current Oscillator Source Select (read-only)⁽¹⁾
 Indicates the current oscillator source per the [NOSC/COSC Clock Source Selection Table](#)

Bits 3:0 – CDIV[3:0] Current Divider Select (read-only)
 Indicates the current post-scaler divider ratio per the [NDIV/CDIV Clock Divider Table](#)

Note:

1. The RSTOSC value is the value present when user code execution begins. Refer to the RSTOSC configuration bits or the RSTOSC selection table for the Reset Oscillator selections.

11.5.4 OSCCON3

Name: OSCCON3

Offset: 0x028F

Oscillator Control Register 3

Bit	7	6	5	4	3	2	1	0
	CSWHOLD	SOSCPWR		ORDY	NOSCR			
Access	R/W/HC	R/W		R	R			
Reset	0	1		0	0			

Bit 7 – CSWHOLD Clock Switch Hold Control

Value	Description
1	Clock switch (and interrupt) will hold when the oscillator selected by NOSCR is ready
0	Clock switch will proceed when the oscillator selected by NOSCR is ready

Bit 6 – SOSCPWR Secondary Oscillator Power Mode Select

Value	Description
1	Secondary Oscillator operates in High-Power mode
0	Secondary Oscillator operates in Low-Power mode

Bit 4 – ORDY Oscillator Ready (read-only)

Value	Description
1	OSCCON1 = OSCCON2; the current system clock is the clock specified by NOSCR
0	A clock switch is in progress

Bit 3 – NOSCR New Oscillator is Ready (read-only)⁽¹⁾

Value	Description
1	A clock switch is in progress and the oscillator selected by NOSCR indicates a 'ready' condition
0	A clock switch is not in progress, or the NOSCR-selected oscillator is not ready

Note:

1. If CSWHOLD = 0, the user may not see this bit set (NOSCR = 1). When the oscillator becomes ready, there may be a delay of one instruction cycle before NOSCR is set. The clock switch occurs in the next instruction cycle and NOSCR is cleared.

11.5.5 OSCTUNE

Name: OSCTUNE

Offset: 0x0292

HFINTOSC Frequency Tuning Register

Bit	7	6	5	4	3	2	1	0
			TUN[5:0]					
Access			R/W	R/W	R/W	R/W	R/W	R/W
Reset			0	0	0	0	0	0

Bits 5:0 – TUN[5:0] HFINTOSC Frequency Tuning

TUN	Condition
01 1111	Maximum frequency
•	•
•	•
•	•
00 0000	Center frequency. Oscillator is operating at the selected nominal frequency. (Default value)
•	•
•	•
•	•
10 0000	Minimum frequency

11.5.6 OSCFRQ**Name:** OSCFRQ**Offset:** 0x0293

HFINTOSC Frequency Selection Register

Bit	7	6	5	4	3	2	1	0
						FRQ[2:0]		
Access						R/W	R/W	R/W
Reset						0	0	0

Bits 2:0 – FRQ[2:0] HFINTOSC Frequency Selection

FRQ	Nominal Freq (MHz)
111–110	Reserved
101	32
100	16
011	8
010	4
001	2
000	1

11.5.7 OSCSTAT

Name: OSCSTAT
Offset: 0x0290

Oscillator Status Register

Bit	7	6	5	4	3	2	1	0
	EXTOR	HFOR	MFOR	LFOR	SOR	ADOR	SFOR	PLLR
Access	R	R	R	R	R	R	R	R
Reset	0	0	0	0	0	0	0	0

Bit 7 – EXTOR External Oscillator Ready

Value	Description
1	The External oscillator is ready for use
0	The External oscillator is not enabled, or it is not ready for use

Bit 6 – HFOR HFINTOSC Ready

Value	Description
1	The HFINTOSC is ready for use
0	The HFINTOSC is not enabled, or it is not ready for use

Bit 5 – MFOR MFINTOSC Ready

Value	Description
1	The MFINTOSC is ready for use
0	The MFINTOSC is not enabled, or it is not ready for use

Bit 4 – LFOR LFINTOSC Ready

Value	Description
1	The LFINTOSC is ready for use
0	The LFINTOSC is not enabled, or it is not ready for use

Bit 3 – SOR Secondary Oscillator (SOSC) Ready

Value	Description
1	The Secondary oscillator is ready for use
0	The Secondary oscillator is not enabled, or it is not ready for use

Bit 2 – ADOR ADCRC Oscillator Ready

Value	Description
1	The ADCRC oscillator is ready for use
0	The ADCRC oscillator is not enabled, or it is not ready for use

Bit 1 – SFOR SFINTOSC Oscillator Ready

Value	Description
1	The SFINTOSC oscillator is ready for use
0	The SFINTOSC oscillator is not enabled, or it is not ready for use

Bit 0 – PLLR PLL is Ready

Value	Description
1	The PLL is ready for use
0	The PLL is not enabled, the required input source is not ready, or the PLL is not locked

11.5.8 OSCEN

Name: OSCEN
Offset: 0x0291

Oscillator Enable Register

Bit	7	6	5	4	3	2	1	0
	EXTOEN	HFOEN	MFOEN	LFOEN	SOSCEN	ADOEN		PLLEN
Access	R/W	R/W	R/W	R/W	R/W	R/W		R/W
Reset	0	0	0	0	0	0		0

Bit 7 – EXTOEN External Oscillator Enable

Value	Description
1	EXTOSC is explicitly enabled, operating as specified by FEXTOSC
0	EXTOSC can be enabled by a peripheral request

Bit 6 – HFOEN HFINTOSC Enable

Value	Description
1	HFINTOSC is explicitly enabled, operating as specified by OSCFRQ
0	HFINTOSC can be enabled by a peripheral request

Bit 5 – MFOEN MFINTOSC Enable

Value	Description
1	MFINTOSC is explicitly enabled
0	MFINTOSC can be enabled by a peripheral request

Bit 4 – LFOEN LFINTOSC Enable

Value	Description
1	LFINTOSC is explicitly enabled
0	LFINTOSC can be enabled by a peripheral request

Bit 3 – SOSCEN Secondary Oscillator Enable

Value	Description
1	SOSC is explicitly enabled, operating as specified by SOSCPWR
0	SOSC can be enabled by a peripheral request

Bit 2 – ADOEN ADCRC Oscillator Enable

Value	Description
1	ADCRC is explicitly enabled
0	ADCRC may be enabled by a peripheral request

Bit 0 – PLLEN PLL Enable⁽¹⁾

Value	Description
1	EXTOSC multiplied by the 4x system PLL is used by a peripheral request
0	EXTOSC is used by a peripheral request

Note:

1. This bit only controls external clock source supplied to the peripherals and has no effect on the system clock.

11.6 Register Summary - Oscillator Module

Offset	Name	Bit Pos.	7	6	5	4	3	2	1	0
0x00 ...	Reserved									
0x028C										
0x028D	OSCCON1	7:0			NOSC[2:0]			NDIV[3:0]		
0x028E	OSCCON2	7:0			COSC[2:0]			CDIV[3:0]		
0x028F	OSCCON3	7:0	CSWHOLD	SOSCPWR		ORDY	NOSCR			
0x0290	OSCSTAT	7:0	EXTOR	HFOR	MFOR	LFOR	SOR	ADOR	SFOR	PLLR
0x0291	OSCEN	7:0	EXTOEN	HFOEN	MFOEN	LFOEN	SOSCEN	ADOEN		PLLEN
0x0292	OSCTUNE	7:0			TUN[5:0]					
0x0293	OSCFRQ	7:0							FRQ[2:0]	
0x0294	ACTCON	7:0	ACTEN	ACTUD			ACTLOCK		ACTORS	

12. INT - Interrupts

12.1 Overview

The interrupt feature allows certain events to preempt normal program flow. Firmware is used to determine the source of the interrupt and act accordingly. Some interrupts can be configured to wake the MCU from Sleep mode.

Many peripherals can produce interrupts. Refer to the corresponding chapters for details.

A block diagram of the interrupt logic is shown in [Figure 12-1](#).

Figure 12-1. Interrupt Logic

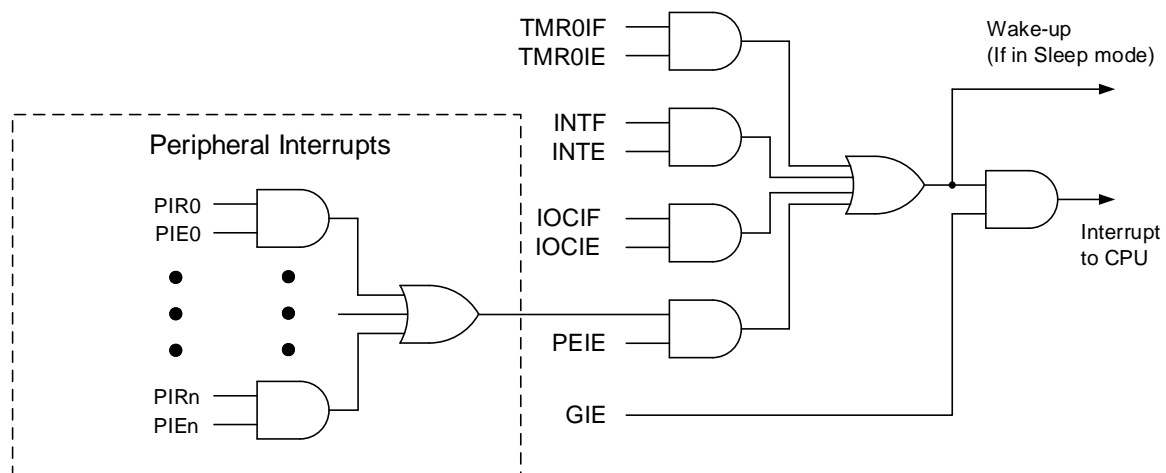

12.2 INTCON Register

The Interrupt Control ([INTCON](#)) register is readable and writable, and contains the Global Interrupt Enable (GIE), Peripheral Interrupt Enable (PEIE) and External Interrupt Edge Select (INTEDG) bits.

12.3 PIE Registers

The Peripheral Interrupt Enable (PIE) registers contain the individual enable bits for the peripheral interrupts. Due to the number of peripheral interrupt sources, there are seven PIE registers in the PIC16F181 family.

12.4 PIR Registers

The Peripheral Interrupt Request (PIR) registers contain the individual flag bits for the peripheral interrupts. Due to the number of peripheral interrupt sources, there are seven PIR registers.

12.5 Operation

Interrupts are disabled upon any device Reset. They are enabled by setting the following bits:

- [GIE](#) bit
- [PEIE](#) bit (if the Interrupt Enable bit of the interrupt event is contained in the PIE registers)
- Interrupt Enable bit(s) for the specific interrupt event(s)

The PIR registers record individual interrupts via interrupt flag bits. Interrupt flag bits will be set, regardless of the status of the GIE, PEIE and individual interrupt enable bits.

The following events happen when an interrupt event occurs while the GIE bit is set:

- Current prefetched instruction is flushed
- GIE bit is cleared
- Current Program Counter (PC) is pushed onto the stack
- Critical registers are automatically saved to the shadow registers (see the “**Automatic Context Saving**” section)
- PC is loaded with the interrupt vector 0004h

The firmware within the Interrupt Service Routine (ISR) may determine the source of the interrupt by polling the interrupt flag bits. The interrupt flag bits must be cleared before exiting the ISR to avoid repeated interrupts. Because the GIE bit is cleared, any interrupt that occurs while executing the ISR will be recorded through its interrupt flag, but will not cause the processor to redirect to the interrupt vector.

The `RETFIE` instruction exits the ISR by popping the previous address from the stack, restoring the saved context from the shadow registers and setting the GIE bit.

For additional information on a specific interrupts operation, refer to its peripheral chapter.



Important:

1. Individual interrupt flag bits are set, regardless of the state of any other enable bits.
2. All interrupts will be ignored while the GIE bit is cleared. Any interrupt occurring while the GIE bit is clear will be serviced when the GIE bit is set again.

12.6 Interrupt Latency

Interrupt latency is defined as the time from when the interrupt event occurs to the time code execution at the interrupt vector begins. The interrupt is sampled during Q1 of the instruction cycle. The actual interrupt latency then depends on the instruction that is executing at the time the interrupt is detected. See the following figures for more details.

Figure 12-2. Interrupt Latency

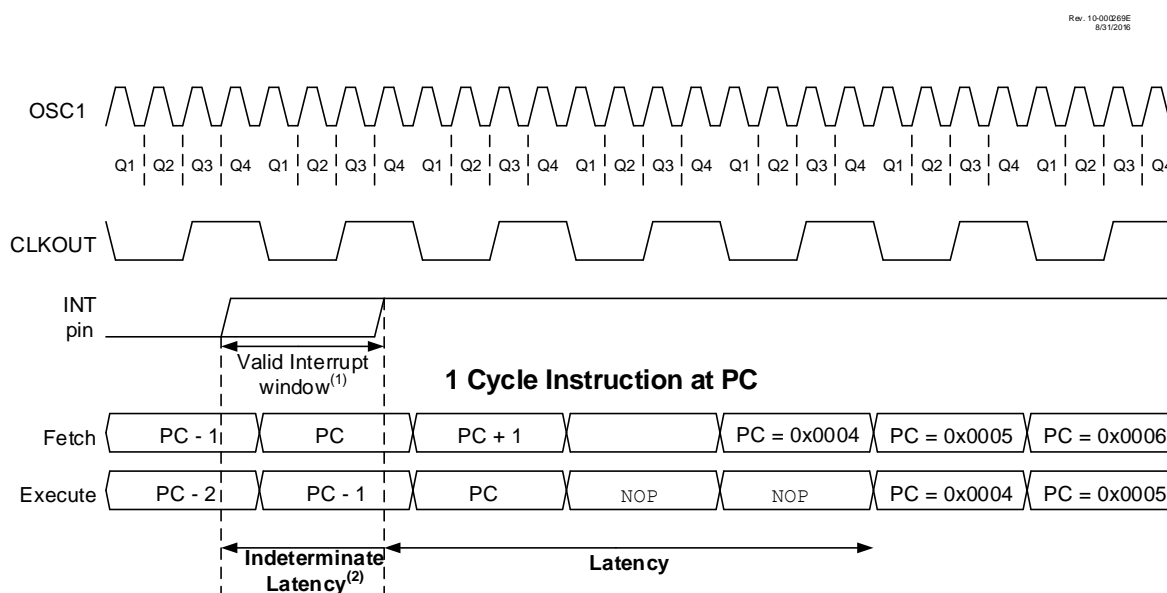

Notes:

1. An interrupt may occur at any time during the interrupt window.
2. Since an interrupt may occur any time during the interrupt window, the actual latency can vary.

Figure 12-3. INT Pin Interrupt Timing

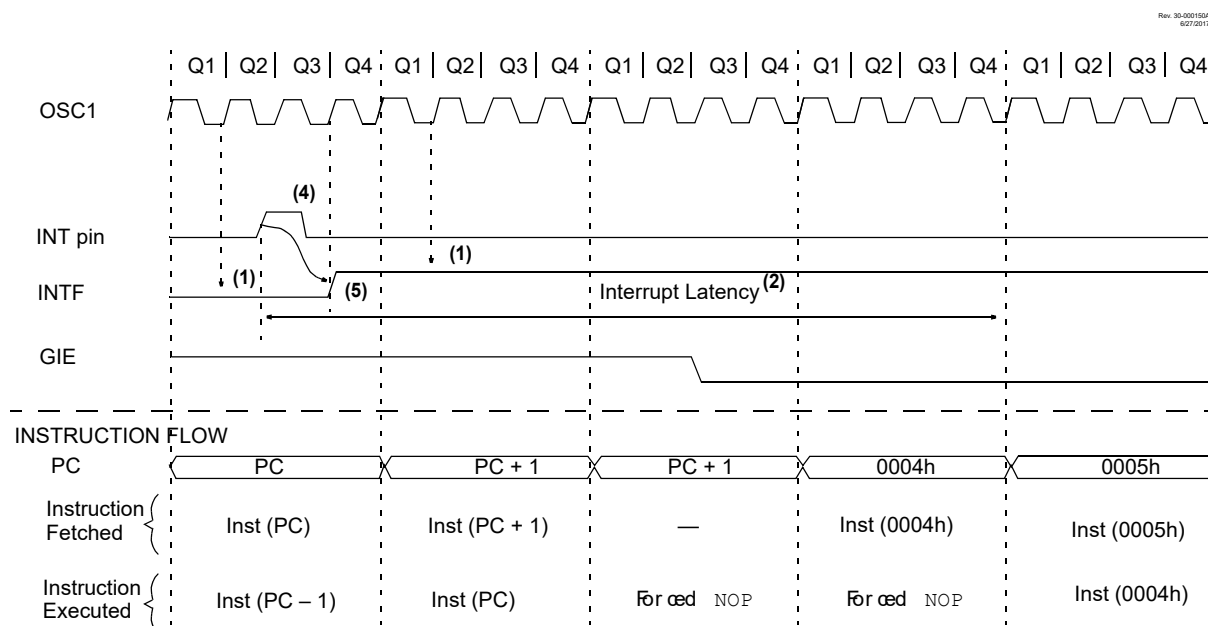

Notes:

1. INTF flag is sampled here (every Q1).
2. Asynchronous interrupt latency = 3-5 T_{CY} . Synchronous latency = 3-4 T_{CY} , where T_{CY} = instruction cycle time. Latency is the same whether Inst (PC) is a single cycle or a two-cycle instruction.
3. For minimum width of INT pulse, refer to AC specifications in the **“Electrical Specifications”** chapter.
4. INTF may be set any time during the Q4-Q1 cycles.

12.7 Interrupts During Sleep

Interrupts can be used to wake from Sleep. To wake from Sleep, the peripheral must be able to operate without the system clock. The interrupt source must have the appropriate Interrupt Enable bit(s) set prior to entering Sleep.

On waking from Sleep, if the GIE bit is also set, the processor will branch to the interrupt vector. Otherwise, the processor will continue executing instructions after the SLEEP instruction. The instruction directly after the SLEEP instruction will always be executed before branching to the ISR.

12.8 INT Pin

The INT pin can be used to generate an asynchronous edge-triggered interrupt. This interrupt is enabled by setting the External Interrupt Enable (INTE) bit. The External Interrupt Edge Select (INTEDG) bit determines on which edge the interrupt will occur. When the INTEDG bit is set, the rising edge will cause the interrupt. When the INTEDG bit is clear, the falling edge will cause the interrupt. The External Interrupt Flag (INTF) bit will be set when a valid edge appears on the INT pin. If the GIE and INTE bits are also set, the processor will redirect program execution to the interrupt vector.

12.9 Automatic Context Saving

Upon entering an interrupt, the return PC address is saved on the stack. Additionally, the following registers are automatically saved in the shadow registers:

- WREG register
- STATUS register (except for $\overline{\text{TO}}$ and $\overline{\text{PD}}$)
- BSR register
- FSR registers
- PCLATH register

Upon exiting the Interrupt Service Routine, these registers are automatically restored. Any modifications to these registers during the ISR will be lost. If modifications to any of these registers are desired, the corresponding shadow register may be modified and the value will be restored when exiting the ISR. The shadow registers are available in Bank 63 and are readable and writable. Depending on the user's application, other registers may also need to be saved.

12.10 Register Definitions: Interrupt Control

12.10.1 INTCON

Name: INTCON
Offset: 0x000B

Interrupt Control Register

Bit	7	6	5	4	3	2	1	0
	GIE	PEIE						INTEDG
Access	R/W	R/W						R/W
Reset	0	0						1

Bit 7 – GIE Global Interrupt Enable

Value	Description
1	Enables all active interrupts
0	Disables all interrupts

Bit 6 – PEIE Peripheral Interrupt Enable

Value	Description
1	Enables all active peripheral interrupts
0	Disables all peripheral interrupts

Bit 0 – INTEDG External Interrupt Edge Select

Value	Description
1	Interrupt on rising edge of INT pin
0	Interrupt on falling edge of INT pin

Note: Interrupt flag bits are set when an Interrupt condition occurs, regardless of the state of its corresponding enable bit or the Global Enable bit. User software may ensure the appropriate interrupt flag bits are clear prior to enabling an interrupt. This feature allows for software polling.

12.10.2 PIE0

Name: PIE0
Offset: 0x0096

Peripheral Interrupt Enable Register 0

Bit	7	6	5	4	3	2	1	0
			TMR0IE	IOCIE				INTE
Access			R/W	R/W				R/W
Reset			0	0				0

Bit 5 – TMR0IE Timer0 Interrupt Enable

Value	Description
1	TMR0 interrupts are enabled
0	TMR0 interrupts are disabled

Bit 4 – IOCIE Interrupt-on-Change Enable

Value	Description
1	IOC interrupts are enabled
0	IOC interrupts are disabled

Bit 0 – INTE External Interrupt Enable⁽¹⁾

Value	Description
1	External interrupts are enabled
0	External interrupts are disabled

Notes:

1. The External Interrupt INT pin is selected by INTPPS.
2. Bit PEIE in the INTCON register must be set to enable any peripheral interrupt controlled by registers PIE1 through PIE6. Interrupt sources controlled by the PIE0 register do not require the PEIE bit to be set to allow interrupt vectoring (when the GIE bit in the INTCON register is set).

12.10.3 PIE1

Name: PIE1
Offset: 0x0097

Peripheral Interrupt Enable Register 1

Bit	7	6	5	4	3	2	1	0
	TMR1GIE	TMR1IE	OSFIE	CSWIE	ACTIE	SCANIE	CRCIE	NVMIE
Access	R/W	R/W	R/W	R/W	R/W	R/W	R/W	R/W
Reset	0	0	0	0	0	0	0	0

Bit 7 – TMR1GIE TMR1 Gate Interrupt Enable

Value	Description
1	TMR1 Gate interrupts are enabled
0	TMR1 Gate interrupts are disabled

Bit 6 – TMR1IE TMR1 Interrupt Enable

Value	Description
1	TMR1 interrupts are enabled
0	TMR1 interrupts are disabled

Bit 5 – OSFIE Oscillator Failure Interrupt Enable

Value	Description
1	Oscillator Failure interrupts are enabled
0	Oscillator Failure interrupts are disabled

Bit 4 – CSWIE Clock Switch Interrupt Enable

Value	Description
1	Clock Switch interrupts are enabled
0	Clock Switch interrupts are disabled

Bit 3 – ACTIE Active Clock Tuning Interrupt Enable

Value	Description
1	Active Clock Tuning interrupts are enabled
0	Active Clock Tuning interrupts are disabled

Bit 2 – SCANIE Memory Scanner Interrupt Enable

Value	Description
1	Memory Scanner interrupts are enabled
0	Memory Scanner interrupts are disabled

Bit 1 – CRCIE CRC Interrupt Enable

Value	Description
1	CRC interrupts are enabled
0	CRC interrupts are disabled

Bit 0 – NVMIE NVM Interrupt Enable

Value	Description
1	NVM interrupts are enabled
0	NVM interrupts are disabled

Note: Bit PEIE of the INTCON register must be set to enable any peripheral interrupt controlled by registers PIE1 through PIE6.

12.10.4 PIE2

Name: PIE2
Offset: 0x0098

Peripheral Interrupt Enable Register 2

Bit	7	6	5	4	3	2	1	0
		CCP2IE	CCP1IE		TMR4IE	TMR2IE	TMR3GIE	TMR3IE
Access		R/W	R/W		R/W	R/W	R/W	R/W
Reset		0	0		0	0	0	0

Bit 6 – CCP2IE CCP2 Interrupt Enable

Value	Description
1	CCP2 interrupts are enabled
0	CCP2 interrupts are disabled

Bit 5 – CCP1IE CCP1 Interrupt Enable

Value	Description
1	CCP1 interrupts are enabled
0	CCP1 interrupts are disabled

Bit 3 – TMR4IE TMR4 Interrupt Enable

Value	Description
1	TMR4 interrupts are enabled
0	TMR4 interrupts are disabled

Bit 2 – TMR2IE TMR2 Interrupt Enable

Value	Description
1	TMR2 interrupts are enabled
0	TMR2 interrupts are disabled

Bit 1 – TMR3GIE TMR3 Gate Interrupt Enable

Value	Description
1	TMR3 Gate interrupts are enabled
0	TMR3 Gate interrupts are disabled

Bit 0 – TMR3IE TMR3 Interrupt Enable

Value	Description
1	TMR3 interrupts are enabled
0	TMR3 interrupts are disabled

Note: Bit PEIE of the INTCON register must be set to enable any peripheral interrupt controlled by registers PIE1 through PIE6.

12.10.5 PIE3

Name: PIE3
Offset: 0x0099

Peripheral Interrupt Enable Register 3

Bit	7	6	5	4	3	2	1	0
					PWM2IE	PWM2PIE	PWM1IE	PWM1PIE
Access					R/W	R/W	R/W	R/W
Reset					0	0	0	0

Bit 3 – PWM2IE PWM2 Parameter Interrupt Enable

Value	Description
1	PWM2 Parameter interrupts are enabled
0	PWM2 Parameter interrupts are disabled

Bit 2 – PWM2PIE PWM2 Period Interrupt Enable

Value	Description
1	PWM2 Period interrupts are enabled
0	PWM2 Period interrupts are disabled

Bit 1 – PWM1IE PWM1 Parameter Interrupt Enable

Value	Description
1	PWM1 Parameter interrupts are enabled
0	PWM1 Parameter interrupts are disabled

Bit 0 – PWM1PIE PWM1 Period Interrupt Enable

Value	Description
1	PWM1 Period interrupts are enabled
0	PWM1 Period interrupts are disabled

Note: Bit PEIE in the INTCON register must be set to enable any peripheral interrupt controlled by registers PIE1 through PIE6.

12.10.6 PIE4

Name: PIE4
Offset: 0x009A

Peripheral Interrupt Enable Register 4

Bit	7	6	5	4	3	2	1	0
	RC1IE	TX1IE	CLC4IE	CLC3IE	CLC2IE	CLC1IE	CWG1IE	NCO1IE
Access	R/W	R/W	R/W	R/W	R/W	R/W	R/W	R/W
Reset	0	0	0	0	0	0	0	0

Bit 7 – RC1IE EUSART1 Receive Interrupt Enable

Value	Description
1	EUSART1 receive interrupts are enabled
0	EUSART1 receive interrupts are disabled

Bit 6 – TX1IE EUSART1 Transmit Interrupt Enable

Value	Description
1	EUSART1 transmit interrupts are enabled
0	EUSART1 transmit interrupts are disabled

Bit 5 – CLC4IE CLC4 Interrupt Enable

Value	Description
1	CLC4 interrupts are enabled
0	CLC4 interrupts are disabled

Bit 4 – CLC3IE CLC3 Interrupt Enable

Value	Description
1	CLC3 interrupts are enabled
0	CLC3 interrupts are disabled

Bit 3 – CLC2IE CLC2 Interrupt Enable

Value	Description
1	CLC2 interrupts are enabled
0	CLC2 interrupts are disabled

Bit 2 – CLC1IE CLC1 Interrupt Enable

Value	Description
1	CLC1 interrupts are enabled
0	CLC1 interrupts are disabled

Bit 1 – CWG1IE CWG1 Interrupt Enable

Value	Description
1	CWG1 interrupts are enabled
0	CWG1 interrupts are disabled

Bit 0 – NCO1IE NCO1 Interrupt Enable

Value	Description
1	NCO1 interrupts are enabled
0	NCO1 interrupts are disabled

Note: Bit PEIE of the INTCON register must be set to enable any peripheral interrupt controlled by registers PIE1 through PIE6.

12.10.7 PIE5

Name: PIE5
Offset: 0x009B

Peripheral Interrupt Enable Register 5

Bit	7	6	5	4	3	2	1	0
	CM2IE	CM1IE	BCL2IE	SSP2IE	BCL1IE	SSP1IE	RC2IE	TX2IE
Access	R/W	R/W	R/W	R/W	R/W	R/W	R/W	R/W
Reset	0	0	0	0	0	0	0	0

Bit 7 – CM2IE Comparator 2 Interrupt Enable

Value	Description
1	Comparator 2 interrupts are enabled
0	Comparator 2 interrupts are disabled

Bit 6 – CM1IE Comparator 1 Interrupt Enable

Value	Description
1	Comparator 1 interrupts are enabled
0	Comparator 1 interrupts are disabled

Bit 5 – BCL2IE MSSP2 Bus Collision Interrupt Enable

Value	Description
1	MSSP2 Bus Collision interrupts are enabled
0	MSSP2 Bus Collision interrupts are disabled

Bit 4 – SSP2IE MSSP2 Interrupt Enable

Value	Description
1	MSSP2 interrupts are enabled
0	MSSP2 interrupts are disabled

Bit 3 – BCL1IE MSSP1 Bus Collision Interrupt Enable

Value	Description
1	MSSP1 Bus Collision interrupts are enabled
0	MSSP1 Bus Collision interrupts are disabled

Bit 2 – SSP1IE MSSP1 Interrupt Enable

Value	Description
1	MSSP1 interrupts are enabled
0	MSSP1 interrupts are disabled

Bit 1 – RC2IE EUSART2 Receive Interrupt Enable

Value	Description
1	EUSART2 receive interrupts are enabled
0	EUSART2 receive interrupts are disabled

Bit 0 – TX2IE EUSART2 Transmit Interrupt Enable

Value	Description
1	EUSART2 transmit interrupts are enabled
0	EUSART2 transmit interrupts are disabled

Note: Bit PEIE of the INTCON register must be set to enable any peripheral interrupt controlled by registers PIE1 through PIE6.

12.10.8 PIE6

Name: PIE6
Offset: 0x009C

Peripheral Interrupt Enable Register 6

Bit	7	6	5	4	3	2	1	0
						ZCDIE	ADTIE	ADIE
Access						R/W	R/W	R/W
Reset						0	0	0

Bit 2 – ZCDIE ZCD Interrupt Enable

Value	Description
1	ZCD interrupts are enabled
0	ZCD interrupts are disabled

Bit 1 – ADTIE ADC Threshold Interrupt Enable

Value	Description
1	ADC Threshold interrupts are enabled
0	ADC Threshold interrupts are disabled

Bit 0 – ADIE ADC Interrupt Enable

Value	Description
1	ADC interrupts are enabled
0	ADC interrupts are disabled

Note: Bit PEIE of the INTCON register must be set to enable any peripheral interrupt controlled by registers PIE1 through PIE6.

12.10.9 PIR0

Name: PIR0
Offset: 0x008C

Peripheral Interrupt Request Register 0

Bit	7	6	5	4	3	2	1	0
			TMR0IF	IOCIF				INTF
Access			R/W/HS	R				R/W/HS
Reset			0	0				0

Bit 5 – TMR0IF Timer0 Interrupt Flag

Value	Description
1	TMR0 register has overflowed (must be cleared by software)
0	TMR0 register has not overflowed

Bit 4 – IOCIF Interrupt-on-Change Flag⁽²⁾

Value	Description
1	One or more of the IOCAF-IOCCF register bits are currently set, indicating an enabled edge was detected by the IOC module.
0	None of the IOCAF-IOCCF register bits are currently set

Bit 0 – INTF External Interrupt Flag⁽¹⁾

Value	Description
1	External Interrupt has occurred
0	External Interrupt has not occurred

Notes:

1. The External Interrupt INT pin is selected by INTPPS.
2. The IOCIF bit is the logical OR of all the IOCAF-IOCCF flags. Therefore, to clear the IOCIF flag, application firmware must clear all of the lower level IOCAF-IOCCF register bits.
3. Interrupt flag bits are set when an Interrupt condition occurs, regardless of the state of its corresponding enable bit or the Global Enable (GIE) bit. User software may ensure the appropriate interrupt flag bits are cleared before enabling an interrupt.

12.10.10 PIR1

Name: PIR1
Offset: 0x008D

Peripheral Interrupt Request Register 1

Bit	7	6	5	4	3	2	1	0
	TMR1GIF	TMR1IF	OSFIF	CSWIF	ACTIF	SCANIF	CRCIF	NVMIF
Access	R/W/HS	R/W/HS	R	R	R/W/HS	R/W/HS	R/W/HS	R/W/HS
Reset	0	0	0	0	0	0	0	0

Bit 7 – TMR1GIF TMR1 Gate Interrupt Flag

Value	Description
1	The TMR1 Gate has gone inactive (must be cleared in software)
0	TMR1 Gate is active

Bit 6 – TMR1IF TMR1 Interrupt Flag

Value	Description
1	TMR1 interrupt has occurred (must be cleared in software)
0	TMR1 interrupt event has not occurred

Bit 5 – OSFIF Oscillator Failure Interrupt Flag

Value	Description
1	An oscillator failure event has been detected (must be cleared in software)
0	An oscillator failure event has not been detected

Bit 4 – CSWIF Clock Switch Interrupt Flag

Value	Description
1	A Clock Switch interrupt has occurred (must be cleared in software)
0	A Clock Switch interrupt event has not occurred

Bit 3 – ACTIF Active Clock Tuning Interrupt Flag

Value	Description
1	Active Clock Tuning interrupt occurred (must be cleared in software)
0	Active Clock Tuning interrupt event has not occurred

Bit 2 – SCANIF Memory Scanner Interrupt Flag

Value	Description
1	Memory Scanner interrupt has occurred (must be cleared in software)
0	Memory Scanner interrupt event has not occurred

Bit 1 – CRCIF CRC Interrupt Flag

Value	Description
1	CRC interrupt has occurred (must be cleared in software)
0	CRC interrupt event has not occurred

Bit 0 – NVMIF Nonvolatile Memory (NVM) Interrupt Flag

Value	Description
1	The requested NVM operation has completed (must be cleared in software)
0	NVM interrupt event has not occurred

Note: Interrupt flag bits are set when an Interrupt condition occurs, regardless of the state of its corresponding enable bit or the Global Enable (GIE) bit. User software may ensure the appropriate interrupt flag bits are cleared before enabling an interrupt.

12.10.11 PIR2

Name: PIR2
Offset: 0x008E

Peripheral Interrupt Request Register 2

Bit	7	6	5	4	3	2	1	0
		CCP2IF	CCP1IF		TMR4IF	TMR2IF	TMR3GIF	TMR3IF
Access		R/W/HS	R/W/HS		R/W/HS	R/W/HS	R/W/HS	R/W/HS
Reset		0	0		0	0	0	0

Bit 6 – CCP2IF CCP2 Interrupt Flag

Value	CCP Mode		
	Capture	Compare	PWM
1	Capture occurred (must be cleared in software)	Compare match occurred (must be cleared in software)	Output trailing edge occurred (must be cleared in software)
0	Capture did not occur	Compare match did not occur	Output trailing edge did not occur

Bit 5 – CCP1IF CCP1 Interrupt Flag

Value	CCP Mode		
	Capture	Compare	PWM
1	Capture occurred (must be cleared in software)	Compare match occurred (must be cleared in software)	Output trailing edge occurred (must be cleared in software)
0	Capture did not occur	Compare match did not occur	Output trailing edge did not occur

Bit 3 – TMR4IF TMR4 Interrupt Flag

Value	Description
1	TMR4 interrupt has occurred (must be cleared in software)
0	TMR4 interrupt event has not occurred

Bit 2 – TMR2IF TMR2 Interrupt Flag

Value	Description
1	TMR2 interrupt has occurred (must be cleared in software)
0	TMR2 interrupt event has not occurred

Bit 1 – TMR3GIF TMR3 Gate Interrupt Flag

Value	Description
1	The TMR3 Gate has gone inactive (must be cleared in software)
0	TMR3 Gate is active

Bit 0 – TMR3IF TMR3 Interrupt Flag

Value	Description
1	TMR3 interrupt has occurred (must be cleared in software)
0	TMR3 interrupt event has not occurred

Note: Interrupt flag bits are set when an Interrupt condition occurs, regardless of the state of its corresponding enable bit or the Global Enable (GIE) bit. User software may ensure the appropriate interrupt flag bits are cleared before enabling an interrupt.

12.10.12 PIR3

Name: PIR3
Offset: 0x008F

Peripheral Interrupt Request Register 3

Bit	7	6	5	4	3	2	1	0
					PWM2IF	PWM2PIF	PWM1IF	PWM1PIF
Access					R/W/HS	R/W/HS	R/W/HS	R/W/HS
Reset					0	0	0	0

Bit 3 – PWM2IF PWM2 Parameter Interrupt Flag

Value	Description
1	PWM2 Parameter interrupt has occurred (must be cleared in software)
0	PWM2 Parameter interrupt event has not occurred

Bit 2 – PWM2PIF PWM2 Period Interrupt Flag

Value	Description
1	PWM2 Period interrupt has occurred (must be cleared in software)
0	PWM2 Period interrupt event has not occurred

Bit 1 – PWM1IF PWM1 Parameter Interrupt Flag

Value	Description
1	PWM1 Parameter interrupt has occurred (must be cleared in software)
0	PWM1 Parameter interrupt event has not occurred

Bit 0 – PWM1PIF PWM1 Period Interrupt Flag

Value	Description
1	PWM1 Period interrupt has occurred (must be cleared in software)
0	PWM1 Period interrupt event has not occurred

Note: Interrupt flag bits are set when an Interrupt condition occurs, regardless of the state of its corresponding enable bit or the Global Enable (GIE) bit. User software may ensure the appropriate interrupt flag bits are cleared before enabling an interrupt.

12.10.13 PIR4

Name: PIR4
Offset: 0x0090

Peripheral Interrupt Request Register 4

Bit	7	6	5	4	3	2	1	0
	RC1IF	TX1IF	CLC4IF	CLC3IF	CLC2IF	CLC1IF	CWG1IF	NCO1IF
Access	R	R	R/W/HS	R/W/HS	R/W/HS	R/W/HS	R/W/HS	R/W/HS
Reset	0	0	0	0	0	0	0	0

Bit 7 – RC1IF EUSART1 Receive Interrupt Flag⁽¹⁾

Value	Description
1	The EUSART1 receive buffer (RC1REG) is not empty (contains at least one byte)
0	The EUSART1 receive buffer is empty

Bit 6 – TX1IF EUSART1 Transmit Interrupt Flag⁽²⁾

Value	Description
1	The EUSART1 transmit buffer (TX1REG) is empty
0	The EUSART1 transmit buffer is not empty

Bit 5 – CLC4IF CLC4 Interrupt Flag

Value	Description
1	CLC4 interrupt has occurred (must be cleared in software)
0	CLC4 interrupt event has not occurred

Bit 4 – CLC3IF CLC3 Interrupt Flag

Value	Description
1	CLC3 interrupt has occurred (must be cleared in software)
0	CLC3 interrupt event has not occurred

Bit 3 – CLC2IF CLC2 Interrupt Flag

Value	Description
1	CLC2 interrupt has occurred (must be cleared in software)
0	CLC2 interrupt event has not occurred

Bit 2 – CLC1IF CLC1 Interrupt Flag

Value	Description
1	CLC1 interrupt has occurred (must be cleared in software)
0	CLC1 interrupt event has not occurred

Bit 1 – CWG1IF CWG1 Interrupt Flag

Value	Description
1	CWG1 interrupt has occurred (must be cleared in software)
0	CWG1 interrupt event has not occurred

Bit 0 – NCO1IF NCO1 Interrupt Flag

Value	Description
1	NCO1 interrupt has occurred (must be cleared in software)
0	NCO1 interrupt event has not occurred

Notes:

1. RC1IF is read-only. User software must read RC1REG to clear RC1IF.
2. TX1IF is read-only. User software must load TX1REG to clear TX1IF. TX1IF does not indicate a completed transmission (use TMRT for this purpose instead).
3. Interrupt flag bits are set when an Interrupt condition occurs, regardless of the state of its corresponding enable bit or the Global Enable (GIE) bit. User software may ensure the appropriate interrupt flag bits are cleared before enabling an interrupt.

12.10.14 PIR5

Name: PIR5
Offset: 0x0091

Peripheral Interrupt Request Register 5

Bit	7	6	5	4	3	2	1	0
	CM2IF	CM1IF	BCL2IF	SSP2IF	BCL1IF	SSP1IF	RC2IF	TX2IF
Access	R/W/HS	R/W/HS	R/W/HS	R/W/HS	R/W/HS	R/W/HS	R	R
Reset	0	0	0	0	0	0	0	0

Bit 7 – CM2IF Comparator 2 Interrupt Flag

Value	Description
1	Comparator 2 interrupt has occurred (must be cleared in software)
0	Comparator 2 interrupt event has not occurred

Bit 6 – CM1IF Comparator 1 Interrupt Flag

Value	Description
1	Comparator 2 interrupt has occurred (must be cleared in software)
0	Comparator 2 interrupt event has not occurred

Bit 5 – BCL2IF MSSP2 Bus Collision Interrupt Flag

Value	Description
1	An MSSP2 Bus Collision interrupt has occurred (must be cleared in software)
0	No MSSP2 Bus Collision event was detected

Bit 4 – SSP2IF MSSP2 Interrupt Flag

Value	Description
1	MSSP 2 interrupt has occurred (must be cleared in software)
0	MSSP2 interrupt event has not occurred

Bit 3 – BCL1IF MSSP1 Bus Collision Interrupt Flag

Value	Description
1	An MSSP1 Bus Collision was detected (must be cleared in software)
0	No MSSP1 Bus Collision event was detected

Bit 2 – SSP1IF MSSP1 Interrupt Flag

Value	Description
1	MSSP1 interrupt has occurred (must be cleared in software)
0	MSSP1 interrupt event has not occurred

Bit 1 – RC2IF EUSART2 Receive Interrupt Flag⁽¹⁾

Value	Description
1	The EUSART2 receive buffer (RC2REG) is not empty (contains at least one byte)
0	The EUSART2 receive buffer is empty

Bit 0 – TX2IF EUSART2 Transmit Interrupt Flag⁽²⁾

Value	Description
1	The EUSART2 transmit buffer (TX2REG) is empty
0	The EUSART2 transmit buffer is not empty

Notes:

1. RC2IF is read-only. User software must read RC2REG to clear RC2IF.
2. TX2IF is read-only. User software must load TX2REG to clear TX2IF. TX2IF does not indicate a completed transmission (use TMRT for this purpose instead).
3. Interrupt flag bits are set when an Interrupt condition occurs, regardless of the state of its corresponding enable bit or the Global Enable (GIE) bit. User software may ensure the appropriate interrupt flag bits are cleared before enabling an interrupt.

12.10.15 PIR6

Name: PIR6
Offset: 0x0092

Peripheral Interrupt Request Register 6

Bit	7	6	5	4	3	2	1	0
						ZCDIF	ADTIF	ADIF
Access						R/W/HS	R/W/HS	R/W/HS
Reset						0	0	0

Bit 2 - ZCDIF Zero-Cross Detect (ZCD) Interrupt Flag

Value	Description
1	A ZCD interrupt occurred (must be cleared in software)
0	A ZCD interrupt has not occurred

Bit 1 - ADTIF ADC Threshold Interrupt Flag

Value	Description
1	ADC Threshold interrupt has occurred (must be cleared in software)
0	ADC Threshold interrupt event has not occurred

Bit 0 - ADIF ADC Interrupt Flag

Value	Description
1	ADC interrupt has occurred (must be cleared in software)
0	ADC interrupt event has not occurred

Note: Interrupt flag bits are set when an Interrupt condition occurs, regardless of the state of its corresponding enable bit or the Global Enable (GIE) bit. User software may ensure the appropriate interrupt flag bits are cleared before enabling an interrupt.

12.11 Register Summary - Interrupt Control

Offset	Name	Bit Pos.	7	6	5	4	3	2	1	0
0x00	Reserved									
...										
0x0A										
0x0B	INTCON	7:0	GIE	PEIE						INTEDG
0x0C	Reserved									
...										
0x8B										
0x8C	PIR0	7:0			TMR0IF	IOCIF				INTF
0x8D	PIR1	7:0	TMR1GIF	TMR1IF	OSFIF	CSWIF	ACTIF	SCANIF	CRCIF	NVMIF
0x8E	PIR2	7:0		CCP2IF	CCP1IF		TMR4IF	TMR2IF	TMR3GIF	TMR3IF
0x8F	PIR3	7:0					PWM2IF	PWM2PIF	PWM1IF	PWM1PIF
0x90	PIR4	7:0	RC1IF	TX1IF	CLC4IF	CLC3IF	CLC2IF	CLC1IF	CWG1IF	NCO1IF
0x91	PIR5	7:0	CM2IF	CM1IF	BCL2IF	SSP2IF	BCL1IF	SSP1IF	RC2IF	TX2IF
0x92	PIR6	7:0						ZCDIF	ADTIF	ADIF
0x93	Reserved									
...										
0x95										
0x96	PIE0	7:0			TMR0IE	IOIE				INTE
0x97	PIE1	7:0	TMR1GIE	TMR1IE	OSFIE	CSWIE	ACTIE	SCANIE	CRCIE	NVMIE
0x98	PIE2	7:0		CCP2IE	CCP1IE		TMR4IE	TMR2IE	TMR3GIE	TMR3IE
0x99	PIE3	7:0					PWM2IE	PWM2PIE	PWM1IE	PWM1PIE
0x9A	PIE4	7:0	RC1IE	TX1IE	CLC4IE	CLC3IE	CLC2IE	CLC1IE	CWG1IE	NCO1IE
0x9B	PIE5	7:0	CM2IE	CM1IE	BCL2IE	SSP2IE	BCL1IE	SSP1IE	RC2IE	TX2IE
0x9C	PIE6	7:0						ZCDIE	ADTIE	ADIE

13. Power-Saving Modes

The purpose of the Power-Saving modes is to reduce power consumption. There are three Power-Saving modes:

- Doze mode
- Sleep mode
- Idle mode

13.1 Doze Mode

Doze mode allows for power saving by reducing CPU operation and Program Flash Memory (PFM) access, without affecting peripheral operation. Doze mode differs from Sleep mode because the band gap and system oscillators continue to operate, while only the CPU and PFM are affected. The reduced execution saves power by eliminating unnecessary operations within the CPU and memory.

When the Doze Enable bit is set (**DOZEN** = 'b1) the CPU executes only one instruction cycle out of every N cycles as defined by the **DOZE** bits. For example, if **DOZE** = 001, the instruction cycle ratio is 1:4. The CPU and memory execute for one instruction cycle and then lay Idle for three instruction cycles. During the unused cycles, the peripherals continue to operate at the system clock speed.

13.1.1 Doze Operation

The Doze operation is illustrated in [Figure 13-1](#). As with normal operation, the instruction is fetched for the next instruction cycle while the previous instruction is executed. The Q-clocks to the peripherals continue throughout the periods in which no instructions are fetched or executed. The following configuration settings apply for this example:

- Doze enabled (**DOZEN** = 1)
- CPU instruction cycle to peripheral instruction cycle ratio of 1:4
- Recover-on-Interrupt enabled (**ROI** = 1)

Figure 13-1. Doze Mode Operation Example

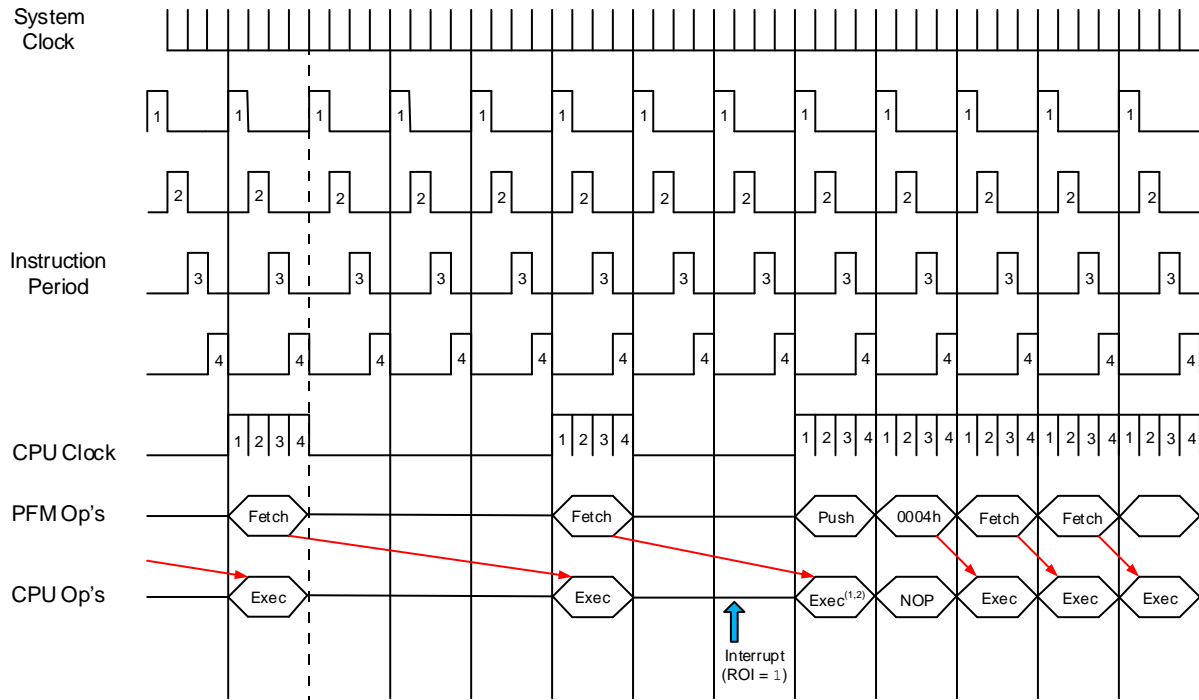

Notes:

1. Multicycle instructions are executed to completion before fetching 0x0004.
2. If the prefetched instruction clears GIE, the ISR will not occur, but DOZEN is still cleared and the CPU will resume execution at full speed.

13.1.2 Interrupts During Doze

System behavior for interrupts that may occur during Doze mode are configured using the ROI and DOE bits. Refer to the example below for details about system behavior in all cases for a transition from Main to ISR back to Main.

Example 13-1. Doze Software Example

```

// Mainline operation
bool somethingToDo = FALSE;

void main() {
    initializeSystem();
    // DOZE = 64:1 (for example)
    // ROI = 1;
    GIE = 1; // enable interrupts
    while (1) {
        // If ADC completed, process data
        if (somethingToDo) {
            doSomething();
            DOZEN = 1; // resume low power
        }
    }
}

// Data interrupt handler

void interrupt() {
    // DOZEN = 0 because ROI = 1
    if (ADIF) {
        somethingToDo = TRUE;
        DOE = 0; // make main() go fast
        ADIF = 0;
    }
}

```

```

    }
    // else check other interrupts...
    if (TMR0IF) {
        timerTick++;
        DOE = 1; // make main() go slow
        TMR0IF = 0;
    }
}

```

Note: User software can change the DOE bit in the ISR.

13.2 Sleep Mode

Sleep mode provides the greatest power savings because both the CPU and selected peripherals cease to operate. However, some peripheral clocks continue to operate during Sleep. The peripherals that use those clocks also continue to operate. Sleep mode is entered by executing the `SLEEP` instruction, while the `IDLEN` bit is clear. Upon entering Sleep mode, the following conditions exist:

1. The WDT will be cleared, but keeps running if enabled for operation during Sleep.
2. The \overline{PD} bit of the STATUS register is cleared.
3. The \overline{TO} bit of the STATUS register is set.
4. The CPU clock is disabled.
5. LFINTOSC, SOSC, HFINTOSC and ADCRC are unaffected. Peripherals using them may continue operation during Sleep.
6. I/O ports maintain the status they had before Sleep was executed (driving high, low, or high-impedance).
7. Resets other than WDT are not affected by Sleep mode.



Important: Refer to individual chapters for more details on peripheral operation during Sleep.

To minimize current consumption, consider the following conditions:

- I/O pins must not be floating
- External circuitry sinking current from I/O pins
- Internal circuitry sourcing current to I/O pins
- Current draw from pins with internal weak pull-ups
- Peripherals using clock source unaffected by Sleep

I/O pins that are high-impedance inputs need to be pulled to V_{DD} or V_{SS} externally to avoid switching currents caused by floating inputs. Examples of internal circuitry that might be consuming current include modules such as the DAC and FVR peripherals.

13.2.1 Wake-Up from Sleep

The device can wake up from Sleep through one of the following events:

1. External Reset input on \overline{MCLR} pin, if enabled.
2. BOR Reset, if enabled.
3. Low-Power Brown-out Reset (LPBOR), if enabled.
4. POR Reset.

5. Windowed Watchdog Timer, if enabled.
6. All interrupt sources except clock switch interrupt can wake up the part.



Important: The first five events will cause a device Reset. The last event in the list is considered a continuation of program execution. For more information about determining whether a device Reset or wake-up event occurred, refer to the **“Resets”** chapter.

When the `SLEEP` instruction is being executed, the next instruction (PC + 2) is prefetched. For the device to wake up through an interrupt event, the corresponding Interrupt Enable bit must be enabled in the P_{IE}x register. Wake-up will occur regardless of the state of the Global Interrupt Enable (GIE) bit. If the GIE bit is disabled, the device will continue execution at the instruction after the `SLEEP` instruction. If the GIE bit is enabled, the device executes the instruction after the `SLEEP` instruction and then call the Interrupt Service Routine (ISR).



Important: It is recommended to add a `NOP` as the immediate instruction after the `SLEEP` instruction.

The WDT is cleared when the device wakes up from Sleep, regardless of the source of wake-up. Upon a wake-from-Sleep event, the core will wait for a combination of three conditions before beginning execution. The conditions are:

- PFM Ready
- System Clock Ready
- BOR Ready (unless BOR is disabled)

13.2.2 Wake-Up Using Interrupts

When global interrupts are disabled (GIE cleared) and any interrupt source, with the exception of the clock switch interrupt, has both its interrupt enable bit and interrupt flag bit set, one of the following will occur:

- If the interrupt occurs before the execution of a `SLEEP` instruction
 - The `SLEEP` instruction will execute as a `NOP`
 - The WDT and WDT prescaler will not be cleared
 - The \overline{TO} bit of the STATUS register will not be set
 - The \overline{PD} bit of the STATUS register will not be cleared
- If the interrupt occurs during or after the execution of a `SLEEP` instruction
 - The `SLEEP` instruction will be completely executed
 - The device will immediately wake up from Sleep
 - The WDT and WDT prescaler will be cleared
 - The \overline{TO} bit of the STATUS register will be set
 - The \overline{PD} bit of the STATUS register will be cleared

In the event where flag bits were checked before executing a `SLEEP` instruction, it may be possible for flag bits to have become set before the `SLEEP` instruction completes. To determine whether a `SLEEP` instruction executed, test the \overline{PD} bit. If the \overline{PD} bit is set, the `SLEEP` instruction was executed as a `NOP`.

Figure 13-2. Wake-Up from Sleep through Interrupt

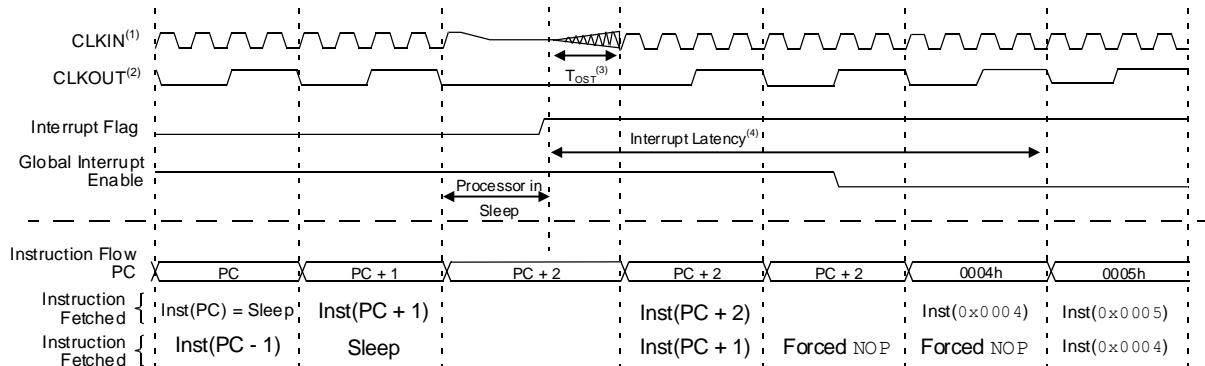

Notes:

1. External clock - High, Low mode assumed.
2. CLKOUT is shown here for timing reference.
3. $T_{OST} = 1024 T_{OSC}$. This delay does not apply to EC and INTOSC Oscillator modes.
4. $GIE = 1$ assumed. In this case after wake-up, the processor calls the ISR at 0x0004. If $GIE = 0$, execution will continue in-line.

13.3 Idle Mode

When the **IDLEN** bit is clear, the **SLEEP** instruction will put the device into full Sleep mode. When **IDLEN** is set, the **SLEEP** instruction will put the device into Idle mode. In Idle mode, the CPU and memory operations are halted, but the peripheral clocks continue to run. This mode is similar to Doze mode, except that in Idle both the CPU and program memory are shut off.



Important:

1. Peripherals using F_{OSC} will continue to operate while in Idle (but not in Sleep). Peripherals using $HFINTOSC:LFINTOSC$ will continue running in both Idle and Sleep.
2. When the Clock Out Enable (**CLKOUTEN**) Configuration bit is cleared, the CLKOUT pin will continue operating while in Idle.

13.3.1 Idle and Interrupts

Idle mode ends when an interrupt occurs (even if global interrupts are disabled), but **IDLEN** is not changed. The device can re-enter Idle by executing the **SLEEP** instruction. If Recover-on-Interrupt is enabled ($ROI = 1$), the interrupt that brings the device out of Idle also restores full-speed CPU execution when Doze is also enabled.

13.3.2 Idle and WWDT

When in Idle, the WWDT Reset is blocked and will instead wake the device. The WWDT wake-up is not an interrupt, therefore **ROI** does not apply.



Important: The WWDT can bring the device out of Idle, in the same way it brings the device out of Sleep. The **DOZEN** bit is not affected.

13.4 Peripheral Operation in Power-Saving Modes

All selected clock sources and the peripherals running from them are active in both Idle and Doze modes. Only in Sleep mode, both the F_{OSC} and $F_{OSC}/4$ clocks are unavailable. However, all other clock sources enabled specifically or through peripheral clock selection before the part enters Sleep, remain operating in Sleep.

13.5 Register Definitions: Power-Savings Control

13.5.1 CPUDOZE

Name: CPUDOZE
Offset: 0x028C

Doze and Idle Register

Bit	7	6	5	4	3	2	1	0
	IDLEN	DOZEN	ROI	DOE		DOZE[2:0]		
Access	R/W	R/W/HC/HS	R/W	R/W/HC/HS		R/W	R/W	R/W
Reset	0	0	0	0		0	0	0

Bit 7 – IDLEN Idle Enable

Value	Description
1	A SLEEP instruction places device into Idle mode
0	A SLEEP instruction places the device into Sleep mode

Bit 6 – DOZEN Doze Enable⁽¹⁾

Value	Description
1	Places devices into Doze setting
0	Places devices into Normal mode

Bit 5 – ROI Recover-on-Interrupt⁽¹⁾

Value	Description
1	Entering the Interrupt Service Routine (ISR) makes DOZEN = 0
0	Entering the Interrupt Service Routine (ISR) does not change DOZEN

Bit 4 – DOE Doze-on-Exit⁽¹⁾

Value	Description
1	Exiting the ISR makes DOZEN = 1
0	Exiting the ISR does not change DOZEN

Bits 2:0 – DOZE[2:0] Ratio of CPU Instruction Cycles to Peripheral Instruction Cycles

Value	Description
111	1:256
110	1:128
101	1:64
100	1:32
011	1:16
010	1:8
001	1:4
000	1:2

Note:

1. When ROI = 1 or DOE = 1.

13.6 Register Summary - Power-Savings Control

Offset	Name	Bit Pos.	7	6	5	4	3	2	1	0
0x00	Reserved									
...										
0x028B										
0x028C	CPUDOZE	7:0	IDLEN	DOZEN	ROI	DOE			DOZE[2:0]	

14. WWDT - Windowed Watchdog Timer

A Watchdog Timer (WDT) is a system timer that generates a Reset if the firmware does not issue a `CLRWDT` instruction within the time-out period. A Watchdog Timer is typically used to recover the system from unexpected events. The Windowed Watchdog Timer (WWDT) differs from nonwindowed operation in that `CLRWDT` instructions are only accepted when they are performed within a specific window during the time-out period.

The WWDT has the following features:

- Selectable clock source
- Multiple operating modes
 - WWDT is always on
 - WWDT is off when in Sleep
 - WWDT is controlled by software
 - WWDT is always off
- Configurable time-out period from 1 ms to 256s (nominal)
- Configurable window size from 12.5% to 100% of the time-out period
- Multiple Reset conditions

Figure 14-1. Windowed Watchdog Timer Block Diagram

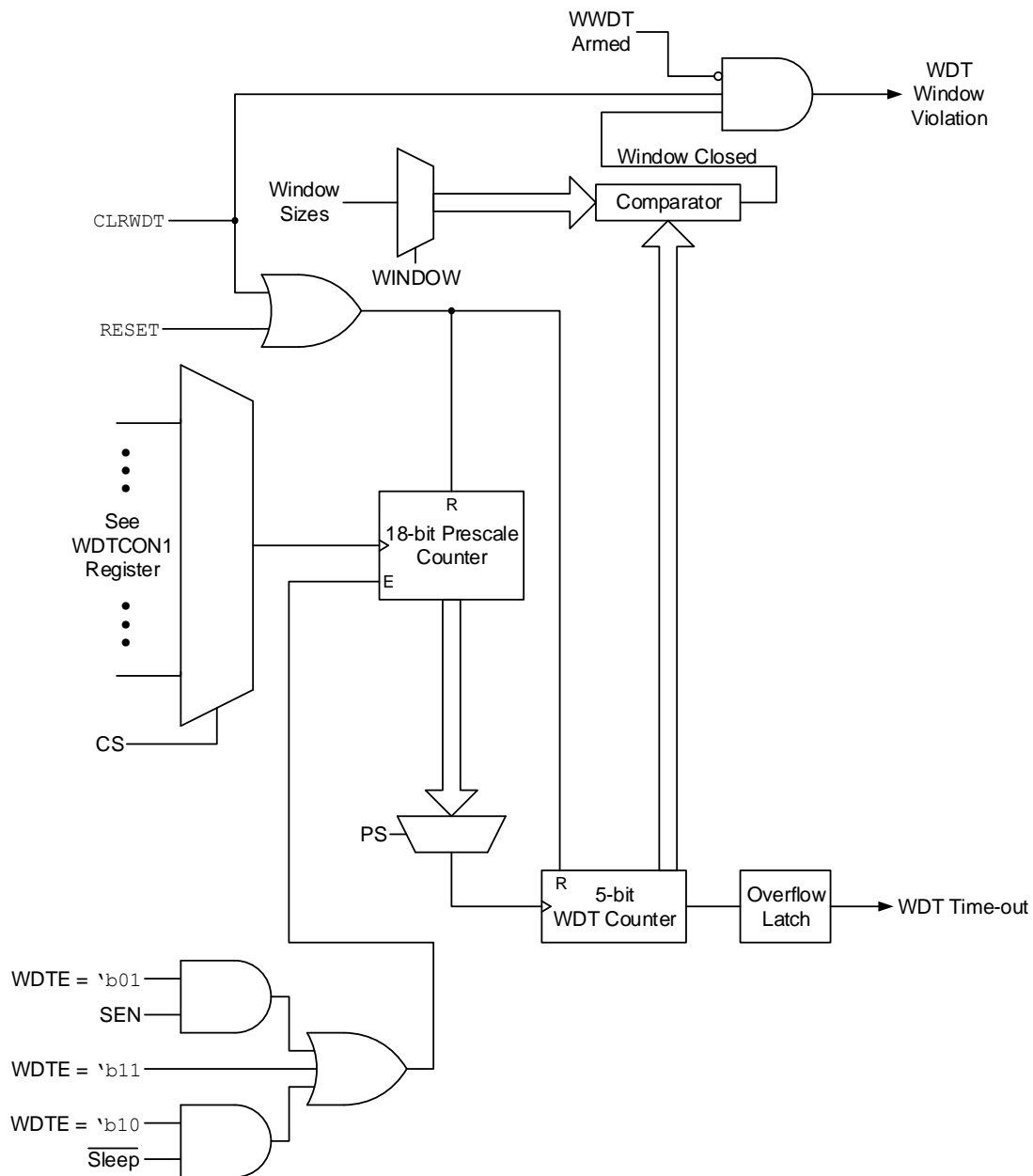

14.1 Independent Clock Source

The WWDT can derive its time base from either the 31 KHz LFINTOSC or 31.25 kHz MFINTOSC internal oscillators, depending on the value of WDT Operating Mode (WDTE) Configuration bits. If $WDTE = \text{'b1}x$, then the clock source will be enabled depending on the WDTCCS Configuration bits. If $WDTE = \text{'b01}$, the **SEN** bit will be set by software to enable WWDT and the clock source is enabled by the **CS** bits. Time intervals in this chapter are based on a minimum nominal interval of 1 ms. See the device Electrical Specifications for LFINTOSC and MFINTOSC tolerances.

14.2 WWDT Operating Modes

The Windowed Watchdog Timer module has four operating modes that are controlled by the WDTE Configuration bit. The table below summarizes the different WWDT operating modes.

Table 14-1. WWDT Operating Modes

WDTE	SEN	Device Mode	WWDT Mode
11	X	X	Active
10	X	Awake	Active
		Sleep	Disabled
01	1	X	Active
	0	X	Disabled
00	X	X	Disabled

14.2.1 WWDT Is Always On

When the WDTE Configuration bits are set to `'b11`, the WWDT is always on. WWDT protection is active during Sleep.

14.2.2 WWDT Is Off in Sleep

When the WDTE Configuration bits are set to `'b10`, the WWDT is on, except in Sleep mode. WWDT protection is not active during Sleep.

14.2.3 WWDT Controlled by Software

When the WDTE Configuration bits are set to `'b01`, the WWDT is controlled by the SEN bit. WWDT protection is unchanged by Sleep. See [Table 14-1](#) for more details.

14.3 Time-Out Period

When the WDTCP5 Configuration bits are set to the default value of `'b11111`, the PS bits set the time-out period from 1 ms to 256 seconds (nominal). If any value other than the default value is assigned to the WDTCP5 Configuration bits, then the timer period will be based on the WDTCP5 Configuration bits. After a Reset, the default time-out period is 2s.

14.4 Watchdog Window

The Windowed Watchdog Timer has an optional Windowed mode that is controlled by either the WDTCP5 Configuration bits or the WINDOW bits. In the Windowed mode (`WINDOW < 'b1111`), the CLRWDT instruction must occur within the allowed window of the WDT period. Any CLRWDT instruction that occurs outside of this window will trigger a window violation and will cause a WWDT Reset, similar to a WWDT time-out. See [Figure 14-2](#) for an example.

When the WDTCP5 Configuration bits are `'b111`, then the window size is controlled by the WINDOW bits, otherwise the window size is controlled by the WDTCP5 bits. The five Most Significant bits of the WDTTMR register are used to determine whether the window is open, as defined by the window size. In the event of a window violation, a Reset will be generated and the WDTWV bit of the PCON0 register will be cleared. This bit is set by a POR and can be set by software.

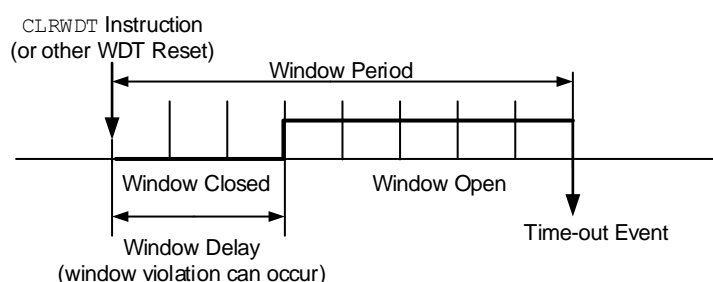
Figure 14-2. Window Period and Delay

14.5 Clearing the Watchdog Timer

The Watchdog Timer is cleared when any of the following conditions occur:

- Any Reset
- A valid CLRWDT instruction is executed
- The device enters Sleep
- The device exits Sleep by Interrupt
- The WWDT is disabled
- The Oscillator Start-up Timer (OST) is running
- Any write to the WDTCON0 or WDTCON1 registers

14.5.1 CLRWDT Considerations (Windowed Mode)

When in Windowed mode, the WWDT must be armed before a CLRWDT instruction will clear the timer. This is performed by reading the WDTCON0 register. Executing a CLRWDT instruction without performing such an arming action will trigger a window violation regardless of whether the window is open or not. See [Table 14-2](#) for more information.

14.6 Operation During Sleep

When the device enters Sleep, the Watchdog Timer is cleared. If the WWDT is enabled during Sleep, the Watchdog Timer resumes counting. When the device exits Sleep, the Watchdog Timer is cleared again. The Watchdog Timer remains clear until the Oscillator Start-up Timer (OST) completes, if enabled. When a WWDT time-out occurs while the device is in Sleep, no Reset is generated. Instead, the device wakes up and resumes operation. The TO and PD bits in the STATUS register are changed to indicate the event. The RWDT bit in the PCON0 register indicates that a Watchdog Reset has occurred.

Table 14-2. WWDT Clearing Conditions

Conditions	WWDT
WDTE = 'b00	Cleared
WDTE = 'b01 and SEN = 0	
WDTE = 'b10 and enter Sleep	
CLRWDT Command	
Oscillator Fail Detected	
Exit Sleep + System Clock = SOSC, EXTRC, INTOSC, EXTCLK	
Exit Sleep + System Clock = XT, HS, LP	Cleared until the end of OST
Change INTOSC divider (NOSC bits)	Unaffected

14.7 Register Definitions: Windowed Watchdog Timer Control

Long bit name prefixes for the Windowed Watchdog Timer peripherals are shown in the following table. Refer to the "Long Bit Names" section in the "Register and Bit Naming Conventions" chapter for more information.

Table 14-3. WWDT Long Bit Name Prefixes

Peripheral	Bit Name Prefix
WDT	WDT

14.7.1 WDTCON0

Name: WDTCON0

Offset: 0x018C

Watchdog Timer Control Register 0

Bit	7	6	5	4	3	2	1	0
			PS[4:0]					SEN
Access			R/W	R/W	R/W	R/W	R/W	R/W
Reset			q	q	q	q	q	0

Bits 5:1 – PS[4:0] Watchdog Timer Prescaler Select⁽²⁾

Value	Description
11111 to 10011	Reserved. Results in minimum interval (1 ms)
10010	1:8388608 (2 ²³) (Interval 256s nominal)
10001	1:4194304 (2 ²²) (Interval 128s nominal)
10000	1:2097152 (2 ²¹) (Interval 64s nominal)
01111	1:1048576 (2 ²⁰) (Interval 32s nominal)
01110	1:524288 (2 ¹⁹) (Interval 16s nominal)
01101	1:262144 (2 ¹⁸) (Interval 8s nominal)
01100	1:131072 (2 ¹⁷) (Interval 4s nominal)
01011	1:65536 (Interval 2s nominal) (Reset value)
01010	1:32768 (Interval 1s nominal)
01001	1:16384 (Interval 512 ms nominal)
01000	1:8192 (Interval 256 ms nominal)
00111	1:4096 (Interval 128 ms nominal)
00110	1:2048 (Interval 64 ms nominal)
00101	1:1024 (Interval 32 ms nominal)
00100	1:512 (Interval 16 ms nominal)
00011	1:256 (Interval 8 ms nominal)
00010	1:128 (Interval 4 ms nominal)
00001	1:64 (Interval 2 ms nominal)
00000	1:32 (Interval 1 ms nominal)

Bit 0 – SEN Software Enable/Disable for Watchdog Timer

Value	Condition	Description
x	If WDTE = 1x	This bit is ignored
1	If WDTE = 01	WDT is turned on
0	If WDTE = 01	WDT is turned off
x	If WDTE = 00	This bit is ignored

Notes:

- When the WDTCP Configuration bits = 'b11111, the Reset value (q) of WDTPS is 'b01011. Otherwise, the Reset value of WDTPS is equal to the WDTCP Configuration bits.
- When the WDTCP Configuration bits ≠ 'b11111, these bits are read-only.

14.7.2 WDTCON1

Name: WDTCON1

Offset: 0x018D

Watchdog Timer Control Register 1

Bit	7	6	5	4	3	2	1	0
		CS[2:0]				WINDOW[2:0]		
Access		R/W	R/W	R/W		R/W	R/W	R/W
Reset		q	q	q		q	q	q

Bits 6:4 – CS[2:0] Watchdog Timer Clock Select^(1,3)

CS	Clock Source
111-100	Reserved
011	EXTOSC
010	SOSC
001	MFINTOSC (32 kHz)
000	LFINTOSC (31 kHz)

Bits 2:0 – WINDOW[2:0] Watchdog Timer Window Select^(2,4)

WINDOW	Window Delay Percent of Time	Window Opening Percent of Time
111	N/A	100
110	12.5	87.5
101	25	75
100	37.5	62.5
011	50	50
010	62.5	37.5
001	75	25
000	87.5	12.5

Notes:

1. When the WDTCCS in Configuration bits = '0b111 , the Reset value of WDTCS is 'b000 .
2. The Reset value (q) of WINDOW is determined by the value of WDTCS in the Configuration bits.
3. When the WDTCCS in Configuration bits $\neq \text{'b111}$, these bits are read-only.
4. When the WDTCS in Configuration bits $\neq \text{'b111}$, these bits are read-only.

14.7.3 WDTPSH

Name: WDTPSH
Offset: 0x018F

WWDT Prescaler Select Register (Read-Only)

Bit	7	6	5	4	3	2	1	0
	PSCNTH[7:0]							
Access	R	R	R	R	R	R	R	R
Reset	0	0	0	0	0	0	0	0

Bits 7:0 – PSCNTH[7:0] Prescaler Select High Byte⁽¹⁾

Note:

1. The 18-bit WDT prescaler value, PSCNT[17:0] includes the WDTPSL, WDTPSH and the lower bits of the WDTTMR registers. PSCNT[17:0] is intended for debug operations and will be read during normal operation.

14.7.4 WDTPSL

Name: WDTPSL
Offset: 0x018E

WWDT Prescaler Select Register (Read-Only)

Bit	7	6	5	4	3	2	1	0
	PSCNTL[7:0]							
Access	R	R	R	R	R	R	R	R
Reset	0	0	0	0	0	0	0	0

Bits 7:0 – PSCNTL[7:0] Prescaler Select Low Byte⁽¹⁾

Note:

1. The 18-bit WDT prescaler value, PSCNT[17:0] includes the WDTPSL, WDTPSH and the lower bits of the WDTTMR registers. PSCNT[17:0] is intended for debug operations and will be read during normal operation.

14.7.5 WDTTMR

Name: WDTTMR
Offset: 0x0190

WDT Timer Register (Read-Only)

Bit	7	6	5	4	3	2	1	0
	TMR[4:0]					STATE	PSCNT[17:16]	
Access	R	R	R	R	R	R	R	R
Reset	0	0	0	0	0	0	0	0

Bits 7:3 – TMR[4:0] Watchdog Window Value

WINDOW	WDT Window State		Open Percent
	Closed	Open	
111	N/A	00000-11111	100
110	00000-00011	00100-11111	87.5
101	00000-00111	01000-11111	75
100	00000-01011	01100-11111	62.5
011	00000-01111	10000-11111	50
010	00000-10011	10100-11111	37.5
001	00000-10111	11000-11111	25
000	00000-11011	11100-11111	12.5

Bit 2 – STATE WDT Armed Status

Value	Description
1	WDT is armed
0	WDT is not armed

Bits 1:0 – PSCNT[17:16] Prescaler Select Upper Byte⁽¹⁾

Note:

- The 18-bit WDT prescaler value, PSCNT[17:0] includes the WDTPSL, WDTPSH and the lower bits of the WDTTMR registers. PSCNT[17:0] is intended for debug operations and will not be read during normal operation.

14.8 Register Summary - WDT Control

Offset	Name	Bit Pos.	7	6	5	4	3	2	1	0
0x00	Reserved									
...										
0x018B										
0x018C	WDTCON0	7:0					PS[4:0]			SEN
0x018D	WDTCON1	7:0			CS[2:0]				WINDOW[2:0]	
0x018E	WDTPSL	7:0					PSCNTL[7:0]			
0x018F	WDTPSH	7:0					PSCNTH[7:0]			
0x0190	WDTTMR	7:0			TMR[4:0]			STATE		PSCNT[17:16]

15. NVM - Nonvolatile Memory Control

The Nonvolatile Memory (NVM) module provides run-time read and write access to the Program Flash Memory (PFM), Data Flash Memory (DFM), and Configuration bits. PFM includes the program memory and user ID space. DFM is also referred to as EEPROM which is accessed one byte at a time and the erase before write is automatic.

NVM is accessible using both FSR and INDF registers or through the NVMREG register interface (see [Table 15-1](#)).

The write time is controlled by an on-chip timer. The write/erase voltages are generated by an on-chip charge pump rated to operate over the operating voltage range of the device.

PFM and DFM can be protected in two ways: code protection and write protection. Code protection (Configuration bits \overline{CP} (PFM)/ \overline{CPD} (DFM)) disables PFM/DFM read and write access through an external device programmer. Write protection prevents user software writes to NVM areas tagged for protection by the \overline{WRTn} Configuration bits. Code protection does not affect the self-write and erase functionality, whereas write protection does. Attempts to write a protected location will set the WRERR bit. Code protection and write protection can only be reset on a Bulk Erase performed by an external programmer.

The Bulk Erase command is used to completely erase program memory. The Bulk Erase command can only be issued through an external programmer. There is no run time access for this command.

If the device is code-protected and a Bulk Erase command for the configuration memory is issued; all other memory regions are also erased. Refer to the **“Family Programming Specification”** document for more details.

Table 15-1. NVM Organization and Access Information

Main Values			NVMREG Access			FSR Access	
Memory Function	Memory Type	Program Counter (PC), ICSP™ Address	NVMREGS bit (NVMCON1)	NVMADR[14:0]	Allowed Operations	FSR Address	FSR Programming Access
Reset Vector	Program Flash Memory	0x0000	0	0x0000	Read/Write	0x8000	Read-Only
User Memory		0x0001	0	0x0001		0x8001	
		0x0003	0	0x0003		0x8003	
INT Vector		0x0004	0	0x0004		0x8004	
User Memory		0x0005	0	0x0005		0x8005	
		0x3FFF ⁽¹⁾	0	0x3FFF ⁽¹⁾		0xFFFF	
User ID	Program Flash Memory	0x8000	1	0x0000	Read/Write	No Access	
		0x8003		0x0003			
Reserved	—	—	—	0x0004	—		
Revision ID	Hard Coded in Program Flash Memory	0x8005	1	0x0005	Read		
Device ID		0x8006	1	0x0006			
CONFIG1	Program Flash Memory	0x8007	1	0x0007	Read/Write		
CONFIG2		0x8008	1	0x0008			
CONFIG3		0x8009	1	0x0009			
CONFIG4		0x800A	1	0x000A			
CONFIG5		0x800B	1	0x000B			
DIA and DCI	Hard Coded in Program Flash Memory	0x8100	1	0x0100	Read		
		0x82FF	1	0x02FF			

.....continued

Main Values			NVMREG Access			FSR Access	
Memory Function	Memory Type	Program Counter (PC), ICSP™ Address	NVMREGS bit (NVMCON1)	NVMADR[14:0]	Allowed Operations	FSR Address	FSR Programming Access
EEPROM	Data Flash Memory	0xF000	1	0x7000	Read/Write	0x7000	Read
		0xF0FF		0x70FF		0x70FF	

Note:

1. The maximum Program Flash Memory address for the PIC16F181 family is 0x3FFF.

15.1 Program Flash Memory (PFM)

The Program Flash Memory (PFM) is readable, writable and erasable over the entire V_{DD} range.

PFM consists of the following regions:

- User program memory (read/write)
- Configuration Words (read/write)
- Device ID (read-only)
- Revision ID (read-only)
- User ID (read-write)
- Device Information Area (read-only)
- Device Configuration Information (read-only)

PFM can be read and/or written to through:

- CPU instruction fetch (read-only)
- FSR/INDF indirect access (read-only)
- NVMREG access (read-write)
- In-Circuit Serial Programming™ (ICSP™) (external read-write)

It is important to understand the program memory structure for erase and programming operations. Program memory is arranged in rows. A row consists of 32 14-bit program memory words. A row is the minimum size that can be erased by user software. A Bulk Erase command cannot be issued from user code.

Read operations return a single word of memory. Write and erase operations are done on a row basis. Program memory will erase to a logic '1' and program to a logic '0'.

All or a portion of a row can be programmed. Data to be written into the program memory row is written to 14-bit wide data write latches. These latches are not directly accessible, but may be loaded via sequential writes to the NVMDATH:NVMDATL register pair.



Important: To modify only a portion of a previously programmed row, the contents of the entire row must be read. Then, the new data and retained data can be written into the write latches to reprogram the row of program memory. However, any unprogrammed locations can be written without first erasing the row. In this case, it is not necessary to save and rewrite the other previously programmed locations.

Writing or erasing program memory will cease instruction fetches until the operation is complete. The program memory cannot be accessed during the write or erase, so code cannot execute. An internal programming timer controls the write time of program memory writes and erases.

A value written to program memory does not need to be a valid instruction. Executing a program memory location that forms an invalid instruction results in a NOP.

15.1.1 FSR and INDF Access

The File Select (FSR) and INDF registers allow indirect access to the Program Flash Memory. Indirect addressing is a mode in which the memory address in the instruction is determined by another register. The value of the FSR registers is used to determine the memory address location to be accessed.

15.1.1.1 FSR Read

The FSRs are used to provide read access to program memory.

Program memory is accessed by loading the FSRxH:FSRxL register pair with the address to be read and setting bit 7 of the FSRxH register to '1'. When a `MOVW` instruction, or any instruction that accesses INDFx, is executed, the value loaded into the FSRx register pair points to the location in program memory to be accessed. If the FSRx register pair points to an INDFx register, the read will return '0'.

Reading from NVM requires one instruction cycle. The CPU operation is suspended during the read and resumes immediately after. Read operations return a single byte of memory.

15.1.1.2 FSR Write

Writing/erasing the NVM through the FSR registers (e.g., the `MOVWI` instruction) is not supported in the PIC16F181 microcontroller family.

15.1.2 NVMREG Access

The NVMREG interface allows read/write access to all the locations accessible by FSRs, read/write access to the User ID locations and Configuration words, and read-only access to the Device ID and Revision ID registers.

Writing or erasing of NVM via the NVMREG interface is prevented when the device is write-protected.

15.1.2.1 NVMREG Read Operation

To read a NVM location using the NVMREG interface, the user must:

1. Clear the `NVMREGS` bit if the user intends to access program memory locations, or set `NVMREGS` if the user intends to access User ID or configuration locations.
2. Write the desired address into the `NVMADRH:NVMADRL` register pair.
3. Set the `RD` bit to initiate the read.

Once the read control bit is set, the CPU operation is suspended during the read and resumes immediately after. The data are available in the very next cycle, in the `NVMDATH:NVMDATL` register pair; therefore, it can be read as two bytes in the following instructions.

The `NVMDATH:NVMDATL` register pair will hold this value until another read or until it is written to by the user.

Upon completion, the `RD` bit is cleared by hardware.

Figure 15-1. Program Flash Memory Read Sequence

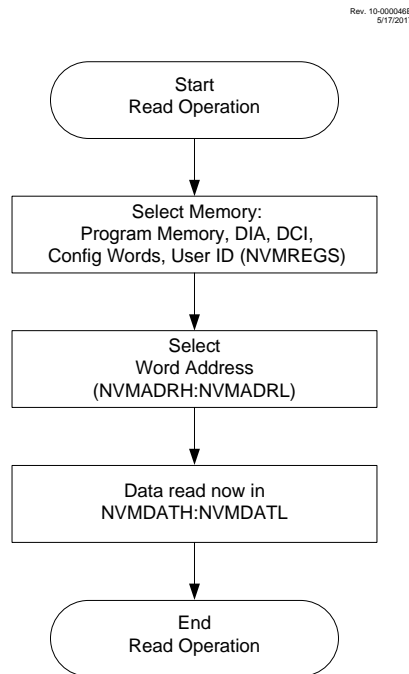
**Example 15-1. Program Memory Read**

```

// This code block will read 1 word of program memory
NVMCON1bits.NVMREGS = 0;           // Point to PFM
NVMADR = PFM_ADDRESS;              // Load NVMADRH:NVMADRL with PFM address
NVMCON1bits.RD = 1;                // Initiate read cycle
PFM_DATA_LOW = NVMDATL;             // PFM data low byte
PFM_DATA_HIGH = NVMDATH;           // PFM data high byte
  
```

15.1.2.2 NVM Unlock Sequence

The unlock sequence is a mechanism that protects the NVM from unintended self-write programming or erasing. The sequence must be executed and completed without interruption to successfully complete any of the following operations:

- PFM Row Erase
- Write of PFM write latches to PFM memory
- Write of PFM write latches to User IDs
- Write to Configuration Words

The unlock sequence consists of the following steps and must be completed in order:

- Write 55h to [NVMCON2](#)
- Write AAh to [NVMCON2](#)
- Set the [WR](#) bit

Once the WR bit is set, the processor will stall internal operations until the operation is complete and then resume with the next instruction.

Since the unlock sequence must not be interrupted, global interrupts must be disabled prior to the unlock sequence and re-enabled after the unlock sequence is completed.

Figure 15-2. NVM Unlock Sequence

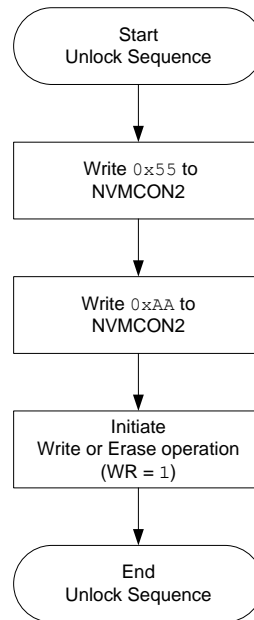
Rev. 10-000047B
8/24/2015**Example 15-2. NVM Unlock Sequence**

```

NVMCON1bits.WREN = 1;           // Enable write/erase
INTCONbits.GIE = 0;             // Disable global interrupts

// The next three steps are the required unlock sequence
NVMCON2 = 0x55;                 // First unlock code
NVMCON2 = 0xAA;                 // Second unlock code
NVMCON1bits.WR = 1;             // Initiate write/erase cycle

INTCONbits.GIE = 1;             // Enable global interrupts
NVMCON1bits.WREN = 0;           // Disable further write/erase cycles
  
```

Note: Sequence begins when NVMCON2 is written; the three unlock steps must occur in the cycle-accurate order shown. If the timing of the sequence is corrupted by an interrupt or a debugger Halt, the action will not take place.

15.1.2.3 NVMREG Erase of Program Memory

Before writing to program memory, the word(s) to be written must be erased or previously unwritten. Program memory can only be erased one row at a time. No automatic erase occurs upon the initiation of the write to program memory. To erase a program memory row:

1. Clear the **NVMREGS** bit to erase program memory locations, or set the **NMVREGS** bit to erase User ID locations.
2. Write the desired address into the **NVMADRH:NVMADRL** register pair.
3. Set the **FREE** and **WREN** bits.
4. Perform the unlock sequence as described in the **NVM Unlock Sequence** section.

If the program memory address is write-protected, the **WR** bit will be cleared and the erase operation will not take place.

While erasing program memory, the CPU operation is suspended and resumes when the operation is complete. Upon completion, the NVMIF bit is set, and an interrupt will occur if the NVMIE bit is also set.

Write latch data are not affected by erase operations, and WREN will remain unchanged.

Figure 15-3. NVM Erase Sequence

Rev. 10-000048B
8/24/2015

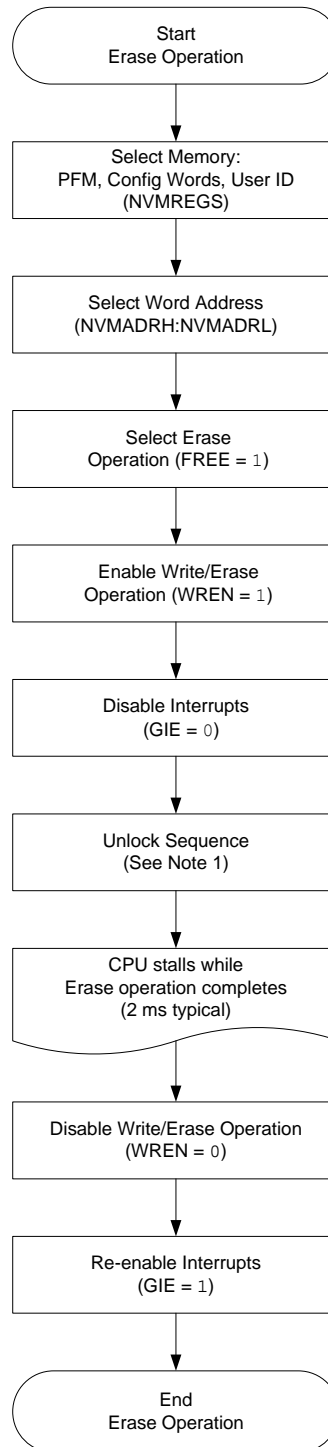

Note:

1. See the [NVM Unlock Sequence](#) section.

Example 15-3. Erasing One Row of Program Flash Memory

```

NVMCON1bits.NVMREGS = 0;           // Point to PFM
NVMADR = PFM_ADD;                 // 14-bit PFM address
NVMCON1bits.FREE = 1;             // Specify an erase operation
NVMCON1bits.WREN = 1;             // Enable write/erase cycle
INTCONbits.GIE = 0;               // Disable interrupts during unlock sequence

//The next three steps are the required unlock sequence
NVMCON2 = 0x55;                   // First unlock code
NVMCON2 = 0xAA;                   // Second unlock code
NVMCON1bits.WR = 1;               // Initiate write/erase cycle

INTCONbits.GIE = 1;               // Enable interrupts
NVMCON1bits.WREN = 1;             // Disable writes

```

15.1.2.4 NVMREG Write to Program Memory

Program memory is programmed using the following steps:

1. Load the address of the row to be programmed into [NVMADRH:NVMADRL](#).
2. Load each write latch with data via the [NVMDATH:NVMDATL](#) registers.
3. Initiate a programming operation.
4. Repeat steps 1 through 3 until all data are written.

Before writing to program memory, the word(s) to be written must be erased or previously unwritten. Program memory can only be erased one row at a time. No automatic erase occurs upon the initiation of the write.

Program memory can be written one or more words at a time. The maximum number of words written at one time is equal to the number of write latches. See [Figure 15-4](#) for more details.

The write latches are aligned to the Flash row address boundary defined by the upper ten bits of [NVMADRH:NVMADRL](#), ([NVMADRH\[6:0\]:NVMADRL\[7:5\]](#)) with the lower five bits of [NVMADRL](#), ([NVMADRL\[4:0\]](#)) determining the write latch being loaded. Write operations do not cross these boundaries. At the completion of a program memory write operation, the data in the write latches is reset to contain 0x3FFF.

The following steps must be completed to load the write latches and program a row of program memory. These steps are divided into two parts. First, each write latch is loaded with data from the [NVMDATH:NVMDATL](#) using the unlock sequence with [LWLO](#) = 1. When the last word to be loaded into the write latch is ready, the [LWLO](#) bit is cleared and the unlock sequence executed. This initiates the programming operation, writing all the latches into Flash program memory.



Important: The special unlock sequence is required to load a write latch with data or initiate a Flash programming operation. If the unlock sequence is interrupted, writing to the latches or program memory will not be initiated.

1. Set the [WREN](#) bit.
2. Clear the [NVMREGS](#) bit.
3. Set the [LWLO](#) bit. When the [LWLO](#) bit is set ([LWLO](#) = 1), the write sequence will only load the write latches and will not initiate the write to Program Flash Memory.
4. Load the [NVMADRH:NVMADRL](#) register pair with the address of the location to be written.
5. Load the [NVMDATH:NVMDATL](#) register pair with the program memory data to be written.
6. Execute the unlock sequence. The write latch is now loaded.

7. Increment the NVMADRH:NVMADRL register pair to point to the next location.
8. Repeat steps 5 through 7 until all except the last write latch has been loaded.
9. Clear the LWLO bit. When the LWLO bit is clear ($LWLO = 0$), the write sequence will initiate the write to Program Flash Memory.
10. Load the NVMDATH:NVMDATL register pair with the program memory data to be written.
11. Execute the unlock sequence. The entire program memory latch content is now written to Flash program memory.



Important: The program memory write latches are reset to the Blank state (0x3FFF) at the completion of every write or erase operation. As a result, it is not necessary to load all the program memory write latches. Unloaded latches will remain in the Blank state.

An example of the complete write sequence is shown in [Example 15-4](#). The initial address is loaded into the NVMADRH:NVMADRL register pair; the data are loaded using indirect addressing.

Figure 15-4. NVMREG Writes to Program Flash Memory with 32 Write Latches

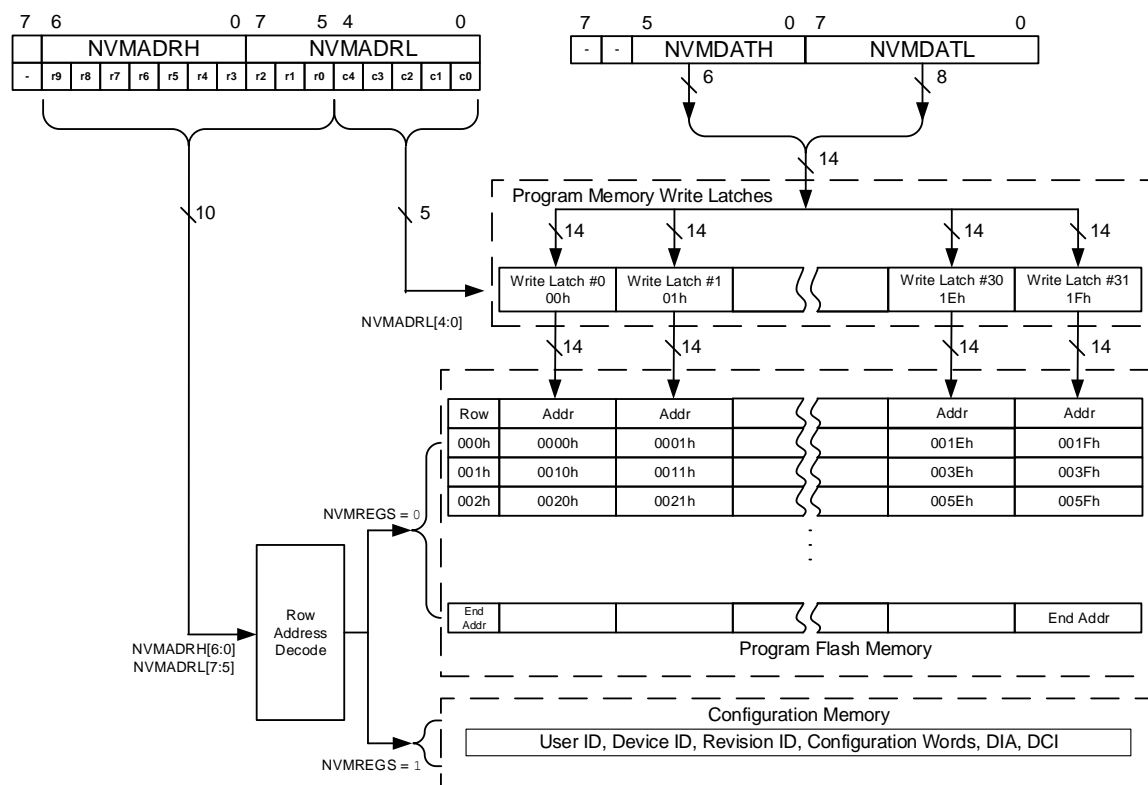

Figure 15-5. Program Flash Memory Write Sequence



Note:

1. See the [NVM Unlock Sequence](#) section.

Example 15-4. Writing to Program Flash Memory

```

INTCONbits.GIE = 0;                // Disable interrupts

// PFM row must be erased before writes can occur
NVMCON1bits.NVMREGS = 0;           // Point to PFM
NVMADR = PFMStartAddress;          // Must start at beginning of PFM row
NVMCON1bits.FREE = 1;              // Specify an erase operation
NVMCON1bits.WREN = 1;              // Allow erase cycle

// Required unlock sequence
NVMCON2 = 0x55;
NVMCON2 = 0xAA;
NVMCON1bits.WR = 1;

NVMCON1bits.LWLO = 1;              // Load write latches

// Write to the data latches
for (i = 0; i < PFM_ROW_SIZE; i++)
{
    NVMADR = PFMStartAddress;       // Load starting address
    NVMDAT = PFM_WRITE_DATA;        // Load data

    // Required unlock sequence
    NVMCON2 = 0x55;
    NVMCON2 = 0xAA;
    NVMCON1bits.WR = 1;

    PFMStartAddress++;              // Increment address
    if (i == (PFM_ROW_SIZE - 1))    // All latches loaded?
    {
        NVMCON1bits.LWLO = 0;       // Start PFM write
    }
}

NVMCON1bits.WREN = 0;              // Disable writes
INTCONbits.GIE = 1;                // Enable interrupts

```

15.1.2.5 Modifying Flash Program Memory

When modifying existing data in a program memory, data within the memory row must be read and saved in a RAM image. Program memory is modified using the following steps:

1. Load the starting address of the row to be modified.
2. Read the existing data from the row into a RAM image.
3. Modify the RAM image to contain the new data to be written into program memory.
4. Load the starting address of the row to be rewritten.
5. Erase the program memory row.
6. Load the write latches with data from the RAM image.
7. Initiate a programming operation.

Figure 15-6. Program Flash Memory Modify Sequence

Rev. 10-000050B
8/21/2015

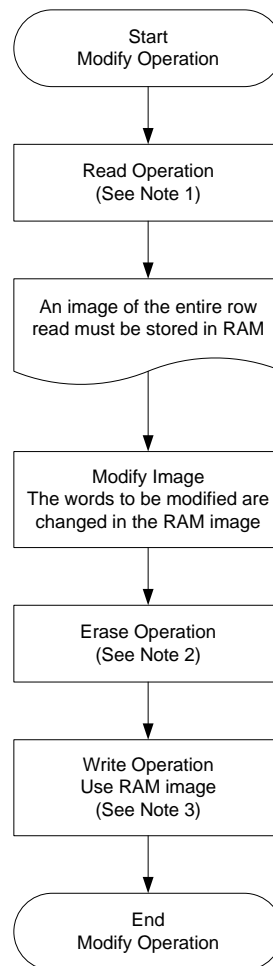

Notes:

1. See [Figure 15-1](#).
2. See [Figure 15-3](#).
3. See [Figure 15-5](#).

15.1.2.6 NVMREG Access to DIA, DCI, User ID, Device ID, Revision ID, and Configuration Words

NVMREGS can be used to access the following memory regions:

- Device Information Area (DIA)
- Device Configuration Information (DCI)
- User ID region
- Device ID and Revision ID
- Configuration Words

The value of `NVMREGS` is set to '1' to access these regions. The memory regions listed above will be pointed to by `PC[15] = 1`, but not all addresses reference valid data. Different access may exist for reads and writes. Refer to the table below. When read access is initiated on an address outside the parameters listed in the following table, the `NVMDATH: NVMDATL` register pair is cleared, reading back '0's.

Table 15-2. NVMREG Access to DIA, DCI, User ID, Device ID, Revision ID and Configuration Words (NVMREGS = 1)

Address	Function	Read Access	Write Access
0x8000 - 0x8003	User IDs	Yes	Yes
0x8005 - 0x8006	Device ID/Revision ID	Yes	No
0x8007 - 0x800B	Configuration Words 1-5	Yes	Yes
0x8100 - 0x82FF	DIA and DCI	Yes	No
0xF000 - 0xF0FF	EEPROM	Yes	Yes

15.1.2.7 Write Verify

It is considered good programming practice to verify that program memory writes agree with the intended value. Since program memory is stored as a full row then the stored program memory contents are compared with the intended data stored in RAM after the last write is complete.

Figure 15-7. Program Flash Memory Write Verify Sequence

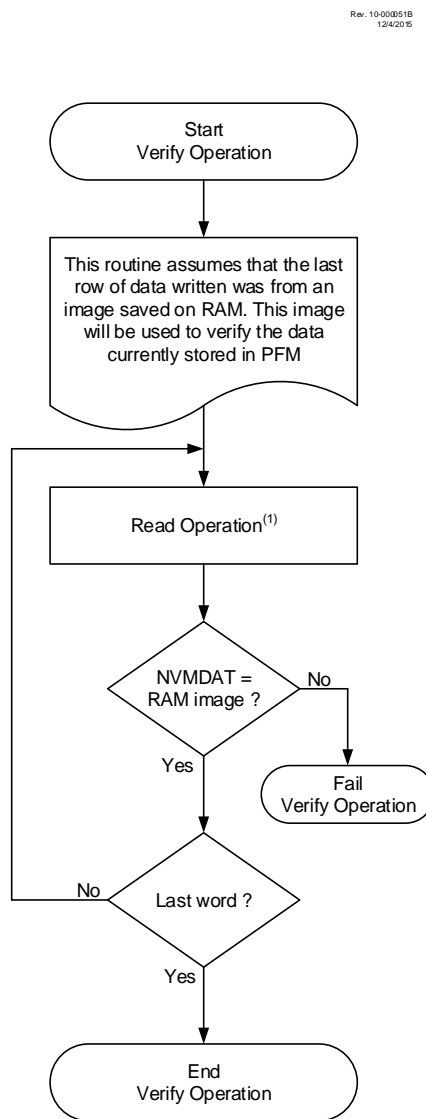

Note:

1. See [Figure 15-1](#).

15.1.2.8 WRERR Bit

The **WRERR** bit can be used to determine if a write error occurred. WRERR will be set if one of the following conditions occurs:

- If **WR** is set while the **NVMADRH:NVMADRL** points to a write-protected address
- A Reset occurs while a self-write operation was in progress
- An unlock sequence was interrupted

The WRERR bit is normally set by hardware, but can be set by the user for test purposes. Once set, WRERR must be cleared in software.

Table 15-3. Actions for PFM When WR = 1

Free	LWLO	Actions for PFM when WR = 1	Comments
1	x	Erase the 32-word row of NVMADRH:NVMADRL location.	<ul style="list-style-type: none"> • If WP is enabled, WR is cleared and WRERR is set • All 32 words are erased • NVMDATH:NVMDATL is ignored
0	1	Copy NVMDATH:NVMDATL to the write latch corresponding to NVMADR LSBs.	<ul style="list-style-type: none"> • Write protection is ignored • No memory access occurs
0	0	Write the write-latch data to PFM row.	<ul style="list-style-type: none"> • If WP is enabled, WR is cleared and WRERR is set • Write latches are reset to 0x3FFF • NVMDATH:NVMDATL is ignored

15.2 Data Flash Memory (DFM)

The Data Flash Memory is a nonvolatile memory array, also referred to as EEPROM. The DFM is mapped above program memory space. The DFM can be accessed using the FSRs or NVM Special Function Registers (SFRs). The DFM is readable and writable during normal operation over the entire V_{DD} range.

The DFM can only be read and written one byte at a time. When interfacing to the data memory block, the **NVMDATL** register holds the 8-bit data for read/write and the **NVMADR** register pair holds the address of the DFM location being accessed.

The DFM is rated for high erase/write cycle endurance. A byte write automatically erases the location and writes the new data (erase-before-write). The write time is controlled by an internal programming timer; it will vary with voltage and temperature as well as from device-to-device. Refer to the data EEPROM memory parameters in the **“Electrical Specifications”** chapter for more information.

15.2.1 FSR and INDF Access

The File Select (FSR) and INDF registers allow read-only access to the DFM. The value of the FSR registers is used to determine the memory address location to be accessed.

15.2.1.1 FSR DFM Read

DFM is accessed by loading the FSRxH:FSRxL register pair with the address to be read and loading bits [7-4] of the FSRxH register with a value of '0111'. When a **MOVIW** instruction, or any instruction that accesses INDFx, is executed, the value loaded into the FSRx register pair points to the location in program memory to be accessed. If the FSRx register pair points to an unimplemented address location, the read will return '0'.

15.2.1.2 FSR DFM Write

Writing/erasing the DFM through the FSR registers (e.g., the **MOVWI** instruction) is not supported in the PIC16F181 microcontroller family.

15.2.2 NVMREG Access

The NVMREG interface allows read/write access to the DFM.

Writing or erasing of DFM via the NVMREG interface is prevented when the DFM is write-protected (Configuration bit $\overline{\text{WRTD}} = '0'$).

15.2.2.1 NVMREG Read Operation

To read a DFM location using the NVMREG interface, the user must:

1. Set the [NVMREGS](#) bit.
2. Write the desired address into the [NVMADRH:NVMADRL](#) register pair.
3. Set the [RD](#) bit to initiate the read.

Once the read control bit is set, the CPU operation is suspended during the read and resumes immediately after. The data are available in the very next cycle, in the [NVMDATL](#) register; therefore, it can be read in the following instructions.

The NVMDATL register will hold this value until another read or until it is written to by the user.

Upon completion, the RD bit is cleared by hardware.

Figure 15-8. Program Flash Memory Read Sequence

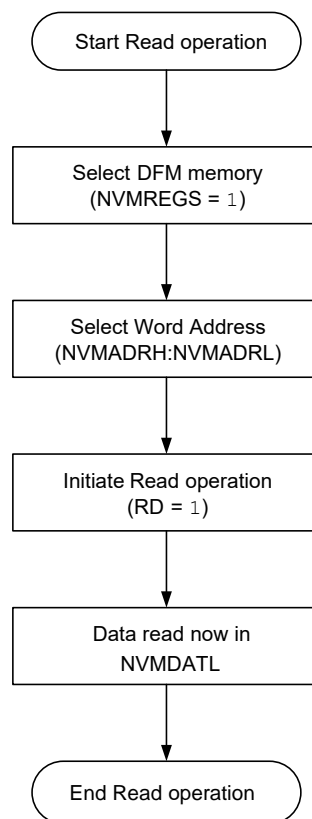

Example 15-5. DFM Read

```

// This code block will read 1 word (byte) of DFM
NVMCON1bits.NVMREGS = 1;           // Point to DFM
NVMADR = DFM_ADDRESS;             // NVMADRH = 0x70, NVMADRL = DFM address
  
```

```
NVMCON1bits.RD = 1;           // Initiate read cycle
MY_8BIT_VARIABLE = NVMDATL;   // DFM data byte is in NVMDATL
```

15.2.2.2 NVM Unlock Sequence

The unlock sequence is a mechanism that protects the DFM from unintended self-write programming or erasing. The sequence must be executed and completed without interruption to successfully complete an erase or write operation.

The unlock sequence consists of the following steps and must be completed in order:

- Write 55h to **NVMCON2**
- Write AAh to **NVMCON2**
- Set the **WR** bit

Once the WR bit is set, the processor will stall internal operations until the operation is complete and then resume with the next instruction.

Since the unlock sequence must not be interrupted, global interrupts must be disabled prior to the unlock sequence and re-enabled after the unlock sequence is completed.

Figure 15-9. NVM Unlock Sequence

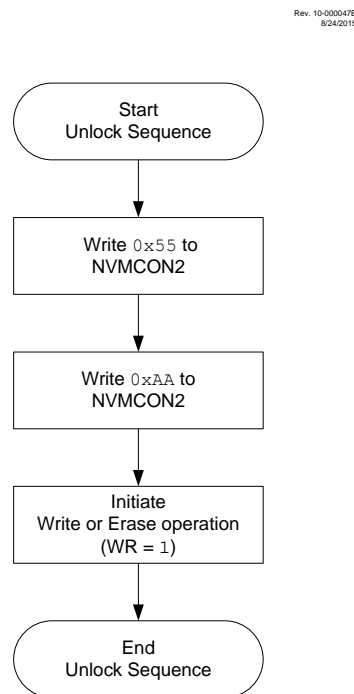

Example 15-6. NVM Unlock Sequence

```
NVMCON1bits.WREN = 1;           // Enable write/erase
INTCONbits.GIE = 0;           // Disable global interrupts

// The next three steps are the required unlock sequence
NVMCON2 = 0x55;               // First unlock code
NVMCON2 = 0xAA;               // Second unlock code
NVMCON1bits.WR = 1;           // Initiate write/erase cycle
```

```
INTCONbits.GIE = 1;           // Enable global interrupts
NVMCON1bits.WREN = 0;        // Disable further write/erase cycles
```

Note: Sequence begins when NVMCON2 is written; the three unlock steps must occur in the cycle-accurate order shown. If the timing of the sequence is corrupted by an interrupt or a debugger Halt, the action will not take place.

15.2.2.3 NVMREG Erase of DFM

DFM can be erased by writing '0xFF' to all locations that need to be erased. To erase a DFM word:

1. Set the [NVMREGS](#) bit.
2. Write the desired address into the [NVMADRH:NVMADRL](#) register pair.
3. Set the [WREN](#) bit.
4. Perform the unlock sequence as described in the [NVM Unlock Sequence](#) section.
5. Set the [WR](#) bit.

A single byte (0xFF) is written into the DFM location. The DFM circuitry automatically erases the memory location before performing the write operation. If the DFM address is write-protected, the WR bit will be cleared and the write operation will not take place. Upon completion, hardware clears the WR bit, the NVMIF bit is set, and an interrupt will occur if the NVMIE bit is also set.

Figure 15-10. DFM Erase Sequence

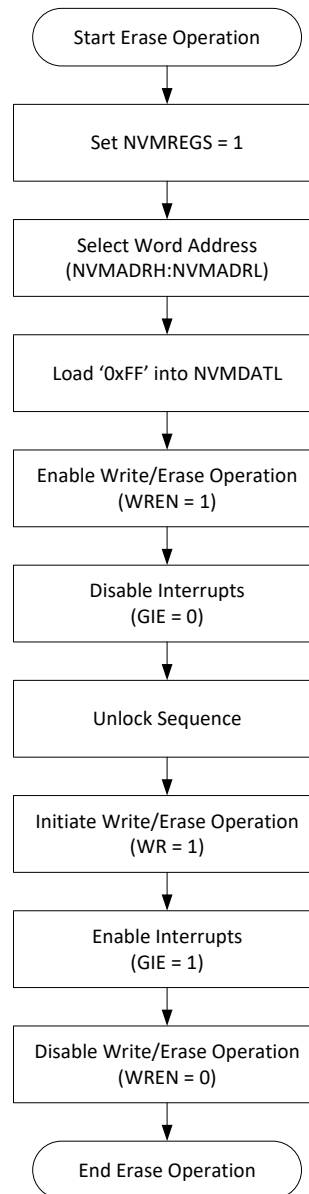

Example 15-7. Erasing One Byte of Data Flash Memory

```

// Code sequence to erase one byte of DFM
NVMCON1bits.NVMREGS = 1;           // Point to DFM
NVMADR = DFM_ADDR;                 // NVMADRH = 0x70, NVMADRL = DFM address
NVMDATL = 0xFF;                    // Load NVMDATL with 0xFF
NVMCON1bits.WREN = 1;              // Allows program/erase cycles
INTCONbits.GIE = 0;                // Disable interrupts

// Perform required unlock sequence
NVMCON2 = 0x55;
NVMCON2 = 0xAA;
  
```

```

NVMCON1bits.WR = 1;           // Begin program/erase cycle

INTCONbits.GIE = 1;          // Restore interrupt enable bit value
NVMCON1bits.WREN = 0;        // Disable program/erase

// Verify byte erase operation success and call the recovery function if needed
if (NVMCON1bits.WRERR)
{
    ERASE_FAULT_RECOVERY();
}

```

15.2.2.4 NVMREG Write to DFM

DFM is programmed using the following steps:

1. Set the [NVMREGS](#) bit.
2. Load the [NVMADRH:NVMADRL](#) registers with the DFM address.
3. Load the [NVMDATL](#) register with the data byte to be written.
4. Set the [WREN](#) bit to allow write/erase cycles.
5. Disable the GIE bit.
6. Perform the [NVM Unlock Sequence](#).
7. Set the [WR](#) bit.

A single byte (0xFF) is written into the DFM location. The DFM circuitry automatically erases the memory location before performing the write operation. If the DFM address is write-protected, the WR bit will be cleared and the write operation will not take place. Upon completion, hardware clears the WR bit, the NVMIF bit is set, and an interrupt will occur if the NVMIE bit is also set.

15.2.2.5 WRERR Bit

The [WRERR](#) bit can be used to determine if a write error occurred. WRERR will be set if one of the following conditions occurs:

- If [WR](#) is set while the [NVMADRH:NVMADRL](#) points to a write-protected DFM address
- A Reset occurs while a self-write operation was in progress
- An unlock sequence was interrupted

The WRERR bit is normally set by hardware, but can be set by the user for test purposes. Once set, WRERR must be cleared in software.

15.3 Register Definitions: Nonvolatile Memory Control

15.3.1 NVMADR

Name: NVMADR

Offset: 0x1C8C

Nonvolatile Memory Address Register

Bit	15	14	13	12	11	10	9	8
	NVMADR[14:8]							
Access		R/W	R/W	R/W	R/W	R/W	R/W	R/W
Reset		0	0	0	0	0	0	0
Bit	7	6	5	4	3	2	1	0
	NVMADR[7:0]							
Access	R/W	R/W	R/W	R/W	R/W	R/W	R/W	R/W
Reset	0	0	0	0	0	0	0	0

Bits 14:0 – NVMADR[14:0] NVM Address Bits

Notes:

- The individual bytes in this multibyte register can be accessed with the following register names:
 - NVMADRH: Accesses the high byte NVMADR[15:8]
 - NVMADRL: Accesses the low byte NVMADR[7:0].
- Bit [15] is undefined while WR = 1.

15.3.2 NVMDAT

Name: NVMDAT
Offset: 0x1C8E

Nonvolatile Memory Data Register

Bit	15	14	13	12	11	10	9	8
			NVMDAT[13:8]					
Access			R/W	R/W	R/W	R/W	R/W	R/W
Reset			x	x	x	x	x	x
Bit	7	6	5	4	3	2	1	0
	NVMDAT[7:0]							
Access	R/W	R/W	R/W	R/W	R/W	R/W	R/W	R/W
Reset	x	x	x	x	x	x	x	x

Bits 13:0 – NVMDAT[13:0] NVM Data bits

Reset States: POR/BOR = xxxxxxxxxxxxxxxx

All Other Resets = uuuuuuuuuuuuuuuu

Notes: The individual bytes in this multibyte register can be accessed with the following register names:

- NVMDATH: Accesses the high byte NVMDAT[13:8]
- NVMDATL: Accesses the low byte NVMDAT[7:0]

15.3.3 NVMCON1

Name: NVMCON1

Offset: 0x1C90

Nonvolatile Memory Control 1 Register

Bit	7	6	5	4	3	2	1	0
		NVMREGS	LWLO	FREE	WRERR	WREN	WR	RD
Access		R/W	R/W	R/S/HC	R/W/HS	R/W	R/S/HC	R/S/HC
Reset		0	0	0	0	0	0	0

Bit 6 – NVMREGS NVM Region Selection

Value	Description
1	Access DFM (EEPROM), DIA, DCI, Configuration, User ID, Revision ID, and Device ID Registers
0	Access Program Flash Memory

Bit 5 – LWLO Load Write Latches Only

Value	Condition	Description
1	When FREE = 0	The next WR command updates the write latch for this word within the row; no memory operation is initiated
0	When FREE = 0	The next WR command writes data or erases
–	Otherwise:	This bit is ignored

Bit 4 – FREE Program Flash Memory Erase Enable

Value	Description
1	Performs an erase operation with the next WR command; the 32-word pseudo-row containing the indicated address is erased (to all 1s) to prepare for writing
0	The next WR command writes without erasing

Bit 3 – WRERR

Write-Reset Error Flag^(1,2,3)

Value	Description
1	A write operation error has occurred
0	All write operations have completed normally

Bit 2 – WREN Program/Erase Enable

Value	Description
1	Allows program/erase cycles
0	Inhibits programming/erasing of program Flash

Bit 1 – WR Write Control^(4,5,6)

Value	Description
1	Initiates the program/erase operation at the corresponding NVM location
0	NVM program/erase operation is complete and inactive

Bit 0 – RD Read Control

Value	Description
1	Initiates a read at address = NVMADR
0	NVM read operation is complete and inactive

Notes:

1. Bit is undefined while $WR = 1$.
2. Bit must be cleared by software; hardware will not clear this bit.
3. Bit may be written to '1' by the user to implement test sequences.
4. This bit can only be set by following the sequence described in the **"NVM Unlock Sequence"** section.
5. Operations are self-timed and the WR bit is cleared by hardware when complete.
6. Once a write operation is initiated, setting this bit to zero will have no effect.

15.3.4 NVMCON2

Name: NVMCON2
Offset: 0x1C91

Nonvolatile Memory Control 2 Register

Bit	7	6	5	4	3	2	1	0
	NVMCON2[7:0]							
Access	WO	WO	WO	WO	WO	WO	WO	WO
Reset	0	0	0	0	0	0	0	0

Bits 7:0 – NVMCON2[7:0] Flash Memory Unlock Pattern bits

Note: To unlock writes, a 0x55 must be written first followed by an 0xAA before setting the WR bit of the NVMCON1 register. The value written to this register is used to unlock the writes.

15.4 Register Summary - NVM Control

Offset	Name	Bit Pos.	7	6	5	4	3	2	1	0
0x00 ... 0x1C8B	Reserved									
0x1C8C	NVMADR	7:0	NVMADR[7:0]							
		15:8	NVMADR[14:8]							
0x1C8E	NVMDAT	7:0	NVMDAT[7:0]							
		15:8	NVMDAT[13:8]							
0x1C90	NVMCON1	7:0		NVMREGS	LWLO	FREE	WRERR	WREN	WR	RD
0x1C91	NVMCON2	7:0	NVMCON2[7:0]							

16. I/O Ports

16.1 Overview

Table 16-1. Port Availability per Device

Device	PORTA	PORTB	PORTC
14/16-pin devices	•		•
20-pin devices	•	•	•

Each port has eight registers to control the operation. These registers are:

- **PORTx** registers (reads the levels on the pins of the device)
- **LATx** registers (output latch)
- **TRISx** registers (data direction)
- **ANSELx** registers (analog select)
- **WPUx** registers (weak pull-up)
- **INLVLx** (input level control)
- **SLRCONx** registers (slew rate control)
- **ODCONx** registers (open-drain control)

In this section, the generic names such as PORTx, LATx, TRISx, etc. can be associated with PORTA, PORTB, PORTC, etc., depending on availability per device.

A simplified model of a generic I/O port, without the interfaces to other peripherals, is shown in the following figure:

Figure 16-1. Generic I/O Port Operation

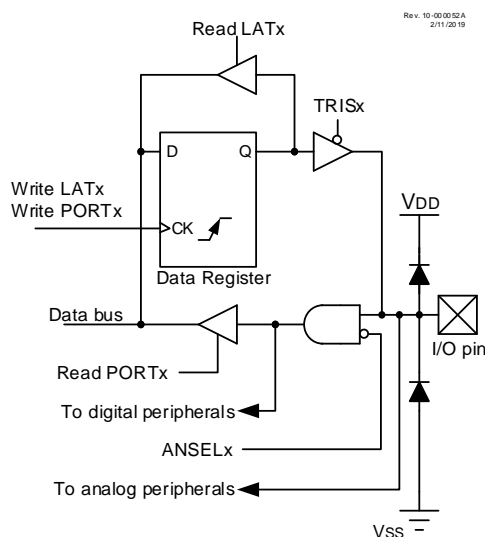

16.2 PORTx - Data Register

PORTx is a bidirectional port and its corresponding data direction register is **TRISx**.

Reading the **PORTx** register reads the status of the pins, whereas writing to it will write to the **PORT** latch. All write operations are Read-Modify-Write operations. Therefore, a write to a port implies that

the PORT pins are read, and this value is modified and then written to the PORT data latch (LATx). The PORT data latch LATx holds the output port data and contains the latest value of a LATx or PORTx write. The example below shows how to initialize PORTA.

Example 16-1. Initializing PORTA in Assembly

```
; This code example illustrates initializing the PORTA register.
; The other ports are initialized in the same manner.

BANKSEL    PORTA        ;
CLRF       PORTA        ;Clear PORTA
BANKSEL    LATA         ;
CLRF       LATA         ;Clear Data Latch
BANKSEL    ANSELA       ;
CLRF       ANSELA       ;Enable digital drivers
BANKSEL    TRISA        ;
MOVLW     B'00111000'   ;Set RA[5:3] as inputs
MOVWF     TRISA         ;and set others as outputs
```

Example 16-2. Initializing PORTA in C

```
// This code example illustrates initializing the PORTA register.
// The other ports are initialized in the same manner.

PORTA = 0x00;          // Clear PORTA
LATA  = 0x00;          // Clear Data Latch
ANSELA = 0x00;         // Enable digital drivers
TRISA = 0x38;         // Set RA[5:3] as inputs and set others as outputs
```



Important: Most PORT pins share functions with device peripherals, both analog and digital. In general, when a peripheral is enabled on a PORT pin, that pin cannot be used as a general purpose output; however, the pin can still be read.

16.3 LATx - Output Latch

The Data Latch (LATx registers) is useful for Read-Modify-Write operations on the value that the I/O pins are driving.

A write operation to the LATx register has the same effect as a write to the corresponding PORTx register. A read of the LATx register reads the values held in the I/O PORT latches, while a read of the PORTx register reads the actual I/O pin value.



Important: As a general rule, output operations to a port must use the LAT register to avoid Read-Modify-Write issues. For example, a bit set or clear operation reads the port, modifies the bit, and writes the result back to the port. When two bit operations are executed in succession, output loading on the changed bit may delay the change at the output in which case the bit will be misread in the second bit operation and written to an unexpected level. The LAT registers are isolated from the port loading and therefore changes are not delayed.

16.4 TRISx - Direction Control

The TRISx register controls the PORTx pin output drivers, even when the pins are being used as analog inputs. The user must ensure the bits in the TRISx register are set when using the pins as analog inputs. I/O pins configured as analog inputs always read '0'.

Setting a TRISx bit (TRISx = 1) will make the corresponding PORTx pin an input (i.e., disable the output driver). Clearing a TRISx bit (TRISx = 0) will make the corresponding PORTx pin an output (i.e., it enables output driver and puts the contents of the output latch on the selected pin).

16.5 ANSELx - Analog Control

Ports that support analog inputs have an associated ANSELx register. The ANSELx register is used to configure the Input mode of an I/O pin to analog. Setting an ANSELx bit high will disable the digital input buffer associated with that bit and cause the corresponding input value to always read '0', whether the value is read in PORTx register or selected by PPS as a peripheral input.

Disabling the input buffer prevents analog signal levels on the pin between a logic high and low from causing excessive current in the logic input circuitry.

The state of the ANSELx bits has no effect on digital or analog output functions. A pin with TRIS clear and ANSEL set will still operate as a digital output, but the Input mode will be analog. This can cause unexpected behavior when executing Read-Modify-Write instructions on the PORTx register.



Important: The ANSELx bits default to the Analog mode after Reset. To use any pins as digital general purpose or peripheral inputs, the corresponding ANSEL bits must be changed to '0' by the user.

16.6 WPUx - Weak Pull-Up Control

The WPUx register controls the individual weak pull-ups for each PORT pin. When a WPUx bit is set (WPUx = 1), the weak pull-up will be enabled for the corresponding pin. When a WPUx bit is cleared (WPUx = 0), the weak pull-up will be disabled for the corresponding pin.

16.7 INLVx - Input Threshold Control

The INLVx register controls the input voltage threshold for each of the available PORTx input pins. A selection between the Schmitt Trigger CMOS and the TTL compatible thresholds is available. The input threshold is important in determining the value of a read of the PORTx register and also the level at which an interrupt-on-change occurs, if that feature is enabled. Refer to the I/O Ports table in the **“Electrical Specifications”** chapter for more details on threshold levels.



Important: Changing the input threshold selection must be performed while all peripheral modules are disabled. Changing the threshold level during the time a module is active may inadvertently generate a transition associated with an input pin, regardless of the actual voltage level on that pin.

16.8 SLRCONx - Slew Rate Control

The SLRCONx register controls the slew rate option for each PORT pin. Slew rate for each PORT pin can be controlled independently. When a SLRCONx bit is set (SLRCONx = 1), the corresponding PORT pin drive is slew rate limited. When a SLRCONx bit is cleared (SLRCONx = 0), the corresponding PORT pin drive slews at the maximum rate possible.

16.9 ODCONx - Open-Drain Control

The ODCONx register controls the open-drain feature of the port. Open-drain operation is independently selected for each pin. When a ODCONx bit is set (ODCONx = 1), the corresponding port output becomes an open-drain driver capable of sinking current only. When a ODCONx bit is cleared (ODCONx = 0), the corresponding port output pin is the standard push-pull drive capable of sourcing and sinking current.



Important: It is necessary to set open-drain control when using the pin for I²C.

16.10 Edge Selectable Interrupt-on-Change

An interrupt can be generated by detecting a signal at the PORT pin that has either a rising edge or a falling edge. Individual pins can be independently configured to generate an interrupt. Refer to the “**IOC - Interrupt-on-Change**” chapter for more details.

16.11 I²C Pad Control

For this family of devices, the I²C specific pads are available on RB4, RB5, RB6, and RB7 (20-pin devices only), and RC0, RC1, RC4, and RC5 (14/16-pin devices only) pins. The I²C characteristics of each of these pins is controlled by the [RxyI2C](#) registers. These characteristics include enabling I²C specific slew rate (over standard GPIO slew rate), selecting internal pull-ups for I²C pins, and selecting appropriate input threshold as per SMBus specifications.



Important: Any peripheral using the I²C pins reads the I²C input levels when enabled via RxyI2C.

16.12 I/O Priorities

Each pin defaults to the data latch after Reset. Other functions are selected with the Peripheral Pin Select logic. Refer to the “**PPS - Peripheral Pin Select Module**” chapter for more details.

Analog input functions, such as ADC and comparator inputs, are not shown in the Peripheral Pin Select lists. These inputs are active when the I/O pin is set for Analog mode using the [ANSELx](#) register. Digital output functions may continue to control the pin when it is in Analog mode.

Analog outputs, when enabled, take priority over digital outputs and force the digital output driver into a High-Impedance state.

The pin function priorities are as follows:

1. Port functions determined by the Configuration bits.
2. Analog outputs (input buffers must be disabled).
3. Analog inputs.
4. Port inputs and outputs from PPS.

16.13 $\overline{\text{MCLR}}/\text{V}_{\text{PP}}/\text{RA3}$ Pin

The $\overline{\text{MCLR}}/\text{V}_{\text{PP}}$ pin is an input-only pin. Its operation is controlled by the MCLRE Configuration bit. When selected as a PORT pin (MCLRE = 0), it functions as a digital input-only pin; as such, it does not have TRISx and LATx bits associated with its operation. Otherwise, it functions as the device's Master Clear input. In either configuration, the $\overline{\text{MCLR}}/\text{V}_{\text{PP}}$ pin also functions as the programming voltage input pin during high-voltage programming.

The $\overline{\text{MCLR}}/\text{V}_{\text{PP}}$ pin is a read-only bit and will read '1' when MCLRE = 1 (i.e., Master Clear enabled).



Important: On a Power-on Reset (POR), the $\overline{\text{MCLR}}/\text{V}_{\text{PP}}$ pin is enabled as a digital input-only if Master Clear functionality is disabled.

The $\overline{\text{MCLR}}/\text{V}_{\text{PP}}$ pin has an individually controlled internal weak pull-up. When set, the corresponding WPU bit enables the pull-up. When the $\overline{\text{MCLR}}/\text{V}_{\text{PP}}$ pin is configured as $\overline{\text{MCLR}}$ (MCLRE = 1 and LVP = 0)

or configured for Low-Voltage Programming (MCLRE = \times and LVP = 1), the pull-up is always enabled, and the WPU bit has no effect.

16.14 Register Definitions: Port Control

16.14.1 PORTx

Name: PORTx

PORTx Register

Bit	7	6	5	4	3	2	1	0
	Rx7	Rx6	Rx5	Rx4	Rx3	Rx2	Rx1	Rx0
Access	R/W	R/W	R/W	R/W	R/W	R/W	R/W	R/W
Reset	x	x	x	x	x	x	x	x

Bits 0, 1, 2, 3, 4, 5, 6, 7 – Rxn Port I/O Value

Reset States: POR/BOR = xxxxxxxx

All Other Resets = uuuuuuuu

Value	Description
1	PORT pin is $\geq V_{IH}$
0	PORT pin is $\leq V_{IL}$



Important:

- Writes to PORTx are actually written to the corresponding LATx register. Reads from PORTx register return actual I/O pin values.
- The PORT bit associated with the \overline{MCLR} pin is read-only and will read '1' when the \overline{MCLR} function is enabled (LVP = 1 or (LVP = 0 and MCLRE = 1))
- Refer to the **"Pin Allocation Table"** for details about \overline{MCLR} pin and pin availability per port
- Unimplemented bits will read back as '0'
- Bits RB6 and RB7 read '1' while in Debug mode

16.14.2 LATx

Name: LATx

Output Latch Register

Bit	7	6	5	4	3	2	1	0
	LATx7	LATx6	LATx5	LATx4	LATx3	LATx2	LATx1	LATx0
Access	R/W	R/W	R/W	R/W	R/W	R/W	R/W	R/W
Reset	x	x	x	x	x	x	x	x

Bits 0, 1, 2, 3, 4, 5, 6, 7 - LATxn Output Latch Value

Reset States: POR/BOR = xxxxxxxx

All Other Resets = uuuuuuuu



Important:

- Writes to LATx are equivalent to writes to the corresponding PORTx register. Reads from LATx register return register values, not I/O pin values.
- Refer to the **“Pin Allocation Table”** for details about pin availability per port
- Unimplemented bits will read back as ‘0’

16.14.3 TRISx

Name: TRISx

Tri-State Control Register

Bit	7	6	5	4	3	2	1	0
	TRISx7	TRISx6	TRISx5	TRISx4	TRISx3	TRISx2	TRISx1	TRISx0
Access	R/W	R/W	R/W	R/W	R/W	R/W	R/W	R/W
Reset	1	1	1	1	1	1	1	1

Bits 0, 1, 2, 3, 4, 5, 6, 7 – TRISxn Port I/O Tri-state Control

Value	Description
1	PORTx output driver is disabled. PORTx pin configured as an input (tri-stated).
0	PORTx output driver is enabled. PORTx pin configured as an output.



Important:

- The TRIS bit associated with the \overline{MCLR} pin is read-only and the value is '1'
- Refer to the **"Pin Allocation Table"** for details about \overline{MCLR} pin and pin availability per port
- Unimplemented bits will read back as '0'

16.14.4 ANSELx

Name: ANSELx

Analog Select Register

Bit	7	6	5	4	3	2	1	0
	ANSELx7	ANSELx6	ANSELx5	ANSELx4	ANSELx3	ANSELx2	ANSELx1	ANSELx0
Access	R/W	R/W	R/W	R/W	R/W	R/W	R/W	R/W
Reset	1	1	1	1	1	1	1	1

Bits 0, 1, 2, 3, 4, 5, 6, 7 – ANSELxn Analog Select on RX Pin

Value	Description
1	Analog input. Pin is assigned as analog input. Digital input buffer disabled.
0	Digital I/O. Pin is assigned to port or digital special function.



Important:

- When setting a pin as an analog input, the corresponding TRIS bit must be set to Input mode to allow external control of the voltage on the pin
- Refer to the “**Pin Allocation Table**” for details about pin availability per port
- Unimplemented bits will read back as ‘0’

16.14.5 WPUx

Name: WPUx

Weak Pull-Up Register

Bit	7	6	5	4	3	2	1	0
	WPUx7	WPUx6	WPUx5	WPUx4	WPUx3	WPUx2	WPUx1	WPUx0
Access	R/W	R/W	R/W	R/W	R/W	R/W	R/W	R/W
Reset	0	0	0	0	0	0	0	0

Bits 0, 1, 2, 3, 4, 5, 6, 7 – WPUxn Weak Pull-up PORTx Control

Value	Description
1	Weak pull-up enabled
0	Weak pull-up disabled



Important:

- The weak pull-up device is automatically disabled if the pin is configured as an output, but this register remains unchanged
- If MCLRE = 1, the weak pull-up on $\overline{\text{MCLR}}$ pin is always enabled and the corresponding WPU bit is not affected
- Refer to the **“Pin Allocation Table”** for details about pin availability per port
- Unimplemented bits will read back as ‘0’

16.14.6 INLVLx

Name: INLVLx

Input Level Control Register

Bit	7	6	5	4	3	2	1	0
	INLVLx7	INLVLx6	INLVLx5	INLVLx4	INLVLx3	INLVLx2	INLVLx1	INLVLx0
Access	R/W	R/W	R/W	R/W	R/W	R/W	R/W	R/W
Reset	1	1	1	1	1	1	1	1

Bits 0, 1, 2, 3, 4, 5, 6, 7 – INLVLxn Input Level Select on RX Pin

Value	Description
1	ST input used for port reads and interrupt-on-change
0	TTL input used for port reads and interrupt-on-change



Important:

- Refer to the “**Pin Allocation Table**” for details about pin availability per port
- Unimplemented bits will read back as ‘0’
- Any peripheral using the I²C pins read the I²C ST inputs when enabled via RxyI2C

16.14.7 SLRCONx

Name: SLRCONx

Slew Rate Control Register

Bit	7	6	5	4	3	2	1	0
	SLRx7	SLRx6	SLRx5	SLRx4	SLRx3	SLRx2	SLRx1	SLRx0
Access	R/W	R/W	R/W	R/W	R/W	R/W	R/W	R/W
Reset	1	1	1	1	1	1	1	1

Bits 0, 1, 2, 3, 4, 5, 6, 7 – SLRxn Slew Rate Control on RX Pin

Value	Description
1	PORT pin slew rate is limited
0	PORT pin slews at maximum rate



Important:

- Refer to the “**Pin Allocation Table**” for details about pin availability per port
- Unimplemented bits will read back as ‘0’

16.14.8 ODCONx

Name: ODCONx

Open-Drain Control Register

Bit	7	6	5	4	3	2	1	0
	ODCx7	ODCx6	ODCx5	ODCx4	ODCx3	ODCx2	ODCx1	ODCx0
Access	R/W	R/W	R/W	R/W	R/W	R/W	R/W	R/W
Reset	0	0	0	0	0	0	0	0

Bits 0, 1, 2, 3, 4, 5, 6, 7 – ODCxn Open-Drain Configuration on Rx Pin

Value	Description
1	PORT pin operates as open-drain drive (sink current only)
0	PORT pin operates as standard push-pull drive (source and sink current)



Important:

- Refer to the “**Pin Allocation Table**” for details about pin availability per port
- Unimplemented bits will read back as ‘0’

16.14.9 RxyI2C

Name: RxyI2C

I²C Pad Rxy Control Register

Bit	7	6	5	4	3	2	1	0
		SLEW	PU[1:0]				TH[1:0]	
Access		R/W	R/W	R/W			R/W	R/W
Reset		0	0	0			0	0

Bit 6 – SLEW I²C Specific Slew Rate Limiting Control

Value	Description
1	I ² C specific slew rate limiting is enabled. Standard pad slew limiting is disabled. The SLRxy bit is ignored
0	Standard GPIO Slew Rate; enabled/disabled via SLRxy bit

Bits 5:4 – PU[1:0] I²C Pull-Up Selection

Value	Description
11	Reserved
10	10x current of standard weak pull-up
01	2x current of standard weak pull-up
00	Standard GPIO weak pull-up, enabled via the WPUxy bit

Bits 1:0 – TH[1:0] I²C Input Threshold Selection

Value	Description
11	Reserved
10	SMBus 2.0 (2.1V) input threshold
01	I ² C-specific input thresholds
00	Standard GPIO Input pull-up, enabled via the INLVx registers



Important:

- Refer to the “**Pin Allocation Table**” for details about pin availability per port
- Unimplemented bits will read back as ‘0’

16.15 Register Summary - I/O Ports

Offset	Name	Bit Pos.	7	6	5	4	3	2	1	0
0x00	Reserved									
... 0x0B										
0x0C	PORTA	7:0			RA5	RA4	RA3	RA2	RA1	RA0
0x0D	PORTB	7:0	RB7	RB6	RB5	RB4				
0x0E	PORTC	7:0	RC7	RC6	RC5	RC4	RC3	RC2	RC1	RC0
0x0F	Reserved									
... 0x11										
0x12	TRISA	7:0			TRISA5	TRISA4	Reserved	TRISA2	TRISA1	TRISA0
0x13	TRISB	7:0	TRISB7	TRISB6	TRISB5	TRISB4				
0x14	TRISC	7:0	TRISC7	TRISC6	TRISC5	TRISC4	TRISC3	TRISC2	TRISC1	TRISCO
0x15	Reserved									
... 0x17										
0x18	LATA	7:0			LATA5	LATA4		LATA2	LATA1	LATA0
0x19	LATB	7:0	LATB7	LATB6	LATB5	LATB4				
0x1A	LATC	7:0	LATC7	LATC6	LATC5	LATC4	LATC3	LATC2	LATC1	LATC0
0x1B	Reserved									
... 0x1E8B										
0x1E8C	ANSELA	7:0			ANSELA5	ANSELA4		ANSELA2	ANSELA1	ANSELA0
0x1E8D	WPUA	7:0			WPUA5	WPUA4	WPUA3	WPUA2	WPUA1	WPUA0
0x1E8E	ODCONA	7:0			ODCA5	ODCA4		ODCA2	ODCA1	ODCA0
0x1E8F	SLRCONA	7:0			SLRA5	SLRA4		SLRA2	SLRA1	SLRA0
0x1E90	INLVLA	7:0			INLVLA5	INLVLA4	INLVLA3	INLVLA2	INLVLA1	INLVLA0
0x1E91	Reserved									
... 0x1E95										
0x1E96	ANSELB	7:0	ANSELB7	ANSELB6	ANSELB5	ANSELB4				
0x1E97	WPUB	7:0	WPUB7	WPUB6	WPUB5	WPUB4				
0x1E98	ODCONB	7:0	ODCB7	ODCB6	ODCB5	ODCB4				
0x1E99	SLRCONB	7:0	SLRB7	SLRB6	SLRB5	SLRB4				
0x1E9A	INLVLB	7:0	INLVLB7	INLVLB6	INLVLB5	INLVLB4				
0x1E9B	Reserved									
... 0x1E9F										
0x1EA0	ANSELC	7:0	ANSELC7	ANSELC6	ANSELC5	ANSELC4	ANSELC3	ANSELC2	ANSELC1	ANSELC0
0x1EA1	WPUC	7:0	WPUC7	WPUC6	WPUC5	WPUC4	WPUC3	WPUC2	WPUC1	WPUC0
0x1EA2	ODCONC	7:0	ODCC7	ODCC6	ODCC5	ODCC4	ODCC3	ODCC2	ODCC1	ODCC0
0x1EA3	SLRCONC	7:0	SLRC7	SLRC6	SLRC5	SLRC4	SLRC3	SLRC2	SLRC1	SLRC0
0x1EA4	INLVLC	7:0	INLVLC7	INLVLC6	INLVLC5	INLVLC4	INLVLC3	INLVLC2	INLVLC1	INLVLC0
0x1EA5	Reserved									
... 0x1EE4										
0x1EE5	RB4I2C	7:0		SLEW	PU[1:0]				TH[1:0]	
0x1EE6	RB5I2C	7:0		SLEW	PU[1:0]				TH[1:0]	
0x1EE7	RB6I2C	7:0		SLEW	PU[1:0]				TH[1:0]	
0x1EE8	RB7I2C	7:0		SLEW	PU[1:0]				TH[1:0]	
0x1EE9	RC0I2C	7:0		SLEW	PU[1:0]				TH[1:0]	
0x1EEA	RC1I2C	7:0		SLEW	PU[1:0]				TH[1:0]	
0x1EEB	Reserved									
0x1EEC	RC4I2C	7:0		SLEW	PU[1:0]				TH[1:0]	
0x1EED	RC5I2C	7:0		SLEW	PU[1:0]				TH[1:0]	

17. IOC - Interrupt-on-Change

17.1 Overview

The pins denoted in the table below can be configured to operate as interrupt-on-change (IOC) pins for this device. An interrupt can be generated by detecting a signal that has either a rising edge or a falling edge. Any individual PORT pin, or combination of PORT pins, can be configured to generate an interrupt.

Table 17-1. IOC Pin Availability per Device

Device	PORTA	PORTB	PORTC
14/16-pin devices	•		•
20-pin devices	•	•	•



Important: If MCLR = 1 or LVP = 1, the $\overline{\text{MCLR}}$ pin port functionality is disabled and IOC on that pin is not available.

The interrupt-on-change module has the following features:

- Interrupt-on-change enable (Host Switch)
- Individual pin configuration
- Rising and falling edge detection
- Individual pin interrupt flags

The following figure is a block diagram of the IOC module.

Figure 17-1. Interrupt-on-Change Block Diagram (PORTA Example)

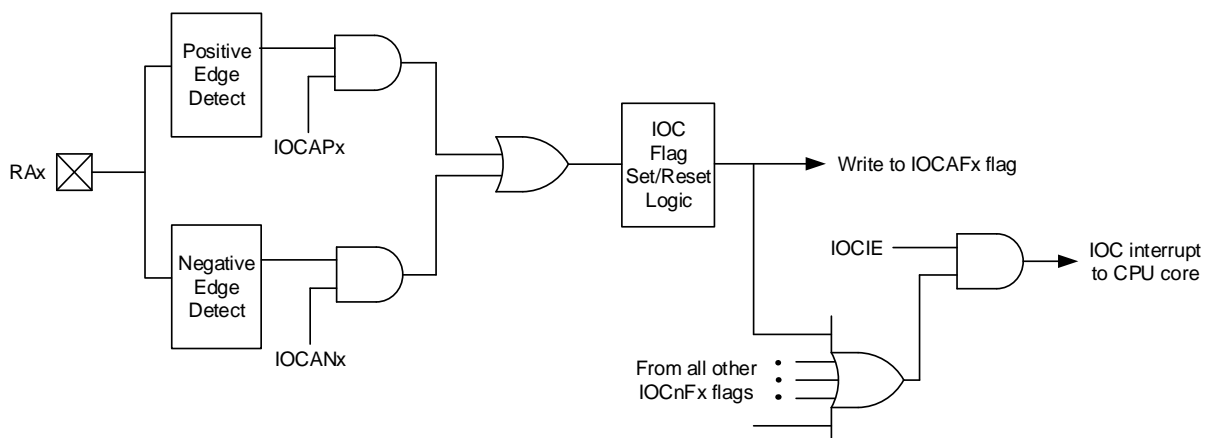

17.2 Enabling the Module

For individual PORT pins to generate an interrupt, the IOC Interrupt Enable (IOCIE) bit of the Peripheral Interrupt Enable (PIEx) register must be set. If the IOC Interrupt Enable bit is disabled, the edge detection on the pin will still occur, but an interrupt will not be generated.

17.3 Individual Pin Configuration

A rising edge detector and a falling edge detector are present for each PORT pin. To enable a pin to detect a rising edge, the associated bit of the IOCxP register must be set. To enable a pin to detect a falling edge, the associated bit of the IOCxN register must be set. A PORT pin can be configured

to detect rising and falling edges simultaneously by setting both associated bits of the IOCxP and IOCxN registers, respectively.

17.4 Interrupt Flags

The bits located in the IOCxF registers are status flags that correspond to the interrupt-on-change pins of each port. If an expected edge is detected on an appropriately enabled pin, then the status flag for that pin will be set, and an interrupt will be generated if the IOCIE bit is set. The IOCIF bit located in the corresponding Peripheral Interrupt Request (PIRx) register, is all the IOCxF bits OR'd together. The IOCIF bit is read-only. All of the IOCxF Status bits must be cleared to clear the IOCIF bit.

17.5 Clearing Interrupt Flags

The individual status flags (IOCxF register bits) will be cleared by resetting them to zero. If another edge is detected during this clearing operation, the associated status flag will be set at the end of the sequence, regardless of the value actually being written.

To ensure that no detected edge is lost while clearing flags, only AND operations masking out known changed bits must be performed. The following sequence is an example of clearing an IOC interrupt flag using this method.

Example 17-1. Clearing Interrupt Flags (PORTA Example)

```
MOVLW    0xff
XORWF    IOCAF, W
ANDWF    IOCAF, F
```

17.6 Operation in Sleep

An interrupt-on-change event will wake the device from Sleep mode, if the IOCIE bit is set. If an edge is detected while in Sleep mode, the IOCxF register will be updated prior to the first instruction executed out of Sleep.

17.7 Register Definitions: Interrupt-on-Change Control

17.7.1 IOCF

Name: IOCF

Interrupt-on-Change Flag Register

Bit	7	6	5	4	3	2	1	0
	IOCF7	IOCF6	IOCF5	IOCF4	IOCF3	IOCF2	IOCF1	IOCF0
Access	R/W/HS	R/W/HS	R/W/HS	R/W/HS	R/W/HS	R/W/HS	R/W/HS	R/W/HS
Reset	0	0	0	0	0	0	0	0

Bits 0, 1, 2, 3, 4, 5, 6, 7 - IOCFn Interrupt-on-Change Flag

Value	Condition	Description
1	IOCP[n] = 1	A positive edge was detected on the Rx[n] pin
1	IOCN[n] = 1	A negative edge was detected on the Rx[n] pin
0	IOCP[n] = x and IOCN[n] = x	No change was detected, or the user cleared the detected change



Important:

- If MCLRE = 1 or LVP = 1, the $\overline{\text{MCLR}}$ pin port functionality is disabled and IOC on that pin is not available
- Refer to the “**Pin Allocation Table**” for details about pins with configurable IOC per port

17.7.2 IOCxN

Name: IOCxN

Interrupt-on-Change Negative Edge Register Example

Bit	7	6	5	4	3	2	1	0
	IOCxN7	IOCxN6	IOCxN5	IOCxN4	IOCxN3	IOCxN2	IOCxN1	IOCxN0
Access	R/W	R/W	R/W	R/W	R/W	R/W	R/W	R/W
Reset	0	0	0	0	0	0	0	0

Bits 0, 1, 2, 3, 4, 5, 6, 7 – IOCxNn Interrupt-on-Change Negative Edge Enable

Value	Description
1	Interrupt-on-change enabled on the IOCx pin for a negative-going edge. Associated Status bit and interrupt flag will be set upon detecting an edge.
0	Falling edge interrupt-on-change disabled for the associated pin



Important:

- If MCLRE = 1 or LVP = 1, the $\overline{\text{MCLR}}$ pin port functionality is disabled and IOC on that pin is not available
- Refer to the **“Pin Allocation Table”** for details about pins with configurable IOC per port

17.7.3 IOCP

Name: IOCP

Interrupt-on-Change Positive Edge Register

Bit	7	6	5	4	3	2	1	0
	IOCP7	IOCP6	IOCP5	IOCP4	IOCP3	IOCP2	IOCP1	IOCP0
Access	R/W	R/W	R/W	R/W	R/W	R/W	R/W	R/W
Reset	0	0	0	0	0	0	0	0

Bits 0, 1, 2, 3, 4, 5, 6, 7 – IOCPn Interrupt-on-Change Positive Edge Enable

Value	Description
1	Interrupt-on-change enabled on the IOCP pin for a positive-going edge. Associated Status bit and interrupt flag will be set upon detecting an edge.
0	Rising edge interrupt-on-change disabled for the associated pin.



Important:

- If MCLRE = 1 or LVP = 1, the $\overline{\text{MCLR}}$ pin port functionality is disabled and IOC on that pin is not available
- Refer to the **“Pin Allocation Table”** for details about pins with configurable IOC per port

17.8 Register Summary - Interrupt-on-Change

Offset	Name	Bit Pos.	7	6	5	4	3	2	1	0
0x00 ...	Reserved									
0x1E90										
0x1E91	IOCAP	7:0			IOCAP5	IOCAP4	IOCAP3	IOCAP2	IOCAP1	IOCAP0
0x1E92	IOCAN	7:0			IOCAN5	IOCAN4	IOCAN3	IOCAN2	IOCAN1	IOCAN0
0x1E93	IOCAF	7:0			IOCAF5	IOCAF4	IOCAF3	IOCAF2	IOCAF1	IOCAF0
0x1E94 ...	Reserved									
0x1E9A										
0x1E9B	IOCBP	7:0	IOCBP7	IOCBP6	IOCBP5	IOCBP4				
0x1E9C	IOCBN	7:0	IOCBN7	IOCBN6	IOCBN5	IOCBN4				
0x1E9D	IOCBF	7:0	IOCBF7	IOCBF6	IOCBF5	IOCBF4				
0x1E9E ...	Reserved									
0x1EA4										
0x1EA5	IOCCP	7:0	IOCCP7	IOCCP6	IOCCP5	IOCCP4	IOCCP3	IOCCP2	IOCCP1	IOCCP0
0x1EA6	IOCCN	7:0	IOCCN7	IOCCN6	IOCCN5	IOCCN4	IOCCN3	IOCCN2	IOCCN1	IOCCN0
0x1EA7	IOCCF	7:0	IOCCF7	IOCCF6	IOCCF5	IOCCF4	IOCCF3	IOCCF2	IOCCF1	IOCCF0

18. PPS - Peripheral Pin Select Module

18.1 Overview

The Peripheral Pin Select (PPS) module connects peripheral inputs and outputs to the device I/O pins. Only digital signals are included in the selections.



Important: All analog inputs and outputs remain fixed to their assigned pins and cannot be changed through PPS.

Input and output selections are independent as shown in the figure below.

Figure 18-1. PPS Block Diagram

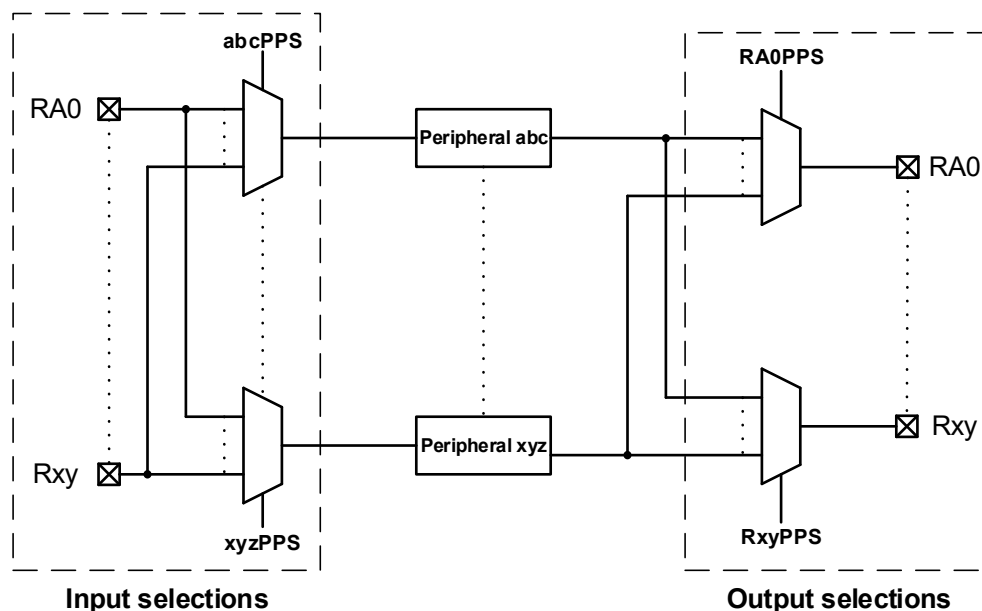

18.2 PPS Inputs

Each digital peripheral has a dedicated PPS Peripheral Input Selection ($xxxPPS$) register with which the input pin to the peripheral is selected. Devices that have 20 leads or less (8/14/16/20) allow PPS routing to any I/O pin, while devices with 28 leads or more allow PPS routing to I/Os contained within two ports (see the table below).



Important: The notation “xxx” in the generic register name is a placeholder for the peripheral identifier. For example, xxx = T0CKI for the T0CKIPPS register.

Multiple peripherals can operate from the same source simultaneously. Port reads always return the pin level regardless of peripheral PPS selection. If a pin also has analog functions associated, the ANSEL bit for that pin must be cleared to enable the digital input buffer.

Table 18-1. PPS Input Selection Table

Peripheral	PPS Input Register	Register Reset Value at POR		Default Pin Selection at POR	
		14/16-Pin Devices	20-Pin Devices	14/16-Pin Devices	20-Pin Devices
External Interrupt	INTPPS	`b000 010		RA2	
Timer0 Clock	T0CKIPPS	`b000 010		RA2	
Timer1 Clock	T1CKIPPS	`b000 101		RA5	
Timer1 Gate	T1GPPS	`b000 100		RA4	
Timer3 Clock	T3CKIPPS	`b010 101		RC5	
Timer3 Gate	T3GPPS	`b010 100		RC4	
Timer2 Input	T2INPPS	`b000 101		RA5	
Timer4 Input	T4INPPS	`b010 001		RC1	
CCP1	CCP1PPS	`b010 101		RC5	
CCP2	CCP2PPS	`b010 011		RC3	
PWM Input 0	PWMIN0PPS	`b010 101		RC5	
PWM Input 1	PWMIN1PPS	`b010 011		RC3	
PWM1 External Reset	PWMIN1ERSPPS	`b000 101		RA5	
PWM2 External Reset	PWMIN2ERSPPS	`b010 001		RC1	
CWG1 Input	CWG1PPS	`b000 010		RA2	
CLCIN0	CLCIN0PPS	`b010 011	`b000 010	RC3	RA2
CLCIN1	CLCIN1PPS	`b010 100	`b010 011	RC4	RC3
CLCIN2	CLCIN2PPS	`b010 001	`b001 100	RC1	RB4
CLCIN3	CLCIN3PPS	`b000 101	`b001 101	RA5	RB5
SCL1/SCK1	SSP1CLKPPS ⁽¹⁾	`b010 000	`b001 110	RC0	RB6
SDA1/SDI1	SSP1DATPPS ⁽¹⁾	`b010 001	`b001 100	RC1	RB4
SS1	SSP1SSPPS	`b010 011	`b010 110	RC3	RC6
SCL2/SCK2	SSP2CLKPPS ⁽¹⁾	`b010 100	`b001 111	RC4	RB7
SDA2/SDI2	SSP2DATPPS ⁽¹⁾	`b010 101	`b001 101	RC5	RB5
SS2	SSP2SSPPS	`b000 000	`b000 001	RA0	RA1
RX1/DT1	RX1PPS	`b010 101	`b001 101	RC5	RB5
CK1	CK1PPS	`b010 100	`b001 111	RC4	RB7
RX2/DT2	RX2PPS	`b010 001		RC1	
CK2	CK2PPS	`b010 000		RC0	
ADC Conversion Trigger	ADACTPPS	`b010 010		RC2	

Note:

1. Bidirectional pin. The corresponding output must select the same pin.

18.3 PPS Outputs

Each digital peripheral has a dedicated Pin Rxy Output Source Selection (**RxyPPS**) register with which the pin output source is selected. With few exceptions, the port TRIS control associated with that pin retains control over the pin output driver. Peripherals that control the pin output driver as part of the peripheral operation will override the TRIS control as needed. The I²C module is an example of such a peripheral.



Important: The notation 'Rxy' is a placeholder for the pin identifier. The 'x' holds the place of the PORT letter and the 'y' holds the place of the bit number. For example, Rxy = RA0 for the RA0PPS register.

The table below shows the output codes for each peripheral, as well as the available Port selections.

Table 18-2. PPS Output Selection Table

RxyPPS	Output Source
0x23	ADGRDB
0x22	ADGRDA
0x21	CLKR
0x20	NCO1
0x1F	TMR0
0x1E	SDA2/SDO2 ⁽¹⁾
0x1D	SCL2/SCK2 ⁽¹⁾
0x1C	SDA1/SDO1 ⁽¹⁾
0x1B	SCL1/SCK1 ⁽¹⁾
0x1A	C2_OUT
0x19	C1_OUT
0x18	DT2
0x17	Reserved
0x16	TX2/CK2
0x15	DT1
0x14	Reserved
0x13	TX1/CK1
0x12	Reserved
0x11	Reserved
0x10	Reserved
0x0F	Reserved
0x0E	PWM2S1P2_OUT
0x0D	PWM2S1P1_OUT
0x0C	PWM1S1P2_OUT
0x0B	PWM1S1P1_OUT
0x0A	CCP2
0x09	CCP1
0x08	CWG1D
0x07	CWG1C
0x06	CWG1B
0x05	CWG1A
0x04	CLC4_OUT
0x03	CLC3_OUT
0x02	CLC2_OUT
0x01	CLC1_OUT
0x00	LATxy

Note:

1. Bidirectional pin. The corresponding input must select the same pin.

18.4 Bidirectional Pins

PPS selections for peripherals with bidirectional signals on a single pin must be made so that the PPS input and PPS output select the same pin. The I²C Serial Clock (SCL) and Serial Data (SDA) are examples of such pins.



Important: The I²C default pins and a limited number of other alternate pins are I²C and SMBus compatible. SDA and SCL signals can be routed to any pin; however, pins without I²C compatibility will operate at standard TTL/ST logic levels as selected by the port's INLVL register.

18.5 PPS Lock

The PPS module provides an extra layer of protection to prevent inadvertent changes to the PPS selection registers. The **PPSLOCKED** bit is used in combination with specific code execution blocks to lock/unlock the PPS selection registers.



Important: The PPSLOCKED bit is clear by default (PPSLOCKED = 0), which allows the PPS selection registers to be modified without an unlock sequence.

PPS selection registers are locked when the PPSLOCKED bit is set (PPSLOCKED = 1). Setting the PPSLOCKED bit requires a specific lock sequence as shown in the examples below in both C and assembly languages.

PPS selection registers are unlocked when the PPSLOCKED bit is clear (PPSLOCKED = 0). Clearing the PPSLOCKED bit requires a specific unlock sequence as shown in the examples below in both C and assembly languages.



Important: All interrupts must be disabled before starting the lock/unlock sequence to ensure proper execution.

Example 18-1. PPS Lock Sequence (assembly language)

```
; suspend interrupts
BCF     INTCON0,GIE
BANKSEL PPSLOCK
; required sequence, next 5 instructions
MOVLW  0x55
MOVWF  PPSLOCK
MOVLW  0xAA
MOVWF  PPSLOCK
; Set PPSLOCKED bit
BSF     PPSLOCK,PPSLOCKED
; restore interrupts
BSF     INTCON0,GIE
```

Example 18-2. PPS Lock Sequence (C language)

```
INTCON0bits.GIE = 0;           //Suspend interrupts
PPSLOCK = 0x55;                //Required sequence
PPSLOCK = 0xAA;                //Required sequence
PPSLOCKbits.PPSLOCKED = 1;    //Set PPSLOCKED bit
INTCON0bits.GIE = 1;           //Restore interrupts
```

Example 18-3. PPS Unlock Sequence (assembly language)

```
; suspend interrupts
BCF     INTCON0,GIE
```

```

    BANKSEL  PPSLOCK
; required sequence, next 5 instructions
    MOVLW   0x55
    MOVWF  PPSLOCK
    MOVLW   0xAA
    MOVWF  PPSLOCK
; Clear PPSLOCKED bit
    BCF    PPSLOCK, PPSLOCKED
; restore interrupts
    BSF    INTCON0, GIE

```

Example 18-4. PPS Unlock Sequence (C language)

```

INTCON0bits.GIE = 0;           //Suspend interrupts
PPSLOCK = 0x55;               //Required sequence
PPSLOCK = 0xAA;               //Required sequence
PPSLOCKbits.PPSLOCKED = 0;    //Clear PPSLOCKED bit
INTCON0bits.GIE = 1;         //Restore interrupts

```

18.5.1 PPS One-Way Lock

The PPS1WAY Configuration bit can also be used to prevent inadvertent modification to the PPS selection registers.

When the PPS1WAY bit is set (PPS1WAY = 1), the **PPSLOCKED** bit can only be set one time after a device Reset. Once the PPSLOCKED bit has been set, it cannot be cleared again unless a device Reset is executed.

When the PPS1WAY bit is clear (PPS1WAY = 0), the PPSLOCKED bit can be set or cleared as needed; however, the PPS lock/unlock sequences must be executed.

18.6 Operation During Sleep

PPS input and output selections are unaffected by Sleep.

18.7 Effects of a Reset

A device Power-on Reset (POR) or Brown-out Reset (BOR) returns all PPS input selection registers to their default values and clears all PPS output selection registers. All other Resets leave the selections unchanged. Default input selections are shown in the PPS input register details table. The **PPSLOCKED** bit is cleared in all Reset conditions.

18.8 Register Definitions: Peripheral Pin Select (PPS)

18.8.1 xxxPPS**Name:** xxxPPS

Peripheral Input Selection Register

Bit	7	6	5	4	3	2	1	0
			PORT[2:0]			PIN[2:0]		
Access			R/W	R/W	R/W	R/W	R/W	R/W
Reset			m	m	m	m	m	m

Bits 5:3 – PORT[2:0] Peripheral Input PORT Selection⁽¹⁾See the [PPS Input Selection Table](#) for the list of available Ports and default pin locations.

PORT	Selection
010	PORTC
001	PORTB
000	PORTA

Reset States: POR = mmm

All other Resets = uuu

Bits 2:0 – PIN[2:0] Peripheral Input PORT Pin Selection⁽²⁾

Reset States: POR = mmm

All other Resets = uuu

Value	Description
111	Peripheral input is from PORTx Pin 7 (Rx7)
110	Peripheral input is from PORTx Pin 6 (Rx6)
101	Peripheral input is from PORTx Pin 5 (Rx5)
100	Peripheral input is from PORTx Pin 4 (Rx4)
011	Peripheral input is from PORTx Pin 3 (Rx3)
010	Peripheral input is from PORTx Pin 2 (Rx2)
001	Peripheral input is from PORTx Pin 1 (Rx1)
000	Peripheral input is from PORTx Pin 0 (Rx0)

Notes:

1. The Reset value 'm' is determined by device default locations for that input.
2. Refer to the **"Pin Allocation Table"** for details about available pins per port.

18.8.2 RxyPPS

Name: RxyPPS

Pin Rxy Output Source Selection Register

Bit	7	6	5	4	3	2	1	0
			RxyPPS[5:0]					
Access			R/W	R/W	R/W	R/W	R/W	R/W
Reset			0	0	0	0	0	0

Bits 5:0 – RxyPPS[5:0] Pin Rxy Output Source Selection

See the [PPS Output Selection Table](#) for the list of RxyPPS Output Source codes

Reset States: POR = 000000

All other Resets = uuuuuu

18.8.3 PPSLOCK

Name: PPSLOCK

PPS Lock Register

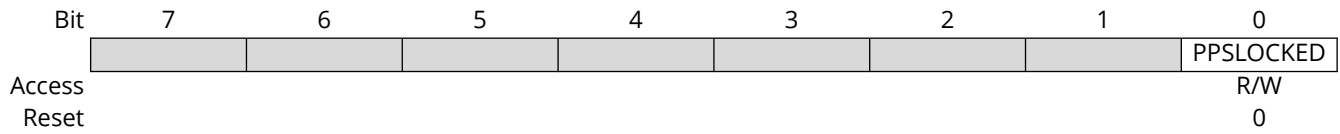

Bit 0 - PPSLOCKED PPS Locked

Reset States: POR = 0

All other Resets = 0

Value	Description
1	PPS is locked. PPS selections cannot be changed. Writes to any PPS register are ignored.
0	PPS is not locked. PPS selections can be changed, but may require the PPS lock/unlock sequence.

18.9 Register Summary - Peripheral Pin Select Module

Offset	Name	Bit Pos.	7	6	5	4	3	2	1	0
0x00	Reserved									
...										
0x1D8B	Reserved									
0x1D8C	RA0PPS	7:0						RA0PPS[5:0]		
0x1D8D	RA1PPS	7:0						RA1PPS[5:0]		
0x1D8E	RA2PPS	7:0						RA2PPS[5:0]		
0x1D8F	Reserved									
0x1D90	RA4PPS	7:0						RA4PPS[5:0]		
0x1D91	RA5PPS	7:0						RA5PPS[5:0]		
0x1D92	Reserved									
...										
0x1D97	Reserved									
0x1D98	RB4PPS	7:0						RB4PPS[5:0]		
0x1D99	RB5PPS	7:0						RB5PPS[5:0]		
0x1D9A	RB6PPS	7:0						RB6PPS[5:0]		
0x1D9B	RB7PPS	7:0						RB7PPS[5:0]		
0x1D9C	RC0PPS	7:0						RC0PPS[5:0]		
0x1D9D	RC1PPS	7:0						RC1PPS[5:0]		
0x1D9E	RC2PPS	7:0						RC2PPS[5:0]		
0x1D9F	RC3PPS	7:0						RC3PPS[5:0]		
0x1DA0	RC4PPS	7:0						RC4PPS[5:0]		
0x1DA1	RC5PPS	7:0						RC5PPS[5:0]		
0x1DA2	RC6PPS	7:0						RC6PPS[5:0]		
0x1DA3	RC7PPS	7:0						RC7PPS[5:0]		
0x1DA4	Reserved									
...										
0x1E0B	Reserved									
0x1E0C	PPSLOCK	7:0								PPSLOCKED
0x1E0D	INTPPS	7:0				PORT[2:0]			PIN[2:0]	
0x1E0E	T0CKIPPS	7:0				PORT[2:0]			PIN[2:0]	
0x1E0F	T1CKIPPS	7:0				PORT[2:0]			PIN[2:0]	
0x1E10	T1GPPS	7:0				PORT[2:0]			PIN[2:0]	
0x1E11	T3CKIPPS	7:0				PORT[2:0]			PIN[2:0]	
0x1E12	T3GPPS	7:0				PORT[2:0]			PIN[2:0]	
0x1E13	Reserved									
...										
0x1E18	Reserved									
0x1E19	T2INPPS	7:0				PORT[2:0]			PIN[2:0]	
0x1E1A	T4INPPS	7:0				PORT[2:0]			PIN[2:0]	
0x1E1B	Reserved									
...										
0x1E1D	Reserved									
0x1E1E	CCP1PPS	7:0				PORT[2:0]			PIN[2:0]	
0x1E1F	CCP2PPS	7:0				PORT[2:0]			PIN[2:0]	
0x1E20	Reserved									
...										
0x1E23	Reserved									
0x1E24	PWMIN0PPS	7:0				PORT[2:0]			PIN[2:0]	
0x1E25	PWMIN1PPS	7:0				PORT[2:0]			PIN[2:0]	
0x1E26	PWM1ERSPPS	7:0				PORT[2:0]			PIN[2:0]	
0x1E27	PWM2ERSPPS	7:0				PORT[2:0]			PIN[2:0]	
0x1E28	Reserved									
...										
0x1E38	Reserved									
0x1E39	CWG1PPS	7:0				PORT[2:0]			PIN[2:0]	
0x1E3A	Reserved									
...										
0x1E3C	Reserved									
0x1E3D	CLCIN0PPS	7:0				PORT[2:0]			PIN[2:0]	
0x1E3E	CLCIN1PPS	7:0				PORT[2:0]			PIN[2:0]	

.....continued

Offset	Name	Bit Pos.	7	6	5	4	3	2	1	0
0x1E3F	CLCIN2PPS	7:0				PORT[2:0]			PIN[2:0]	
0x1E40	CLCIN3PPS	7:0				PORT[2:0]			PIN[2:0]	
0x1E41	CK1PPS	7:0				PORT[2:0]			PIN[2:0]	
0x1E42	RX1PPS	7:0				PORT[2:0]			PIN[2:0]	
0x1E43	CK2PPS	7:0				PORT[2:0]			PIN[2:0]	
0x1E44	RX2PPS	7:0				PORT[2:0]			PIN[2:0]	
0x1E45	Reserved									
...										
0x1E46										
0x1E47	SSP1CLKPPS	7:0				PORT[2:0]			PIN[2:0]	
0x1E48	SSP1DATPPS	7:0				PORT[2:0]			PIN[2:0]	
0x1E49	SSP1SSPPS	7:0				PORT[2:0]			PIN[2:0]	
0x1E4A	SSP2CLKPPS	7:0				PORT[2:0]			PIN[2:0]	
0x1E4B	SSP2DATPPS	7:0				PORT[2:0]			PIN[2:0]	
0x1E4C	SSP2SSPPS	7:0				PORT[2:0]			PIN[2:0]	
0x1E4D	Reserved									
...										
0x1E4F										
0x1E50	ADACTPPS	7:0				PORT[2:0]			PIN[2:0]	

19. CRC - Cyclic Redundancy Check Module with Memory Scanner

The Cyclic Redundancy Check (CRC) module provides a software-configurable hardware-implemented CRC checksum generator. This module includes the following features:

- Any standard CRC up to 32 bits can be used
- Configurable polynomial
- Any seed value up to 32 bits can be used
- Standard and reversed bit order available
- Augmented zeros can be added automatically or by the user
- Memory scanner for core-independent CRC calculations on any program memory locations
- Software configurable data registers for communication CRCs

19.1 Module Overview

The CRC module is coupled with a memory scanner that provides a means of performing CRC calculations in hardware, without CPU intervention. The memory scanner can automatically provide data from program Flash memory to the CRC module. The CRC module can also be operated by directly writing data to SFRs, without using a scanner.

The CRC module can be used to detect bit errors in the Flash memory using the built-in memory scanner or through user input RAM. The CRC module can accept up to a 32-bit polynomial with up to a 32-bit seed value. A CRC calculated check value (or checksum) will then be generated into the **CRCOUT** registers for user storage. The CRC module uses an XOR shift register implementation to perform the polynomial division required for the CRC calculation. This feature is useful for calculating CRC values of data being transmitted or received using communications peripherals such as the SPI, UART or I²C.

19.2 Polynomial Implementation

The CRC polynomial equation is user configurable, allowing any polynomial equation to be used for the CRC checksum calculation. The polynomial and accumulator sizes are determined by the **PLEN** bits. For an n-bit accumulator, PLEN = n-1 and the corresponding polynomial is n+1 bits. This allows the accumulator to be any size up to 32 bits with a corresponding polynomial up to 33 bits. The MSb and LSb of the polynomial are always '1' which is forced by hardware. Therefore, the LSb of the **CRCXOR** Low Byte register is hardwired high and always reads as '1'.

All polynomial bits between the MSb and LSb are specified by the **CRCXOR** registers.

For example, when using the standard CRC32, the polynomial is defined as $0x4C11DB7$

($x^{32} + x^{26} + x^{23} + x^{22} + x^{16} + x^{12} + x^{11} + x^{10} + x^8 + x^7 + x^5 + x^4 + x^2 + x + 1$). In this polynomial, the X^{32} and X^0 terms are the MSb and LSb controlled by hardware. The X^{31} and X^1 terms are specified by setting the **CRCXOR**[31:0] bits with the corresponding polynomial value, which in this example is $0x04C11DB6$. Reading the **CRCXOR** registers will return $0x04C11DB7$ because the LSb is always '1'.

Refer to the following example for more details.

Example 19-1. CRC32 Example

Standard CRC32 Polynomial (33 bits):

$$(x^{32} + x^{26} + x^{23} + x^{22} + x^{16} + x^{12} + x^{11} + x^{10} + x^8 + x^7 + x^5 + x^4 + x^2 + x + 1)$$

Standard 32-bit Polynomial Representation: $0x04C11DB7$

CRCXORT = $0x04$ = $0b00000100$

CRCXORU = $0xC1$ = $0b11000001$

CRCXORH = $0x1D$ = $0b00011101$

```

CRCXORL = 0xB7 = 0b1011011- (1)

Data Sequence: 0x55, 0x66, 0x77, 0x88

DLEN = 0b00111 // Number of bits written to CRCDATA registers
(Data Length)

PLEN = 0b11111 // MSb position of the polynomial (Polynomial
Length)

Data Passed into the CRC:

// SHIFTM = 0 (Shift Mode: MSb first)
0x55 0x66 0x77 0x88 = 01010101 01100110 01110111 10001000

// SHIFTM = 1 (Shift Mode: LSb first)
0x55 0x66 0x77 0x88 = 10101010 01100110 11101110 00010001

CRC Check Value (ACCM = 1, data are augmented with zeros)

// When SHIFTM = 0, CRC Result = 0xC60D8323
CRCOUTT = 0xC6 = 0b11000110
CRCOUTU = 0x0D = 0b00001101
CRCOUTH = 0x83 = 0b10000011
CRCOUTL = 0x23 = 0b00100011

// When SHIFTM = 1, CRC Result = 0x843529CC
CRCOUTT = 0x84 = 0b10000100
CRCOUTU = 0x35 = 0b00110101
CRCOUTH = 0x29 = 0b00101001
CRCOUTL = 0xCC = 0b11001100

Note:
1. Bit 0 is unimplemented. The LSb of any CRC polynomial is always '1' and will
always be treated as a '1' by the CRC for calculating the CRC check value. This bit
will be read in software as a '0'.

```

19.3 Data Sources

Data are supplied to the CRC module using the [CRCDATA](#) registers and can either be loaded manually or automatically by using the scanner module. The length of the data word being supplied to the CRC module is specified by the [DLEN](#) bits and can be configured for data words up to 32 bits in length. The DLEN field indicates how many bits in the CRCDATA registers are valid and any bits outside of the specified data word size will be ignored. Data are moved into the [CRCSHIFT](#) registers as an intermediate to calculate the check value located in the [CRCOUT](#) registers. The [SHIFTM](#) bit is used to determine the bit order of the data being shifted into the accumulator and the bit order of the result.

Figure 19-1. CRC Process

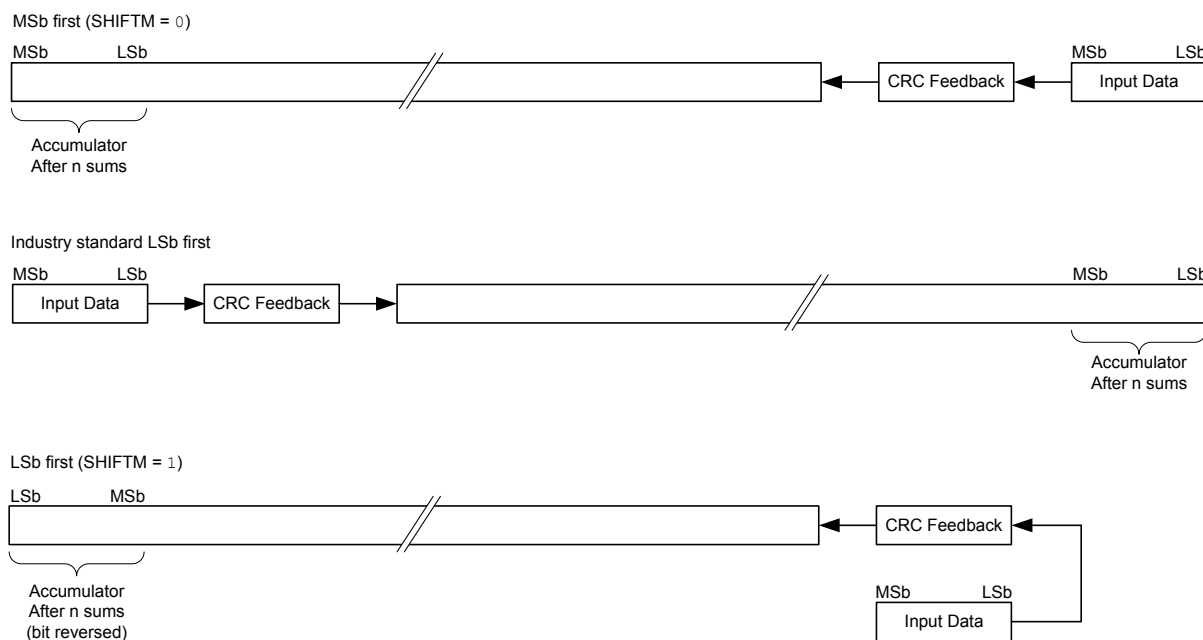

When the SHIFTM bit is not set, data will be shifted into the CRC, MSb first and the result will be big-endian. When the SHIFTM bit is set, data will be shifted into the accumulator in the reverse order (LSb first) and the result will be little-endian. The CRC module can be seeded with an initial value by setting the CRCOUT registers to the appropriate value before beginning the CRC process.

19.3.1 CRC from User Data

Data can be supplied to the CRC module by writing to the CRCDATA registers. Once data has been loaded into the CRCDATA registers, it will then be latched onto the CRC Shift (CRCSHIFT) registers. If data are still being shifted from an earlier write to the CRCDATA registers and the user attempts to write more data, the most recently written data will be held in the CRCDATA registers until the previous shift has completed.

19.3.2 CRC from Flash

Data can also be supplied to the CRC module using the memory scanner, as opposed to writing the data manually using the CRCDATA registers, allowing users to automate CRC calculations. An automated scan of Program Flash Memory or Data EEPROM can be performed by configuring the scanner accordingly to copy data into the CRCDATA registers. The user can initialize the program memory scanner as defined in the **“Scanner Module Overview”** and **“Configuring the Scanner”** sections.

19.4 CRC Check Value

The CRC check value can be accessed using the CRCOUT registers after a CRC calculation has completed. The check value is dependent on the configuration of the ACCM and SHIFTM mode settings. When the ACCM bit is set, the CRC module will augment the data with a number of zeros equal to the length of the polynomial to align the final check value. When the ACCM bit is not set, the CRC will stop at the end of the data and no additional zeroes will be augmented to the final value. The user can manually augment a number of additional zeroes equal to the length of the polynomial by entering them into the CRCDATA register, which will yield the same check value as Augmented mode. Alternatively, the expected check value can be entered at this point to make the final result equal zero.

When the CRC check value is computed with the SHIFTM (LSb first) and ACCM bits set, the final value in the CRCOUT registers will be reversed such that the LSb will be in the MSb position and vice versa (Figure 19-1).

When creating a check value to be appended to a data stream, then a reversal must be performed on the final value to achieve the correct checksum. The CRC can be used to do this reversal by following the steps below.

1. Save CRCOUT value in user RAM space.
2. Clear the CRCOUT registers.
3. Clear the CRCXOR registers.
4. Write the saved CRCOUT value to the CRCDATA input.

If the steps listed above were followed completely, the properly orientated check value will be in the CRCOUT registers.

19.5 CRC Interrupt

The CRC module will generate an interrupt when the BUSY bit transitions from '1' to '0'. The CRC Interrupt Flag (CRCIF) bit of the corresponding PIR register will be set every time the BUSY bit transitions, whether or not the CRC Interrupt Enable (CRCIE) has been set. The CRCIF bit must be cleared by software by the user. If the user has the CRCIE bit set, then the CPU will jump to the Interrupt Service Routine (ISR) every time that the CRCIF bit is set.

19.6 Configuring the CRC Module

The following steps illustrate how to properly configure the CRC:

1. Determine if the automatic program memory scan will be used with the scanner or manual calculation through the SFR interface and perform the actions specified in the CRC Data Sources section.
 - a. To configure the scanner module to be used with CRC, refer to the **"Configuring the Scanner"** section for more information.
2. When applicable, seed a starting CRC value into the CRCOUT registers.
3. Program the CRCXOR registers with the desired generator polynomial.
4. Program the DLEN bits with the length of the data word (refer to Figure 19-1). This value determines how many times the shifter will shift into the accumulator for each data word.
5. Program the PLEN bits with the length of the polynomial (refer to Figure 19-1).
6. Determine whether shifting in trailing zeroes is desired and set the ACCM bit accordingly.
7. Determine whether the MSb or LSb first shifting is desired, and write the SHIFTM bit accordingly.
8. Set the GO bit to begin the shifting process.
9. If manual SFR entry is used, monitor the FULL bit.
 - a. When FULL = 0, another word of data can be written to the CRCDATA registers. It is important to note that the Most Significant Byte (CRCDATAH) must be written first if the data has more than eight bits, as the shifter will begin upon the CRCDATAL register being written.
 - b. If the scanner is used, the scanner will automatically load words into the CRCDATA registers as needed, as long as the GO bit is set.
10. If using the Flash memory scanner, monitor the SCANIF bit of the corresponding PIR register to determine when the scanner has finished pushing data into the CRCDATA registers.
 - a. After the scan is completed, monitor the SGO bit to determine that the CRC has been completed and the check value can be read from the CRCOUT registers.
 - b. When both the interrupt flags are set (or both BUSY and SGO bits are cleared), the completed CRC calculation can be read from the CRCOUT registers.

11. If manual entry is used, monitor the BUSY bit to determine when the CRCOUT registers hold the valid check value.

19.6.1 Register Overlay

The [CRCOUT](#), [CRCSHIFT](#) and [CRCXOR](#) registers are grouped together and share SFR space. Since these register groups are located within the same addresses, the [SETUP](#) bits must be configured accordingly to access any of these registers. Refer to the [CRCCON2](#) register for more information about how the SETUP bits can be configured to access each of the available CRC registers.

19.7 Scanner Module Overview

The scanner allows segments of the Program Flash Memory or Data EEPROM to be read out (scanned) to the CRC peripheral. The scanner module interacts with the CRC module and supplies it data, one word at a time. Data are fetched from the address range defined by [SCANLADR](#) registers up to the [SCANHADR](#) registers. The scanner begins operation when the [SGO](#) bit is set and ends when either SGO is cleared by the user or when SCANLADR increments past SCANHADR. The SGO bit is also cleared when the [EN](#) bit in the [CRCCON0](#) register is cleared.



Important: When using the scanner module in conjunction with the CRC module, the [CRCEN](#) and [CRCGO](#) bits must be set before setting the [SGO](#) bit.

19.8 Scanning Modes

The interaction of the scanner with system operation is determined by the Scanner Memory Access Mode Select ([MD](#)) bits. The MD bits also determine the operation of the scanner.

The following modes are determined by the MD bits:

- Concurrent mode
- Burst mode
- Peek mode
- Triggered mode

19.8.1 Concurrent Mode

In Concurrent mode, the scanner will access memory on the instruction cycle following the instruction that sets [SGO](#). During memory access, the CPU is stalled. Once the memory location has been accessed, the CPU resumes normal operation until the scanner is ready to access the next location.

19.8.2 Burst Mode

Burst mode provides the highest scan throughput of all modes. CPU operation is stalled on the instruction following the instruction that sets [SGO](#) and remains stalled until the last NVM location has been transferred. Once hardware clears [SGO](#), the CPU resumes normal operation.



Important: In Burst mode, software cannot clear [SGO](#) while the scan is in progress since the CPU cannot execute instructions while stalled.

19.8.3 Peek Mode

Peek mode provides the least impact on CPU operation. In Peek mode, the scanner waits until the CPU does not need to access the NVM and 'steals' the instruction cycle to perform a scan. Program branching ([GOTO](#), [BRA](#), [BRW](#)), subroutine entry ([CALL](#), [CALLW](#)), or returns from interrupts or

subroutines (`RETURN`, `RETFIE`, `RETLW`) operations take two instruction cycles but do not access NVM, so the scanner may use one of those instruction cycles for scanning operations.

While Peek mode may have the least impact on CPU operation, the time required to complete the scan will vary depending on which instructions the CPU is executing.

19.8.4 Triggered Mode

Triggered mode uses a clock or timer source to set a minimum time interval between successive data transfers. The trigger source is selected through the Scanner Data Trigger Input Selection (`TSEL`) bits. Triggered mode operation is the same as in Concurrent mode, except that the scanner will wait until it detects a rising-edge trigger event before performing a scan operation. The CPU operations are stalled while the scan is in progress and resume immediately after the scan completes. If the Scanner Busy Indicator (`BUSY`) bit is set and a trigger event occurs, the event will be ignored.

Note: The trigger source must be active for scanner operation to complete.

19.9 Configuring the Scanner

The scanner module may be used in conjunction with the CRC module to perform a CRC calculation over a range of program memory or Data EEPROM addresses. To set up the scanner to work with the CRC, perform the following steps:

1. Set up the CRC module (see the “**Configuring the CRC Module**” section) and enable the scanner module by setting the `EN` bit in the `SCANCON0` register.
2. Choose the scanning mode by configuring the `MD` bits.
3. If Trigger mode is selected for scanner operation, select the trigger source using the `TSEL` bits.
4. Set the `SCANLADR` and `SCANHADR` registers with the beginning and ending locations in memory that are to be scanned.
5. Both `EN` and `GO` bits in the `CRCCON0` register must be enabled to use the scanner. Setting the `SGO` bit will start the scanner operation.

19.10 Scanner Interrupts

Scanner hardware will generate an interrupt when any of the following events occur:

- The last memory location (as determined by the `SCANHADR` registers) has been read and the data loaded into the `CRCDATA` registers
- The `SCANLADR` register pair points to an invalid address location
- The `CRCGO` and/or `CRCEN` bits are cleared

When the last memory location has been scanned and the data has been entered into the `CRCDATA` registers, scanner hardware clears `SGO` and sets the Scanner Interrupt Flag (`SCANIF`) bit in the `PIR` registers.

If the `SCANLADR` registers point to an invalid address location, or the `CRCGO` and/or `CRCEN` bits are cleared, scanner hardware clears `SGO`, sets `SCANIF`, and sets the Scan Abort Signal (`DABORT`) bit.

The `SCANIF` bit can only be cleared by software. If the Scanner Interrupt Enable (`SCANIE`) bit is set and hardware sets `SCANIF`, an interrupt event will occur.

19.10.1 Operation During Interrupts

The Scanner Interrupt Management Mode Select (`INTM`) bit determines scanner priority during an interrupt event.

When `INTM = 0` and the `MD` bits select Burst mode, scanner operation is given higher priority than the interrupt response. This allows the scanner to delay the interrupt response until the scan operation is complete, but at the expense of increased interrupt response time.

When `INTM = 0` and the `MD` bits select Concurrent or Triggered modes, the scanner accesses memory during the interrupt response. Scanner hardware will stall the CPU while the scan operation

is in progress. Once the scan is complete, CPU operation resumes, allowing the interrupt response to resume. Interrupt response time is increased by one instruction cycle each time the scanner accesses memory during the interrupt response.

When INTM = 1, the interrupt response is given higher priority than the scanner operation. Scanner operation is delayed until the interrupt response is complete. This allows interrupts to be serviced immediately, but decreases scanner throughput time.

The INTM bit has no effect on scanner or interrupt priority in Peek mode.

19.11 WWDT Interaction

The Windowed Watch Dog Timer (WWDT) operates in the background during scanner activity. It is possible that long scans, particularly in Burst mode, may exceed the WWDT time-out period and result in an undesired device Reset. This must be considered when performing memory scans with an application that also utilizes WWDT.

19.12 Operation During Sleep

If a SLEEP instruction is executed during operation, the module will be suspended in its current state until the device wakes from Sleep.

19.13 Peripheral Module Disable

Both the CRC and scanner module can be disabled individually by setting the CRCMD and SCANMD bits of one of the PMD registers (see the “PMD - Peripheral Module Disable” chapter for more details). The SCANMD bit can be used to enable or disable the scanner module only if the SCANE Configuration bit is set. If the SCANE bit is cleared, then the scanner module is not available for use and the SCANMD bit is ignored.

19.14 Register Definitions: CRC and Scanner Control

Long bit name prefixes for the CRC are shown in the table below. Refer to the “Long Bit Names” section in the “Register and Bit Naming Conventions” chapter for more information.

Table 19-1. CRC Long Bit Name Prefixes

Peripheral	Bit Name Prefix
CRC	CRC

19.14.1 CRCCON0**Name:** CRCCON0**Offset:** 0x1CA2

CRC Control Register 0

Bit	7	6	5	4	3	2	1	0
	EN	GO	BUSY	ACCM	SETUP[1:0]		SHIFTM	FULL
Access	R/W	R/W	R	R/W	R/W		R/W	R
Reset	0	0	0	0	0		0	0

Bit 7 – EN CRC Enable

Value	Description
1	CRC module is released from Reset
0	CRC is disabled and consumes no operating current

Bit 6 – GO CRC Start

Value	Description
1	Start CRC serial shifter
0	CRC serial shifter turned off

Bit 5 – BUSY CRC Busy

Value	Description
1	Shifting in progress or pending
0	All valid bits in shifter have been shifted into accumulator and EMPTY = 1

Bit 4 – ACCM Accumulator Mode

Value	Description
1	Data are augmented with zeros
0	Data are not augmented with zeros

Bits 4:3 – SETUP[1:0]

Register Overlay Setup

Value	Description
11	CRC Register Overlay Selection; Read / Write access to CRCOUT
10	CRC Register Overlay Selection; Read / Write access to CRCXOR
01	CRC Register Overlay Selection; Read / Write access to CRCSHIFT
00	CRC Register Overlay Selection; Read / Write access to CRCOUT

Bit 1 – SHIFTM Shift Mode

Value	Description
1	Shift right (LSb first)
0	Shift left (MSb first)

Bit 0 – FULL Data Path Full Indicator

Value	Description
1	CRCDATAT/U/H/L registers are full
0	CRCDATAT/U/H/L registers have shifted their data into the shifter

19.14.2 CRCCON1

Name: CRCCON1
Offset: 0x1CA3

CRC Control Register 1

Bit	7	6	5	4	3	2	1	0
				PLEN[4:0]				
Access				R/W	R/W	R/W	R/W	R/W
Reset				0	0	0	0	0

Bits 4:0 – PLEN[4:0] Polynomial Length
Denotes the length of the polynomial (n-1)

19.14.3 CRCCON2**Name:** CRCCON2**Offset:** 0x1CA4

CRC Control Register 2

Bit	7	6	5	4	3	2	1	0	
				DLEN[4:0]					
Access				R/W	R/W	R/W	R/W	R/W	
Reset				0	0	0	0	0	

Bits 4:0 – DLEN[4:0] Data Length
Denotes the length of the data word (n-1)

19.14.4 CRCDATA**Name:** CRCDATA**Offset:** 0x1C9A

CRC Data Registers

Bit	31	30	29	28	27	26	25	24
	CRCDATAT[7:0]							
Access	R/W	R/W	R/W	R/W	R/W	R/W	R/W	R/W
Reset	0	0	0	0	0	0	0	0
Bit	23	22	21	20	19	18	17	16
	CRCDATAU[7:0]							
Access	R/W	R/W	R/W	R/W	R/W	R/W	R/W	R/W
Reset	0	0	0	0	0	0	0	0
Bit	15	14	13	12	11	10	9	8
	CRCDATAH[7:0]							
Access	R/W	R/W	R/W	R/W	R/W	R/W	R/W	R/W
Reset	0	0	0	0	0	0	0	0
Bit	7	6	5	4	3	2	1	0
	CRCDATAL[7:0]							
Access	R/W	R/W	R/W	R/W	R/W	R/W	R/W	R/W
Reset	0	0	0	0	0	0	0	0

Bits 31:24 – CRCDATAT[7:0] CRC Data Top Byte**Bits 23:16 – CRCDATAU[7:0]** CRC Data Upper Byte**Bits 15:8 – CRCDATAH[7:0]** CRC Data High Byte**Bits 7:0 – CRCDATAL[7:0]** CRC Data Low Byte

19.14.5 CRCOUT

Name: CRCOUT

Offset: 0x1C9E

CRC Output Registers

Bit	31	30	29	28	27	26	25	24
	CRCOUTT[7:0]							
Access	R/W	R/W	R/W	R/W	R/W	R/W	R/W	R/W
Reset	0	0	0	0	0	0	0	0
Bit	23	22	21	20	19	18	17	16
	CRCOUTU[7:0]							
Access	R/W	R/W	R/W	R/W	R/W	R/W	R/W	R/W
Reset	0	0	0	0	0	0	0	0
Bit	15	14	13	12	11	10	9	8
	CRCOUTH[7:0]							
Access	R/W	R/W	R/W	R/W	R/W	R/W	R/W	R/W
Reset	0	0	0	0	0	0	0	0
Bit	7	6	5	4	3	2	1	0
	CRCOUTL[7:0]							
Access	R/W	R/W	R/W	R/W	R/W	R/W	R/W	R/W
Reset	0	0	0	0	0	0	0	0

Bits 31:24 – CRCOUTT[7:0] CRC Output Register Top Byte

Writing to this register writes the Most Significant Byte of the CRC output register. Reading from this register reads the Most Significant Byte of the CRC output.

Bits 23:16 – CRCOUTU[7:0] CRC Output Register Upper Byte

Bits 15:8 – CRCOUTH[7:0] CRC Output Register High Byte

Bits 7:0 – CRCOUTL[7:0] CRC Output Register Low Byte

Writing to this register writes the Least Significant Byte of the CRC output register. Reading from this register reads the Least Significant Byte of the CRC output.

19.14.6 CRCSHIFT

Name: CRCSHIFT

Offset: 0x1C9E

CRC Shift Registers

Bit	31	30	29	28	27	26	25	24
	CRCSHIFTT[7:0]							
Access	R	R	R	R	R	R	R	R
Reset	0	0	0	0	0	0	0	0
Bit	23	22	21	20	19	18	17	16
	CRCSHIFTU[7:0]							
Access	R	R	R	R	R	R	R	R
Reset	0	0	0	0	0	0	0	0
Bit	15	14	13	12	11	10	9	8
	CRCSHIFTH[7:0]							
Access	R	R	R	R	R	R	R	R
Reset	0	0	0	0	0	0	0	0
Bit	7	6	5	4	3	2	1	0
	CRCSHIFTL[7:0]							
Access	R	R	R	R	R	R	R	R
Reset	0	0	0	0	0	0	0	0

Bits 31:24 – CRCSHIFTT[7:0] CRC Shift Register Top Byte

Reading from this register reads the Most Significant Byte of the CRC Shifter.

Bits 23:16 – CRCSHIFTU[7:0] CRC Shift Register Upper Byte

Bits 15:8 – CRCSHIFTH[7:0] CRC Shift Register High Byte

Bits 7:0 – CRCSHIFTL[7:0] CRC Shift Register Low Byte

Reading from this register reads the Least Significant Byte of the CRC Shifter.

19.14.7 CRCXOR**Name:** CRCXOR**Offset:** 0x1C9E

CRC XOR Registers

Bit	31	30	29	28	27	26	25	24
	CRCXORT[7:0]							
Access	R/W	R/W	R/W	R/W	R/W	R/W	R/W	R/W
Reset	0	0	0	0	0	0	0	0
Bit	23	22	21	20	19	18	17	16
	CRCXORU[7:0]							
Access	R/W	R/W	R/W	R/W	R/W	R/W	R/W	R/W
Reset	0	0	0	0	0	0	0	0
Bit	15	14	13	12	11	10	9	8
	CRCXORH[7:0]							
Access	R/W	R/W	R/W	R/W	R/W	R/W	R/W	R/W
Reset	0	0	0	0	0	0	0	0
Bit	7	6	5	4	3	2	1	0
	CRCXORL[7:0]							
Access	R/W	R/W	R/W	R/W	R/W	R/W	R/W	R/W
Reset	0	0	0	0	0	0	0	0

Bits 31:24 – CRCXORT[7:0] XOR of Polynomial Term XN Enable Top Byte**Bits 23:16 – CRCXORU[7:0]** XOR of Polynomial Term XN Enable Upper Byte**Bits 15:8 – CRCXORH[7:0]** XOR of Polynomial Term XN Enable High Byte**Bits 7:0 – CRCXORL[7:0]** XOR of Polynomial Term XN Enable Low Byte

19.14.8 SCANCON0**Name:** SCANCON0**Offset:** 0x1C98

Scanner Access Control Register 0

Bit	7	6	5	4	3	2	1	0
	EN	SGO	BUSY	DABORT	INTM		MD[1:0]	
Access	R/W	R/W/HC	R	R	R/W		R/W	R/W
Reset	0	0	0	1	0		0	0

Bit 7 – EN Scanner Enable⁽¹⁾

Value	Description
1	Scanner is enabled
0	Scanner is disabled

Bit 6 – SGO Scanner GO^(2,3)

Value	Description
1	Begin scanner operations
0	Scanner operations will not occur

Bit 5 – BUSY Scanner Busy Indicator

Value	Description
1	Scanner cycle is in process
0	Scanner cycle is complete (or never started)

Bit 4 – DABORT Scanner Abort Signal

Value	Description
1	SCANLADR points to an invalid NVM address, or the CRC is disabled
0	SCANLADR points to a valid NVM address and the CRC is enabled

Bit 3 – INTM Scanner Interrupt Management Mode Select

Value	Name	Description
1	MD = '00', '01', or '11'	Scan operations are paused during the interrupt response and resume after the interrupt has been serviced
0	MD = '00' or '11'	Interrupt operations are stalled each time the scanner accesses memory and resume between scan operations
0	MD = '01'	Interrupt operations are stalled until SGO is cleared by hardware
×	MD = '10'	This bit is ignored

Bits 1:0 – MD[1:0] Scanner Memory Access Mode Select⁽⁴⁾

Value	Description
11	Trigger Mode
10	Peek Mode
01	Burst Mode
00	Concurrent Mode

Notes:

- Setting EN = 0 does not affect any other register content.
- This bit can be cleared in software. It is cleared in hardware when LADR > HADR (and a data cycle is not occurring) or when **CRCGO** = 0.
- CRCEN** and **CRCGO** bits must be set before setting the SGO bit.
- Trigger Mode source selection can be set using the SCANTRIG register.

19.14.9 SCANLADR

Name: SCANLADR

Offset: 0x1C95

Scan Low Address Registers

Bit	15	14	13	12	11	10	9	8
	SCANLADRH[7:0]							
Access	R/W	R/W	R/W	R/W	R/W	R/W	R/W	R/W
Reset	0	0	0	0	0	0	0	0
Bit	7	6	5	4	3	2	1	0
	SCANLADRL[7:0]							
Access	R/W	R/W	R/W	R/W	R/W	R/W	R/W	R/W
Reset	0	0	0	0	0	0	0	0

Bits 15:8 – SCANLADRH[7:0] Scan Start/Current Address high byte
High byte of the current address to be fetched from, value increments on each fetch of memory.

Bits 7:0 – SCANLADRL[7:0] Scan Start/Current Address low byte
Low byte of the current address to be fetched from, value increments on each fetch of memory.

Notes:

1. Registers SCANLADRH/L form a 16-bit value, but are not guarded for atomic or asynchronous access; registers may only be read or written while **SGO** = 0.
2. While **SGO** = 1, writing to this register is ignored.

19.14.10 SCANHADR**Name:** SCANHADR**Offset:** 0x1C92

Scan High Address Registers

Bit	15	14	13	12	11	10	9	8
	SCANHADRH[7:0]							
Access	R/W	R/W	R/W	R/W	R/W	R/W	R/W	R/W
Reset	1	1	1	1	1	1	1	1
Bit	7	6	5	4	3	2	1	0
	SCANHADRL[7:0]							
Access	R/W	R/W	R/W	R/W	R/W	R/W	R/W	R/W
Reset	1	1	1	1	1	1	1	1

Bits 15:8 – SCANHADRH[7:0] Scan End Address
High byte of the address at the end of the designated scan.

Bits 7:0 – SCANHADRL[7:0] Scan End Address
Low byte of the address at the end of the designated scan.

Notes:

1. Registers SCANHADRH/L form a 16-bit value, but are not guarded for atomic or asynchronous access; registers may only be read or written while **SGO** = 0.
2. While **SGO** = 1, writing to this register is ignored.

19.14.11 SCANTRIG

Name: SCANTRIG

Offset: 0x1C99

SCAN Trigger Selection Register

Bit	7	6	5	4	3	2	1	0
					TSEL[3:0]			
Access					R/W	R/W	R/W	R/W
Reset					0	0	0	0

Bits 3:0 – TSEL[3:0] Scanner Data Trigger Input Selection

Table 19-2. Scanner Data Trigger Input Sources⁽¹⁾

TSEL Value	Trigger Input Sources
1111–1100	Reserved
1011	CLC4_OUT
1010	CLC3_OUT
1001	CLC2_OUT
1000	CLC1_OUT
0111	Reserved
0110	TMR4_Postscaled_OUT
0101	TMR3_overflow
0100	TMR2_Postscaled_OUT
0011	TMR1_overflow
0010	TMR0_overflow
0001	CLKR_OUT
0000	LFINTOSC

Note:

1. The number of implemented bits varies by device.

19.15 Register Summary - CRC

Offset	Name	Bit Pos.	7	6	5	4	3	2	1	0	
0x00 ...	Reserved										
0x1C91											
0x1C92	SCANHADR	7:0	SCANHADRL[7:0]								
		15:8	SCANHADRH[7:0]								
0x1C94	Reserved										
0x1C95	SCANLADR	7:0	SCANLADRL[7:0]								
		15:8	SCANLADRH[7:0]								
0x1C97	Reserved										
0x1C98	SCANCON0	7:0	EN	SGO	BUSY	DABORT	INTM		MD[1:0]		
0x1C99	SCANTRIG	7:0						TSEL[3:0]			
0x1C9A	CRCDATA	7:0	CRCDATA[7:0]								
		15:8	CRCDATAH[7:0]								
		23:16	CRCDATAU[7:0]								
		31:24	CRCDATAT[7:0]								
0x1C9E	CRCOUT	7:0	CRCOUTL[7:0]								
		15:8	CRCOUTH[7:0]								
		23:16	CRCOUTU[7:0]								
		31:24	CRCOUTT[7:0]								
0x1C9E	CRCSHIFT	7:0	CRCSHIFTL[7:0]								
		15:8	CRCSHIFTH[7:0]								
		23:16	CRCSHIFU[7:0]								
		31:24	CRCSHIFTT[7:0]								
0x1C9E	CRCXOR	7:0	CRCXORL[7:0]								
		15:8	CRCXORH[7:0]								
		23:16	CRCXORU[7:0]								
		31:24	CRCXORT[7:0]								
0x1CA2	CRCCON0	7:0	EN	GO	BUSY	ACCM	SETUP[1:0]	SHIFTM	FULL		
0x1CA3	CRCCON1	7:0					PLEN[4:0]				
0x1CA4	CRCCON2	7:0					DLEN[4:0]				

20. PMD - Peripheral Module Disable

20.1 Overview

This module provides the ability to selectively enable or disable a peripheral. Disabling a peripheral places it in its lowest possible Power state. The user can selectively disable unused modules to reduce the overall power consumption.



Important: All modules are ON by default following any system Reset.

20.2 Disabling a Module

A peripheral can be disabled by setting the corresponding peripheral disable bit in the PMDx register. Disabling a module has the following effects:

- The module is held in Reset and does not function
- All the SFRs pertaining to that peripheral become “unimplemented”
 - Writing is disabled
 - Reading returns 0x00
- Module outputs are disabled

20.3 Enabling a Module

Clearing the corresponding module disable bit in the PMDx register, re-enables the module and the SFRs will reflect the Power-on Reset values.



Important: There will be no reads/writes to the module SFRs for at least two instruction cycles after it has been re-enabled.

20.4 Register Definitions: Peripheral Module Disable

20.4.1 PMD0

Name: PMD0
Offset: 0x010C

PMD Control Register 0

Bit	7	6	5	4	3	2	1	0
	TMR0MD	CLKRMD	IOCMD	ACTMD	SYSCMD	SCANMD	CRCMD	NVMMD
Access	R/W	R/W	R/W	R/W	R/W	R/W	R/W	R/W
Reset	0	0	0	0	0	0	0	0

Bit 7 – TMR0MD Disable TMR0

Value	Description
1	TMR0 module disabled
0	TMR0 module enabled

Bit 6 – CLKRMD Disable Clock Reference

Value	Description
1	Clock reference module disabled
0	Clock reference module enabled

Bit 5 – IOCMD Disable Interrupt-on-Change

Value	Description
1	Interrupt-on-change module is disabled
0	Interrupt-on-change module is enabled

Bit 4 – ACTMD Disable Active Clock Tuning

Value	Description
1	ACT module disabled
0	ACT module enabled

Bit 3 – SYSCMD Disable Peripheral System Clock Network⁽¹⁾

Value	Description
1	System clock network disabled (F_{OSC})
0	System clock network enabled

Bit 2 – SCANMD Disable NVM Memory Scanner

Value	Description
1	NVM memory scanner module disabled
0	NVM memory scanner module enabled

Bit 1 – CRCMD Disable CRC Module

Value	Description
1	CRC module disabled
0	CRC module enabled

Bit 0 – NVMMD Disable NVM access

Value	Description
1	All memory reading and writing is disabled; NVMCON registers cannot be written
0	All memory reading and writing is enabled

Note:

1. Clearing the SYSCMD bit disables the system clock (F_{OSC}) to peripherals, however peripherals clocked by $F_{OSC}/4$ are not affected.

20.4.2 PMD1

Name: PMD1
Offset: 0x010D

PMD Control Register 1

Bit	7	6	5	4	3	2	1	0
	PWM1MD	CCP2MD	CCP1MD		TMR4MD	TMR2MD	TMR3MD	TMR1MD
Access	R/W	R/W	R/W		R/W	R/W	R/W	R/W
Reset	0	0	0		0	0	0	0

Bit 7 – PWM1MD Disable PWM1 Module

Value	Description
1	PWM1 module disabled
0	PWM1 module enabled

Bit 6 – CCP2MD Disable CCP2 Module

Value	Description
1	CCP2 module disabled
0	CCP2 module enabled

Bit 5 – CCP1MD Disable CCP1 Module

Value	Description
1	CCP1 module disabled
0	CCP1 module enabled

Bit 3 – TMR4MD Disable Timer TMR4

Value	Description
1	TMR4 module disabled
0	TMR4 module enabled

Bit 2 – TMR2MD Disable Timer TMR2

Value	Description
1	TMR2 module disabled
0	TMR2 module enabled

Bit 1 – TMR3MD Disable Timer TMR3

Value	Description
1	TMR3 module disabled
0	TMR3 module enabled

Bit 0 – TMR1MD Disable Timer TMR1

Value	Description
1	TMR1 module disabled
0	TMR1 module enabled

20.4.3 PMD2

Name: PMD2
Offset: 0x010E

PMD Control Register 2

Bit	7	6	5	4	3	2	1	0
	CLC3MD	CLC2MD	CLC1MD	CWG1MD	NCO1MD			PWM2MD
Access	R/W	R/W	R/W	R/W	R/W			R/W
Reset	0	0	0	0	0			0

Bit 7 – CLC3MD Disable CLC3

Value	Description
1	CLC3 disabled
0	CLC3 enabled

Bit 6 – CLC2MD Disable CLC2

Value	Description
1	CLC2 disabled
0	CLC2 enabled

Bit 5 – CLC1MD Disable CLC1

Value	Description
1	CLC1 disabled
0	CLC1 enabled

Bit 4 – CWG1MD Disable CWG1

Value	Description
1	CWG1 disabled
0	CWG1 enabled

Bit 3 – NCO1MD Disable NCO1

Value	Description
1	NCO1 disabled
0	NCO1 enabled

Bit 0 – PWM2MD Disable PWM2

Value	Description
1	PWM2 disabled
0	PWM2 enabled

20.4.4 PMD3

Name: PMD3
Offset: 0x010F

PMD Control Register 3

Bit	7	6	5	4	3	2	1	0
	CM2MD	CM1MD	FVRMD	MSSP2MD	MSSP1MD	UART2MD	UART1MD	CLC4MD
Access	R/W	R/W	R/W	R/W	R/W	R/W	R/W	R/W
Reset	0	0	0	0	0	0	0	0

Bit 7 – CM2MD Disable Comparator 2

Value	Description
1	CM2 module disabled
0	CM2 module enabled

Bit 6 – CM1MD Disable Comparator 1

Value	Description
1	CM1 module disabled
0	CM1 module enabled

Bit 5 – FVRMD Disable Fixed Voltage Reference Module

Value	Description
1	FVR module disabled
0	FVR module enabled

Bit 4 – MSSP2MD Disable MSSP2 Module

Value	Description
1	MSSP2 module disabled
0	MSSP2 module enabled

Bit 3 – MSSP1MD Disable MSSP1 Module

Value	Description
1	MSSP1 module disabled
0	MSSP1 module enabled

Bit 2 – UART2MD Disable UART2 Module

Value	Description
1	UART2 module disabled
0	UART2 module enabled

Bit 1 – UART1MD Disable UART1 Module

Value	Description
1	UART1 module disabled
0	UART1 module enabled

Bit 0 – CLC4MD Disable CLC4

Value	Description
1	CLC4 disabled
0	CLC4 enabled

20.4.5 PMD4

Name: PMD4
Offset: 0x0110

PMD Control Register 4

Bit	7	6	5	4	3	2	1	0
				ZCDMD		DAC2MD	DAC1MD	ADCMD
Access				R/W		R/W	R/W	R/W
Reset				0		0	0	0

Bit 4 - ZCDMD Disable Zero Cross Detect⁽¹⁾

Value	Description
1	ZCD module disabled
0	ZCD module enabled

Bit 2 - DAC2MD Disable Digital-to-Analog Converter 2

Value	Description
1	DAC2 module disabled
0	DAC2 module enabled

Bit 1 - DAC1MD Disable Digital-to-Analog Converter 1

Value	Description
1	DAC1 module disabled
0	DAC1 module enabled

Bit 0 - ADCMD Disable Analog-to-Digital Converter

Value	Description
1	ADC module disabled
0	ADC module enabled

Note:

1. Subject to the value of $\overline{\text{ZCD}}$ Configuration bit.

20.5 Register Summary - PMD

Offset	Name	Bit Pos.	7	6	5	4	3	2	1	0
0x00 ...	Reserved									
0x010B										
0x010C	PMD0	7:0	TMR0MD	CLKRMD	IOCMD	ACTMD	SYSCMD	SCANMD	CRCMD	NVMMD
0x010D	PMD1	7:0	PWM1MD	CCP2MD	CCP1MD		TMR4MD	TMR2MD	TMR3MD	TMR1MD
0x010E	PMD2	7:0	CLC3MD	CLC2MD	CLC1MD	CWG1MD	NCO1MD			PWM2MD
0x010F	PMD3	7:0	CM2MD	CM1MD	FVRMD	MSSP2MD	MSSP1MD	UART2MD	UART1MD	CLC4MD
0x0110	PMD4	7:0				ZCDMD		DAC2MD	DAC1MD	ADCMD

21. CLKREF - Reference Clock Output Module

The reference clock output module provides the ability to send a clock signal to the clock reference output pin (CLKR). The reference clock output can be routed internally as an input signal for other peripherals, such as the timers and CLCs.

The reference clock output module has the following features:

- Selectable clock source using the [CLKRCLK](#) register
- Programmable clock divider
- Selectable duty cycle

The figure below shows the simplified block diagram of the clock reference module.

Figure 21-1. Clock Reference Block Diagram

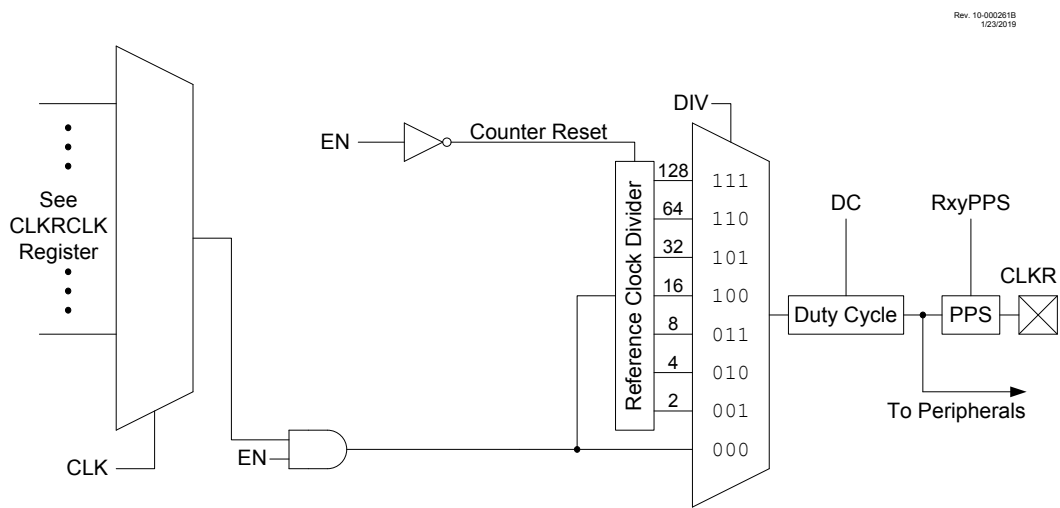
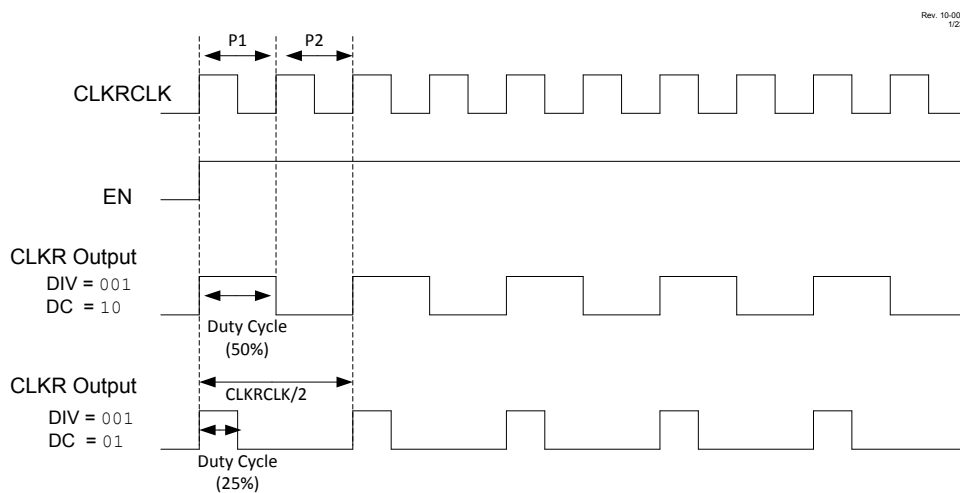

Figure 21-2. Clock Reference Timing



21.1 Clock Source

The clock source of the reference clock peripheral is selected with the [CLK](#) bits.

21.1.1 Clock Synchronization

The CLKR output signal is ensured to be glitch-free when the **EN** bit is set to start the module and enable the CLKR output. When the reference clock output is disabled, the output signal will be disabled immediately.

21.2 Programmable Clock Divider

The module takes the clock input and divides it based on the value of the **DIV** bits.

The following configurations are available:

- Base clock frequency value
- Base clock frequency divided by 2
- Base clock frequency divided by 4
- Base clock frequency divided by 8
- Base clock frequency divided by 16
- Base clock frequency divided by 32
- Base clock frequency divided by 64
- Base clock frequency divided by 128

21.3 Selectable Duty Cycle

The **DC** bits are used to modify the duty cycle of the output clock. A duty cycle of 0%, 25%, 50%, or 75% can be selected for all clock rates when the **DIV** value is not 0b000. When **DIV** = 0b000, the duty cycle defaults to 50% for all values of **DC** except 0b00, in which case the duty cycle is 0% (constant low output).



Important: The **DC** value at Reset is 10. This makes the default duty cycle 50% and not 0%.



Important: Clock dividers and clock duty cycles can be changed while the module is enabled but doing so may cause glitches to occur on the output. To avoid possible glitches, clock dividers and clock duty cycles will be changed only when the **EN** bit is clear.

21.4 Operation in Sleep Mode

The reference clock module continues to operate and provide a signal output in Sleep for all clock source selections except F_{OSC} (**CLK** = 0).

21.5 Register Definitions: Reference Clock

Long bit name prefixes for the Reference Clock peripherals are shown in the following table. Refer to the “**Long Bit Names**” section in the “**Register and Bit Naming Conventions**” chapter for more information.

Table 21-1. CLKREF Long Bit Name Prefixes

Peripheral	Bit Name Prefix
CLKR	CLKR

21.5.1 CLKRCON

Name: CLKRCON

Offset: 0x0296

Reference Clock Control Register

Bit	7	6	5	4	3	2	1	0
	EN			DC[1:0]		DIV[2:0]		
Access	R/W			R/W	R/W	R/W	R/W	R/W
Reset	0			1	0	0	0	0

Bit 7 – EN Reference Clock Module Enable

Value	Description
1	Reference clock module enabled
0	Reference clock module is disabled

Bits 4:3 – DC[1:0] Reference Clock Duty Cycle⁽¹⁾

Value	Description
11	Clock outputs duty cycle of 75%
10	Clock outputs duty cycle of 50%
01	Clock outputs duty cycle of 25%
00	Clock outputs duty cycle of 0%

Bits 2:0 – DIV[2:0] Reference Clock Divider

Value	Description
111	Base clock value divided by 128
110	Base clock value divided by 64
101	Base clock value divided by 32
100	Base clock value divided by 16
011	Base clock value divided by 8
010	Base clock value divided by 4
001	Base clock value divided by 2
000	Base clock value

Note:

- Bits are valid for $DIV \geq 001$. For $DIV = 000$, duty cycle is fixed at 50%.

21.5.2 CLKRCLK

Name: CLKRCLK

Offset: 0x0297

Clock Reference Clock Selection Register

Bit	7	6	5	4	3	2	1	0
					CLK[3:0]			
Access					R/W	R/W	R/W	R/W
Reset					0	0	0	0

Bits 3:0 – CLK[3:0] CLKR Clock Selection

Table 21-2. Clock Reference Module Clock Sources

CLK	Clock Source
1111–1100	Reserved
1011	CLC4_OUT
1010	CLC3_OUT
1001	CLC2_OUT
1000	CLC1_OUT
0111	NCO1_OUT
0110	EXTOSC
0101	SOSC
0100	MFINTOSC (32 kHz)
0011	MFINTOSC (500 kHz)
0010	LFINTOSC
0001	HFINTOSC
0000	F _{osc}

21.6 Register Summary - Reference CLK

Offset	Name	Bit Pos.	7	6	5	4	3	2	1	0
0x00	Reserved									
...										
0x0295										
0x0296	CLKRCON	7:0	EN			DC[1:0]		DIV[2:0]		
0x0297	CLKRCLK	7:0						CLK[3:0]		

22. TMR0 - Timer0 Module

The Timer0 module has the following features:

- 8-bit timer with programmable period
- 16-bit timer
- Selectable clock sources
- Synchronous and asynchronous operation
- Programmable prescaler (Independent of Watchdog Timer)
- Programmable postscaler
- Interrupt on match or overflow
- Output on I/O pin (via PPS) or to other peripherals
- Operation during Sleep

Figure 22-1. Timer0 Block Diagram

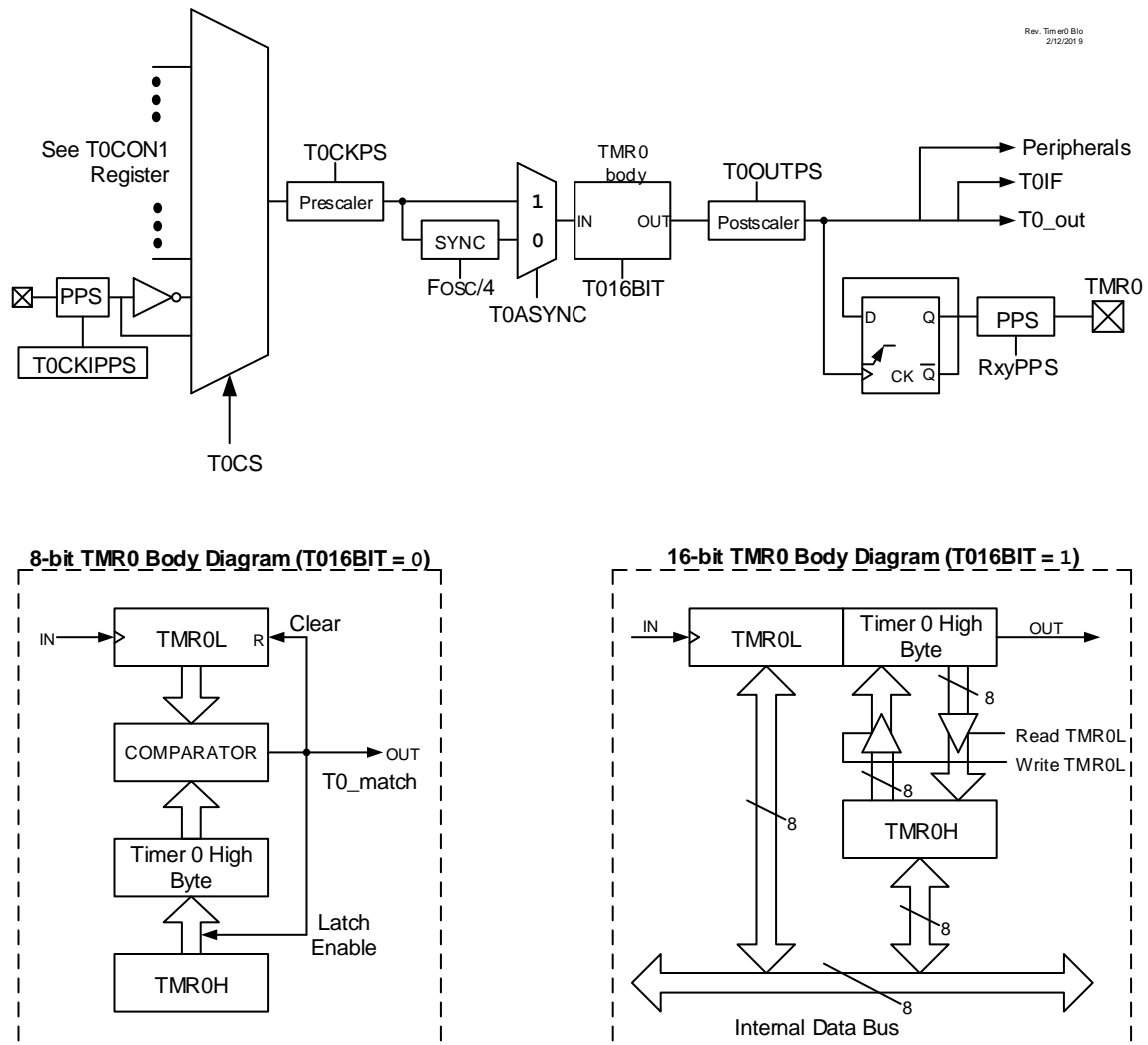

22.1 Timer0 Operation

Timer0 can operate as either an 8-bit or 16-bit timer. The mode is selected with the MD16 bit.

22.1.1 8-Bit Mode

In this mode, Timer0 increments on the rising edge of the selected clock source. A prescaler on the clock input gives several prescale options (see the prescaler control bits, CKPS). In this mode, as shown in Figure 22-1, a buffered version of TMR0H is maintained.

This is compared with the value of TMR0L on each cycle of the selected clock source. When the two values match, the following events occur:

- TMR0L is reset
- The contents of TMR0H are copied to the TMR0H buffer for next comparison

22.1.2 16-Bit Mode

In this mode, Timer0 increments on the rising edge of the selected clock source. A prescaler on the clock input gives several prescale options (see the prescaler control bits, CKPS). In this mode, TMR0H:TMR0L form the 16-bit timer value. As shown in Figure 22-1, reads and writes of the TMR0H register are buffered. The TMR0H register is updated with the contents of the high byte of Timer0 when the TMR0L register is read. Similarly, writing the TMR0L register causes a transfer of the TMR0H register value to the Timer0 high byte.

This buffering allows all 16 bits of Timer0 to be read and written at the same time. Timer0 rolls over to 0x0000 on incrementing past 0xFFFF. This makes the timer free-running. While actively operating in 16-bit mode, the Timer0 value can be read but not written.

22.2 Clock Selection

Timer0 has several options for clock source selections, the option to operate synchronously/asynchronously and an available programmable prescaler. The CS bits are used to select the clock source for Timer0.

22.2.1 Synchronous Mode

When the ASYNC bit is clear, Timer0 clock is synchronized to the system clock ($F_{OSC}/4$). When operating in Synchronous mode, Timer0 clock frequency cannot exceed $F_{OSC}/4$. During Sleep mode, the system clock is not available and Timer0 cannot operate.

22.2.2 Asynchronous Mode

When the ASYNC bit is set, Timer0 increments with each rising edge of the input source (or output of the prescaler, if used). Asynchronous mode allows Timer0 to continue operation during Sleep mode provided the selected clock source operates during Sleep.

22.2.3 Programmable Prescaler

Timer0 has 16 programmable input prescaler options ranging from 1:1 to 1:32768. The prescaler values are selected using the CKPS bits. The prescaler counter is not directly readable or writable. The prescaler counter is cleared on the following events:

- A write to the TMR0L register
- A write to either the T0CON0 or T0CON1 registers
- Any device Reset

22.2.4 Programmable Postscaler

Timer0 has 16 programmable output postscaler options ranging from 1:1 to 1:16. The postscaler values are selected using the OUTPS bits. The postscaler divides the output of Timer0 by the selected ratio. The postscaler counter is not directly readable or writable. The postscaler counter is cleared on the following events:

- A write to the TMR0L register
- A write to either the T0CON0 or T0CON1 registers
- Any device Reset

22.3 Timer0 Output and Interrupt

22.3.1 Timer0 Output

TMR0_out toggles on every match between TMR0L and TMR0H in 8-bit mode or when TMR0H:TMR0L rolls over in 16-bit mode. If the output postscaler is used, the output is scaled by the ratio selected. The Timer0 output can be routed to an I/O pin via the RxyPPS output selection register or internally to a number of Core Independent Peripherals. The Timer0 output can be monitored through software via the **OUT** output bit.

22.3.2 Timer0 Interrupt

The Timer0 Interrupt Flag (TMR0IF) bit is set when the TMR0_out toggles. If the Timer0 interrupt is enabled (TMR0IE), the CPU will be interrupted when the TMR0IF bit is set. When the postscaler bits (T0OUTPS) are set to 1:1 operation (no division), the T0IF flag bit will be set with every TMR0 match or rollover. In general, the TMR0IF flag bit will be set every T0OUTPS +1 matches or rollovers.

22.3.3 Timer0 Example

Timer0 Configuration:

- Timer0 mode = 16-bit
- Clock Source = $F_{OSC}/4$ (250 kHz)
- Synchronous operation
- Prescaler = 1:1
- Postscaler = 1:2 (T0OUTPS = 1)

In this case, the TMR0_out toggles every two rollovers of TMR0H:TMR0L.
i.e., $(0xFFFF)*2*(1/250 \text{ kHz}) = 524.28 \text{ ms}$

22.4 Operation During Sleep

When operating synchronously, Timer0 will halt when the device enters Sleep mode. When operating asynchronously and the selected clock source is active, Timer0 will continue to increment and wake the device from Sleep mode if the Timer0 interrupt is enabled.

22.5 Register Definitions: Timer0 Control

22.5.1 T0CON0

Name: T0CON0
Offset: 0x019E

Timer0 Control Register 0

Bit	7	6	5	4	3	2	1	0
	EN		OUT	MD16	OUTPS[3:0]			
Access	R/W		R	R/W	R/W	R/W	R/W	R/W
Reset	0		0	0	0	0	0	0

Bit 7 – EN TMR0 Enable

Value	Description
1	The module is enabled and operating
0	The module is disabled

Bit 5 – OUT TMR0 Output

Bit 4 – MD16 16-Bit Timer Operation Select

Value	Description
1	TMR0 is a 16-bit timer
0	TMR0 is an 8-bit timer

Bits 3:0 – OUTPS[3:0] TMR0 Output Postscaler (Divider) Select

Value	Description
1111	1:16 Postscaler
1110	1:15 Postscaler
1101	1:14 Postscaler
1100	1:13 Postscaler
1011	1:12 Postscaler
1010	1:11 Postscaler
1001	1:10 Postscaler
1000	1:9 Postscaler
0111	1:8 Postscaler
0110	1:7 Postscaler
0101	1:6 Postscaler
0100	1:5 Postscaler
0011	1:4 Postscaler
0010	1:3 Postscaler
0001	1:2 Postscaler
0000	1:1 Postscaler

22.5.2 T0CON1

Name: T0CON1
Offset: 0x019F

Timer0 Control Register 1

Bit	7	6	5	4	3	2	1	0
	CS[2:0]			ASYNC	CKPS[3:0]			
Access	R/W	R/W	R/W	R/W	R/W	R/W	R/W	R/W
Reset	0	0	0	0	0	0	0	0

Bits 7:5 – CS[2:0] Timer0 Clock Source Select

Table 22-1. Timer0 Clock Source Selections

T0CS	Clock Source
111	CLC1_OUT
110	SOSC
101	MFINTOSC (500 kHz)
100	LFINTOSC
011	HFINTOSC
010	F _{osc} /4
001	Pin selected by T0CKIPPS (Inverted)
000	Pin selected by T0CKIPPS (Noninverted)

Bit 4 – ASYNC TMR0 Input Asynchronization Enable

Value	Description
1	The input to the TMR0 counter is not synchronized to system clocks
0	The input to the TMR0 counter is synchronized to F _{osc} /4

Bits 3:0 – CKPS[3:0] Prescaler Rate Select

Value	Description
1111	1:32768
1110	1:16384
1101	1:8192
1100	1:4096
1011	1:2048
1010	1:1024
1001	1:512
1000	1:256
0111	1:128
0110	1:64
0101	1:32
0100	1:16
0011	1:8
0010	1:4
0001	1:2
0000	1:1

22.5.3 TMR0H

Name: TMR0H
Offset: 0x019D

Timer0 Period/Count High Register

Bit	7	6	5	4	3	2	1	0
	TMR0H[7:0]							
Access	R/W	R/W	R/W	R/W	R/W	R/W	R/W	R/W
Reset	1	1	1	1	1	1	1	1

Bits 7:0 - TMR0H[7:0] TMR0 Most Significant Counter

Value	Condition	Description
0 to 255	MD16 = 0	8-bit Timer0 Period Value. TMR0L continues counting from 0 when this value is reached.
0 to 255	MD16 = 1	16-bit Timer0 Most Significant Byte

22.5.4 TMR0L

Name: TMR0L
Offset: 0x019C

Timer0 Period/Count Low Register

Bit	7	6	5	4	3	2	1	0
	TMR0L[7:0]							
Access	R/W	R/W	R/W	R/W	R/W	R/W	R/W	R/W
Reset	0	0	0	0	0	0	0	0

Bits 7:0 - TMR0L[7:0] TMR0 Least Significant Counter

Value	Condition	Description
0 to 255	MD16 = 0	8-bit Timer0 Counter bits
0 to 255	MD16 = 1	16-bit Timer0 Least Significant Byte

22.6 Register Summary - Timer0

Offset	Name	Bit Pos.	7	6	5	4	3	2	1	0
0x00 ...	Reserved									
0x019B										
0x019C	TMR0L	7:0	TMR0L[7:0]							
0x019D	TMR0H	7:0	TMR0H[7:0]							
0x019E	TOCON0	7:0	EN		OUT	MD16	OUTPS[3:0]			
0x019F	TOCON1	7:0	CS[2:0]			ASYNC	CKPS[3:0]			

23. TMR1 - Timer1 Module with Gate Control

The Timer1 module is a 16-bit timer/counter with the following features:

- 16-bit timer/counter register pair (TMRxH:TMRxL)
- Programmable internal or external clock source
- 2-bit prescaler
- Clock source for optional comparator synchronization
- Multiple Timer1 gate (count enable) sources
- Interrupt-on-overflow
- Wake-up on overflow (external clock, Asynchronous mode only)
- 16-bit read/write operation
- Time base for the capture/compare function with the CCP modules
- Special event trigger (with CCP)
- Selectable gate source polarity
- Gate Toggle mode
- Gate Single Pulse mode
- Gate value status
- Gate event interrupt



Important: References to the module Timer1 apply to all the odd numbered timers on this device.

Figure 23-1. Timer1 Block Diagram

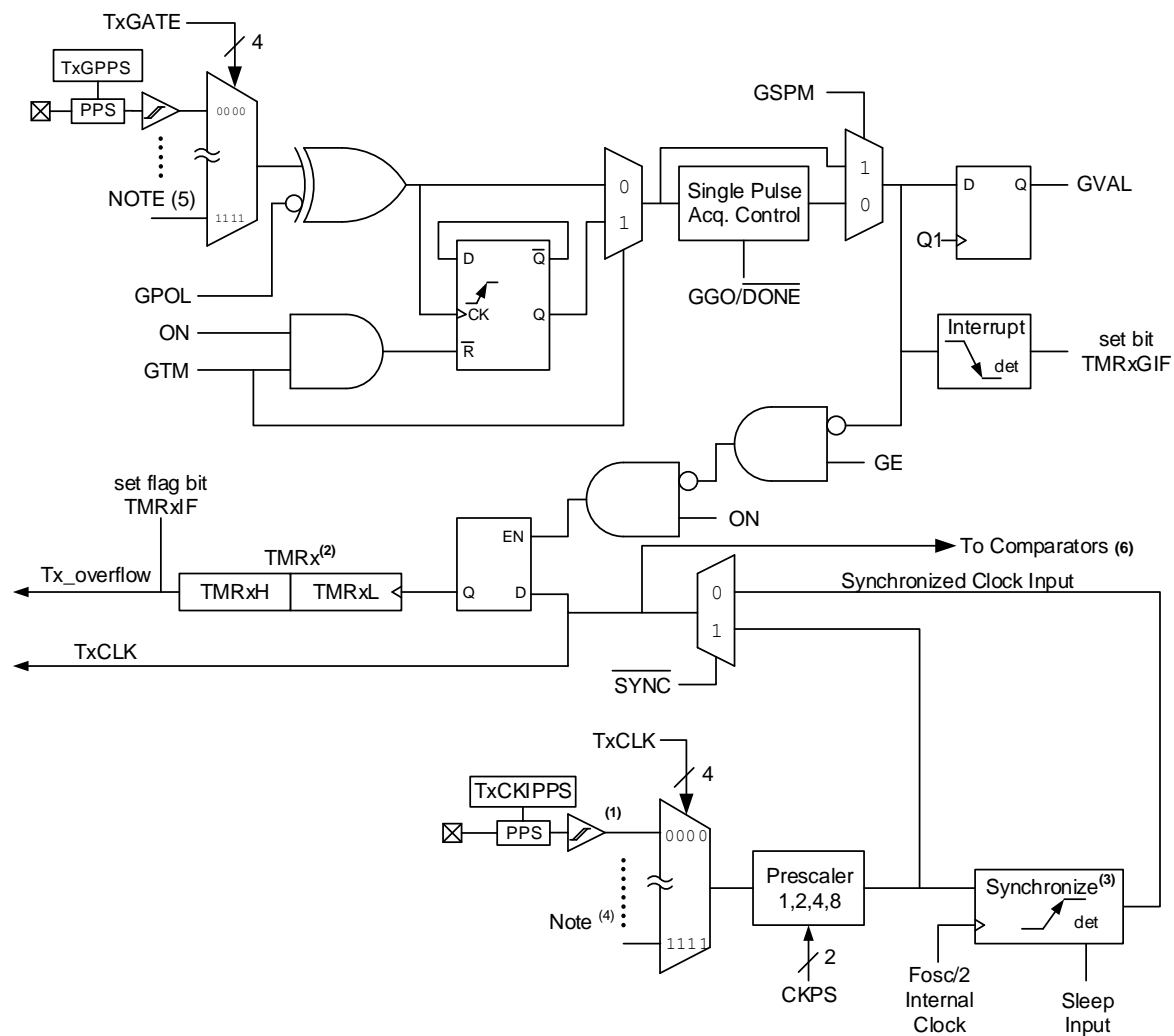
**Notes:**

1. This signal comes from the pin selected by Timer1 PPS register.
2. **TMRx** register increments on rising edge.
3. Synchronize does not operate while in Sleep.
4. See **TxCLK** for clock source selections.
5. See **TxGATE** for gate source selections.
6. Synchronized comparator output must not be used in conjunction with synchronized input clock.

23.1 Timer1 Operation

The Timer1 module is a 16-bit incrementing counter accessed through the **TMRx** register. Writes to **TMRx** directly update the counter. When used with an internal clock source, the module is a timer that increments on every instruction cycle. When used with an external clock source, the module can be used as either a timer or counter and increments on every selected edge of the external source.

Timer1 is enabled by configuring the **ON** and **GE** bits. [Table 23-1](#) shows the possible Timer1 enable selections.

Table 23-1. Timer1 Enable Selections

ON	GE	Timer1 Operation
1	1	Count enabled
1	0	Always on
0	1	Off
0	0	Off

23.2 Clock Source Selection

The **CS** bits select the clock source for Timer1. These bits allow the selection of several possible synchronous and asynchronous clock sources.

23.2.1 Internal Clock Source

When the internal clock source is selected, the **TMRx** register will increment on multiples of F_{OSC} as determined by the Timer1 prescaler.

When the F_{OSC} internal clock source is selected, the **TMRx** register value will increment by four counts every instruction clock cycle. Due to this condition, a two LSB error in resolution will occur when reading the **TMRx** value. To utilize the full resolution of Timer1, an asynchronous input signal must be used to gate the Timer1 clock input.



Important: In Counter mode, a falling edge must be registered by the counter prior to the first incrementing rising edge after any one or more of the following conditions:

- Timer1 enabled after POR
- Write to **TMRxH** or **TMRxL**
- Timer1 is disabled
- Timer1 is disabled (**ON** = 0) when **TxCKI** is high, then Timer1 is enabled (**ON** = 1) when **TxCKI** is low. Refer to the figure below.

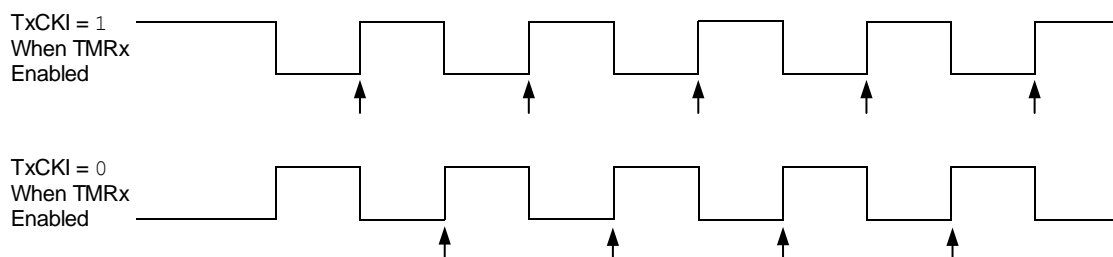
Figure 23-2. Timer1 Incrementing Edge

Notes:

1. Arrows indicate counter increments.
2. In Counter mode, a falling edge must be registered by the counter prior to the first incrementing rising edge of the clock.

23.2.2 External Clock Source

When the external clock source is selected, the **TMRx** module may work as a timer or a counter. When enabled to count, Timer1 is incremented on the rising edge of the external clock input of the **TxCKIPPS** pin. This external clock source can be synchronized to the system clock or it can run asynchronously.

23.3 Timer1 Prescaler

Timer1 has four prescaler options allowing 1, 2, 4 or 8 divisions of the clock input. The **CKPS** bits control the prescale counter. The prescale counter is not directly readable or writable; however, the prescaler counter is cleared upon a write to **TMRx**.

23.4 Secondary Oscillator

A secondary low-power 32.768 kHz oscillator circuit is built-in between pins **SOSCI** (input) and **SOSCO** (amplifier output). This internal circuit is to be used in conjunction with an external 32.768 kHz crystal. The secondary oscillator is not only dedicated to Timer1; it can also be used by other modules.

The oscillator circuit is enabled by setting the **SOSCEN** bit of the **OSCEN** register. This can be used as one of the Timer1 clock sources selected with the **CS** bits. The oscillator will continue to run during Sleep.



Important: The oscillator requires a start-up and stabilization time before use. Thus, the **SOSCEN** bit of the **OSCEN** register must be set and a suitable delay observed prior to enabling Timer1. A software check can be performed to confirm if the secondary oscillator is enabled and ready to use. This is done by polling the secondary oscillator ready Status bit. Refer to the **“OSC - Oscillator Module (With Fail-Safe Clock Monitor)”** chapter for more details.

23.5 Timer1 Operation in Asynchronous Counter Mode

When the **SYNC** Control bit is set, the external clock input is not synchronized. The timer increments asynchronously to the internal phase clocks. If the external clock source is selected, then the timer will continue to run during Sleep and can generate an interrupt on overflow, which will wake up the processor. However, special precautions in software are needed to read/write the timer.



Important: When switching from synchronous to asynchronous operation, it is possible to skip an increment. When switching from asynchronous to synchronous operation, it is possible to produce an additional increment.

23.5.1 Reading and Writing TMRx in Asynchronous Counter Mode

Reading **TMRxH** or **TMRxL** while the timer is running from an external asynchronous clock will ensure a valid read (taken care of in hardware). However, the user must keep in mind that reading the 16-bit timer in two 8-bit values itself poses certain problems, since there may be a carry-out of **TMRxL** to **TMRxH** between the reads.

For writes, it is recommended that the user simply stop the timer and write the desired values. A write contention may occur by writing to the timer registers, while the register is incrementing. This may produce an unpredictable value in the **TMRxH:TMRxL** register pair.

23.6 Timer1 16-Bit Read/Write Mode

Timer1 can be configured to read and write all 16 bits of data to and from the 8-bit **TMRxL** and **TMRxH** registers, simultaneously. The 16-bit read and write operations are enabled by setting the **RD16** bit. To accomplish this function, the **TMRxH** register value is mapped to a buffer register called the **TMRxH** buffer register. While in 16-bit mode, the **TMRxH** register is not directly readable or writable and all read and write operations take place through the use of this **TMRxH** buffer register.

When a read from the **TMRxL** register is requested, the value of the **TMRxH** register is simultaneously loaded into the **TMRxH** buffer register. When a read from the **TMRxH** register is requested, the value is provided from the **TMRxH** buffer register instead. This provides the user with

the ability to accurately read all 16 bits of the Timer1 value from a single instance in time (refer to [Figure 23-3](#) for more details). In contrast, when not in 16-bit mode, the user must read each register separately and determine if the values have become invalid due to a rollover that may have occurred between the read operations.

When a write request of the TMRxL register is requested, the TMRxH buffer register is simultaneously updated with the contents of the TMRxH register. The value of TMRxH must be preloaded into the TMRxH buffer register prior to the write request for the TMRxL register. This provides the user with the ability to write all 16 bits to the TMRx register at the same time. Any requests to write to TMRxH directly does not clear the Timer1 prescaler value. The prescaler value is only cleared through write requests to the TMRxL register.

Figure 23-3. Timer1 16-Bit Read/Write Mode Block Diagram

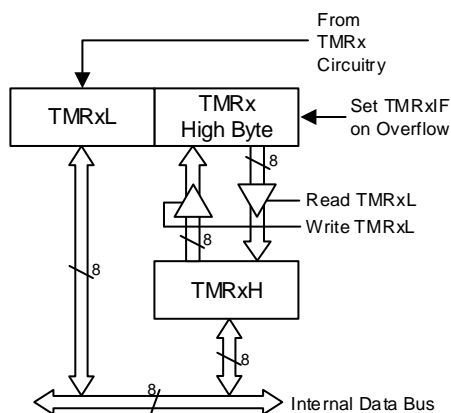

23.7 Timer1 Gate

Timer1 can be configured to count freely or the count can be enabled and disabled using Timer1 gate circuitry. This is also referred to as Timer1 gate enable. Timer1 gate can also be driven by multiple selectable sources.

23.7.1 Timer1 Gate Enable

The Timer1 Gate Enable mode is enabled by setting the **GE** bit. The polarity of the Timer1 Gate Enable mode is configured using the **GPOL** bit.

When Timer1 Gate Enable mode is enabled, Timer1 will increment on the rising edge of the Timer1 clock source. When Timer1 Gate signal is inactive, the timer will not increment and hold the current count. Enable mode is disabled, no incrementing will occur and Timer1 will hold the current count. See [Figure 23-4](#) for timing details.

Table 23-2. Timer1 Gate Enable Selections

TMRxCLK	GPOL	TxG	Timer1 Operation
↑	1	1	Counts
↑	1	0	Holds Count
↑	0	1	Holds Count
↑	0	0	Counts

Figure 23-4. Timer1 Gate Enable Mode

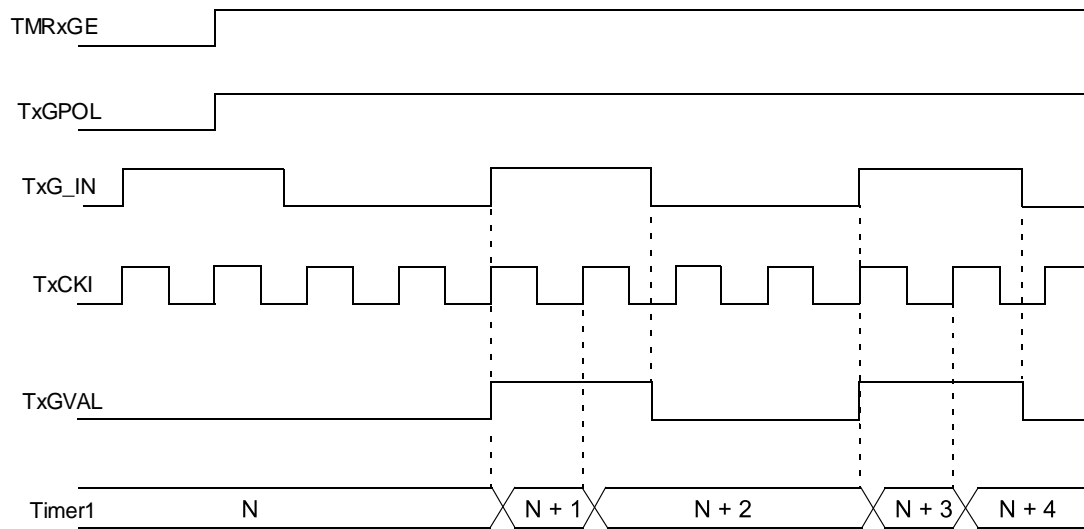

23.7.2 Timer1 Gate Source Selection

The gate source for Timer1 is selected using the **GSS** bits. The polarity selection for the gate source is controlled by the **GPOL** bit.

Any of the above mentioned signals can be used to trigger the gate. The output of the CMPx can be synchronized to the Timer1 clock or left asynchronous. For more information, refer to the **“Comparator Output Synchronization”** section in the **“CMP - Comparator Module”** chapter.

23.7.3 Timer1 Gate Toggle Mode

When Timer1 Gate Toggle mode is enabled, it is possible to measure the full-cycle length of a Timer1 Gate signal, as opposed to the duration of a single-level pulse. The Timer1 gate source is routed through a flip-flop that changes state on every incrementing edge of the signal. See the figure below for timing details.

Timer1 Gate Toggle mode is enabled by setting the **GTM** bit. When the **GTM** bit is cleared, the flip-flop is cleared and held clear. This is necessary to control which edge is measured.



Important: Enabling Toggle mode at the same time as changing the gate polarity may result in indeterminate operation.

Figure 23-5. Timer1 Gate Toggle Mode

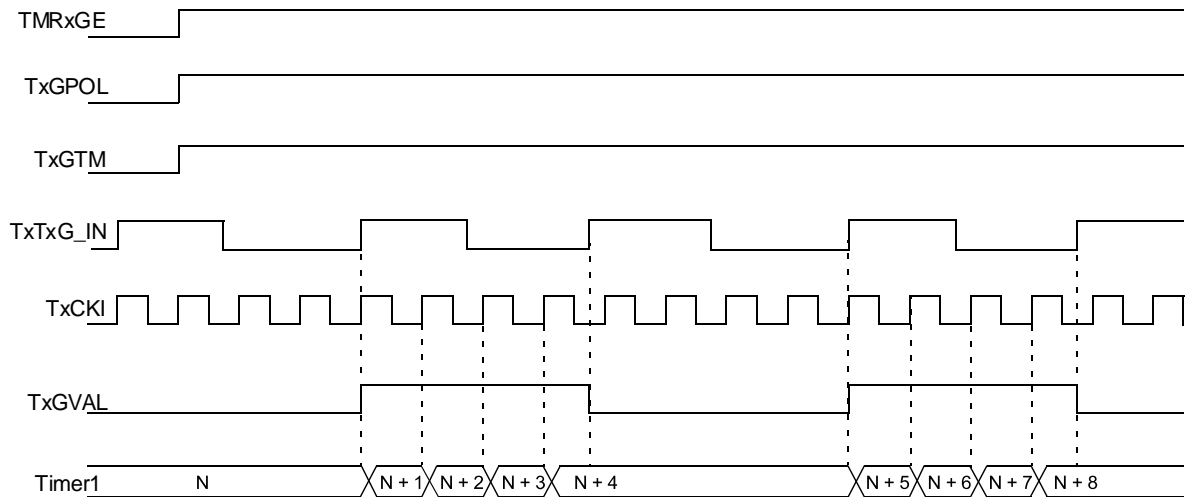

23.7.4 Timer1 Gate Single Pulse Mode

When Timer1 Gate Single Pulse mode is enabled, it is possible to capture a single pulse gate event. Timer1 Gate Single Pulse mode is first enabled by setting the **GSPM** bit. Next, the **GGO/DONE** must be set. The Timer1 will be fully enabled on the next incrementing edge. On the next trailing edge of the pulse, the **GGO/DONE** bit will automatically be cleared. No other gate events will be allowed to increment Timer1 until the **GGO/DONE** bit is once again set in software.

Figure 23-6. Timer1 Gate Single Pulse Mode

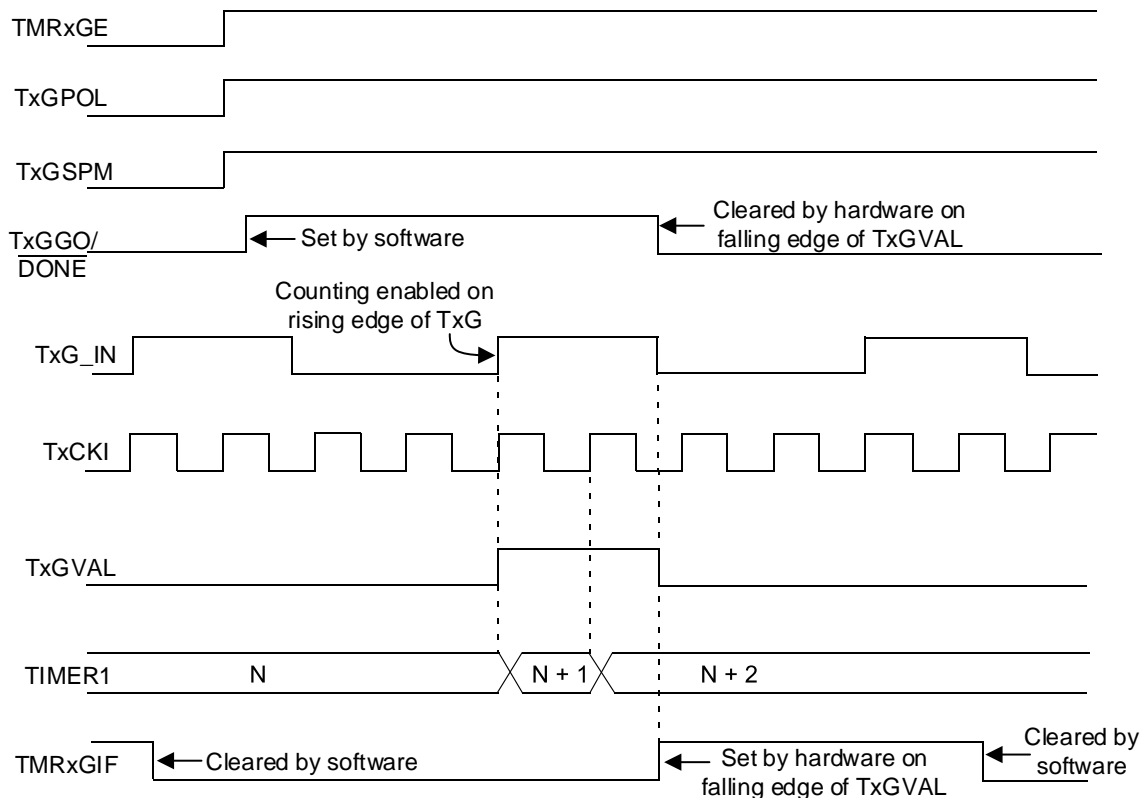

Clearing the GSPM bit will also clear the GGO/DONE bit. See the figure below for timing details. Enabling the Toggle mode and the Single Pulse mode simultaneously will permit both sections to work together. This allows the cycle times on the Timer1 gate source to be measured. See the figure below for timing details.

Figure 23-7. Timer1 Gate Single Pulse and Toggle Combined Mode

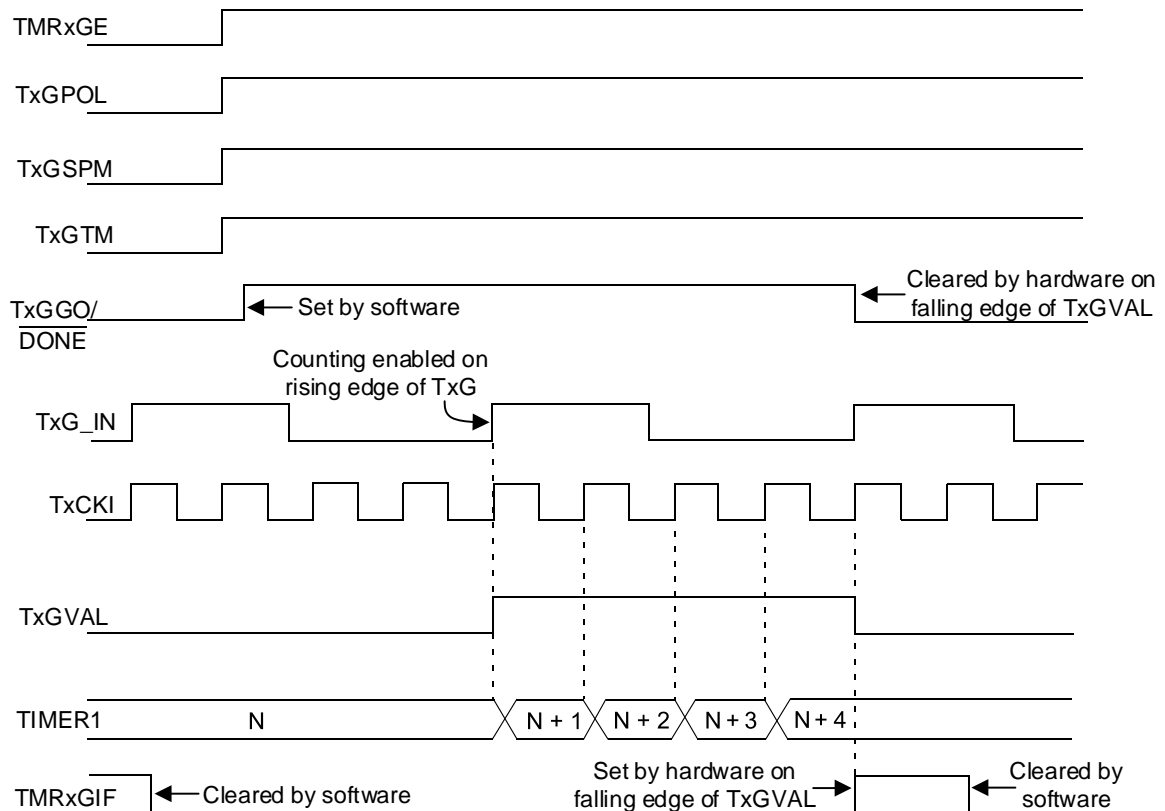

23.7.5 Timer1 Gate Value Status

When Timer1 gate value status is utilized, it is possible to read the most current level of the gate control value. The value is stored in the GVAL bit in the TxGCON register. The GVAL bit is valid even when the Timer1 gate is not enabled (GE bit is cleared).

23.7.6 Timer1 Gate Event Interrupt

When Timer1 gate event interrupt is enabled, it is possible to generate an interrupt upon the completion of a gate event. When the falling edge of GVAL occurs, the TMRxGIF flag bit in one of the PIR registers will be set. If the TMRxGIE bit in the corresponding PIE register is set, then an interrupt will be recognized.

The TMRxGIF flag bit operates even when the Timer1 gate is not enabled (the GE bit is cleared).

23.8 Timer1 Interrupt

The TMRx register increments to FFFFh and rolls over to 0000h. When TMRx rolls over, the Timer1 interrupt flag bit of the PIRx register is set. To enable the interrupt-on-rollover, the following bits must be set:

- The ON bit of the TxCON register
- The TMRxIE bits of the PIRx register
- Global interrupts must be enabled

The interrupt is cleared by clearing the TMRxIF bit as a task in the Interrupt Service Routine.



Important: The TMRx register and the TMRxIF bit must be cleared before enabling interrupts.

23.9 Timer1 Operation During Sleep

Timer1 can only operate during Sleep when configured as an asynchronous counter. In this mode, many clock sources can be used to increment the counter. To set up the timer to wake the device:

- The **ON** bit must be set
- The TMRxIE bit of the PEx register must be set
- Global interrupts must be enabled
- The **SYNC** bit must be set
- Configure the **TxCLK** register for using any clock source other than F_{OSC} and $F_{OSC}/4$

The device will wake up on an overflow and execute the next instruction. If global interrupts are enabled, the device will call the IRS. The secondary oscillator will continue to operate in Sleep regardless of the **SYNC** bit setting.

23.10 CCP Capture/Compare Time Base

The CCP modules use **TMRx** as the time base when operating in Capture or Compare mode. In Capture mode, the value in TMRx is copied into the CCPRx register on a capture event. In Compare mode, an event is triggered when the value in the CCPRx register matches the value in TMRx. This event can be a Special Event Trigger.

23.11 CCP Special Event Trigger

When any of the CCPs are configured to trigger a special event, the trigger will clear the TMRx register. This special event does not cause a Timer1 interrupt. The CCP module may still be configured to generate a CCP interrupt. In this mode of operation, the CCPRx register becomes the period register for Timer1. Timer1 must be synchronized and $F_{OSC}/4$ must be selected as the clock source to utilize the Special Event Trigger. Asynchronous operation of Timer1 can cause a Special Event Trigger to be missed. In the event that a write to TMRxH or TMRxL coincides with a Special Event Trigger from the CCP, the write will take precedence.

23.12 Peripheral Module Disable

When a peripheral is not used or inactive, the module can be disabled by setting the Module Disable bit in the PMD registers. This will reduce power consumption to an absolute minimum. Setting the PMD bits holds the module in Reset and disconnects the module's clock source. The Module Disable bits for Timer1 (TMR1MD) are in the PMDx register. See the **"PMD - Peripheral Module Disable"** chapter for more information.

23.13 Register Definitions: Timer1 Control

Long bit name prefixes for the Timer registers are shown in the table below, where 'x' refers to the Timer instance number. Refer to the **"Long Bit Names"** section in the **"Register and Bit Naming Conventions"** chapter for more information.

Table 23-3. Timer1 Register Long Bit Name Prefixes

Peripheral	Bit Name Prefix
Timer1	T1
Timer3	T3

23.13.1 TxCON

Name: TxCON
Offset: 0x030E,0x0314

Timer Control Register

Bit	7	6	5	4	3	2	1	0
			CKPS[1:0]			SYNC	RD16	ON
Access			R/W	R/W		R/W	R/W	R/W
Reset			0	0		0	0	0

Bits 5:4 – CKPS[1:0] Timer Input Clock Prescaler Select

Reset States: POR/BOR = 00

All Other Resets = uu

Value	Description
11	1:8 Prescaler value
10	1:4 Prescaler value
01	1:2 Prescaler value
00	1:1 Prescaler value

Bit 2 – SYNC Timer External Clock Input Synchronization Control

Reset States: POR/BOR = 0

All Other Resets = u

Value	Condition	Description
x	$CS = F_{osc}/4$ or F_{osc}	This bit is ignored. Timer uses the incoming clock as is.
1	All other clock sources	Do not synchronize external clock input
0	All other clock sources	Synchronize external clock input with system clock

Bit 1 – RD16 16-Bit Read/Write Mode Enable

Reset States: POR/BOR = 0

All Other Resets = u

Value	Description
1	Enables register read/write of Timer in one 16-bit operation
0	Enables register read/write of Timer in two 8-bit operations

Bit 0 – ON Timer On

Reset States: POR/BOR = 0

All Other Resets = u

Value	Description
1	Enables Timer
0	Disables Timer

23.13.2 TxGCON

Name: TxGCON
Offset: 0x030F,0x0315

Timer Gate Control Register

Bit	7	6	5	4	3	2	1	0
	GE	GPOL	GTM	GSPM	GGO/DONE	GVAL		
Access	R/W	R/W	R/W	R/W	R/W	R		
Reset	0	0	0	0	0	x		

Bit 7 – GE Timer Gate Enable

Reset States: POR/BOR = 0

All Other Resets = u

Value	Condition	Description
1	ON = 1	Timer counting is controlled by the Timer gate function
0	ON = 1	Timer is always counting
x	ON = 0	This bit is ignored

Bit 6 – GPOL Timer Gate Polarity

Reset States: POR/BOR = 0

All Other Resets = u

Value	Description
1	Timer gate is active-high (Timer counts when gate is high)
0	Timer gate is active-low (Timer counts when gate is low)

Bit 5 – GTM Timer Gate Toggle Mode

Timer Gate flip-flop toggles on every rising edge when Toggle mode is enabled.

Reset States: POR/BOR = 0

All Other Resets = u

Value	Description
1	Timer Gate Toggle mode is enabled
0	Timer Gate Toggle mode is disabled and Toggle flip-flop is cleared

Bit 4 – GSPM Timer Gate Single Pulse Mode

Reset States: POR/BOR = 0

All Other Resets = u

Value	Description
1	Timer Gate Single Pulse mode is enabled and is controlling Timer gate
0	Timer Gate Single Pulse mode is disabled

Bit 3 – GGO/DONE Timer Gate Single Pulse Acquisition Status

This bit is automatically cleared when TxGSPM is cleared.

Reset States: POR/BOR = 0

All Other Resets = u

Value	Description
1	Timer Gate Single Pulse Acquisition is ready, waiting for an edge
0	Timer Gate Single Pulse Acquisition has completed or has not been started

Bit 2 – GVAL Timer Gate Current State

Indicates the current state of the timer gate that can be provided to TMRxH:TMRxL

Unaffected by the Timer Gate Enable (GE) bit

23.13.3 TxCLK

Name: TxCLK
Offset: 0x0311,0x0317

Timer Clock Source Selection Register

Bit	7	6	5	4	3	2	1	0
				CS[4:0]				
Access				R/W	R/W	R/W	R/W	R/W
Reset				0	0	0	0	0

Bits 4:0 – CS[4:0] Timer Clock Source Selection

Table 23-4. Timer Clock Sources

CS	Clock Source	
	Timer1	Timer3
11111-10010	Reserved	
10001	CLC4_OUT	
10000	CLC3_OUT	
01111	CLC2_OUT	
01110	CLC1_OUT	
01101	TMR3_overflow_OUT	Reserved
01100	Reserved	TMR1_overflow_OUT
01011	TMR0_overflow_OUT	
01010	CLKR	
01001	EXTOSC	
01000	SOSC	
00111	MFINTOSC (32 kHz)	
00110	MFINTOSC (500 kHz)	
00101	SFINTOSC (1 MHz)	
00100	LFINTOSC	
00011	HFINTOSC	
00010	Fosc	
00001	Fosc/4	
00000	Pin selected by T1CKIPPS	Pin selected by T3CKIPPS

Reset States: POR/BOR = 00000
 All Other Resets = uuuuu

23.13.4 TxGATE

Name: TxGATE
Offset: 0x0310,0x0316

Timer Gate Source Selection Register

Bit	7	6	5	4	3	2	1	0
				GSS[4:0]				
Access				R/W	R/W	R/W	R/W	R/W
Reset				0	0	0	0	0

Bits 4:0 – GSS[4:0] Timer Gate Source Selection

Table 23-5. Timer Gate Sources

GSS	Gate Source	
	Timer1	Timer3
11111-11001	Reserved	
11000	CLC4_OUT	
10111	CLC3_OUT	
10110	CLC2_OUT	
10101	CLC1_OUT	
10100	ZCD_OUT	
10011	C2_OUT	
10010	C1_OUT	
10001	NCO1_OUT	
10000-01101	Reserved	
01100	PWM2S1P2_OUT	
01011	PWM2S1P1_OUT	
01010	PWM1S1P2_OUT	
01001	PWM1S1P1_OUT	
01000	CCP2_OUT	
00111	CCP1_OUT	
00110	Reserved	
00101	TMR4_Postscaled_OUT	
00100	TMR3_overflow_OUT	Reserved
00011	TMR2_Postscaled_OUT	
00010	Reserved	TMR1_overflow_OUT
00001	TMR0_overflow_OUT	
00000	Pin selected by T1GPPS	Pin selected by T3GPPS

23.13.5 TMRx

Name: TMRx
Offset: 0x030C,0x0312

Timer Register

Bit	15	14	13	12	11	10	9	8
	TMRx[15:8]							
Access	R/W	R/W	R/W	R/W	R/W	R/W	R/W	R/W
Reset	0	0	0	0	0	0	0	0
Bit	7	6	5	4	3	2	1	0
	TMRx[7:0]							
Access	R/W	R/W	R/W	R/W	R/W	R/W	R/W	R/W
Reset	0	0	0	0	0	0	0	0

Bits 15:0 – TMRx[15:0] Timer Register Value

Reset States: POR/BOR = 0000000000000000

All Other Resets = uuuuuuuuuuuuuuuuuuu

Notes: The individual bytes in this multibyte register can be accessed with the following register names:

- TMRxH: Accesses the high byte TMRx[15:8]
- TMRxL: Accesses the low byte TMRx[7:0]

23.14 Register Summary - Timer1

Offset	Name	Bit Pos.	7	6	5	4	3	2	1	0
0x00 ... 0x030B	Reserved									
0x030C	TMR1	7:0	TMR1[7:0]							
		15:8	TMR1[15:8]							
0x030E	T1CON	7:0			CKPS[1:0]			SYNC	RD16	ON
0x030F	T1GCON	7:0	GE	GPOL	GTM	GSPM	GGO/DONE	GVAL		
0x0310	T1GATE	7:0						GSS[4:0]		
0x0311	T1CLK	7:0						CS[4:0]		
0x0312	TMR3	7:0	TMR3[7:0]							
		15:8	TMR3[15:8]							
0x0314	T3CON	7:0			CKPS[1:0]			SYNC	RD16	ON
0x0315	T3GCON	7:0	GE	GPOL	GTM	GSPM	GGO/DONE	GVAL		
0x0316	T3GATE	7:0						GSS[4:0]		
0x0317	T3CLK	7:0						CS[4:0]		

24. TMR2 - Timer2 Module

The Timer2 module is an 8-bit timer that incorporates the following features:

- 8-bit timer and period registers
- Readable and writable
- Software programmable prescaler (1:1 to 1:128)
- Software programmable postscaler (1:1 to 1:16)
- Interrupt on T2TMR match with T2PR
- One-shot operation
- Full asynchronous operation
- Includes Hardware Limit Timer (HLT)
- Alternate clock sources
- External timer Reset signal sources
- Configurable timer Reset operation

See the figure below for a block diagram of Timer2.



Important: References to module Timer2 apply to all the even numbered timers on this device (Timer2, Timer4, etc.).

Figure 24-1. Timer2 with Hardware Limit Timer (HLT) Block Diagram

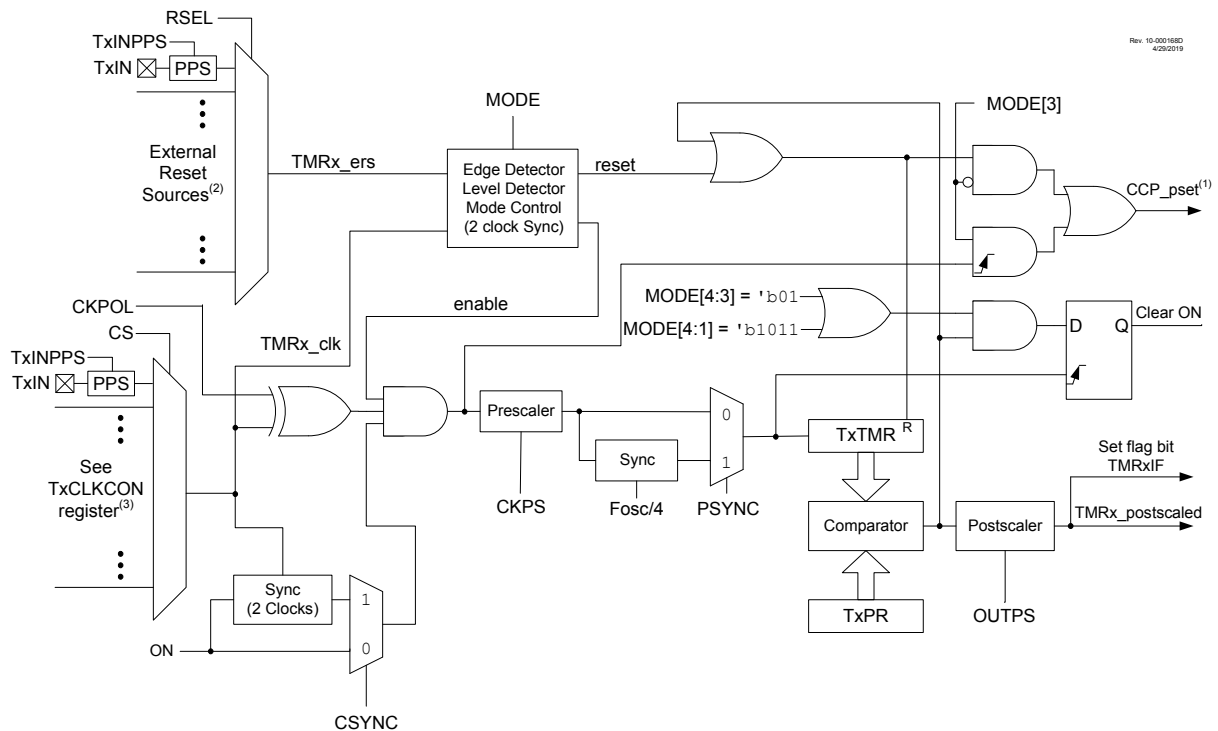

Notes:

1. Signal to the CCP peripheral for PWM pulse trigger in PWM mode.
2. See [RSEL](#) for external Reset sources.
3. See [CS](#) for clock source selections.

24.1 Timer2 Operation

Timer2 operates in three major modes:

- Free-Running Period
- One Shot
- Monostable

Within each operating mode, there are several options for starting, stopping and Reset. [Table 24-1](#) lists the options.

In all modes, the T2TMR count register increments on the rising edge of the clock signal from the programmable prescaler. When T2TMR equals T2PR, a high level output to the postscaler counter is generated. T2TMR is cleared on the next clock input.

An external signal from hardware can also be configured to gate the timer operation or force a T2TMR count Reset. In Gate modes, the counter stops when the gate is disabled and resumes when the gate is enabled. In Reset modes, the T2TMR count is reset on either the level or edge from the external source.

The T2TMR and T2PR registers are both directly readable and writable. The T2TMR register is cleared and the T2PR register initializes to 0xFF on any device Reset. Both the prescaler and postscaler counters are cleared on the following events:

- A write to the T2TMR register
- A write to the T2CON register
- Any device Reset
- External Reset source event that resets the timer



Important: T2TMR is not cleared when T2CON is written.

24.1.1 Free-Running Period Mode

The value of T2TMR is compared to that of the period register, T2PR, on each clock cycle. When the two values match, the comparator resets the value of T2TMR to 0x00 on the next cycle and increments the output postscaler counter. When the postscaler count equals the value in the [OUTPS](#) bits of the T2CON register, a one clock period wide pulse occurs on the TMR2_postscaled output, and the postscaler count is cleared.

24.1.2 One Shot Mode

The One Shot mode is identical to the Free-Running Period mode except that the ON bit is cleared and the timer is stopped when T2TMR matches T2PR and will not restart until the ON bit is cycled off and on. Postscaler (OUTPS) values other than zero are ignored in this mode because the timer is stopped at the first period event and the postscaler is reset when the timer is restarted.

24.1.3 Monostable Mode

Monostable modes are similar to One Shot modes except that the ON bit is not cleared and the timer can be restarted by an external Reset event.

24.2 Timer2 Output

The Timer2 module's primary output is TMR2_postscaled, which pulses for a single TMR2_clk period upon each match of the postscaler counter and the OUTPS bits of the T2CON register. The postscaler is incremented each time the T2TMR value matches the T2PR value. This signal can also be selected as an input to other Core Independent Peripherals.

In addition, the Timer2 is also used by the CCP module for pulse generation in PWM mode. See the "PWM Overview" and "PWM Period" sections in the "CCP - Capture/Compare/PWM Module" chapter for more details on setting up Timer2 for use with the CCP and PWM modules.

24.3 External Reset Sources

In addition to the clock source, the Timer2 can also be driven by an external Reset source input. This external Reset input is selected for each timer with the corresponding TxRST register. The external Reset input can control starting and stopping of the timer, as well as resetting the timer, depending on the mode used.

24.4 Timer2 Interrupt

Timer2 can also generate a device interrupt. The interrupt is generated when the postscaler counter matches the selected postscaler value (OUTPS bits of T2CON register). The interrupt is enabled by setting the TMR2IE interrupt enable bit. Interrupt timing is illustrated in the figure below.

Figure 24-2. Timer2 Prescaler, Postscaler, and Interrupt Timing Diagram

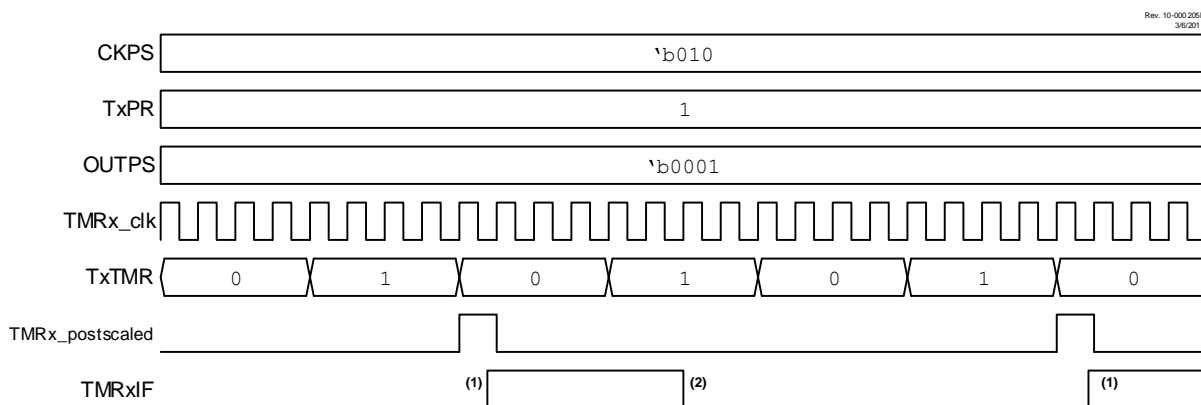

- Notes:**
- Setting the interrupt flag is synchronized with the instruction clock. Synchronization may take as many as two instruction cycles.
 - Cleared by software.

24.5 PSYNC Bit

Setting the PSYNC bit synchronizes the prescaler output to $F_{OSC}/4$. Setting this bit is required for reading the Timer2 counter register while the selected Timer clock is asynchronous to $F_{OSC}/4$.

Note: Setting PSYNC requires that the output of the prescaler is slower than $F_{OSC}/4$. Setting PSYNC when the output of the prescaler is greater than or equal to $F_{OSC}/4$ may cause unexpected results.

24.6 CSYNC Bit

All bits in the Timer2 SFRs are synchronized to $F_{OSC}/4$ by default, not the Timer2 input clock. As such, if the Timer2 input clock is not synchronized to $F_{OSC}/4$, it is possible for the Timer2 input clock to transition at the same time as the ON bit is set in software, which may cause undesirable behavior and glitches in the counter. Setting the CSYNC bit remedies this problem by synchronizing the ON bit to the Timer2 input clock instead of $F_{OSC}/4$. However, as this synchronization uses an edge of the TMR2 input clock, up to one input clock cycle will be consumed and not counted by the Timer2 when

CSYNC is set. Conversely, clearing the CSYNC bit synchronizes the ON bit to $F_{OSC}/4$, which does not consume any clock edges, but has the previously stated risk of glitches.

24.7 Operating Modes

The mode of the timer is controlled by the **MODE** bits. Edge Triggered modes require six Timer clock periods between external triggers. Level Triggered modes require the triggering level to be at least three Timer clock periods long. External triggers are ignored while in Debug mode.

Table 24-1. Operating Modes Table

Mode	MODE		Output Operation	Operation	Timer Control		
	[4:3]	[2:0]			Start	Reset	Stop
Free-Running Period	00	000	Period Pulse	Software gate (Figure 24-3)	ON = 1	—	ON = 0
		001		Hardware gate, active-high (Figure 24-4)	ON = 1 and TMRx_ers = 1	—	ON = 0 or TMRx_ers = 0
		010		Hardware gate, active-low	ON = 1 and TMRx_ers = 0	—	ON = 0 or TMRx_ers = 1
		011	Period Pulse with Hardware Reset	Rising or falling edge Reset	ON = 1	TMRx_ers ↓	ON = 0
		100		Rising edge Reset (Figure 24-5)		TMRx_ers ↑	
		101		Falling edge Reset		TMRx_ers ↓	
		110		Low-level Reset		TMRx_ers = 0	ON = 0 or TMRx_ers = 0
		111		High-level Reset (Figure 24-6)		TMRx_ers = 1	ON = 0 or TMRx_ers = 1
One Shot	01	000	One-shot	Software start (Figure 24-7)	ON = 1	—	ON = 0 or Next clock after TxTMR = TxPR (Note 2)
		001	Edge-Triggered Start (Note 1)	Rising edge start (Figure 24-8)	ON = 1 and TMRx_ers ↑	—	
		010		Falling edge start	ON = 1 and TMRx_ers ↓	—	
		011		Any edge start	ON = 1 and TMRx_ers ↓	—	
		100	Edge-Triggered Start and Hardware Reset (Note 1)	Rising edge start and Rising edge Reset (Figure 24-9)	ON = 1 and TMRx_ers ↑	TMRx_ers ↑	
		101		Falling edge start and Falling edge Reset	ON = 1 and TMRx_ers ↓	TMRx_ers ↓	
		110		Rising edge start and Low-level Reset (Figure 24-10)	ON = 1 and TMRx_ers ↑	TMRx_ers = 0	
		111		Falling edge start and High-level Reset	ON = 1 and TMRx_ers ↓	TMRx_ers = 1	

.....continued

Mode	MODE		Output Operation	Operation	Timer Control		
	[4:3]	[2:0]			Start	Reset	Stop
Monostable	10	000	Reserved				
		001	Edge-Triggered Start (Note 1)	Rising edge start (Figure 24-11)	ON = 1 and TMRx_ers ↑	—	ON = 0 or Next clock after TxTMR = TxPR
		010		Falling edge start	ON = 1 and TMRx_ers ↓	—	(Note 3)
		011		Any edge start	ON = 1 and TMRx_ers ↓↑	—	
Reserved	100	Reserved					
Reserved	101	Reserved					
One Shot	11	110	Level-Triggered Start and Hardware Reset	High-level start and Low-level Reset (Figure 24-12)	ON = 1 and TMRx_ers = 1	TMRx_ers = 0	ON = 0 or Held in Reset (Note 2)
		111		Low-level start and High-level Reset	ON = 1 and TMRx_ers = 0	TMRx_ers = 1	
Reserved	11	xxx	Reserved				

Notes:

1. If ON = 0, then an edge is required to restart the timer after ON = 1.
2. When T2TMR = T2PR, the next clock clears ON and stops T2TMR at 00h.
3. When T2TMR = T2PR, the next clock stops T2TMR at 00h but does not clear ON.

24.8 Operation Examples

Unless otherwise specified, the following notes apply to the following timing diagrams:

- Both the prescaler and postscaler are set to 1:1 (both the CKPS and OUTPS bits).
- The diagrams illustrate any clock except F_{OSC}/4 and show clock-sync delays of at least two full cycles for both ON and TMRx_ers. When using F_{OSC}/4, the clock-sync delay is at least one instruction period for TMRx_ers; ON applies in the next instruction period.
- ON and TMRx_ers are somewhat generalized, and clock-sync delays may produce results that are slightly different than illustrated.
- The PWM Duty Cycle and PWM output are illustrated assuming that the timer is used for the PWM function of the CCP module as described in the “**PWM Overview**” section in the “**CCP - Capture/Compare/PWM Module**” chapter. The signals are not a part of the Timer2 module.

24.8.1 Software Gate Mode

This mode corresponds to legacy Timer2 operation. The timer increments with each clock input when ON = 1 and does not increment when ON = 0. When the TxTMR count equals the TxPR period count, the timer resets on the next clock and continues counting from zero. Operation with the ON bit software controlled is illustrated in Figure 24-3. With TxPR = 5, the counter advances until TxTMR = 5 and goes to zero with the next clock.

Figure 24-3. Software Gate Mode Timing Diagram (MODE = 'b00000)

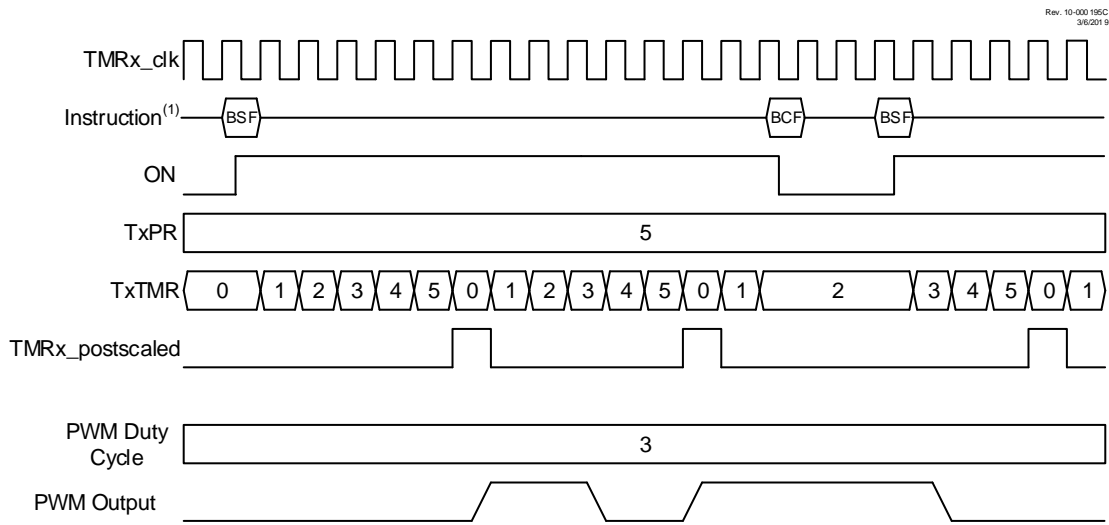

Note: 1. BSF and BCF represent Bit-Set File and Bit-Clear File instructions executed by the CPU to set or clear the ON bit of TxCON. CPU execution is asynchronous to the timer clock input.

24.8.2 Hardware Gate Mode

The Hardware Gate modes operate the same as the Software Gate mode, except the TMRx_ers external signal can also gate the timer. When used with the CCP, the gating extends the PWM period. If the timer is stopped when the PWM output is high, then the duty cycle is also extended.

When MODE = 'b00001, then the timer is stopped when the external signal is high. When MODE = 'b00010, then the timer is stopped when the external signal is low.

Figure 24-4 illustrates the Hardware Gating mode for MODE = 'b00001 in which a high input level starts the counter.

Figure 24-4. Hardware Gate Mode Timing Diagram (MODE = 'b00001)

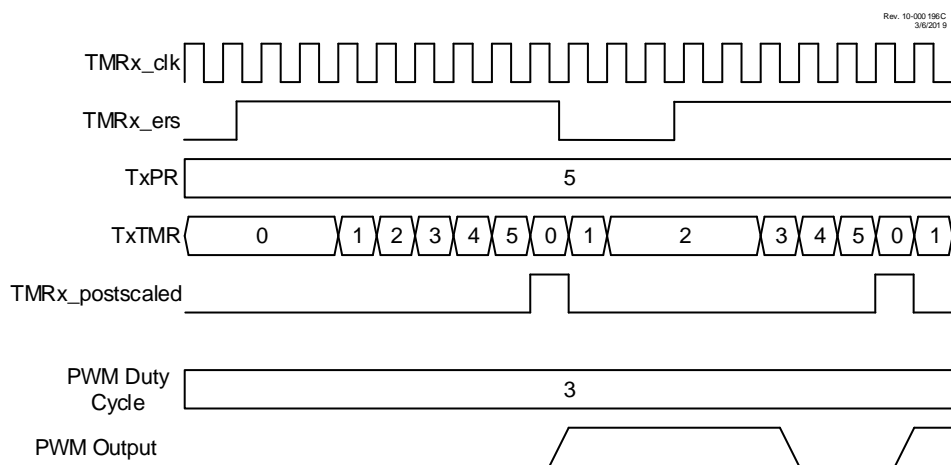

24.8.3 Edge Triggered Hardware Limit Mode

In Hardware Limit mode, the timer can be reset by the TMRx_ers external signal before the timer reaches the period count. Three types of Resets are possible:

- Reset on rising or falling edge (MODE = `b00011)
- Reset on rising edge (MODE = `b00100)
- Reset on falling edge (MODE = `b00101)

When the timer is used in conjunction with the CCP in PWM mode then an early Reset shortens the period and restarts the PWM pulse after a two clock delay. Refer to [Figure 24-5](#).

Figure 24-5. Edge Triggered Hardware Limit Mode Timing Diagram (MODE = `b00100)

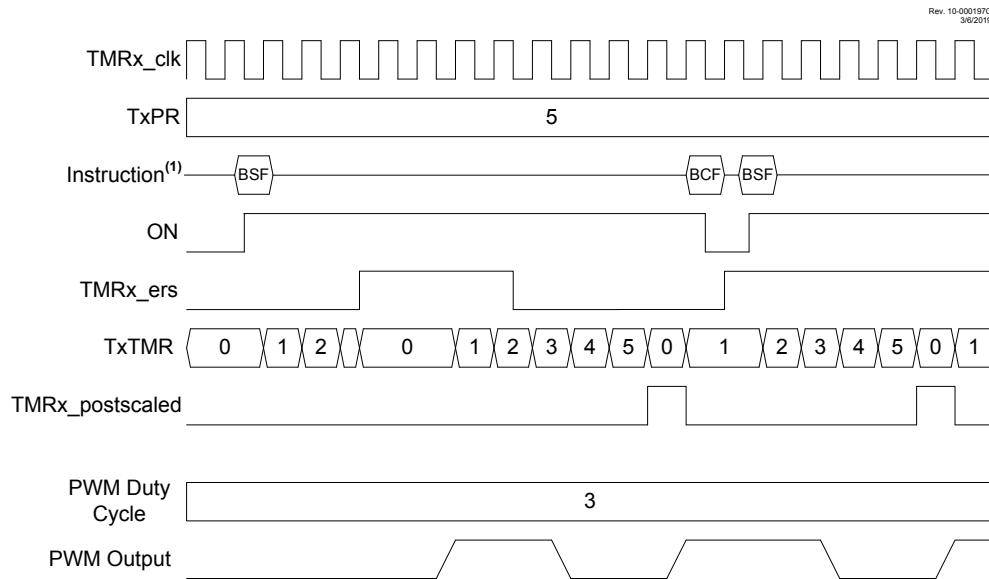

Note: 1. BSF and BCF represent Bit-Set File and Bit-Clear File instructions executed by the CPU to set or clear the ON bit of TxCON. CPU execution is asynchronous to the timer clock input.

24.8.4 Level Triggered Hardware Limit Mode

In the Level Triggered Hardware Limit Timer modes the counter is reset by high or low levels of the external signal TMRx_ers, as shown in Figure 24-6. Selecting MODE = 'b00110 will cause the timer to reset on a low-level external signal. Selecting MODE = 'b00111 will cause the timer to reset on a high-level external signal. In the example, the counter is reset while TMRx_ers = 1. ON is controlled by BSF and BCF instructions. When ON = 0, the external signal is ignored.

When the CCP uses the timer as the PWM time base, then the PWM output will be set high when the timer starts counting and then set low only when the timer count matches the CCPRx value. The timer is reset when either the timer count matches the TxPR value or two clock periods after the external Reset signal goes true and stays true.

The timer starts counting, and the PWM output is set high on either the clock following the TxPR match or two clocks after the external Reset signal relinquishes the Reset. The PWM output will remain high until the timer counts up to match the CCPRx pulse-width value. If the external Reset signal goes true while the PWM output is high, then the PWM output will remain high until the Reset signal is released allowing the timer to count up to match the CCPRx value.

Figure 24-6. Level Triggered Hardware Limit Mode Timing Diagram (MODE = 'b00111)

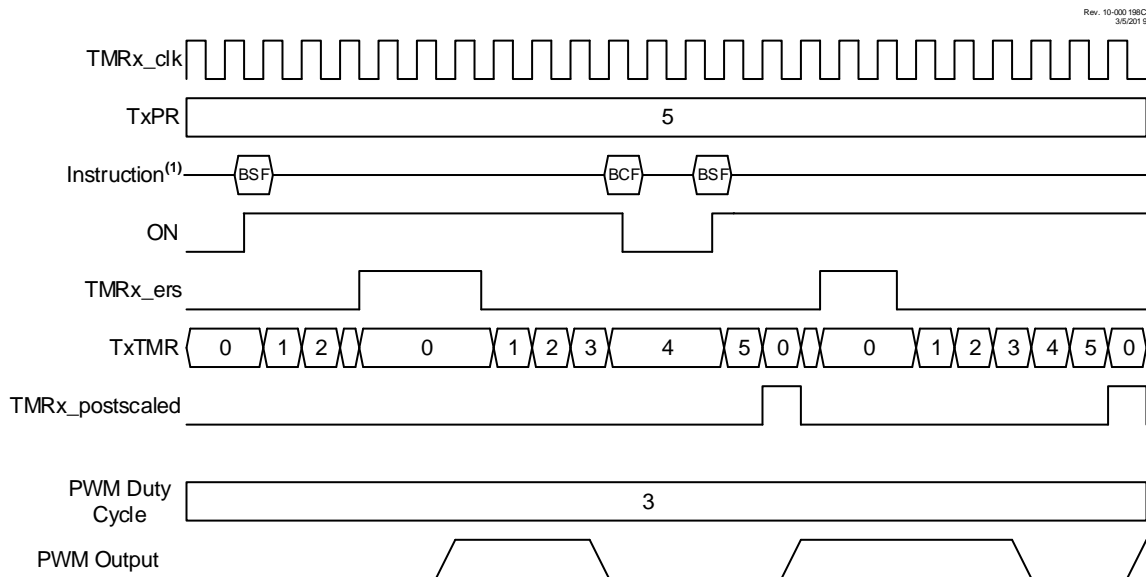

Note: 1. BSF and BCF represent Bit-Set File and Bit-Clear File instructions executed by the CPU to set or clear the ON bit of TxCON. CPU execution is asynchronous to the timer clock input.

24.8.5 Software Start One Shot Mode

In One Shot mode, the timer resets and the ON bit is cleared when the timer value matches the TxPR period value. The ON bit must be set by software to start another timer cycle. Setting MODE = 'b01000 selects One Shot mode which is illustrated in Figure 24-7. In the example, ON is controlled by BSF and BCF instructions. In the first case, a BSF instruction sets ON and the counter runs to completion and clears ON. In the second case, a BSF instruction starts the cycle, the BCF/BSF instructions turn the counter off and on during the cycle, and then it runs to completion.

When One Shot mode is used in conjunction with the CCP PWM operation, the PWM pulse drive starts concurrent with setting the ON bit. Clearing the ON bit while the PWM drive is active will extend the PWM drive. The PWM drive will terminate when the timer value matches the CCPRx pulse-width value. The PWM drive will remain off until the software sets the ON bit to start another cycle. If the software clears the ON bit after the CCPRx match but before the TxPR match, then the PWM drive will be extended by the length of time the ON bit remains cleared. Another timing cycle can only be initiated by setting the ON bit after it has been cleared by a TxPR period count match.

Figure 24-7. Software Start One Shot Mode Timing Diagram (MODE = 'b01000)

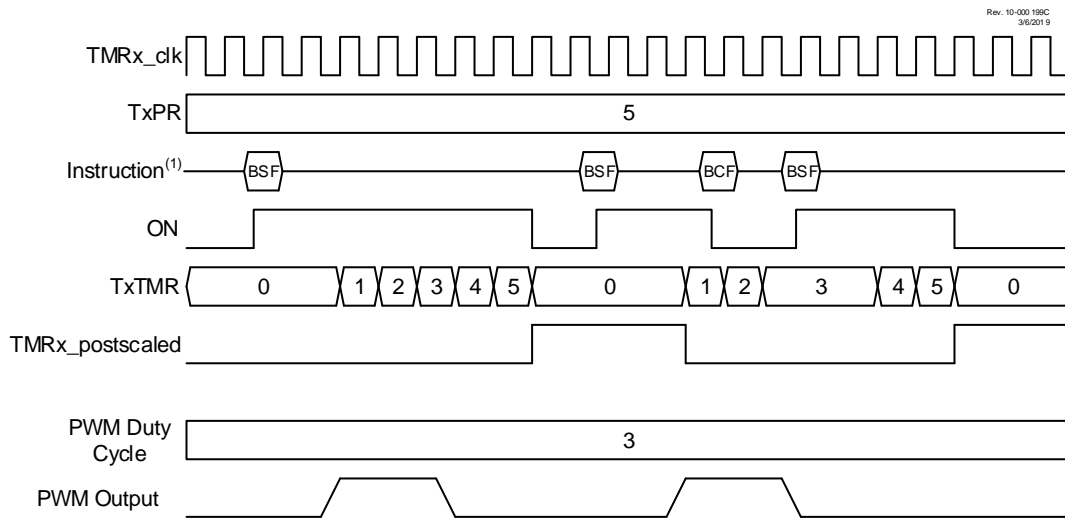

Note: 1. BSF and BCF represent Bit-Set File and Bit-Clear File instructions executed by the CPU to set or clear the ON bit of TxCON. CPU execution is asynchronous to the timer clock input.

24.8.6 Edge Triggered One Shot Mode

The Edge Triggered One Shot modes start the timer on an edge from the external signal input after the ON bit is set and clear the ON bit when the timer matches the TxPR period value. The following edges will start the timer:

- Rising edge (MODE = `b01001)
- Falling edge (MODE = `b01010)
- Rising or Falling edge (MODE = `b01011)

If the timer is halted by clearing the ON bit, then another TMRx_ers edge is required after the ON bit is set to resume counting. [Figure 24-8](#) illustrates operation in the rising edge One Shot mode.

When Edge Triggered One Shot mode is used in conjunction with the CCP, then the edge-trigger will activate the PWM drive and the PWM drive will deactivate when the timer matches the CCPRx pulse-width value and stay deactivated when the timer halts at the TxPR period count match.

Figure 24-8. Edge Triggered One Shot Mode Timing Diagram (MODE = `b01001)

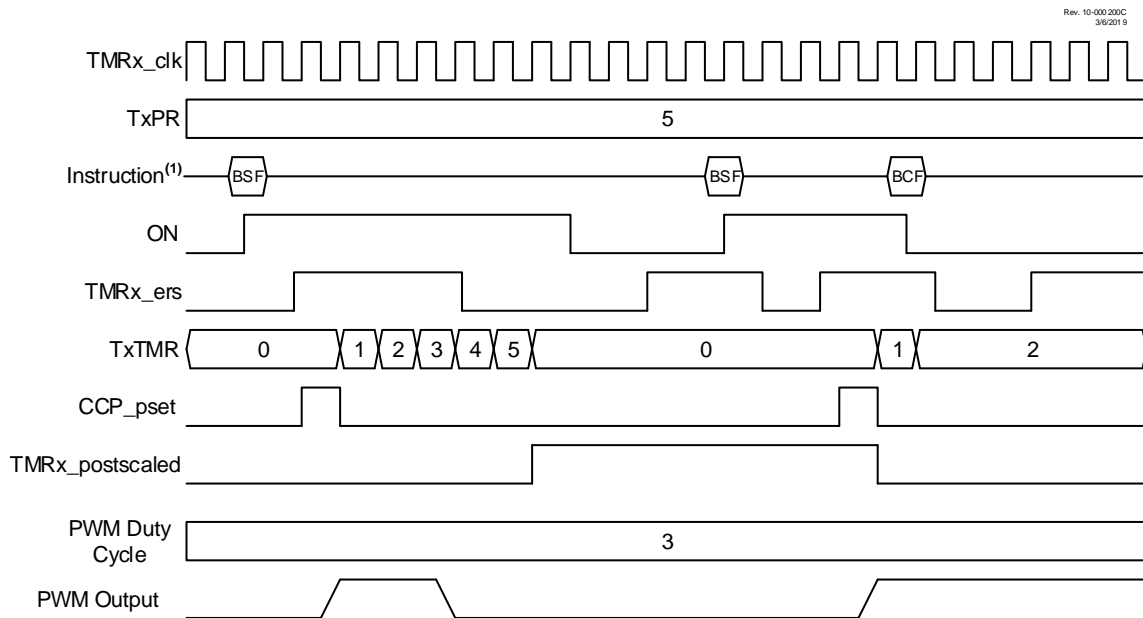

Note: 1. BSF and BCF represent Bit-Set File and Bit-Clear File instructions executed by the CPU to set or clear the ON bit of TxCON. CPU execution is asynchronous to the timer clock input.

24.8.7 Edge Triggered Hardware Limit One Shot Mode

In Edge Triggered Hardware Limit One Shot modes, the timer starts on the first external signal edge after the ON bit is set and resets on all subsequent edges. Only the first edge after the ON bit is set is needed to start the timer. The counter will resume counting automatically two clocks after all subsequent external Reset edges. Edge triggers are as follows:

- Rising edge start and Reset (MODE = 'b01100)
- Falling edge start and Reset (MODE = 'b01101)

The timer resets and clears the ON bit when the timer value matches the TxPR period value. External signal edges will have no effect until after software sets the ON bit. Figure 24-9 illustrates the rising edge hardware limit one-shot operation.

When this mode is used in conjunction with the CCP, the first starting edge trigger and all subsequent Reset edges will activate the PWM drive. The PWM drive will deactivate when the timer matches the CCPRx pulse-width value and stay deactivated until the timer halts at the TxPR period match unless an external signal edge resets the timer before the match occurs.

Figure 24-9. Edge Triggered Hardware Limit One Shot Mode Timing Diagram (MODE = 'b01100)

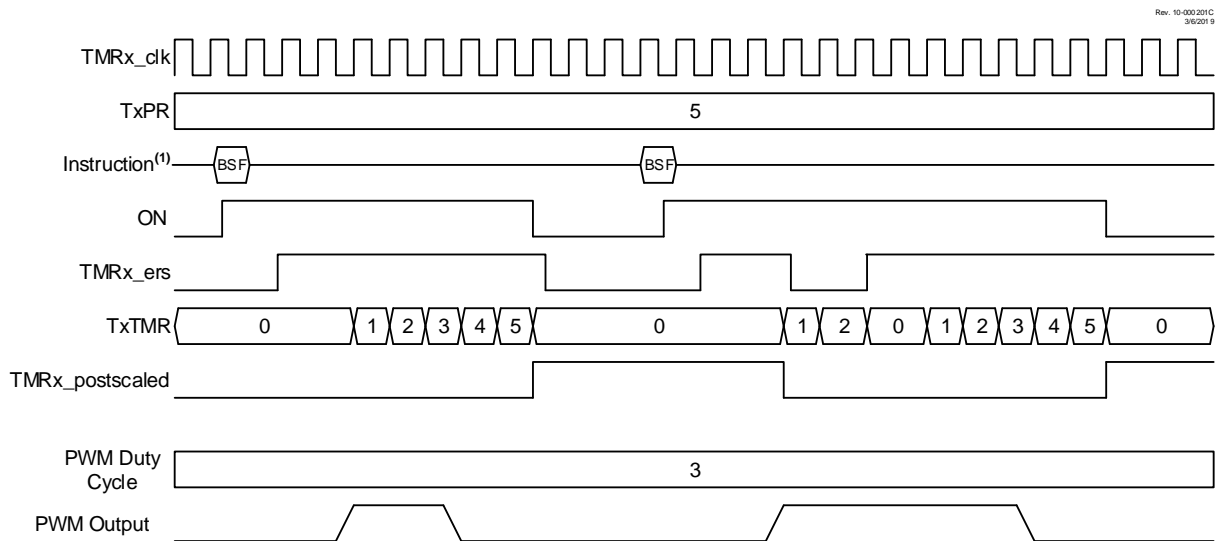

Note: 1. BSF and BCF represent Bit-Set File and Bit-Clear File instructions executed by the CPU to set or clear the ON bit of TxCON. CPU execution is asynchronous to the timer clock input.

24.8.8 Level Reset, Edge Triggered Hardware Limit One Shot Modes

In Level Triggered One Shot mode, the timer count is reset on the external signal level and starts counting on the rising/falling edge of the transition from Reset level to the active level while the ON bit is set. Reset levels are selected as follows:

- Low Reset level (MODE = `'b01110`)
- High Reset level (MODE = `'b01111`)

When the timer count matches the TxPR period count, the timer is reset and the ON bit is cleared. When the ON bit is cleared by either a TxPR match or by software control, a new external signal edge is required after the ON bit is set to start the counter.

When Level-Triggered Reset One Shot mode is used in conjunction with the CCP PWM operation, the PWM drive goes active with the external signal edge that starts the timer. The PWM drive goes inactive when the timer count equals the CCPRx pulse-width count. The PWM drive does not go active when the timer count clears at the TxPR period count match.

Figure 24-10. Low Level Reset, Edge Triggered Hardware Limit One Shot Mode Timing Diagram (MODE = `'b01110`)

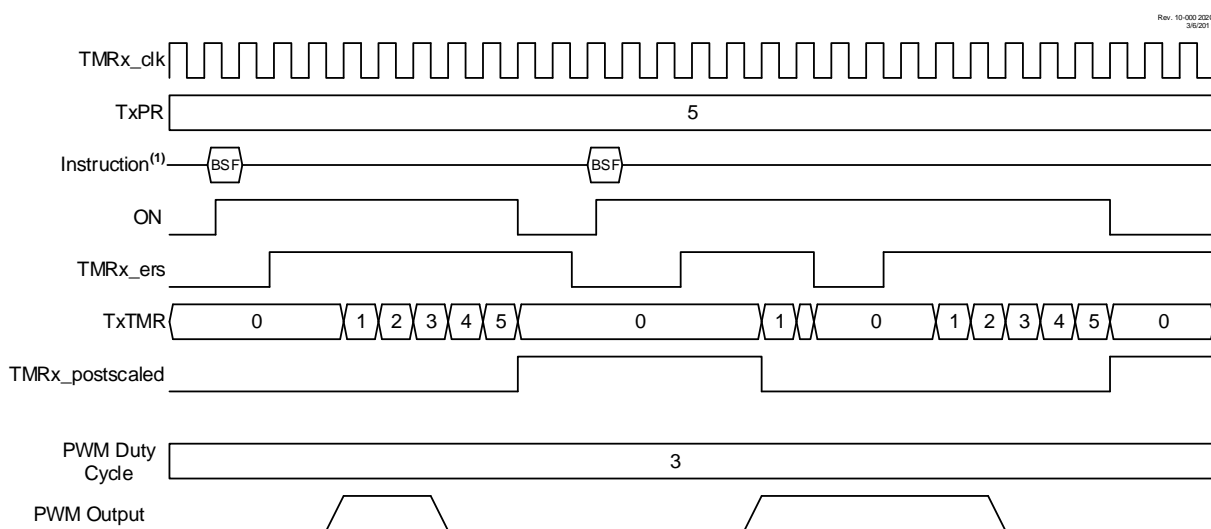

Note: 1. BSF and BCF represent Bit-Set File and Bit-Clear File instructions executed by the CPU to set or clear the ON bit of TxCON. CPU execution is asynchronous to the timer clock input.

24.8.9 Edge Triggered Monostable Modes

The Edge Triggered Monostable modes start the timer on an edge from the external Reset signal input after the ON bit is set and stop incrementing the timer when the timer matches the TxPR period value. The following edges will start the timer:

- Rising edge (MODE = `'b10001`)
- Falling edge (MODE = `'b10010`)
- Rising or Falling edge (MODE = `'b10011`)

When an Edge Triggered Monostable mode is used in conjunction with the CCP PWM operation, the PWM drive goes active with the external Reset signal edge that starts the timer, but will not go active when the timer matches the TxPR value. While the timer is incrementing, additional edges on the external Reset signal will not affect the CCP PWM.

Figure 24-11. Rising Edge Triggered Monostable Mode Timing Diagram (MODE = 'b10001)

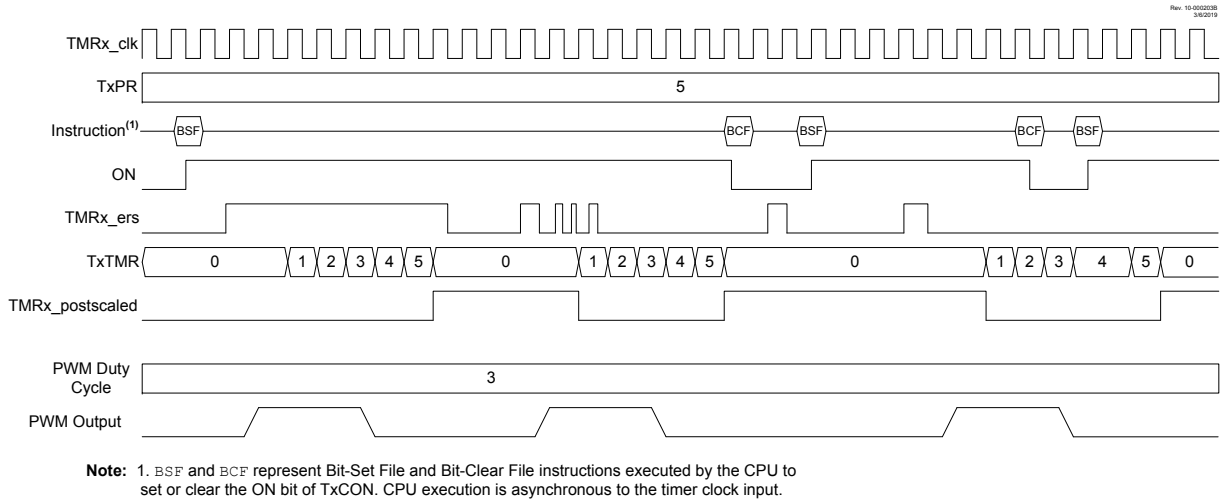

24.8.10 Level Triggered Hardware Limit One Shot Modes

The Level Triggered Hardware Limit One Shot modes hold the timer in Reset on an external Reset level and start counting when both the ON bit is set and the external signal is not at the Reset level. If one of either the external signal is not in Reset or the ON bit is set, then the other signal being set/made active will start the timer. Reset levels are selected as follows:

- Low Reset level (MODE = 'b10110)
- High Reset level (MODE = 'b10111)

When the timer count matches the TxPR period count, the timer is reset and the ON bit is cleared. When the ON bit is cleared by either a TxPR match or by software control, the timer will stay in Reset until both the ON bit is set and the external signal is not at the Reset level.

When Level Triggered Hardware Limit One Shot modes are used in conjunction with the CCP PWM operation, the PWM drive goes active with either the external signal edge or the setting of the ON bit, whichever of the two starts the timer.

Figure 24-12. Level Triggered Hardware Limit One Shot Mode Timing Diagram (MODE = 'b10110)

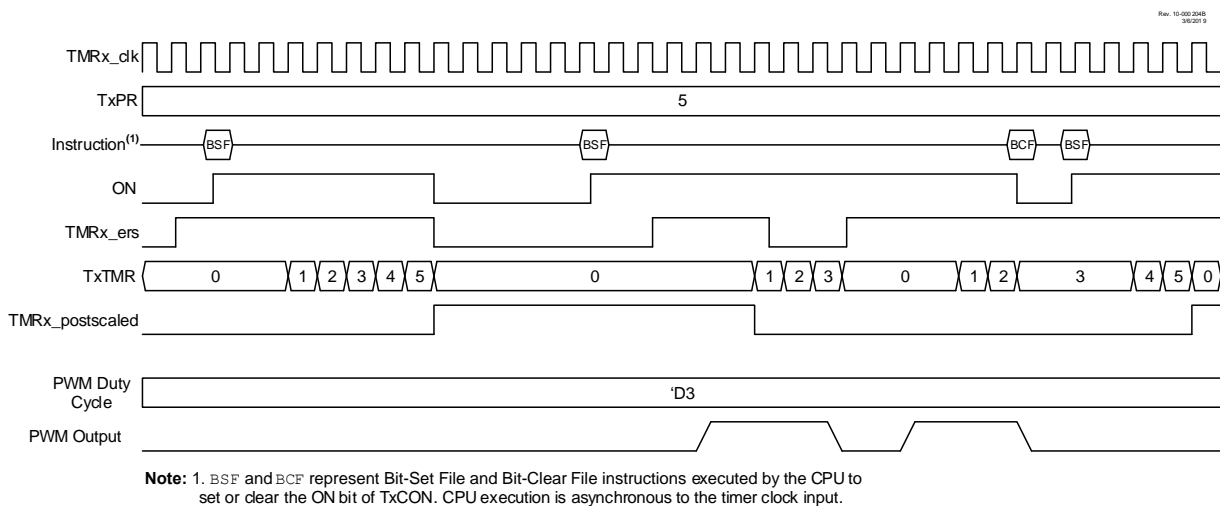

24.9 Timer2 Operation During Sleep

When **PSYNC** = 1, Timer2 cannot be operated while the processor is in Sleep mode. The contents of the T2TMR and T2PR registers will remain unchanged while the processor is in Sleep mode.

When **PSYNC** = 0, Timer2 will operate in Sleep as long as the clock source selected is also still running. If any internal oscillator is selected as the clock source, it will stay active during Sleep mode.

24.10 Register Definitions: Timer2 Control

Long bit name prefixes for the Timer2 peripherals are shown in the table below. Refer to the “**Long Bit Names**” section of the “**Register and Bit Naming Conventions**” chapter for more information.

Table 24-2. Timer2 Long Bit Name Prefixes

Peripheral	Bit Name Prefix
Timer2	T2
Timer4	T4



Important: References to module Timer2 apply to all the even numbered timers on this device (Timer2, Timer4, etc.).

24.10.1 TxTMR

Name: TxTMR
Offset: 0x038C,0x0392

Timer Counter Register

Bit	7	6	5	4	3	2	1	0
	TxTMR[7:0]							
Access	R/W	R/W	R/W	R/W	R/W	R/W	R/W	R/W
Reset	0	0	0	0	0	0	0	0

Bits 7:0 – TxTMR[7:0] Timerx Counter

24.10.2 TxPR

Name: TxPR
Offset: 0x038D,0x0393

Timer Period Register

Bit	7	6	5	4	3	2	1	0
	TxPR[7:0]							
Access	R/W	R/W	R/W	R/W	R/W	R/W	R/W	R/W
Reset	1	1	1	1	1	1	1	1

Bits 7:0 - TxPR[7:0] Timer Period Register

Value	Description
0 to 255	The timer restarts at '0' when TxTMR reaches the TxPR value

24.10.3 TxCON

Name: TxCON
Offset: 0x038E,0x0394

Timerx Control Register

Bit	7	6	5	4	3	2	1	0
	ON	CKPS[2:0]			OUTPS[3:0]			
Access	R/W/HC	R/W	R/W	R/W	R/W	R/W	R/W	R/W
Reset	0	0	0	0	0	0	0	0

Bit 7 – ON Timer On⁽¹⁾

Value	Description
1	Timer is on
0	Timer is off: All counters and state machines are reset

Bits 6:4 – CKPS[2:0] Timer Clock Prescale Select

Value	Description
111	1:128 Prescaler
110	1:64 Prescaler
101	1:32 Prescaler
100	1:16 Prescaler
011	1:8 Prescaler
010	1:4 Prescaler
001	1:2 Prescaler
000	1:1 Prescaler

Bits 3:0 – OUTPS[3:0] Timer Output Postscaler Select

Value	Description
1111	1:16 Postscaler
1110	1:15 Postscaler
1101	1:14 Postscaler
1100	1:13 Postscaler
1011	1:12 Postscaler
1010	1:11 Postscaler
1001	1:10 Postscaler
1000	1:9 Postscaler
0111	1:8 Postscaler
0110	1:7 Postscaler
0101	1:6 Postscaler
0100	1:5 Postscaler
0011	1:4 Postscaler
0010	1:3 Postscaler
0001	1:2 Postscaler
0000	1:1 Postscaler

Note:

1. In certain modes, the ON bit will be auto-cleared by hardware. See [Table 24-1](#).

24.10.4 TxHLT

Name: TxHLT
Offset: 0x038F,0x0395

Timer Hardware Limit Control Register

Bit	7	6	5	4	3	2	1	0
	PSYNC	CPOL	CSYNC	MODE[4:0]				
Access	R/W	R/W	R/W	R/W	R/W	R/W	R/W	R/W
Reset	0	0	0	0	0	0	0	0

Bit 7 – PSYNC Timer Prescaler Synchronization Enable^(1, 2)

Value	Description
1	Timer Prescaler Output is synchronized to $F_{OSC}/4$
0	Timer Prescaler Output is not synchronized to $F_{OSC}/4$

Bit 6 – CPOL Timer Clock Polarity Selection⁽³⁾

Value	Description
1	Falling edge of input clock clocks timer/prescaler
0	Rising edge of input clock clocks timer/prescaler

Bit 5 – CSYNC Timer Clock Synchronization Enable^(4, 5)

Value	Description
1	ON bit is synchronized to timer clock input
0	ON bit is not synchronized to timer clock input

Bits 4:0 – MODE[4:0] Timer Control Mode Selection^(6, 7)

Value	Description
00000 to 11111	See Table 24-1

Notes:

- Setting this bit ensures that reading TxTMR will return a valid data value.
- When this bit is '1', the Timer cannot operate in Sleep mode.
- CKPOL must not be changed while ON = 1.
- Setting this bit ensures glitch-free operation when the ON is enabled or disabled.
- When this bit is set, then the timer operation will be delayed by two input clocks after the ON bit is set.
- Unless otherwise indicated, all modes start upon ON = 1 and stop upon ON = 0 (stops occur without affecting the value of TxTMR).
- When TxTMR = TxPR, the next clock clears TxTMR, regardless of the operating mode.

24.10.5 TxCLKCON

Name: TxCLKCON
Offset: 0x0390,0x0396

Timer Clock Source Selection Register

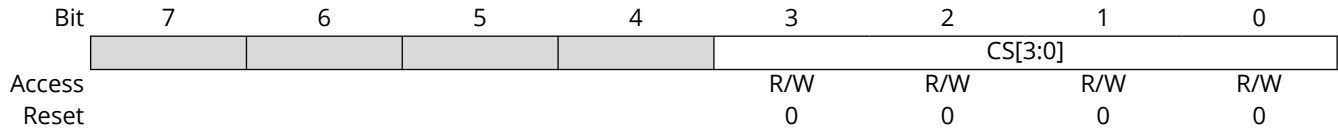

Bits 3:0 – CS[3:0] Timer Clock Source Selection

Table 24-3. Clock Source Selection

CS	Clock Source	
	Timer2	Timer4
1111		CLC4_OUT
1110		CLC3_OUT
1101		CLC2_OUT
1100		CLC1_OUT
1011		ZCD_OUT
1010		NCO1_OUT
1001		CLKR_OUT
1000		EXTOSC
0111		SOSC
0110		MFINTOSC (32 kHz)
0101		MFINTOSC (500 kHz)
0100		LFINTOSC
0011		HFINTOSC
0010		F _{osc}
0001		F _{osc} /4
0000	Pin selected by T2INPPS	Pin selected by T4INPPS

24.10.6 TxRST

Name: TxRST
Offset: 0x0391,0x0397

Timer External Reset Signal Selection Register

Bit	7	6	5	4	3	2	1	0
				RSEL[4:0]				
Access				R/W	R/W	R/W	R/W	R/W
Reset				0	0	0	0	0

Bits 4:0 – RSEL[4:0] External Reset Source Selection

Table 24-4. External Reset Sources

RSEL	Reset Source	
	TMR2	TMR4
11111-10101	Reserved	
10100	CLC4_OUT	
10011	CLC3_OUT	
10010	CLC2_OUT	
10001	CLC1_OUT	
10000	ZCD_OUT	
01111	C2_OUT	
01110	C1_OUT	
01101-01010	Reserved	
01001	PWM2S1P2_OUT	
01000	PWM2S1P1_OUT	
00111	PWM1S1P2_OUT	
00110	PWM1S1P1_OUT	
00101	CCP2_OUT	
00100	CCP1_OUT	
00011	Reserved	
00010	TMR4_Postscaled_OUT	Reserved
00001	Reserved	TMR2_Postscaled_OUT
00000	Pin selected by T2INPPS	Pin selected by T4INPPS

24.11 Register Summary - Timer2

Offset	Name	Bit Pos.	7	6	5	4	3	2	1	0
0x00	Reserved									
...										
0x038B										
0x038C	T2TMR	7:0	T2TMR[7:0]							
0x038D	T2PR	7:0	T2PR[7:0]							
0x038E	T2CON	7:0	ON	CKPS[2:0]			OUTPS[3:0]			
0x038F	T2HLT	7:0	PSYNC	CPOL	CSYNC	MODE[4:0]				
0x0390	T2CLKCON	7:0	CS[3:0]							
0x0391	T2RST	7:0	RSEL[4:0]							
0x0392	T4TMR	7:0	T4TMR[7:0]							
0x0393	T4PR	7:0	T4PR[7:0]							
0x0394	T4CON	7:0	ON	CKPS[2:0]			OUTPS[3:0]			
0x0395	T4HLT	7:0	PSYNC	CPOL	CSYNC	MODE[4:0]				
0x0396	T4CLKCON	7:0	CS[3:0]							
0x0397	T4RST	7:0	RSEL[4:0]							

25. NCO - Numerically Controlled Oscillator Module

The Numerically Controlled Oscillator (NCO) module is a timer that uses overflow from the addition of an increment value to divide the input frequency. The advantage of the addition method over a simple counter driven timer is that the output frequency resolution does not vary with the divider value. The NCO is most useful for applications that require frequency accuracy and fine resolution at a fixed duty cycle.

Features of the NCO include:

- 20-Bit Increment Function
- Fixed Duty Cycle (FDC) mode
- Pulse Frequency (PF) mode
- Output Pulse-Width Control
- Multiple Clock Input Sources
- Output Polarity Control
- Interrupt Capability

The following figure is a simplified block diagram of the NCO module.

Figure 25-1. Numerically Controlled Oscillator Module Simplified Block Diagram

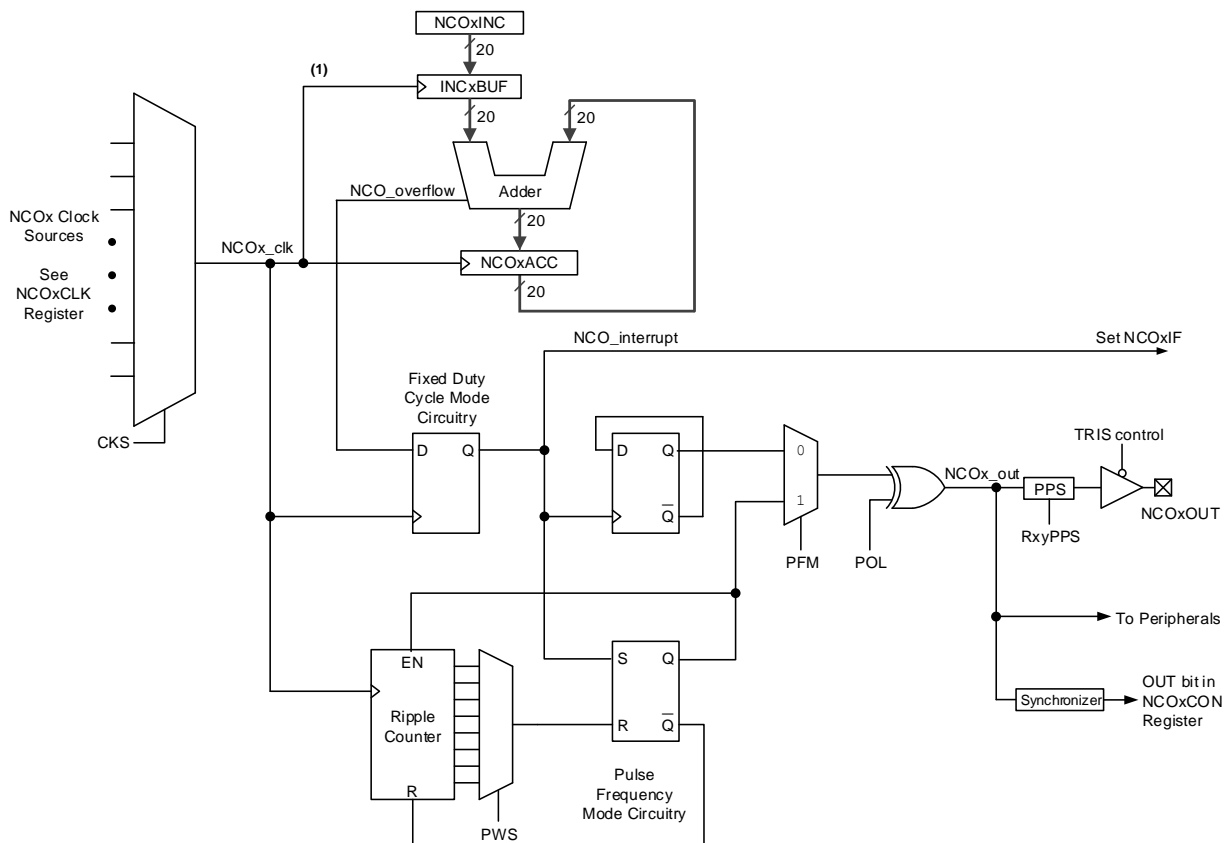

Note 1: The increment registers are double-buffered to allow for value changes to be made without first disabling the NCO module. The full increment value is loaded into the buffer registers on the second rising edge of the NCOx_clk signal that occurs immediately after a write to the NCOxINCL register. The buffers are not user-accessible and are shown here for reference.

25.1 NCO Operation

The NCO operates by repeatedly adding a fixed value to an accumulator. Additions occur at the input clock rate. The accumulator will overflow with a carry periodically, which is the raw NCO output (NCO_overflow). This effectively reduces the input clock by the ratio of the addition value to the maximum accumulator value. See the following equation.

Equation 25-1. NCO Overflow Frequency

$$F_{OVERFLOW} = \frac{NCO\ Clock\ Frequency \times Increment\ Value}{2^{20}}$$

It is apparent from the equation that there is a linear relationship between the increment value and the overflow frequency. This linear advantage over divide-by-n timers comes at the cost of output jitter. However, the jitter is always plus or minus one NCO clock period that occurs periodically, depending on the division remainder. For example, there is no jitter when there is no division remainder, whereas a division remainder of 0.5 will result in a jitter frequency one half of the overflow frequency.

25.1.1 NCO Clock Sources

The NCO can be clocked from a variety of sources including the system clock, internal timers, and other peripherals. The NCO clock source is selected by configuring the **CKS** bits.

25.1.2 Accumulator

The accumulator is a 20-bit register. Read and write access to the accumulator is available through three registers:

- NCOxACCL
- NCOxACCH
- NCOxACCU

25.1.3 Adder

The NCO adder is a full adder, which operates synchronously from the source clock. The addition of the previous result and the increment value replaces the accumulator value on the rising edge of each input clock.

25.1.4 Increment Registers

The increment value is stored in three registers making up a 20-bit word. In order of LSB to MSB, they are:

- NCOxINCL
- NCOxINCH
- NCOxINCU

The increment registers are readable and writable and are double-buffered to allow value changes to be made without first disabling the NCO module.

When the NCO module is enabled, the NCOxINCU and NCOxINCH registers will be written first, followed by the NCOxINCL register. Writing to the NCOxINCL register initiates the increment buffer registers to be loaded simultaneously on the second rising edge of the NCO_clk signal.

When the NCO module is disabled, the increment buffers are loaded immediately after a write to the increment registers.



Important: The increment buffer registers are not user-accessible.

25.2 Fixed Duty Cycle Mode

In Fixed Duty Cycle (FDC) mode, every time the accumulator overflows, the output is toggled. This provides a 50% duty cycle at half the F_{OVERFLOW} frequency, provided that the increment value remains constant. For more information, see the figure below.

The FDC mode is selected by clearing the **PFM** bit.

Figure 25-2. FDC Output Mode Timing Diagram

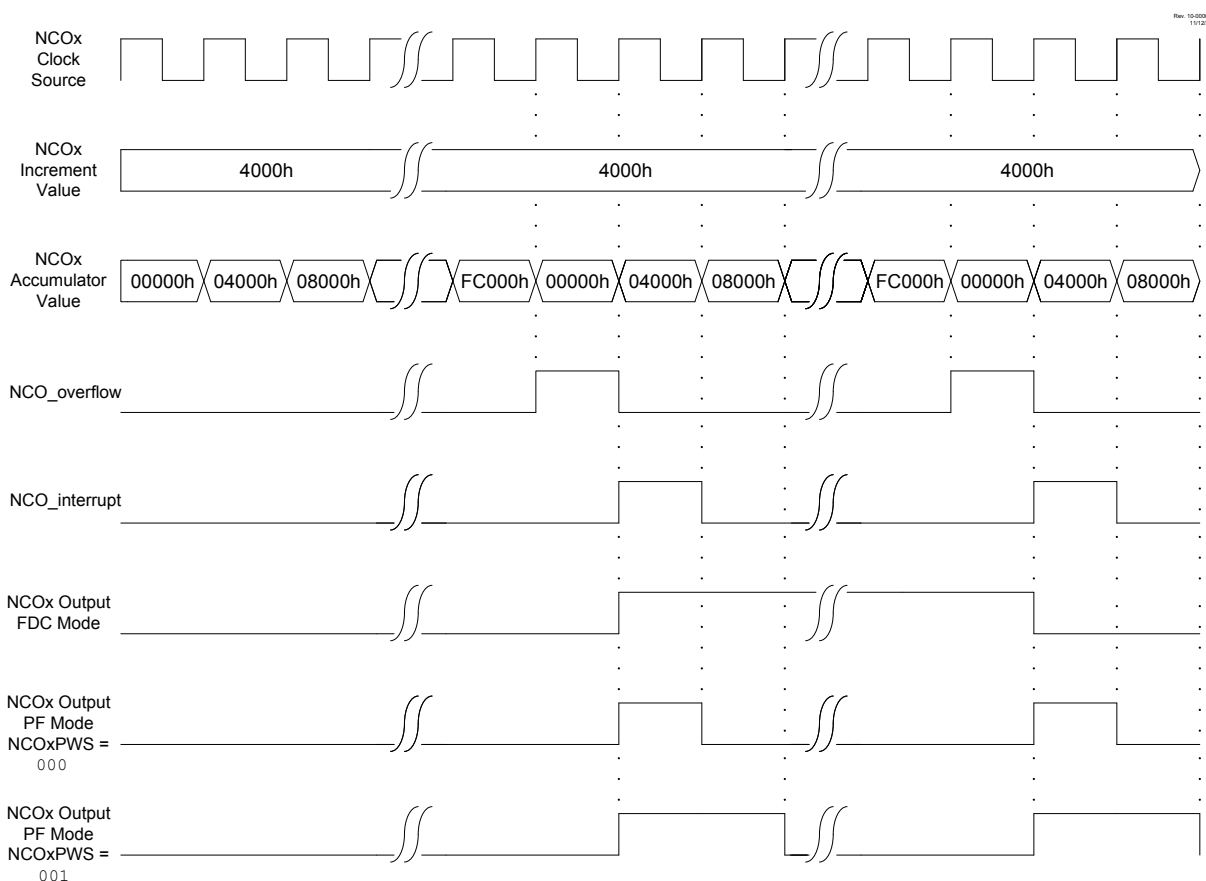

25.3 Pulse Frequency Mode

In Pulse Frequency (PF) mode, the output becomes active on the rising clock edge immediately following the overflow event and goes inactive 1 to 128 clock periods later, determined by the **PWS** bits. This provides a pulsed output at the F_{OVERFLOW} frequency. For more information, refer to the figure above.



Important: When the selected pulse width is greater than the accumulator overflow time frame, then the NCO output does not toggle.

The level of the Active and Inactive states is determined by the **POL** bit.

PF mode is selected by setting the [PFM](#) bit.

25.4 Output Polarity Control

The last stage in the NCO module is the output polarity. The [POL](#) bit selects the output polarity. The active level of the Pulse Frequency mode is high true when the POL bit is cleared.

Changing the polarity while the interrupts are enabled will cause an interrupt for the resulting output transition.

The NCO output signal (NCOx_out) is available by internal routing to several other peripherals.

25.5 Interrupts

When the accumulator overflows, the NCO Interrupt Flag bit, NCOxIF, in the associated PIR register is set. To enable interrupt service on this event, the following bits must be set:

- [EN](#) bit
- NCOxIE bit in the associated PIE register
- Peripheral and Global Interrupt Enable bits

The interrupt must be cleared by software by clearing the NCOxIF bit in the Interrupt Service Routine.

25.6 Effects of a Reset

All of the NCO registers are cleared to zero as the result of any Reset.

25.7 Operation in Sleep

The NCO module operates independently from the system clock and will continue to run during Sleep, provided that the clock source selected remains active.

The HFINTOSC remains active during Sleep when the NCO module is enabled and the HFINTOSC is selected as the clock source, regardless of the system clock source selected.

In other words, if the HFINTOSC is simultaneously selected as the system clock and the NCO clock source, when the NCO is enabled, the CPU will go Idle during Sleep, but the NCO will continue to operate and the HFINTOSC will remain active.

With a clock running, it will have a direct effect on the Sleep mode current.

25.8 Register Definitions: NCO

Long bit name prefixes for the NCO peripherals are shown in the table below. Refer to the “**Long Bit Names**” section in the “**Register and Bit Naming Conventions**” chapter for more information.

Table 25-1. NCO Long Bit Name Prefixes

Peripheral	Bit Name Prefix
NCO1	NCO1

25.8.1 NCOxCON

Name: NCOxCON

Offset: 0x0592

NCO Control Register

Bit	7	6	5	4	3	2	1	0
	EN		OUT	POL				PFM
Access	R/W		R	R/W				R/W
Reset	0		0	0				0

Bit 7 – EN NCO Enable

Value	Description
1	NCO module is enabled
0	NCO module is disabled

Bit 5 – OUT NCO Output

Displays the current logic level of the NCO module output.

Bit 4 – POL NCO Polarity

Value	Description
1	NCO output signal is inverted
0	NCO output signal is not inverted

Bit 0 – PFM NCO Pulse Frequency Mode

Value	Description
1	NCO operates in Pulse Frequency mode. Output frequency is F_{OVERFLOW} .
0	NCO operates in Fixed Duty Cycle mode. Output frequency is F_{OVERFLOW} divided by 2.

25.8.2 NCOxCLK

Name: NCOxCLK

Offset: 0x0593

NCO Input Clock Control Register

Bit	7	6	5	4	3	2	1	0
	PWS[2:0]				CKS[3:0]			
Access	R/W	R/W	R/W		R/W	R/W	R/W	R/W
Reset	0	0	0		0	0	0	0

Bits 7:5 – PWS[2:0] NCO Output Pulse-Width Select⁽¹⁾

Value	Description
111	NCO output is active for 128 input clock periods
110	NCO output is active for 64 input clock periods
101	NCO output is active for 32 input clock periods
100	NCO output is active for 16 input clock periods
011	NCO output is active for 8 input clock periods
010	NCO output is active for 4 input clock periods
001	NCO output is active for 2 input clock periods
000	NCO output is active for 1 input clock periods

Bits 3:0 – CKS[3:0] NCO Clock Source Select

CKS	Clock Source	Active in Sleep
Value	NCO1	
1111	Reserved	-
1110	CLC4_OUT	No
1101	CLC3_OUT	No
1100	CLC2_OUT	No
1011	CLC1_OUT	No
1010	Reserved	-
1001	TMR4_Postscaled_OUT	No
1000	TMR2_Postscaled_OUT	No
0111	CLKR_OUT	No
0110	EXTOSC	Yes
0101	SOSC	Yes
0100	MFINTOSC (32 kHz)	Yes
0011	MFINTOSC (500 kHz)	Yes
0010	LFINTOSC	Yes
0001	HFINTOSC	Yes
0000	F _{Osc}	No

Note:

1. PWS applies only when operating in Pulse Frequency mode.

25.8.3 NCOxACC

Name: NCOxACC

Offset: 0x058C

NCO Accumulator Register

Bit	23	22	21	20	19	18	17	16
	ACC[19:16]							
Access					R/W	R/W	R/W	R/W
Reset					0	0	0	0
Bit	15	14	13	12	11	10	9	8
	ACC[15:8]							
Access	R/W	R/W	R/W	R/W	R/W	R/W	R/W	R/W
Reset	0	0	0	0	0	0	0	0
Bit	7	6	5	4	3	2	1	0
	ACC[7:0]							
Access	R/W	R/W	R/W	R/W	R/W	R/W	R/W	R/W
Reset	0	0	0	0	0	0	0	0

Bits 19:0 – ACC[19:0] Accumulated sum of NCO additions

Notes:

- The individual bytes in this multibyte register can be accessed with the following register names:
 - NCOxACCU: Accesses the upper byte ACC[23:16]
 - NCOxACCH: Accesses the high byte ACC[15:8]
 - NCOxACCL: Accesses the low byte ACC[7:0].
- The accumulator spans registers NCOxACCU:NCOxACCH:NCOxACCL. The 24 bits are reserved, but not all are used. This register updates in real-time, asynchronously to the CPU; there is no provision to ensure atomic access to this 24-bit space using an 8-bit bus. Writing to this register while the module is operating will produce undefined results.

25.8.4 NCOxINC

Name: NCOxINC

Offset: 0x058F

NCO Increment Register

Bit	23	22	21	20	19	18	17	16
	INC[19:16]							
Access					R/W	R/W	R/W	R/W
Reset					0	0	0	0
Bit	15	14	13	12	11	10	9	8
	INC[15:8]							
Access	R/W	R/W	R/W	R/W	R/W	R/W	R/W	R/W
Reset	0	0	0	0	0	0	0	0
Bit	7	6	5	4	3	2	1	0
	INC[7:0]							
Access	R/W	R/W	R/W	R/W	R/W	R/W	R/W	R/W
Reset	0	0	0	0	0	0	0	1

Bits 19:0 – INC[19:0] Value by which the NCOxACC is increased by each NCO clock

Notes:

- The individual bytes in this multibyte register can be accessed with the following register names:
 - NCOxINC_U: Accesses the upper byte INC[19:16]
 - NCOxINC_H: Accesses the high byte INC[15:8]
 - NCOxINC_L: Accesses the low byte INC[7:0].
- The logical increment spans NCOxINC_U:NCOxINC_H:NCOxINC_L.
- NCOxINC is double-buffered as INC_{BUF}:
 - INC_{BUF} is updated on the next falling edge of NCOxCLK after writing to NCOxINC_L
 - NCOxINC_U and NCOxINC_H will be written prior to writing NCOxINC_L.

25.9 Register Summary - NCO

Offset	Name	Bit Pos.	7	6	5	4	3	2	1	0	
0x00 ... 0x058B	Reserved										
0x058C	NCO1ACC	7:0	ACC[7:0]								
		15:8	ACC[15:8]								
		23:16								ACC[19:16]	
0x058F	NCO1INC	7:0	INC[7:0]								
		15:8	INC[15:8]								
		23:16								INC[19:16]	
0x0592	NCO1CON	7:0	EN		OUT	POL				PFM	
0x0593	NCO1CLK	7:0	PWS[2:0]					CKS[3:0]			

26. CWG - Complementary Waveform Generator Module

The Complementary Waveform Generator (CWG) produces half-bridge, full-bridge, and steering of PWM waveforms. It is backward compatible with previous CCP functions.

The CWG has the following features:

- Six Operating modes:
 - Synchronous Steering mode
 - Asynchronous Steering mode
 - Full Bridge mode, Forward
 - Full Bridge mode, Reverse
 - Half Bridge mode
 - Push-Pull mode
- Output Polarity Control
- Output Steering
- Independent 6-bit Rising and Falling Event Dead-Band Timers:
 - Clocked dead band
 - Independent rising and falling dead-band enables
- Auto-Shutdown Control with:
 - Selectable shutdown sources
 - Auto-restart option
 - Auto-shutdown pin override control

26.1 Fundamental Operation

The CWG generates two output waveforms from the selected input source.

The off-to-on transition of each output can be delayed from the on-to-off transition of the other output, thereby creating a time delay immediately where neither output is driven. This is referred to as dead time and is covered in the [Dead-Band Control](#) section.

It may be necessary to guard against the possibility of circuit faults or a feedback event arriving too late or not at all. In this case, the active drive must be terminated before the Fault condition causes damage. This is referred to as auto-shutdown and is covered in the [Auto-Shutdown](#) section.

26.2 Operating Modes

The CWG module can operate in six different modes, as specified by the [MODE](#) bits:

- Half Bridge mode
- Push-Pull mode
- Asynchronous Steering mode
- Synchronous Steering mode
- Full Bridge mode, Forward
- Full Bridge mode, Reverse

All modes accept a single pulse input and provide up to four outputs as described in the following sections.

All modes include auto-shutdown control as described in the [Auto-Shutdown](#) section.



Important: Except as noted for [Full Bridge mode](#), mode changes must only be performed while $EN = 0$.

26.2.1 Half Bridge Mode

In Half Bridge mode, two output signals are generated as true and inverted versions of the input as illustrated in [Figure 26-1](#). A nonoverlap (dead band) time is inserted between the two outputs to prevent shoot-through current in various power supply applications. Dead-band control is described in the [Dead-Band Control](#) section. The output steering feature cannot be used in this mode. A basic block diagram of this mode is shown in [Figure 26-2](#).

The unused outputs CWGxC and CWGxD drive similar signals as CWGxA and CWGxB, with polarity independently controlled by the [POLC](#) and [POLD](#) bits, respectively.

Figure 26-1. CWG Half Bridge Mode Operation

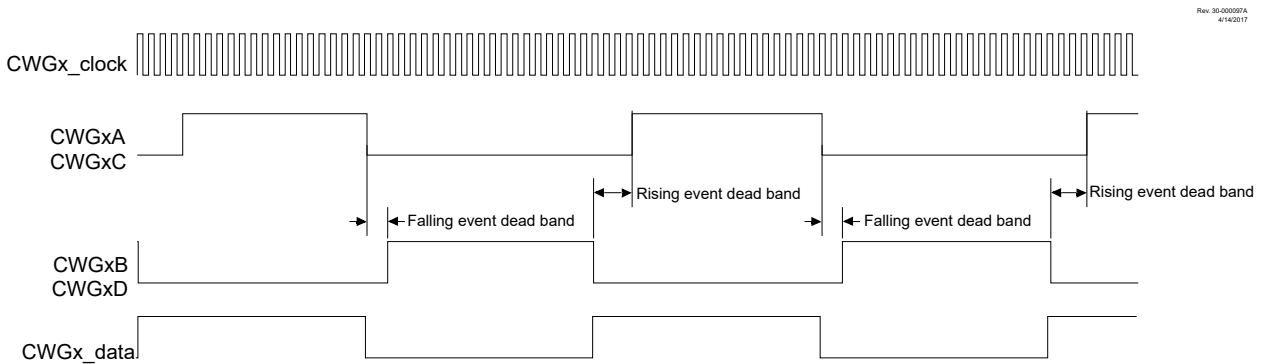
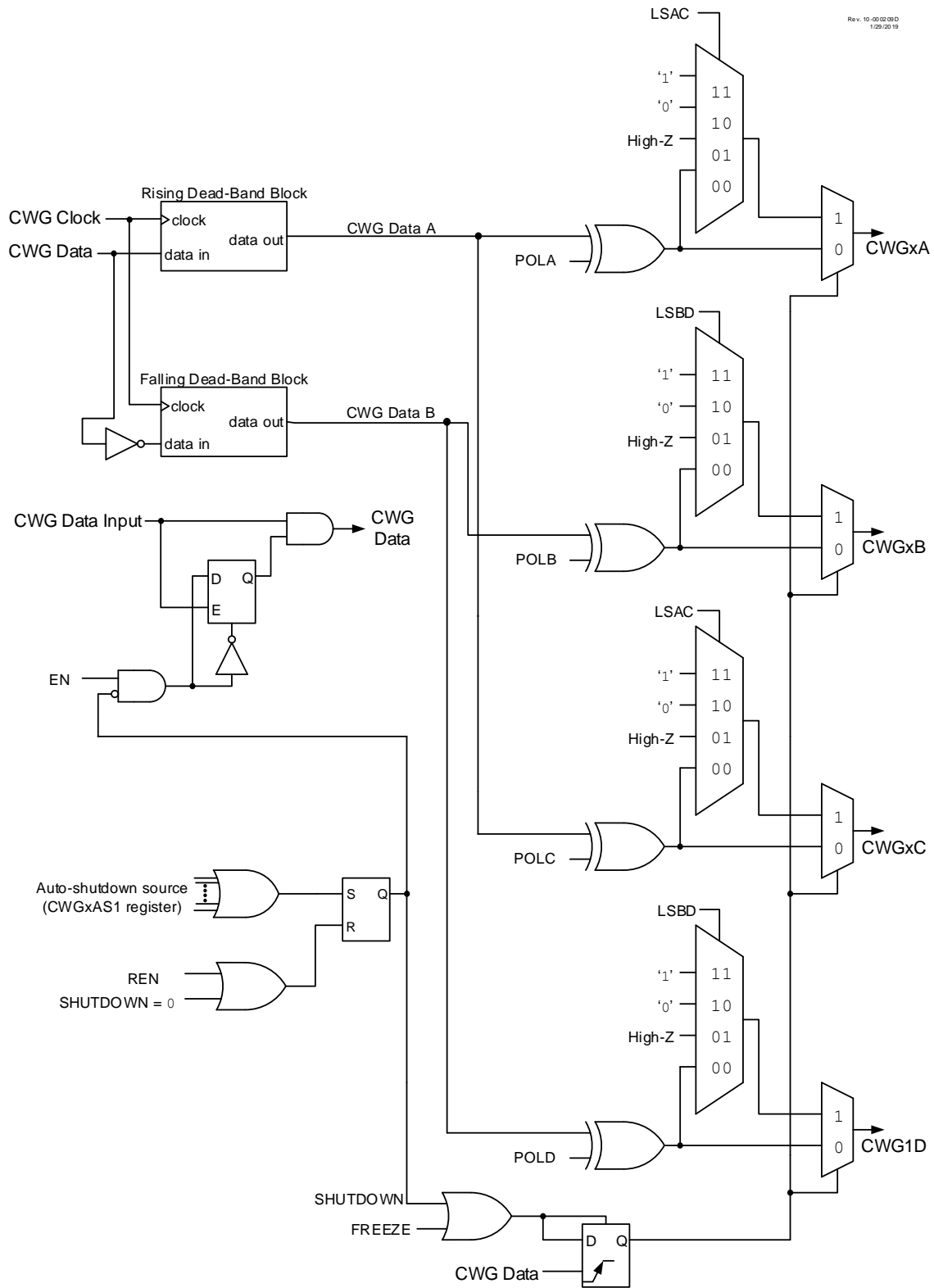

Figure 26-2. Simplified CWG Block Diagram (Half Bridge Mode, MODE = 'b100)



26.2.2 Push-Pull Mode

In Push-Pull mode, two output signals are generated, alternating copies of the input as illustrated in [Figure 26-3](#). This alternation creates the Push-Pull effect required for driving some transformer-based power supply designs. Steering modes are not used in Push-Pull mode. A basic block diagram for the Push-Pull mode is shown in [Figure 26-4](#).

The Push-Pull sequencer is reset whenever $EN = 0$ or if an auto-shutdown event occurs. The sequencer is clocked by the first input pulse, and the first output appears on CWGxA.

The unused outputs CWGxC and CWGxD drive copies of CWGxA and CWGxB, respectively, but with polarity controlled by the $POLC$ and $POLD$ bits, respectively.

Figure 26-3. CWG Push-Pull Mode Operation

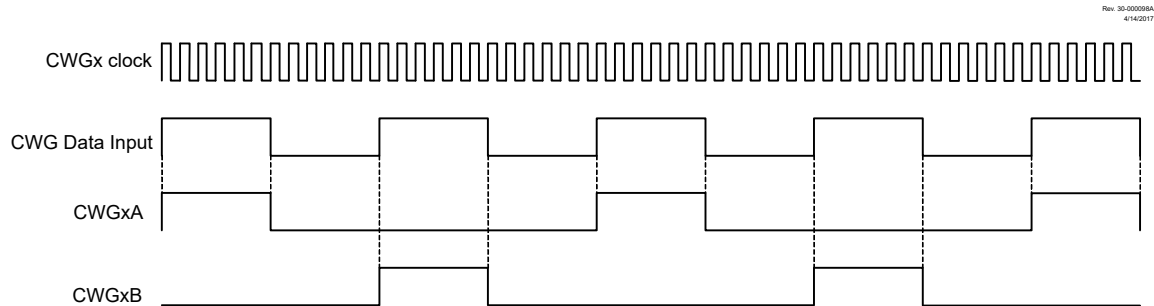
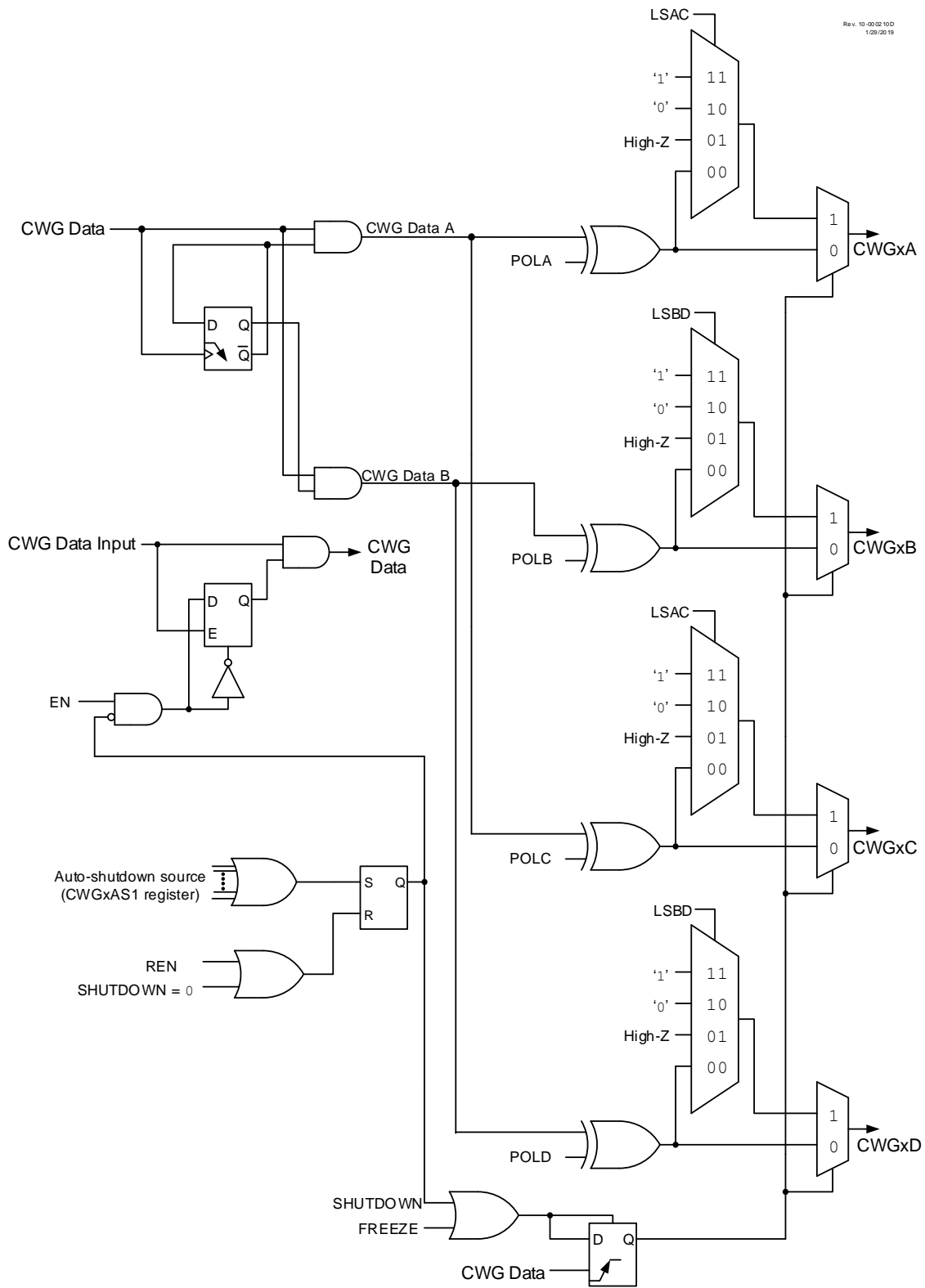

Figure 26-4. Simplified CWG Block Diagram (Push-Pull Mode, MODE = `b101)



26.2.3 Full Bridge Mode

In Forward and Reverse Full Bridge modes, three outputs drive static values while the fourth is modulated by the input data signal. The mode selection may be toggled between forward and reverse by toggling the MODE[0] bit of the CWGxCON0 register while keeping the MODE[2:1] bits static, without disabling the CWG module. When connected, as shown in Figure 26-5, the outputs are appropriate for a full-bridge motor driver. Each CWG output signal has independent polarity control, so the circuit can be adapted to high-active and low-active drivers. A simplified block diagram for the Full Bridge modes is shown in Figure 26-6.

Figure 26-5. Example of Full-Bridge Application

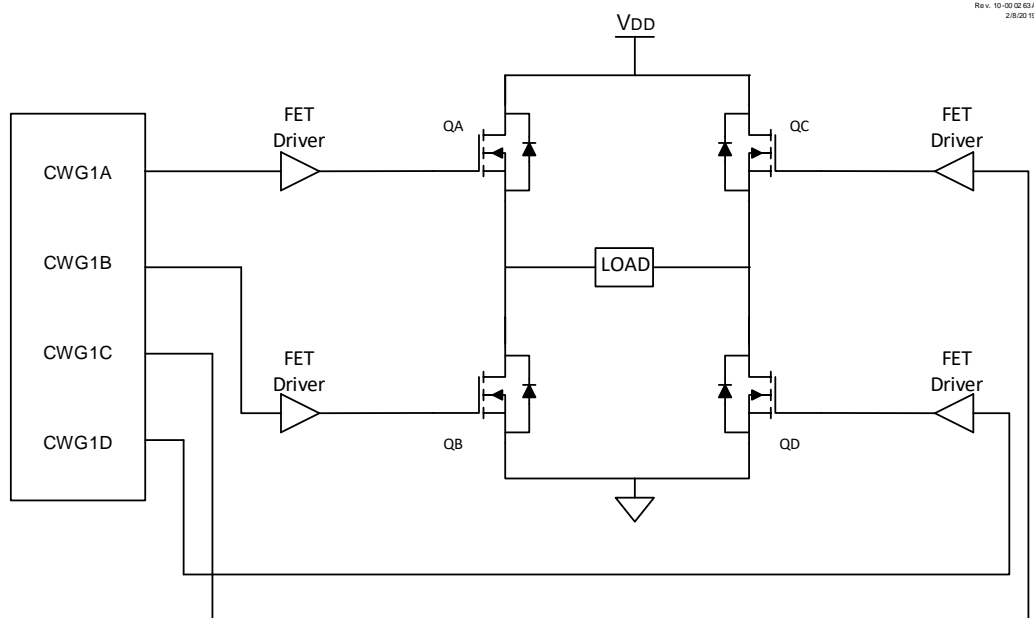
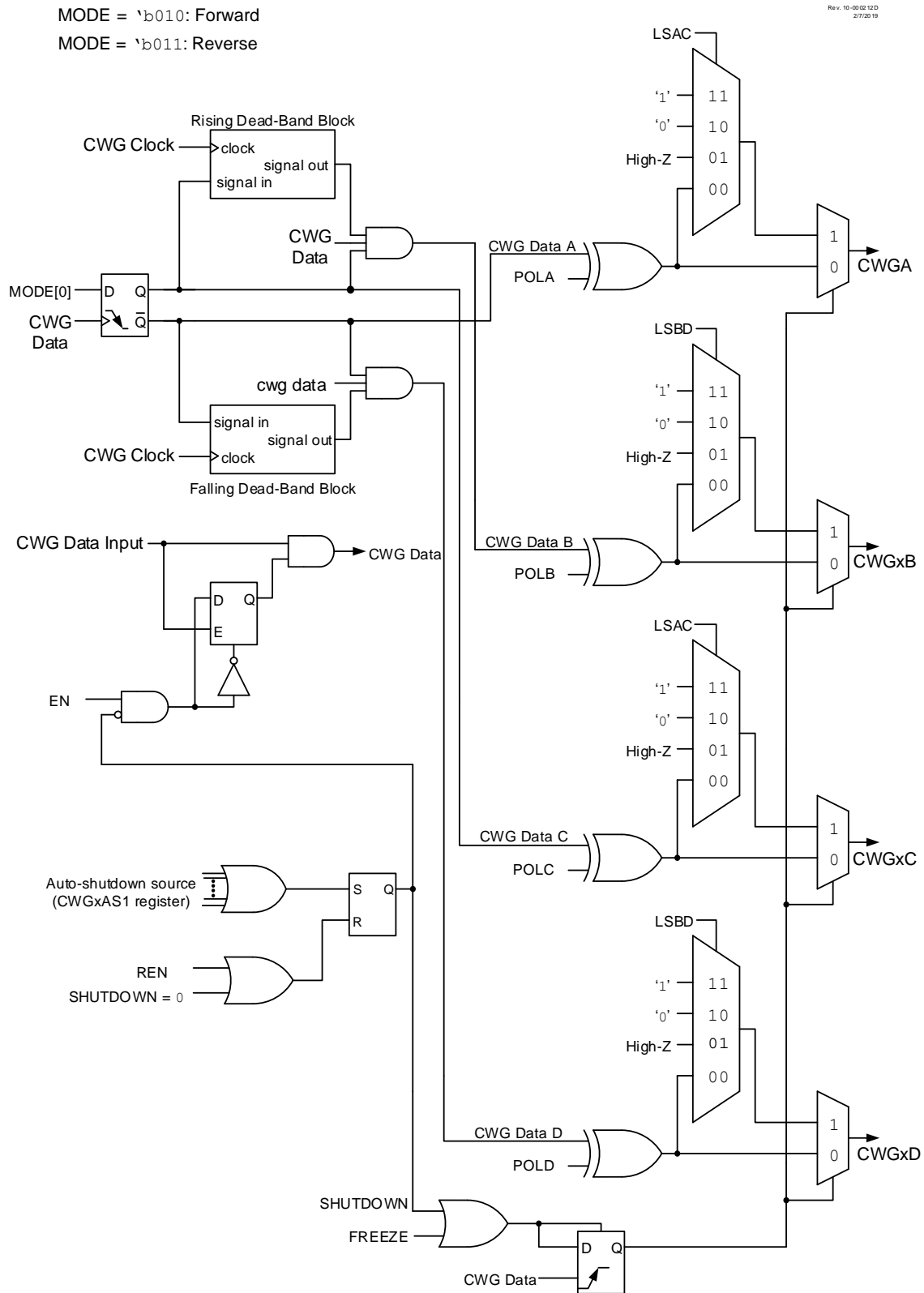

Figure 26-6. Simplified CWG Block Diagram (Forward and Reverse Full Bridge Modes)



In Forward Full Bridge mode ($MODE = \text{'b}010$), CWGxA is driven to its Active state, CWGxB and CWGxC are driven to their Inactive state, and CWGxD is modulated by the input signal, as shown in Figure 26-7.

In Reverse Full Bridge mode ($MODE = \text{'b}011$), CWGxC is driven to its Active state, CWGxA and CWGxD are driven to their Inactive states, and CWGxB is modulated by the input signal, as shown in Figure 26-7.

In Full Bridge mode, the dead-band period is used when there is a switch from forward to reverse or vice versa. This dead-band control is described in the [Dead-Band Control](#) section, with additional details in the [Rising Edge and Reverse Dead Band](#) and [Falling Edge and Forward Dead Band](#) sections. Steering modes are not used with either of the Full Bridge modes.

Figure 26-7. Example of Full-Bridge Output

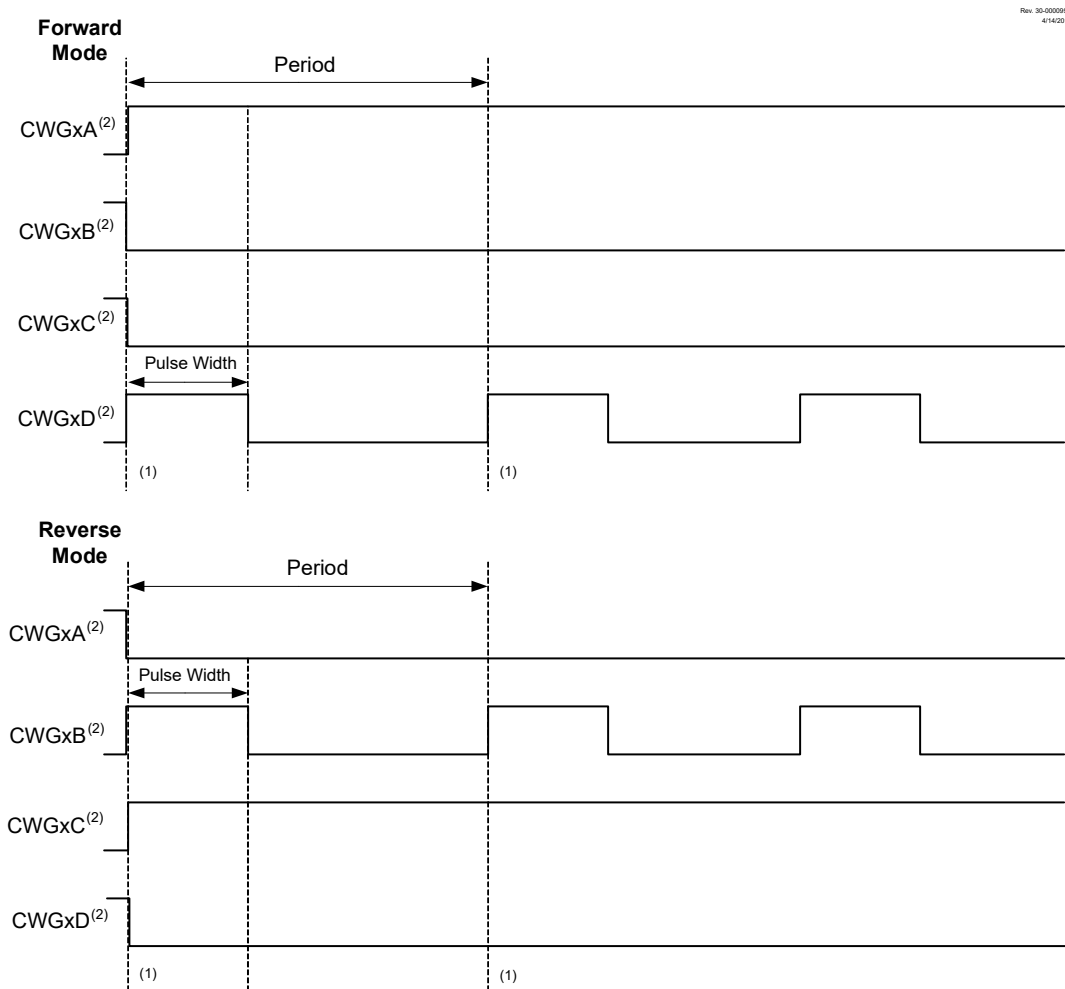

Notes:

1. A rising CWG data input creates a rising event on the modulated output.
2. Output signals shown as active-high; all POLY bits are clear.

26.2.3.1 Direction Change in Full Bridge Mode

In Full Bridge mode, changing the $MODE[0]$ bit controls the forward/reverse direction. Direction changes occur on the next rising edge of the modulated input. The sequence, described as follows, is illustrated in Figure 26-8.

1. The associated active output CWGxA and the inactive output CWGxC are switched to drive in the opposite direction.
2. The previously modulated output CWGxD is switched to the Inactive state, and the previously inactive output CWGxB begins to modulate.
3. CWG modulation resumes after the direction-switch dead band has elapsed.

Figure 26-8. Example of PWM Direction Change at Near 100% Duty Cycle

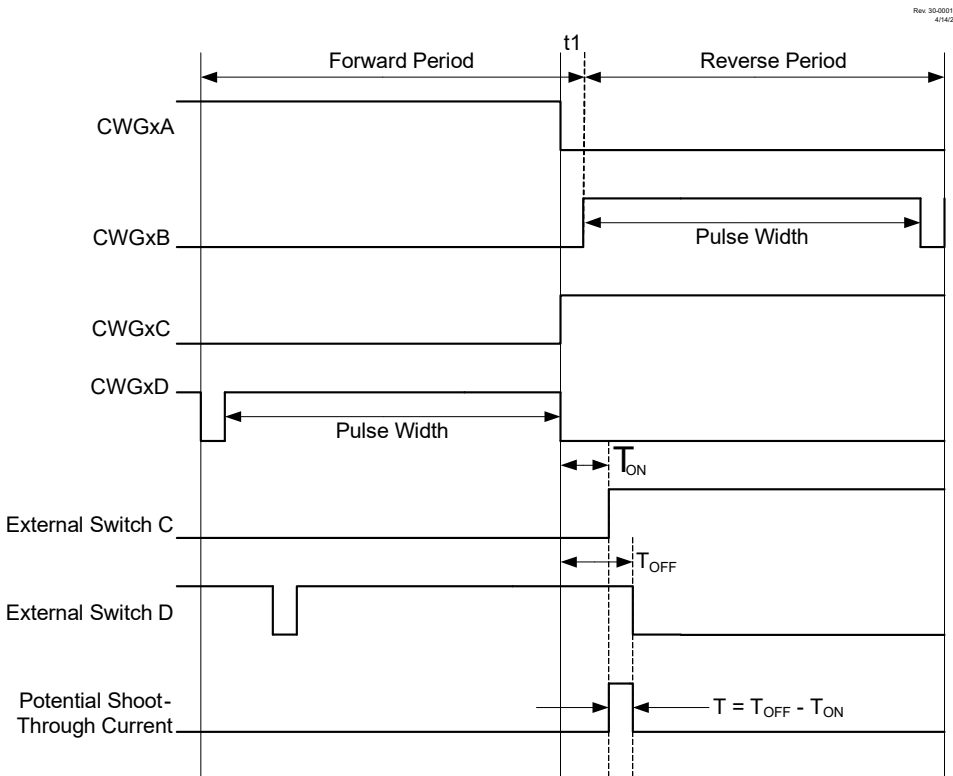

26.2.3.2 Dead-Band Delay in Full Bridge Mode

Dead-band delay is important when either of the following conditions is true:

- The direction of the CWG output changes when the duty cycle of the data input is at or near 100%
- The turn-off time of the power switch, including the power device and driver circuit, is greater than the turn-on time

The dead-band delay is inserted only when changing directions and only the modulated output is affected. The statically-configured outputs (CWGxA and CWGxC) are not afforded dead band and switch essentially simultaneously.

Figure 26-8 shows an example of the CWG outputs changing directions from forward to reverse, at near 100% duty cycle. In this example, at time t_1 , the output of CWGxA and CWGxD becomes inactive, while the output of CWGxC becomes active. Since the turn-off time of the power devices is longer than the turn-on time, a shoot-through current will flow through the power devices QC and QD for the duration of 'T'. The same phenomenon will occur to power devices QA and QB for the CWG direction change from reverse to forward.

When changing the CWG direction at high duty cycle is required for an application, two possible solutions for eliminating the shoot-through current are:

1. Reduce the CWG duty cycle for one period before changing directions.

2. Use switch drivers that can drive the switches off faster than they can drive them on.

26.2.4 Steering Modes

In both Synchronous and Asynchronous Steering modes, the CWG Data can be steered to any combination of four CWG outputs. A fixed value will be presented on all the outputs not used for the PWM output. Each output has independent polarity, steering, and shutdown options. Dead-band control is not used in either Steering mode.

For example, when $STRA = 0$, the corresponding pin is held at the level defined by $OVRA$. When $STRA = 1$, the pin is driven by the CWG Data signal. The $POLy$ bits control the signal polarity only when $STRy = 1$.

The CWG auto-shutdown operation also applies in Steering modes as described in the [Auto-Shutdown](#) section. An auto-shutdown event will only affect pins that have $STRy = 1$.

Figure 26-9. Simplified CWG Block Diagram (Output Steering Modes)

MODE = 'b000: Asynchronous

MODE = 'b001: Synchronous

Rev. 10 -0002 11D
2/7/20 19

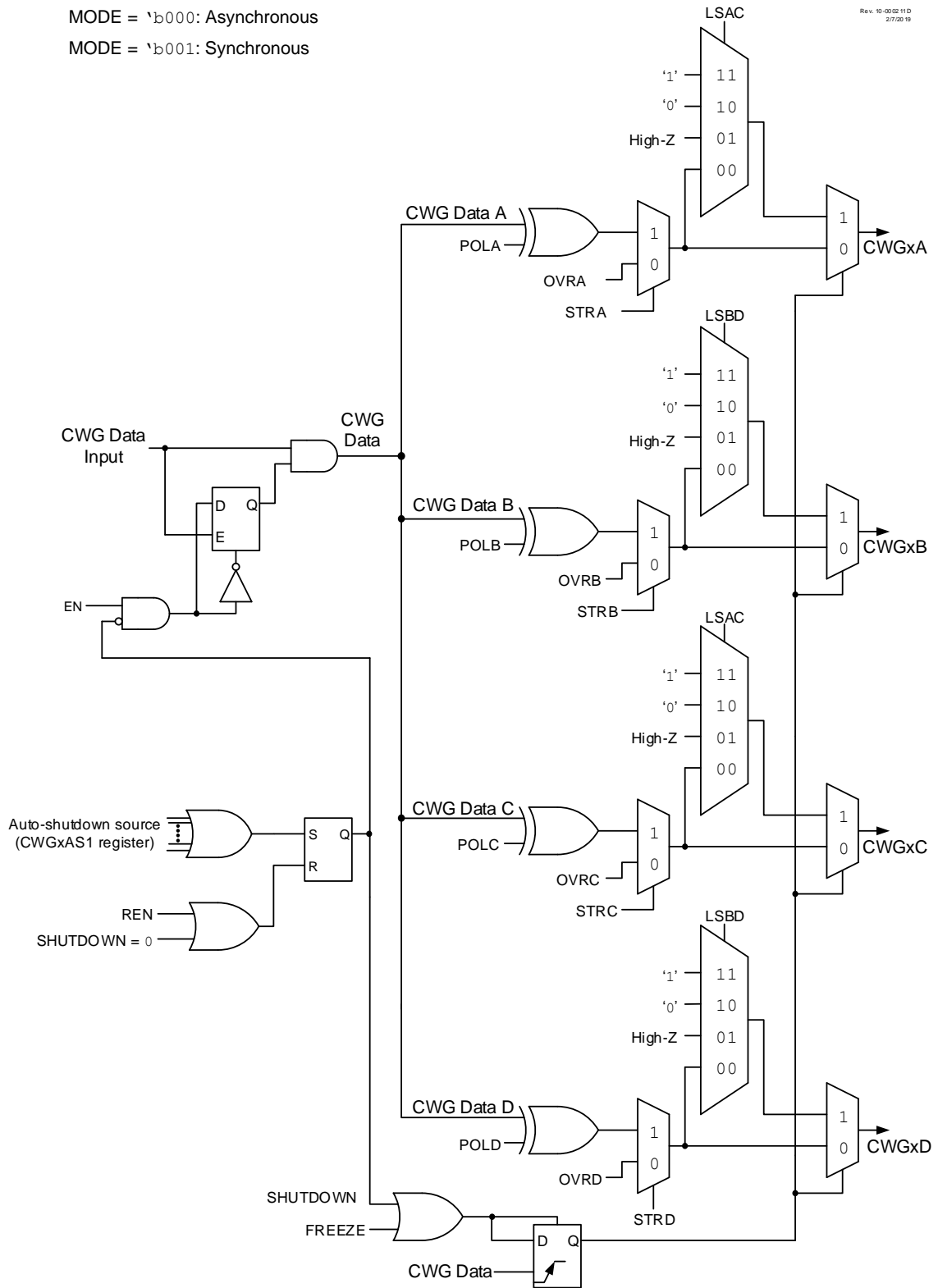

26.2.4.1 Synchronous Steering Mode

In Synchronous Steering mode ($MODE = \text{'b}001$), the changes to steering selection registers take effect on the next rising edge of CWG Data (see the figure below). In Synchronous Steering mode, the output will always produce a complete waveform.



Important: Only the STRx bits are synchronized; the OVRx bits are not synchronized.

Figure 26-10. Example of Synchronous Steering ($MODE = \text{'b}001$)

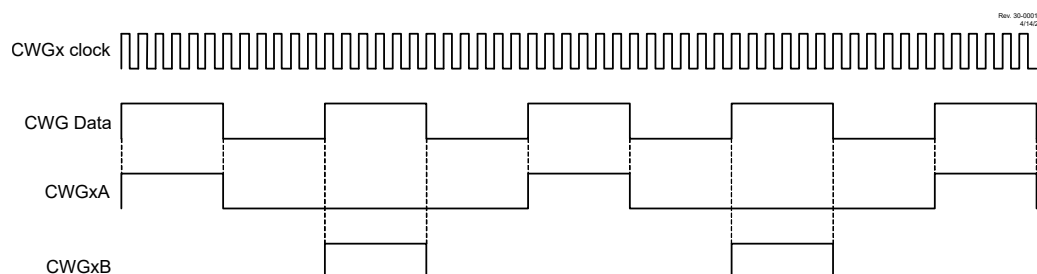

26.2.4.2 Asynchronous Steering Mode

In Asynchronous mode ($MODE = \text{'b}000$), steering takes effect at the end of the instruction cycle that writes to STRx. In Asynchronous Steering mode, the output signal may be an incomplete waveform (see the figure below). This operation may be useful when the user firmware needs to immediately remove a signal from the output pin.

Figure 26-11. Example of Asynchronous Steering ($MODE = \text{'b}000$)

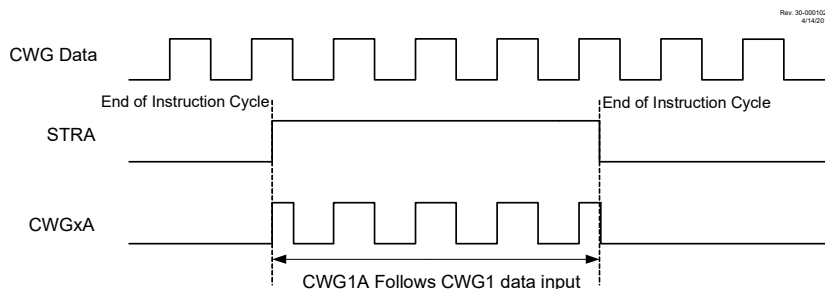

26.2.4.3 Start-Up Considerations

The application hardware must use the proper external pull-up and/or pull-down resistors on the CWG output pins. This is required because all I/O pins are forced to high-impedance at Reset.

The Polarity Control ($POLy$) bits allow the user to choose whether the output signals are active-high or active-low.

26.3 Clock Source

The clock source is used to drive the dead-band timing circuits. The CWG module allows the following clock sources to be selected:

- F_{OSC} (system clock)
- HFINTOSC

When the HFINTOSC is selected, the HFINTOSC will be kept running during Sleep. Therefore, the CWG modes requiring dead band can operate in Sleep, provided that the CWG data input is also active during Sleep. The clock sources are selected using the CS bit. The system clock F_{OSC} is disabled in Sleep and thus dead-band control cannot be used.

26.4 Selectable Input Sources

The CWG generates the output waveforms from the input sources which are selected with the [ISM](#) bits. Refer to the [CWGxISM](#) register for more details.

26.5 Output Control

26.5.1 CWG Output

Each CWG output can be routed to a Peripheral Pin Select (PPS) output via the RxyPPS register. Refer to the **“PPS - Peripheral Pin Select Module”** chapter for more details.

26.5.2 Polarity Control

The polarity of each CWG output can be selected independently. When the output polarity bit is set, the corresponding output is active-high. Clearing the output polarity bit configures the corresponding output as active-low. However, polarity does not affect the override levels. Output polarity is selected with the [POLy](#) bits. Auto-shutdown and steering options are unaffected by polarity.

26.6 Dead-Band Control

The dead-band control provides nonoverlapping complementary outputs to prevent shoot-through current when the outputs switch. Dead-band operation is employed for Half Bridge and Full Bridge modes. The CWG contains two 6-bit dead-band counters. One is used for the rising edge of the input source control in Half Bridge mode or for reverse direction change dead band in Full Bridge mode. The other is used for the falling edge of the input source control in Half Bridge mode or for forward direction change dead band in Full Bridge mode.

Dead band is timed by counting CWG clock periods from zero up to the value in the rising or falling dead-band counter registers.

26.6.1 Dead-Band Functionality in Half Bridge Mode

In Half Bridge mode, the dead-band counters dictate the delay between the falling edge of the normal output and the rising edge of the inverted output. This can be seen in [Figure 26-1](#).

26.6.2 Dead-Band Functionality in Full Bridge Mode

In Full Bridge mode, the dead-band counters are used when undergoing a direction change. The [MODE\[0\]](#) bit can be set or cleared while the CWG is running, allowing for changes from Forward to Reverse mode. The [CWGxA](#) and [CWGxC](#) signals will change immediately upon the first rising input edge following a direction change, but the modulated signals ([CWGxB](#) or [CWGxD](#), depending on the direction of the change) will experience a delay dictated by the dead-band counters.

26.7 Rising Edge and Reverse Dead Band

In Half Bridge mode, the rising edge dead band delays the turn-on of the [CWGxA](#) output after the rising edge of the CWG data input. In Full Bridge mode, the reverse dead-band delay is only inserted when changing directions from Forward mode to Reverse mode, and only the modulated output, [CWGxB](#), is affected.

The [CWGxDBR](#) register determines the duration of the dead-band interval on the rising edge of the input source signal. This duration is from 0 to 64 periods of the CWG clock. The following figure illustrates different dead-band delays for rising and falling CWG Data events.

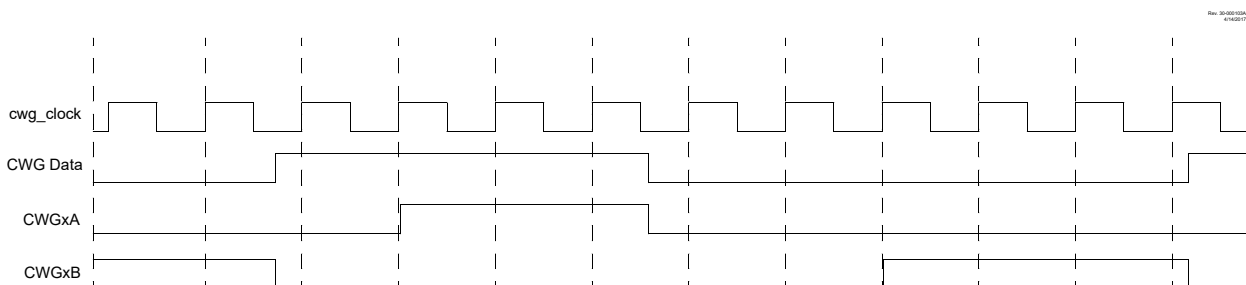
Figure 26-12. Dead-Band Operation, CWGxDBR = 0x01, CWGxDBF = 0x02

Dead band is always initiated on the edge of the input source signal. A count of zero indicates that no dead band is present.

If the input source signal reverses polarity before the dead-band count is completed, then no signal will be seen on the respective output.

The CWGxDBR register value is double-buffered. When $EN = 0$, the buffer is loaded when CWGxDBR is written. When $EN = 1$, the buffer will be loaded at the rising edge following the first falling edge of the CWG Data, after the LD bit is set.

26.8 Falling Edge and Forward Dead Band

In Half Bridge mode, the falling edge dead band delays the turn-on of the CWGxB output at the falling edge of the CWG data input. In Full Bridge mode, the forward dead-band delay is only inserted when changing directions from Reverse mode to Forward mode, and only the modulated output, CWGxD, is affected.

The CWGxDBF register determines the duration of the dead-band interval on the falling edge of the input source signal. This duration is from 0 to 64 periods of the CWG clock.

Dead-band delay is always initiated on the edge of the input source signal. A count of zero indicates that no dead band is present.

If the input source signal reverses polarity before the dead-band count is completed, then no signal will be seen on the respective output.

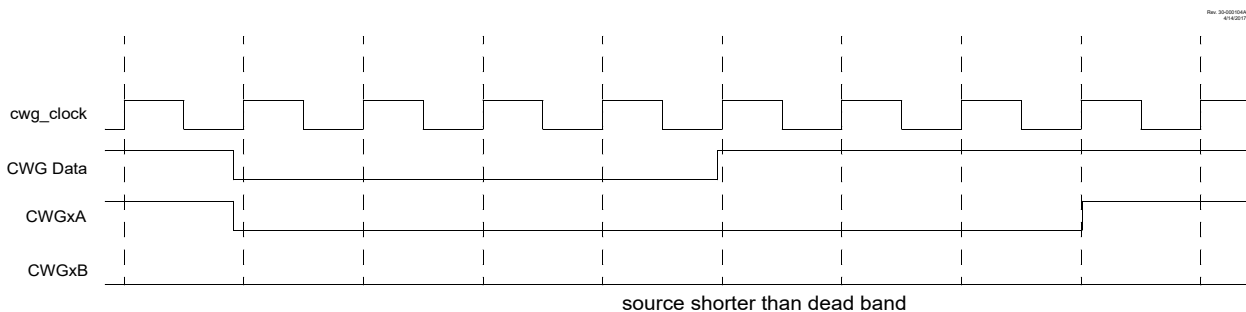
Figure 26-13. Dead-Band Operation, CWGxDBR = 0x03, CWGxDBF = 0x06, Source Shorter Than Dead Band

The CWGxDBF register value is double-buffered. When $EN = 0$, the buffer is loaded when CWGxDBF is written. When $EN = 1$, the buffer will be loaded at the rising edge following the first falling edge of the data input after the LD bit is set.

26.9 Dead-Band Jitter

When the rising and falling edges of the input source are asynchronous to the CWG clock, it creates jitter in the dead-band time delay. The maximum jitter is equal to one CWG clock period. Refer to the equations below for more details.

Equation 26-1. Dead-Band Delay Time Calculation

$$T_{DEAD - BAND_MIN} = \frac{1}{F_{CWG_CLOCK}} \cdot DBx$$

$$T_{DEAD - BAND_MAX} = \frac{1}{F_{CWG_CLOCK}} \cdot (DBx + 1)$$

$$T_{JITTER} = T_{DEAD - BAND_MAX} - T_{DEAD - BAND_MIN}$$

$$T_{JITTER} = \frac{1}{F_{CWG_CLOCK}}$$

$$T_{DEAD - BAND_MAX} = T_{DEAD - BAND_MIN} + T_{JITTER}$$

Dead-Band Delay Example Calculation

$$DBx = 0x0A = 10$$

$$F_{CWG_CLOCK} = 8 \text{ MHz}$$

$$T_{JITTER} = \frac{1}{8 \text{ MHz}} = 125 \text{ ns}$$

$$T_{DEAD - BAND_MIN} = 125 \text{ ns} \cdot 10 = 1.25 \text{ } \mu\text{s}$$

$$T_{DEAD - BAND_MAX} = 1.25 \text{ } \mu\text{s} + 0.125 \text{ } \mu\text{s} = 1.37 \text{ } \mu\text{s}$$

26.10 Auto-Shutdown

Auto-shutdown is a method to immediately override the CWG output levels with specific overrides that allow for safe shutdown of the circuit. The Shutdown state can be either cleared automatically or held until cleared by software. The auto-shutdown circuit is illustrated in the following figure.

Figure 26-14. CWG Shutdown Block Diagram

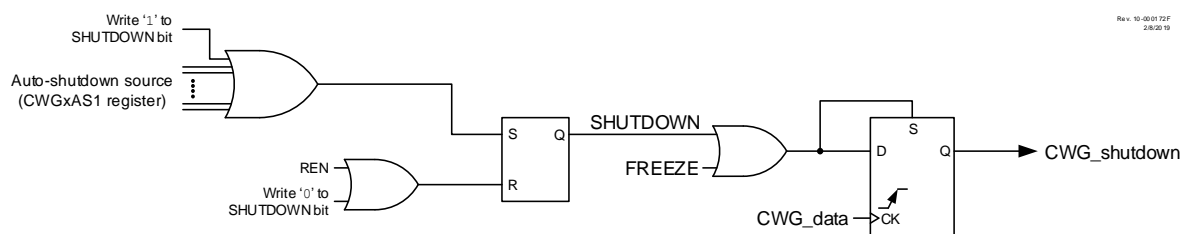

26.10.1 Shutdown

The Shutdown state can be entered by either of the following two methods:

- Software Generated
- External Input

26.10.2 Software Generated Shutdown

Setting the **SHUTDOWN** bit will force the CWG into the Shutdown state.

When the auto-restart is disabled, the Shutdown state will persist as long as the SHUTDOWN bit is set.

When auto-restart is enabled, the SHUTDOWN bit will clear automatically and resume operation on the next rising edge event. The SHUTDOWN bit indicates when a Shutdown condition exists. The bit may be set or cleared in software or by hardware.

26.10.3 External Input Source

External shutdown inputs provide the fastest way to safely suspend CWG operation in the event of a Fault condition. When any of the selected shutdown inputs goes active, the CWG outputs will immediately go to the selected override levels without software delay. The override levels are selected by the [LSBD](#) and [LSAC](#) bits. Several input sources can be selected to cause a Shutdown condition. All input sources are active-low. The shutdown input sources are individually enabled by the [ASyE](#) bits.



Important: Shutdown inputs are level sensitive, not edge sensitive. The Shutdown state cannot be cleared, except by disabling auto-shutdown, as long as the shutdown input level persists.

26.10.4 Pin Override Levels

The levels driven to the CWG outputs during an auto-shutdown event are controlled by the [LSBD](#) and [LSAC](#) bits. The LSBD bits control CWGxB/D output levels, while the LSAC bits control the CWGxA/C output levels.

26.10.5 Auto-Shutdown Interrupts

When an auto-shutdown event occurs, either by software or hardware setting SHUTDOWN, the CWGxIF flag bit of the PIRx register is set.

26.11 Auto-Shutdown Restart

After an auto-shutdown event has occurred, there are two ways to resume operation:

- Software controlled
- Auto-restart

In either case, the shutdown source must be cleared before the restart can take place. That is, either the Shutdown condition must be removed, or the corresponding [ASyE](#) bit must be cleared.

26.11.1 Software-Controlled Restart

When the [REN](#) bit is clear ($REN = 0$), the CWG module must be restarted after an auto-shutdown event through software.

Once all auto-shutdown sources are removed, the software must clear the SHUTDOWN bit. Once SHUTDOWN is cleared, the CWG module will resume operation upon the first rising edge of the CWG data input.

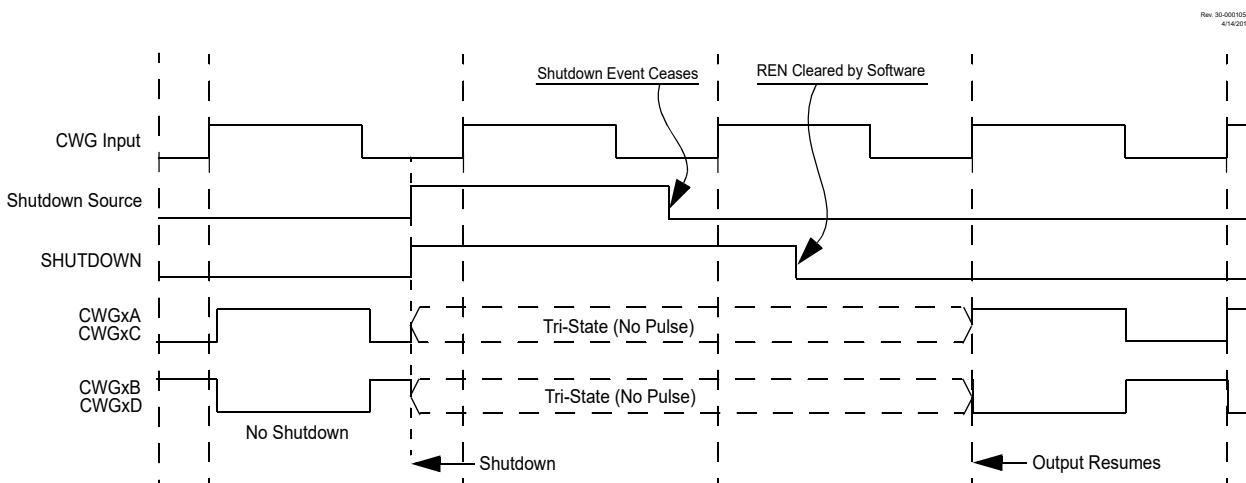

Important: The SHUTDOWN bit cannot be cleared in software if the Auto-Shutdown condition is still present.

Figure 26-15. Shutdown Functionality, Auto-Restart Disabled (REN = 0, LSAC = 'b01, LSB0 = 'b01)

26.11.2 Auto-Restart

When the **REN** bit is set (REN = 1), the CWG module will restart from the Shutdown state automatically.

Once all Auto-Shutdown conditions are removed, the hardware will automatically clear the SHUTDOWN bit. Once SHUTDOWN is cleared, the CWG module will resume operation upon the first rising edge of the CWG data input.

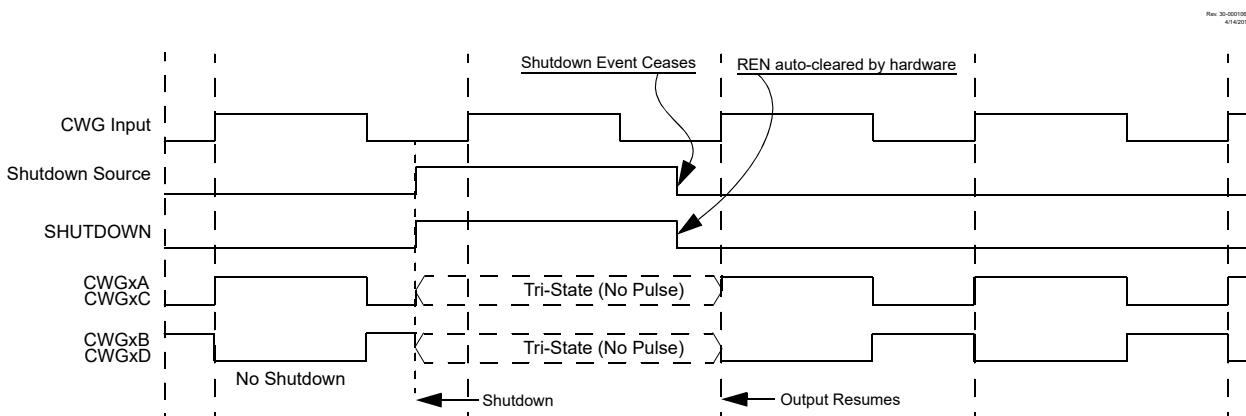

Important: The SHUTDOWN bit cannot be cleared in software if the Auto-Shutdown condition is still present.

Figure 26-16. Shutdown Functionality, Auto-Restart Enabled (REN = 1, LSAC = 'b01, LSB0 = 'b01)

26.12 Operation During Sleep

The CWG module operates independently from the system clock and will continue to run during Sleep, provided that the clock and input sources selected remain active.

The HFINTOSC remains active during Sleep when all the following conditions are met:

- CWG module is enabled
- Input source is active
- HFINTOSC is selected as the clock source, regardless of the system clock source selected.

In other words, if the HFINTOSC is simultaneously selected as the system clock and the CWG clock source when the CWG is enabled and the input source is active, then the CPU will go Idle during Sleep, but the HFINTOSC will remain active, and the CWG will continue to operate. This will have a direct effect on the Sleep mode current.

26.13 Configuring the CWG

1. Ensure that the TRIS control bits corresponding to CWG outputs are set so that all are configured as inputs, ensuring that the outputs are inactive during setup. External hardware must ensure that pin levels are held to safe levels.
2. Clear the **EN** bit, if not already cleared.
3. Configure the **MODE** bits to set the output operating mode.
4. Configure the **POLy** bits to set the output polarities.
5. Configure the **ISM** bits to select the data input source.
6. If a Steering mode is selected, configure the **STRy** bits to select the desired output on the CWG outputs.
7. Configure the **LSBD** and **LSAC** bits to select the Auto-Shutdown Output Override states (this is necessary even if not using auto-shutdown, because start-up will be from a Shutdown state).
8. If auto-restart is desired, set the **REN** bit.
9. If auto-shutdown is desired, configure the **ASyE** bits to select the shutdown source.
10. Set the desired rising and falling dead-band times with the CWGxDBR and CWGxDBF registers.
11. Select the clock source with the **CS** bit.
12. Set the **EN** bit to enable the module.
13. Clear the TRIS bits that correspond to the CWG outputs to set them as outputs.

If auto-restart is to be used, set the **REN** bit and the **SHUTDOWN** bit will be cleared automatically. Otherwise, clear the **SHUTDOWN** bit in software to start the CWG.

26.14 Register Definitions: CWG Control

Long bit name prefixes for the CWG peripherals are shown in the table below. Refer to the “**Long Bit Names**” section in the “**Register and Bit Naming Conventions**” chapter for more information.

Table 26-1. CWG Long Bit Name Prefixes

Peripheral	Bit Name Prefix
CWG1	CWG1

26.14.1 CWGxCON0**Name:** CWGxCON0**Offset:** 0x0610

CWG Control Register 0

Bit	7	6	5	4	3	2	1	0
	EN	LD				MODE[2:0]		
Access	R/W	R/W/HC				R/W	R/W	R/W
Reset	0	0				0	0	0

Bit 7 – EN CWG Enable

Value	Description
1	Module is enabled
0	Module is disabled

Bit 6 – LD CWG1 Load Buffers⁽¹⁾

Value	Description
1	Dead-band count buffers to be loaded on CWG data rising edge, following first falling edge after this bit is set
0	Buffers remain unchanged

Bits 2:0 – MODE[2:0] CWG Mode

Value	Description
111	Reserved
110	Reserved
101	CWG outputs operate in Push-Pull mode
100	CWG outputs operate in Half Bridge mode
011	CWG outputs operate in Reverse Full Bridge mode
010	CWG outputs operate in Forward Full Bridge mode
001	CWG outputs operate in Synchronous Steering mode
000	CWG outputs operate in Asynchronous Steering mode

Note:

1. This bit can only be set after EN = 1; it cannot be set in the same cycle when EN is set.

26.14.2 CWGxCON1**Name:** CWGxCON1**Offset:** 0x0611

CWG Control Register 1

Bit	7	6	5	4	3	2	1	0
			IN		POLD	POLC	POLB	POLA
Access			R		R/W	R/W	R/W	R/W
Reset			x		0	0	0	0

Bit 5 - IN CWG Input Value (read-only)

Value	Description
1	CWG data input is a logic '1'
0	CWG data input is a logic '0'

Bits 0, 1, 2, 3 - POLy CWG Output 'y' Polarity

Value	Description
1	Signal output is inverted polarity
0	Signal output is normal polarity

26.14.3 CWGxCLK

Name: CWGxCLK
Offset: 0x060C

CWG Clock Input Selection Register

Bit	7	6	5	4	3	2	1	0
								CS
Access								R/W
Reset								0

Bit 0 – CS CWG Clock Source Selection Select

Value	Description
1	HFINTOSC (remains operating during Sleep)
0	F _{osc}

26.14.4 CWGxISM

Name: CWGxISM

Offset: 0x060D

CWGx Input Selection Register

Bit	7	6	5	4	3	2	1	0
				ISM[4:0]				
Access				R/W	R/W	R/W	R/W	R/W
Reset				0	0	0	0	0

Bits 4:0 – ISM[4:0] CWG Data Input Source Select

ISM	Input Selection
	CWG1
11111-10010	Reserved
10001	CLC4_OUT
10000	CLC3_OUT
01111	CLC2_OUT
01110	CLC1_OUT
01101	C2_OUT
01100	C1_OUT
01011	NCO1_OUT
01010-00111	Reserved
00110	PWM2S1P2_OUT
00101	PWM2S1P1_OUT
00100	PWM1S1P2_OUT
00011	PWM1S1P1_OUT
00010	CCP2_OUT
00001	CCP1_OUT
00000	Pin selected by CWG1PPS

26.14.5 CWGxSTR

Name: CWGxSTR

Offset: 0x0614

CWG Steering Control Register⁽¹⁾

Bit	7	6	5	4	3	2	1	0
	OVRD	OVRC	OVRB	OVRA	STRD	STRC	STRB	STRA
Access	R/W	R/W	R/W	R/W	R/W	R/W	R/W	R/W
Reset	0	0	0	0	0	0	0	0

Bits 4, 5, 6, 7 – OVRy Steering Data OVR'y'

Value	Condition	Description
x	STRy = 1	CWGx'y' output has the CWG data input waveform with polarity control from POLy bit
1	STRy = 0 and POLy = x	CWGx'y' output is high
0	STRy = 0 and POLy = x	CWGx'y' output is low

Bits 0, 1, 2, 3 – STRy STR'y' Steering Enable⁽²⁾

Value	Description
1	CWGx'y' output has the CWG data input waveform with polarity control from the POLy bit
0	CWGx'y' output is assigned to value of the OVRy bit

Notes:

1. The bits in this register apply only when MODE = 'b00x (CWGxCON0, Steering modes).
2. This bit is double-buffered when MODE = 'b001.

26.14.6 CWGxAS0

Name: CWGxAS0

Offset: 0x0612

CWG Auto-Shutdown Control Register 0

Bit	7	6	5	4	3	2	1	0
	SHUTDOWN	REN	LSBD[1:0]		LSAC[1:0]			
Access	R/W/HS/HC	R/W	R/W	R/W	R/W	R/W		
Reset	0	0	0	1	0	1		

Bit 7 – SHUTDOWN Auto-Shutdown Event Status^(1,2)

Value	Description
1	An Auto-Shutdown state is in effect
0	No auto-shutdown event has occurred

Bit 6 – REN Auto-Restart Enable

Value	Description
1	Auto-restart is enabled
0	Auto-restart is disabled

Bits 5:4 – LSBD[1:0] CWGxB and CWGxD Auto-Shutdown State Control

Value	Description
11	A logic '1' is placed on CWGxB/D when an auto-shutdown event occurs
10	A logic '0' is placed on CWGxB/D when an auto-shutdown event occurs
01	Pin is tri-stated on CWGxB/D when an auto-shutdown event occurs
00	The Inactive state of the pin, including polarity, is placed on CWGxB/D after the required dead-band interval when an auto-shutdown event occurs

Bits 3:2 – LSAC[1:0] CWGxA and CWGxC Auto-Shutdown State Control

Value	Description
11	A logic '1' is placed on CWGxA/C when an auto-shutdown event occurs
10	A logic '0' is placed on CWGxA/C when an auto-shutdown event occurs
01	Pin is tri-stated on CWGxA/C when an auto-shutdown event occurs
00	The Inactive state of the pin, including polarity, is placed on CWGxA/C after the required dead-band interval when an auto-shutdown event occurs

Notes:

1. This bit may be written while **EN** = 0, to place the outputs into the shutdown configuration.
2. The outputs will remain in Auto-Shutdown state until the next rising edge of the CWG data input after this bit is cleared.

26.14.7 CWGxAS1

Name: CWGxAS1

Offset: 0x0613

CWG Auto-Shutdown Control Register 1

Bit	7	6	5	4	3	2	1	0
	AS7E	AS6E	AS5E	AS4E	AS3E	AS2E	AS1E	AS0E
Access	R/W	R/W	R/W	R/W	R/W	R/W	R/W	R/W
Reset	0	0	0	0	0	0	0	0

Bits 0, 1, 2, 3, 4, 5, 6, 7 - ASyE CWG Auto-Shutdown Source Enable^(1,2)

ASyE	Auto-Shutdown Source	
	CWG1	
AS7E		CLC4_OUT
AS6E		CLC2_OUT
AS5E		C2_OUT
AS4E		C1_OUT
AS3E		Reserved
AS2E		TMR4_Postscaled_OUT
AS1E		TMR2_Postscaled_OUT
AS0E		Pin selected by CWG1PPS

Notes:

1. This bit may be written while **EN** = 0, to place the outputs into the shutdown configuration.
2. The outputs will remain in Auto-Shutdown state until the next rising edge of the CWG data input after this bit is cleared.

26.14.8 CWGxDBR

Name: CWGxDBR
Offset: 0x060E

CWG Rising Dead-Band Count Register

Bit	7	6	5	4	3	2	1	0
			DBR[5:0]					
Access			R/W	R/W	R/W	R/W	R/W	R/W
Reset			x	x	x	x	x	x

Bits 5:0 – DBR[5:0] CWG Rising Edge-Triggered Dead-Band Count

Reset States: POR/BOR = xxxxxx

All Other Resets = uuuuuu

Value	Description
n	Dead band is active no less than n and no more than n+1 CWG clock periods after the rising edge
0	0 CWG clock periods. Dead-band generation is bypassed.

26.14.9 CWGxDBF

Name: CWGxDBF
Offset: 0x060F

CWG Falling Dead-Band Count Register

Bit	7	6	5	4	3	2	1	0
			DBF[5:0]					
Access			R/W	R/W	R/W	R/W	R/W	R/W
Reset			x	x	x	x	x	x

Bits 5:0 – DBF[5:0] CWG Falling Edge-Triggered Dead-Band Count

Reset States: POR/BOR = xxxxxx

All Other Resets = uuuuuu

Value	Description
n	Dead band is active no less than n and no more than n+1 CWG clock periods after the falling edge
0	0 CWG clock periods. Dead-band generation is bypassed.

26.15 Register Summary - CWG

Offset	Name	Bit Pos.	7	6	5	4	3	2	1	0
0x00 ...	Reserved									
0x060B										
0x060C	CWG1CLK	7:0								CS
0x060D	CWG1ISM	7:0				ISM[4:0]				
0x060E	CWG1DBR	7:0				DBR[5:0]				
0x060F	CWG1DBF	7:0				DBF[5:0]				
0x0610	CWG1CON0	7:0	EN	LD				MODE[2:0]		
0x0611	CWG1CON1	7:0			IN		POLD	POLC	POLB	POLA
0x0612	CWG1AS0	7:0	SHUTDOWN	REN	LSBD[1:0]		LSAC[1:0]			
0x0613	CWG1AS1	7:0	AS7E	AS6E	AS5E	AS4E	AS3E	AS2E	AS1E	AS0E
0x0614	CWG1STR	7:0	OVRD	OVRC	OVRB	OVRA	STRD	STRC	STRB	STRA

27. CCP - Capture/Compare/PWM Module

The Capture/Compare/PWM module is a peripheral that allows the user to time and control different events and to generate Pulse-Width Modulation (PWM) signals. In Capture mode, the peripheral allows the timing of the duration of an event. The Compare mode allows the user to trigger an external event when a predetermined amount of time has expired. The PWM mode can generate Pulse-Width Modulated signals of varying frequency and duty cycle.

Each individual CCP module can select the timer source that controls the module. The default timer selection is Timer1 when using Capture/Compare mode and Timer2 when using PWM mode in the CCPx module.

Note that the Capture/Compare mode operation is described with respect to Timer1 and the PWM mode operation is described with respect to Timer2 in the following sections.

The Capture and Compare functions are identical for all CCP modules.



Important: In devices with more than one CCP module, it is very important to pay close attention to the register names used. Throughout this section, the prefix “CCPx” is used as a generic replacement for specific numbering. A number placed where the “x” is in the prefix is used to distinguish between separate modules. For example, CCP1CON and CCP2CON control the same operational aspects of two completely different CCP modules.

27.1 CCP Module Configuration

Each Capture/Compare/PWM module is associated with a control register (**CCPxCON**), a capture input selection register (**CCPxCAP**) and a data register (**CCPRx**). The data register, in turn, is comprised of two 8-bit registers: CCPRxL (low byte) and CCPRxH (high byte).

27.1.1 CCP Modules and Timer Resources

The CCP modules utilize Timers 1 through 4 that vary with the selected mode. Various timers are available to the CCP modules in Capture, Compare or PWM modes, as shown in the table below.

Table 27-1. CCP Mode - Timer Resources

CCP Mode	Timer Resource
Capture	Timer1, Timer3
Compare	
PWM	Timer2, Timer4

The assignment of a particular timer to a module is selected as shown in the **“Capture, Compare, and PWM Timers Selection”** chapter. All of the modules may be active at once and may share the same timer resource if they are configured to operate in the same mode (Capture/Compare or PWM) at the same time.

27.1.2 Open-Drain Output Option

When operating in Output mode (the Compare or PWM modes), the drivers for the CCPx pins can be optionally configured as open-drain outputs. This feature allows the voltage level on the pin to be pulled to a higher level through an external pull-up resistor and allows the output to communicate with external circuits without the need for additional level shifters.

27.2 Capture Mode

Capture mode makes use of the 16-bit odd numbered timer resources (Timer1, Timer3, etc.). When an event occurs on the capture source, the 16-bit CCPRx register captures and stores the 16-bit value of the TMRx register. An event is defined as one of the following and is configured by the **MODE** bits:

- Every falling edge of CCPx input
- Every rising edge of CCPx input
- Every 4th rising edge of CCPx input
- Every 16th rising edge of CCPx input
- Every edge of CCPx input (rising or falling)

When a capture is made, the Interrupt Request Flag bit CCPxIF of the PIRx register is set. The interrupt flag must be cleared in software. If another capture occurs before the value in the CCPRx register is read, the old captured value is overwritten by the new captured value. The following figure shows a simplified diagram of the capture operation.



Important: If an event occurs during a 2-byte read, the high and low-byte data will be from different events. It is recommended while reading the CCPRx register pair to either disable the module or read the register pair twice for data integrity.

Figure 27-1. Capture Mode Operation Block Diagram

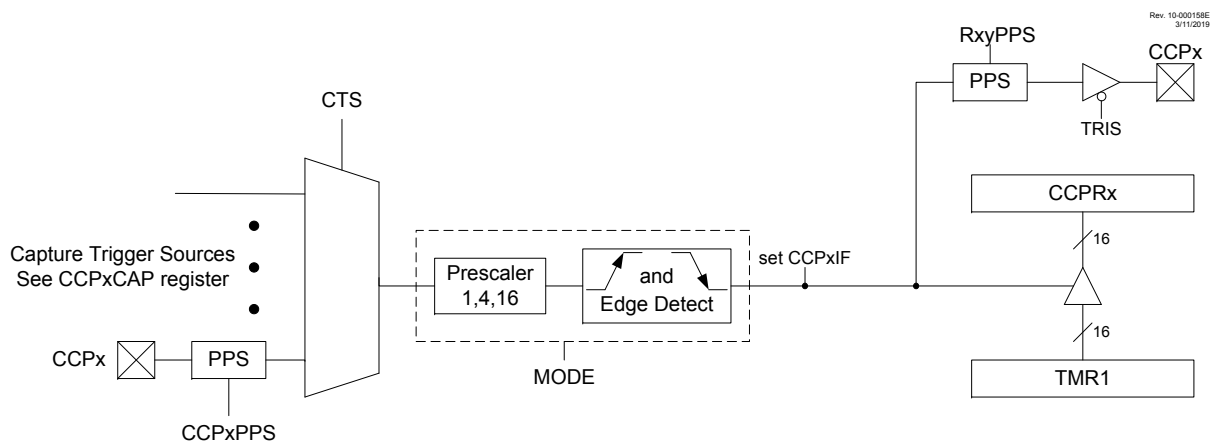

27.2.1 Capture Sources

The capture source is selected with the **CTS** bits.

In Capture mode, the CCPx pin must be configured as an input by setting the associated TRIS control bit.



Important: If the CCPx pin is configured as an output, a write to the port can cause a capture event.

27.2.2 Timer1 Mode for Capture

Timer1 must be running in Timer mode or Synchronized Counter mode for the CCP module to use the capture feature. In Asynchronous Counter mode, the capture operation may not work.

See the “**TMR1 - Timer1 Module with Gate Control**” chapter for more information on configuring Timer1.

27.2.3 Software Interrupt Mode

When the Capture mode is changed, a false capture interrupt may be generated. The user will keep the CCPxIE Interrupt Enable bit of the PIE_x register clear to avoid false interrupts. Additionally, the user will clear the CCPxIF Interrupt Flag bit of the PIR_x register following any change in Operating mode.



Important: Clocking Timer1 from the system clock (F_{OSC}) must not be used in Capture mode. For Capture mode to recognize the trigger event on the CCP_x pin, Timer1 must be clocked from the instruction clock ($F_{OSC}/4$) or from an external clock source.

27.2.4 CCP Prescaler

There are four prescaler settings specified by the **MODE** bits. Whenever the CCP module is turned off or when the CCP module is not in Capture mode, the prescaler counter is cleared. Any Reset will clear the prescaler counter.

Switching from one capture prescaler to another does not clear the prescaler and may generate a false interrupt. To avoid this unexpected operation, turn the module off by clearing the CCP_xCON register before changing the prescaler. The example below demonstrates the code to perform this function.

Example 27-1. Changing between Capture Prescalers

```
BANKSEL CCP1CON      ;only needed when CCP1CON is not in ACCESS space
CLRFB CCP1CON        ;Turn CCP module off
MOVLW  NEW_CAPT_PS   ;CCP ON and Prescaler select → W
MOVWF  CCP1CON        ;Load CCP1CON with this value
```

27.2.5 Capture During Sleep

Capture mode depends upon the Timer1 module for proper operation. There are two options for driving the Timer1 module in Capture mode. It can be driven by the instruction clock ($F_{OSC}/4$) or by an external clock source.

When Timer1 is clocked by $F_{OSC}/4$, Timer1 will not increment during Sleep. When the device wakes from Sleep, Timer1 will continue from its previous state.

Capture mode will operate during Sleep when Timer1 is clocked by an external clock source.

27.3 Compare Mode

The Compare mode function described in this section is available and identical for all CCP modules.

Compare mode makes use of the 16-bit odd numbered Timer resources (Timer1, Timer3, etc.). The 16-bit value of the **CCPR_x** register is constantly compared against the 16-bit value of the TMR_x register. When a match occurs, one of the following events can occur:

- Toggle the CCP_x output and clear TMR_x
- Toggle the CCP_x output without clearing TMR_x
- Set the CCP_x output
- Clear the CCP_x output
- Generate a Pulse output
- Generate a Pulse output and clear TMR_x

The action on the pin is based on the value of the **MODE** control bits.

All Compare modes can generate an interrupt. When $MODE = \text{'b}0001$ or $\text{'b}1011$, the CCP resets the TMRx register.

The following figure shows a simplified diagram of the compare operation.

Figure 27-2. Compare Mode Operation Block Diagram

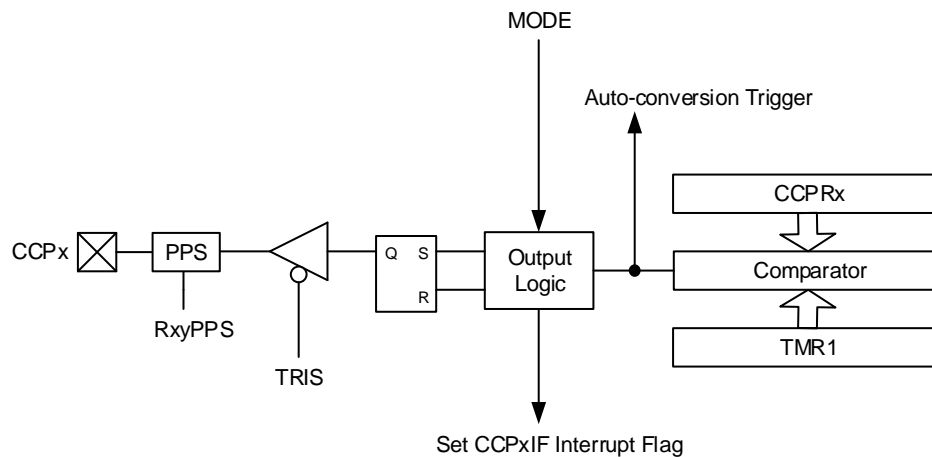

27.3.1 CCPx Pin Configuration

The CCPx pin must be configured as an output in software by clearing the associated TRIS bit and defining the appropriate output pin through the RxyPPS registers. See the **“PPS - Peripheral Pin Select Module”** chapter for more details.

The CCP output can also be used as an input for other peripherals.



Important: Clearing the CCPxCON register will force the CCPx compare output latch to the default low level. This is not the PORT I/O data latch.

27.3.2 Timer1 Mode for Compare

In Compare mode, Timer1 must be running in either Timer mode or Synchronized Counter mode. The compare operation may not work in Asynchronous Counter mode.

See the **“TMR1 - Timer1 Module with Gate Control”** chapter for more information on configuring Timer1.



Important: Clocking Timer1 from the system clock (F_{OSC}) must not be used in Compare mode. For Compare mode to recognize the trigger event on the CCPx pin, Timer1 must be clocked from the instruction clock ($F_{OSC}/4$) or from an external clock source.

27.3.3 Compare During Sleep

Since F_{OSC} is shut down during Sleep mode, the Compare mode will not function properly during Sleep, unless the timer is running. The device will wake on interrupt (if enabled).

27.4 PWM Overview

Pulse-Width Modulation (PWM) is a scheme that controls power to a load by switching quickly between fully ON and fully OFF states. The PWM signal resembles a square wave where the high

portion of the signal is considered the ON state and the low portion of the signal is considered the OFF state. The high portion, also known as the pulse width, can vary in time and is defined in steps. A larger number of steps applied, which lengthens the pulse width, also supplies more power to the load. Lowering the number of steps applied, which shortens the pulse width, supplies less power. The PWM period is defined as the duration of one complete cycle or the total amount of ON and OFF time combined.

PWM resolution defines the maximum number of steps that can be present in a single PWM period. A higher resolution allows for more precise control of the power applied to the load.

The term duty cycle describes the proportion of the ON time to the OFF time and is expressed in percentages, where 0% is fully OFF and 100% is fully ON. A lower duty cycle corresponds to less power applied and a higher duty cycle corresponds to more power applied. The figure below shows a typical waveform of the PWM signal.

Figure 27-3. CCP PWM Output Signal

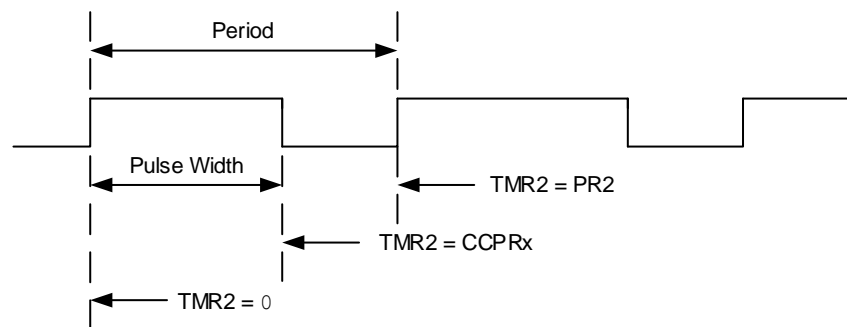

27.4.1 Standard PWM Operation

The standard PWM function described in this section is available and identical for all CCP modules. It generates a Pulse-Width Modulation (PWM) signal on the CCPx pin with up to ten bits of resolution. The period, duty cycle and resolution are controlled by the following registers:

- Even numbered TxPR registers (T2PR, T4PR, etc.)
- Even numbered TxCON registers (T2CON, T4CON, etc.)
- 16-bit CCPRx registers
- CCPxCON registers

It is required to have $F_{OSC}/4$ as the clock input to TxTMR for correct PWM operation. The following figure shows a simplified block diagram of the PWM operation.

Figure 27-4. Simplified PWM Block Diagram

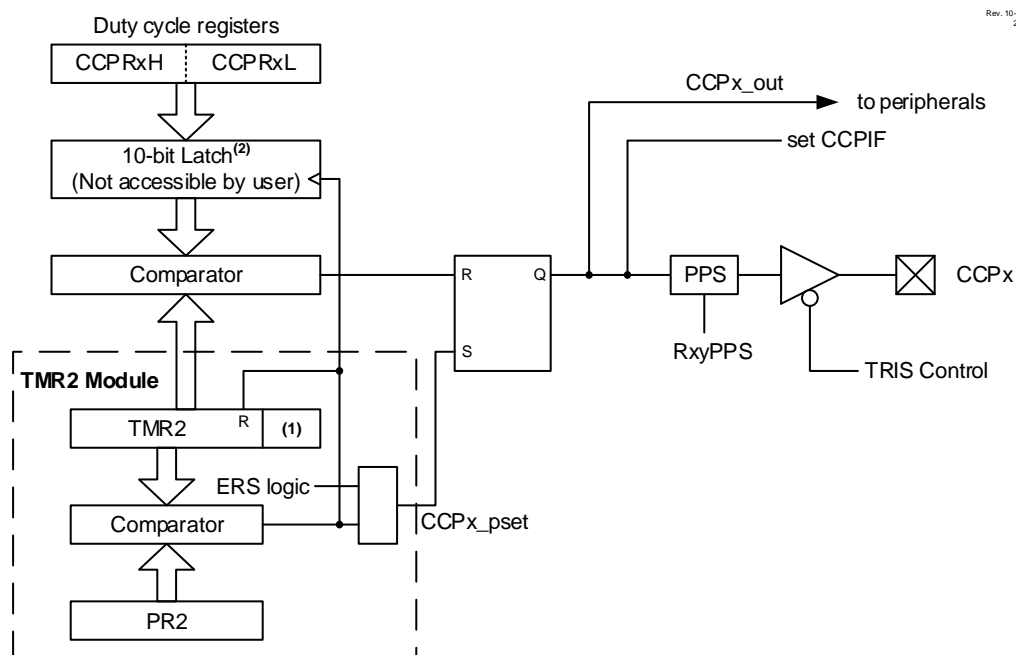

- Notes:**
1. An 8-bit timer is concatenated with two bits generated by F_{osc} or two bits of the internal prescaler to create 10-bit time base.
 2. The alignment of the 10 bits from the CCPR register is determined by the CCPxFMT bit.



Important: The corresponding TRIS bit must be cleared to enable the PWM output on the CCPx pin.

27.4.2 Setup for PWM Operation

The following steps illustrate how to configure the CCP module for standard PWM operation:

1. Select the desired output pin with the RxyPPS control to select CCPx as the source. Disable the selected pin output driver by setting the associated TRIS bit. The output will be enabled later at the end of the PWM setup.
2. Load the selected timer TxPR period register with the PWM period value.
3. Configure the CCP module for the PWM mode by loading the CCPxCON register with the appropriate values.
4. Load the CCPRx register with the PWM duty cycle value and configure the FMT bit to set the proper register alignment.
5. Configure and start the selected timer:
 - Clear the TMRxIF Interrupt Flag bit of the PIRx register. See the Important Note below.
 - Select the timer clock source to be as $F_{OSC}/4$. This is required for correct operation of the PWM module.
 - Configure the TxCKPS bits of the TxCON register with the desired timer prescale value.
 - Enable the timer by setting the TxON bit.
6. Enable the PWM output:

- Wait until the timer overflows and the TMRxIF bit of the PIRx register is set. See the Important Note below.
- Enable the CCPx pin output driver by clearing the associated TRIS bit.



Important: To send a complete duty cycle and period on the first PWM output, the above steps must be included in the setup sequence. If it is not critical to start with a complete PWM signal on the first output, then step 6 may be ignored.

27.4.3 Timer2 Timer Resource

The PWM Standard mode makes use of the 8-bit Timer2 timer resources to specify the PWM period.

27.4.4 PWM Period

The PWM period is specified by the T2PR register of Timer2. The PWM period can be calculated using the formula in the equation below.

Equation 27-1. PWM Period

$$PWM\ Period = [(T2PR + 1)] \cdot 4 \cdot T_{OSC} \cdot (TMR2\ Prescale\ Value)$$

where $T_{OSC} = 1/F_{OSC}$

When T2TMR is equal to T2PR, the following three events occur on the next increment event:

- T2TMR is cleared
- The CCPx pin is set (Exception: If the PWM duty cycle = 0%, the pin will not be set)
- The PWM duty cycle is transferred from the CCPRx register into a 10-bit buffer



Important: The Timer postscaler (see the “**Timer2 Interrupt**” section in the “**TMR2 - Timer2 Module**” chapter) is not used in the determination of the PWM frequency.

27.4.5 PWM Duty Cycle

The PWM duty cycle is specified by writing a 10-bit value to the CCPRx register. The alignment of the 10-bit value is determined by the FMT bit (see [Figure 27-5](#)). The CCPRx register can be written to at any time. However, the duty cycle value is not latched onto the 10-bit buffer until after a match between T2PR and T2TMR.

The equations below are used to calculate the PWM pulse width and the PWM duty cycle ratio.

Figure 27-5. PWM 10-Bit Alignment

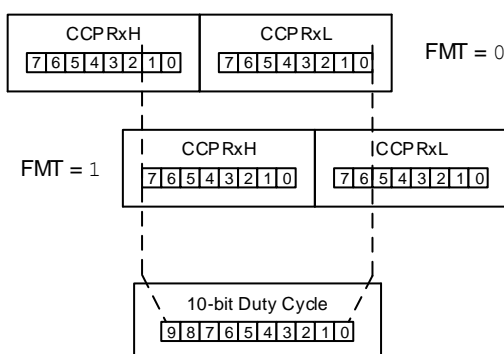
**Equation 27-2.** Pulse Width

$$\text{Pulse Width} = (\text{CCPRxH:CCPRxL register value}) \cdot T_{OSC} \cdot (\text{TMR2 Prescale Value})$$

Equation 27-3. Duty Cycle

$$\text{DutyCycleRatio} = \frac{(\text{CCPRxH:CCPRxL register value})}{4(\text{T2PR} + 1)}$$

The CCPRx register is used to double buffer the PWM duty cycle. This double buffering is essential for glitchless PWM operation.

The 8-bit timer T2TMR register is concatenated with either the 2-bit internal system clock (F_{OSC}), or two bits of the prescaler, to create the 10-bit time base. The system clock is used if the Timer2 prescaler is set to 1:1.

When the 10-bit time base matches the CCPRx register, then the CCPx pin is cleared (see [Figure 27-4](#)).

27.4.6 PWM Resolution

The resolution determines the number of available duty cycles for a given period. For example, a 10-bit resolution will result in 1024 discrete duty cycles, whereas an 8-bit resolution will result in 256 discrete duty cycles.

The maximum PWM resolution is 10 bits when T2PR is 0xFF. The resolution is a function of the T2PR register value, as shown below.

Equation 27-4. PWM Resolution

$$\text{Resolution} = \frac{\log[4(\text{T2PR} + 1)]}{\log(2)} \text{ bits}$$



Important: If the pulse-width value is greater than the period, the assigned PWM pin(s) will remain unchanged.

Table 27-2. Example PWM Frequencies and Resolutions ($F_{OSC} = 20 \text{ MHz}$)

PWM Frequency	1.22 kHz	4.88 kHz	19.53 kHz	78.12 kHz	156.3 kHz	208.3 kHz
Timer Prescale	16	4	1	1	1	1
T2PR Value	0xFF	0xFF	0xFF	0x3F	0x1F	0x17

.....continued						
PWM Frequency	1.22 kHz	4.88 kHz	19.53 kHz	78.12 kHz	156.3 kHz	208.3 kHz
Maximum Resolution (bits)	10	10	10	8	7	6.6

Table 27-3. Example PWM Frequencies and Resolutions ($F_{OSC} = 8 \text{ MHz}$)

PWM Frequency	1.22 kHz	4.90 kHz	19.61 kHz	76.92 kHz	153.85 kHz	200.0 kHz
Timer Prescale	16	4	1	1	1	1
T2PR Value	0x65	0x65	0x65	0x19	0x0C	0x09
Maximum Resolution (bits)	8	8	8	6	5	5

27.4.7 Operation in Sleep Mode

In Sleep mode, the T2TMR register will not increment and the state of the module will not change. If the CCPx pin is driving a value, it will continue to drive that value. When the device wakes up, T2TMR will continue from the previous state.

27.4.8 Changes in System Clock Frequency

The PWM frequency is derived from the system clock frequency. Any changes in the system clock frequency will result in changes to the PWM frequency. See the **“OSC - Oscillator Module (With Fail-Safe Clock Monitor)”** chapter for additional details.

27.4.9 Effects of Reset

Any Reset will force all ports to Input mode and the CCP registers to their Reset states.

27.5 Register Definitions: CCP Control

Long bit name prefixes for the CCP peripherals are shown in the following table. Refer to the **“Long Bit Names”** section in the **“Register and Bit Naming Conventions”** chapter for more information.

Table 27-4. CCP Long Bit Name Prefixes

Peripheral	Bit Name Prefix
CCP1	CCP1
CCP2	CCP2

27.5.1 CCPxCON

Name: CCPxCON
Offset: 0x040E,0x0412

CCP Control Register

Bit	7	6	5	4	3	2	1	0
	EN		OUT	FMT	MODE[3:0]			
Access	R/W		R	R/W	R/W	R/W	R/W	R/W
Reset	0		x	0	0	0	0	0

Bit 7 – EN CCP Module Enable

Value	Description
1	CCP is enabled
0	CCP is disabled

Bit 5 – OUT CCP Output Data (read-only)

Bit 4 – FMT CCPxRH:L Value Alignment (PWM mode)

Value	Condition	Description
x	Capture mode	Not used
x	Compare mode	Not used
1	PWM mode	Left aligned format
0	PWM mode	Right aligned format

Bits 3:0 – MODE[3:0] CCP Mode Select

Table 27-5. CCPx Mode Select

MODE Value	Operating Mode	Operation	Set CCPxIF
11xx	PWM	PWM operation	Yes
1011	Compare	Pulse output; clear TMR1 ⁽²⁾	Yes
1010		Pulse output	Yes
1001		Clear output ⁽¹⁾	Yes
1000		Set output ⁽¹⁾	Yes
0111		Capture	Every 16 th rising edge of CCPx input
0110	Every 4 th rising edge of CCPx input		Yes
0101	Every rising edge of CCPx input		Yes
0100	Every falling edge of CCPx input		Yes
0011	Every edge of CCPx input		Yes
0010	Compare	Toggle output	Yes
0001		Toggle output; clear TMR1 ⁽²⁾	Yes
0000	Disabled		—

Notes:

1. The set and clear operations of the Compare mode are reset by setting MODE = 'b0000 or EN = 0.
2. When MODE = 'b0001 or 'b1011, then the timer associated with the CCP module is cleared. TMR1 is the default selection for the CCP module, so it is used for indication purposes only.

27.5.2 CCPxCAP

Name: CCPxCAP
Offset: 0x040F,0x0413

Capture Trigger Input Selection Register

Bit	7	6	5	4	3	2	1	0
					CTS[3:0]			
Access					R/W	R/W	R/W	R/W
Reset					0	0	0	0

Bits 3:0 – CTS[3:0] Capture Trigger Input Selection

Table 27-6. Capture Trigger Sources

CTS Value	Source
1111–1000	Reserved
0111	CLC4_OUT
0110	CLC3_OUT
0101	CLC2_OUT
0100	CLC1_OUT
0011	IOC Interrupt
0010	C2_OUT
0001	C1_OUT
0000	Pin selected by CCPxPPS

27.5.3 CCPRx

Name: CCPRx
Offset: 0x040C,0x0410

Capture/Compare/Pulse-Width Register

Bit	15	14	13	12	11	10	9	8
	CCPR[15:8]							
Access	R/W	R/W	R/W	R/W	R/W	R/W	R/W	R/W
Reset	x	x	x	x	x	x	x	x
Bit	7	6	5	4	3	2	1	0
	CCPR[7:0]							
Access	R/W	R/W	R/W	R/W	R/W	R/W	R/W	R/W
Reset	x	x	x	x	x	x	x	x

Bits 15:0 – CCPR[15:0] Capture/Compare/Pulse-Width

Reset States: POR/BOR = xxxxxxxxxxxxxxxxx

All other Resets = uuuuuuuuuuuuuuuuu

Notes: The individual bytes in this multibyte register can be accessed with the following register names:

- When MODE = Capture or Compare
 - CCPRxH: Accesses the high byte CCPR[15:8]
 - CCPRxL: Accesses the low byte CCPR[7:0]
- When MODE = PWM and FMT = 0
 - CCPRx[15:10]: Not used
 - CCPRxH[1:0]: Accesses the two Most Significant bits CCPR[9:8]
 - CCPRxL: Accesses the eight Least Significant bits CCPR[7:0]
- When MODE = PWM and FMT = 1
 - CCPRxH: Accesses the eight Most Significant bits CCPR[9:2]
 - CCPRxL[7:6]: Accesses the two Least Significant bits CCPR[1:0]
 - CCPRx[5:0]: Not used

27.6 Register Summary - CCP Control

Offset	Name	Bit Pos.	7	6	5	4	3	2	1	0
0x00 ... 0x040B	Reserved									
0x040C	CCPR1	7:0	CCPR[7:0]							
		15:8	CCPR[15:8]							
0x040E	CCP1CON	7:0	EN		OUT	FMT			MODE[3:0]	
0x040F	CCP1CAP	7:0							CTS[3:0]	
0x0410	CCPR2	7:0	CCPR[7:0]							
		15:8	CCPR[15:8]							
0x0412	CCP2CON	7:0	EN		OUT	FMT			MODE[3:0]	
0x0413	CCP2CAP	7:0							CTS[3:0]	

28. Capture, Compare, and PWM Timers Selection

Each of these modules has an independent timer selection which can be accessed using the timer selection register. The default timer selection is Timer1 for capture or compare functions and Timer2 for PWM functions.

28.1 Register Definitions: Capture, Compare, and PWM Timers Selection

28.1.1 CCPTMRS0

Name: CCPTMRS0
Offset: 0x041F

CCP Timers Selection Register

Bit	7	6	5	4	3	2	1	0
					C2TSEL[1:0]		C1TSEL[1:0]	
Access					R/W	R/W	R/W	R/W
Reset					0	1	0	1

Bits 0:1, 2:3 – CnTSEL CCPn Timer Selection

CnTSEL Value	Capture/Compare	PWM
11	Reserved	
10	Timer3	Timer4
01	Timer1	Timer2
00	Reserved	

28.2 Register Summary - Capture, Compare, and PWM Timers Selection

Offset	Name	Bit Pos.	7	6	5	4	3	2	1	0
0x00	Reserved									
...										
0x041E										
0x041F	CCPTMRS0	7:0					C2TSEL[1:0]		C1TSEL[1:0]	

29. PWM - Pulse-Width Modulator with Compare

This module is a 16-bit Pulse-Width Modulator (PWM) with a compare feature and multiple outputs. The outputs are grouped in slices where each slice has two outputs. There can be up to four slices in each PWM module. The **EN** bit enables the PWM operation for all slices simultaneously. The prescale counter, postscale counter, and all internal logic is held in Reset while the EN bit is low.

Features of this module include the following:

- Five main operating modes:
 - Left Aligned
 - Right Aligned
 - Center-Aligned
 - Variable Aligned
 - Compare
 - Pulsed
 - Toggled
- Push-pull operation (available in Left and Right Aligned modes only)
- Independent 16-bit period timer
- Programmable clock sources
- Programmable trigger sources for synchronous duty cycle and period changes
- Programmable synchronous/asynchronous Reset sources
- Programmable Reset source polarity control
- Programmable PWM output polarity control
- Up to four two-output slices per module

Block diagrams of each PWM mode are shown in their respective sections.

29.1 Output Slices

A PWM module can have up to four output slices. An output slice consists of two PWM outputs, **PWMx_SaP1_out** and **PWMx_SaP2_out**. Both share the same operating mode. However, other slices may operate in a different mode. **PWMx_SaP1_out** and **PWMx_SaP2_out** have independent duty cycles which are set with the respective **P1** and **P2** parameter registers.

29.1.1 Output Polarity

The polarity for the **PWMx_SaP1_out** and **PWMx_SaP2_out** is controlled with the respective **POL1** and **POL2** bits. Setting the polarity bit inverts the output Active state to Low True. Toggling the polarity bit toggles the output whether or not the PWM module is enabled.

29.1.2 Operating Modes

Each output slice can operate in one of six modes selected with the **MODE** bits. The Left and Right Aligned modes can also be operated in Push-Pull mode by setting the **PPEN** bit. The following sections provide more details on each mode, including block diagrams.

29.1.2.1 Left Aligned Mode

In Left Aligned mode, the active part of the duty cycle is at the beginning of the period. The outputs start active and stay active for the number of prescaled PWM clock periods specified by the P1 and P2 parameter registers, then go inactive for the remainder of the period. Block and timing diagrams follow.

Figure 29-1. Left-Aligned Block Diagram

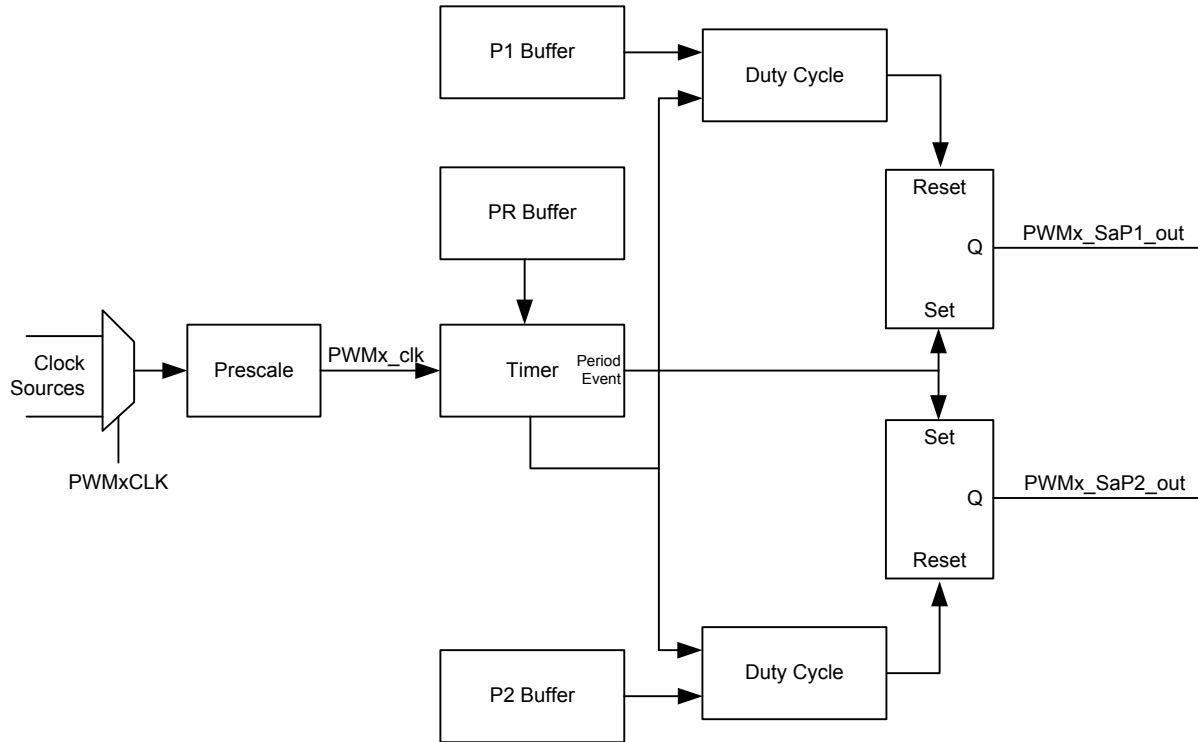
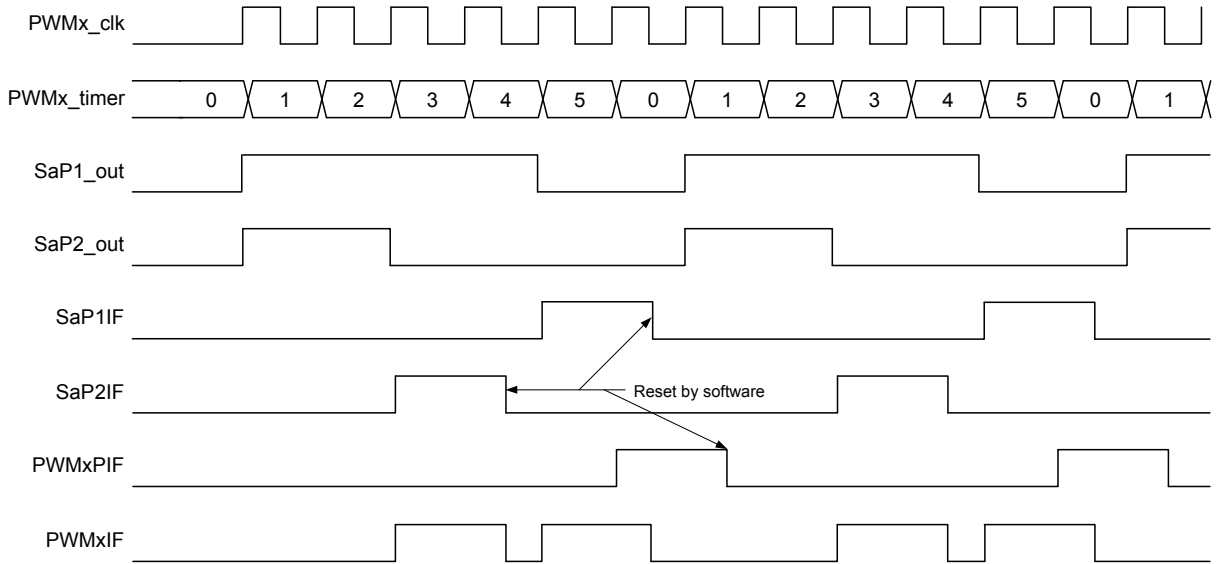

Figure 29-2. Left-Aligned Timing Diagram



Note: MODE = 'b000 , PR = 5, P1 = 4, P2 = 2.

29.1.2.2 Right Aligned Mode

In Right Aligned mode, the active part of the duty cycle is at the end of the period. The outputs start in the Inactive state and then go Active the number of prescaled PWM clock periods specified by the P1 and P2 parameter registers before the end of the period. Block and timing diagrams follow.

Figure 29-3. Right-Aligned Block Diagram

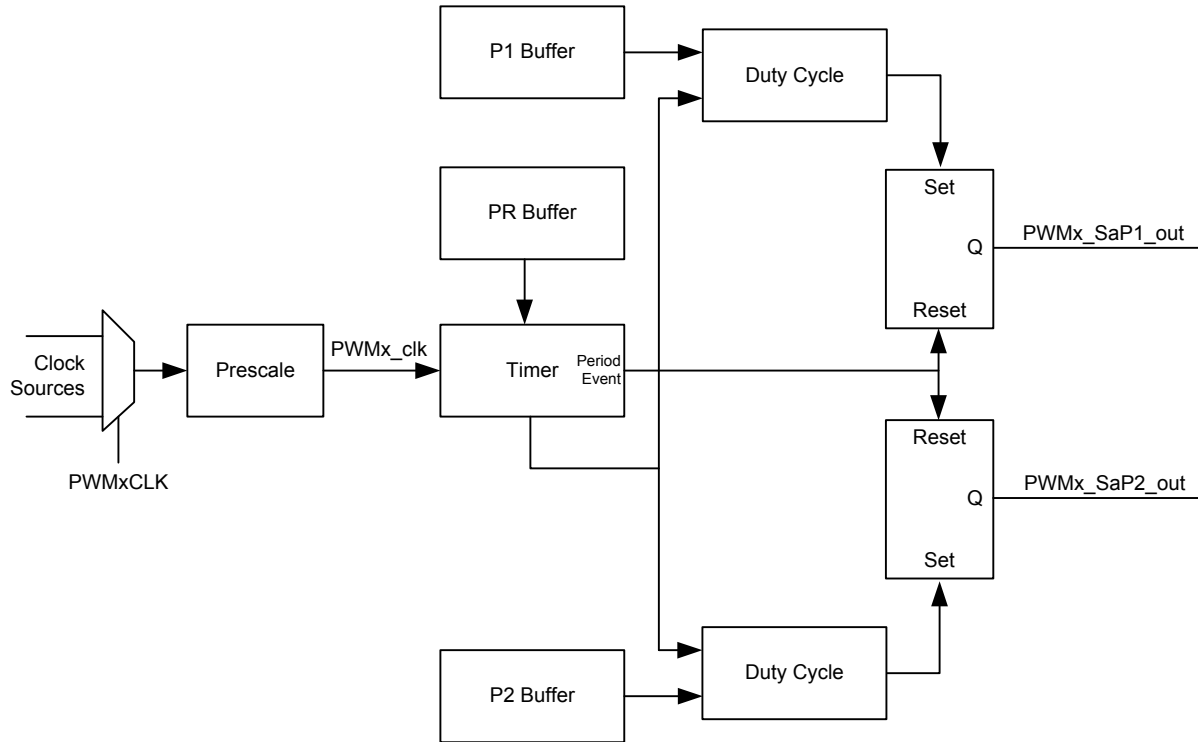
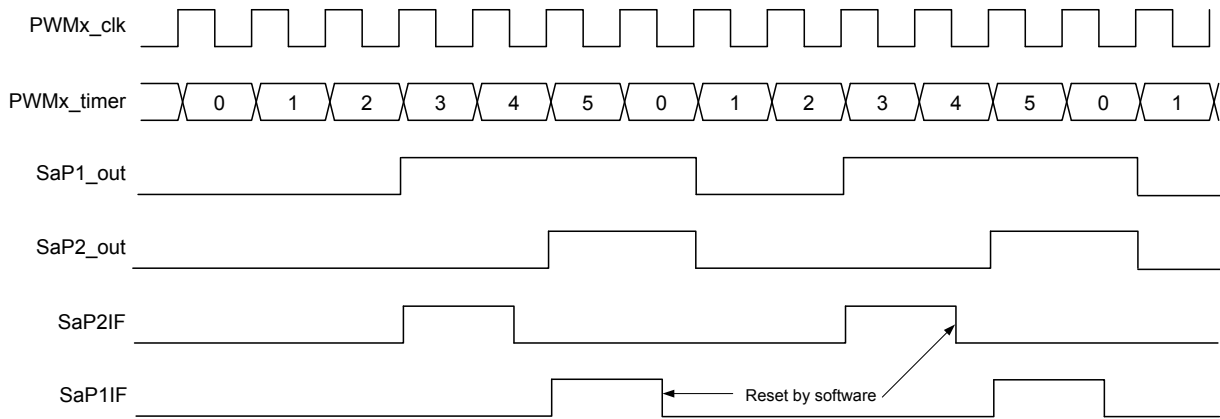

Figure 29-4. Right-Aligned Timing Diagram



Note: MODE = 'b001, PR = 5, P1 = 4, P2 = 2.

29.1.2.3 Center-Aligned Mode

In Center-Aligned mode, the active duty cycle is centered in the period. The period for this mode is twice that of other modes, as shown in the following equation.

Equation 29-1. Center-Aligned Period

$$Period = \frac{(PR + 1) \times 2}{F_{PWMx_clk}}$$

The parameter register specifies the number of PWM clock periods that the output goes Active before the period center. The output goes inactive the same number of prescaled PWM clock periods after the period center. Block and timing diagrams follow.

Figure 29-5. Center-Aligned Block Diagram

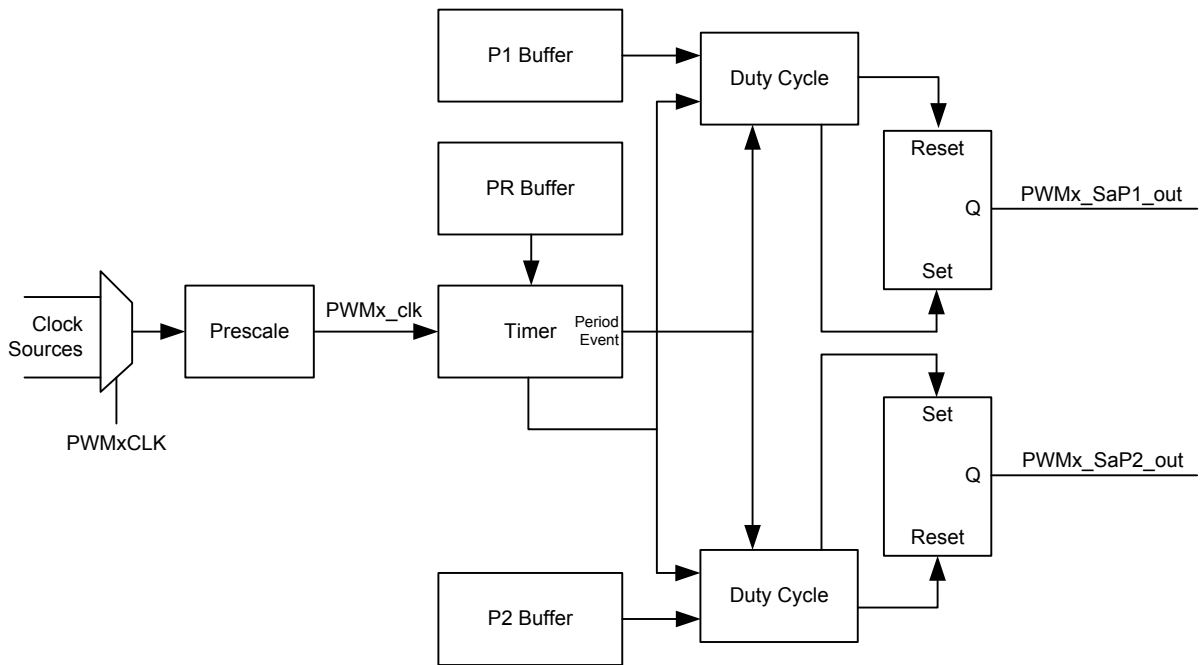
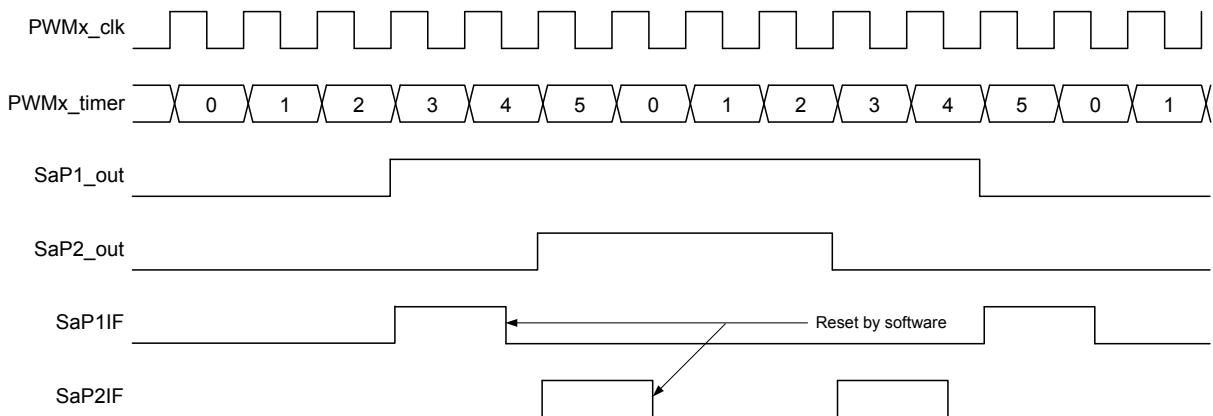

Figure 29-6. Center-Aligned Timing Diagram



Note: MODE = 'b010, PR = 5, P1 = 4, P2 = 2.

29.1.2.4 Variable Alignment Mode

In Variable Alignment mode, the active part of the duty cycle starts when the parameter 1 value (P1) matches the timer and ends when the parameter 2 value (P2) matches the timer. Both outputs are identical because both parameter values are used for the same duty cycle. Block and timing diagrams follow.

Figure 29-7. Variable Alignment Block Diagram

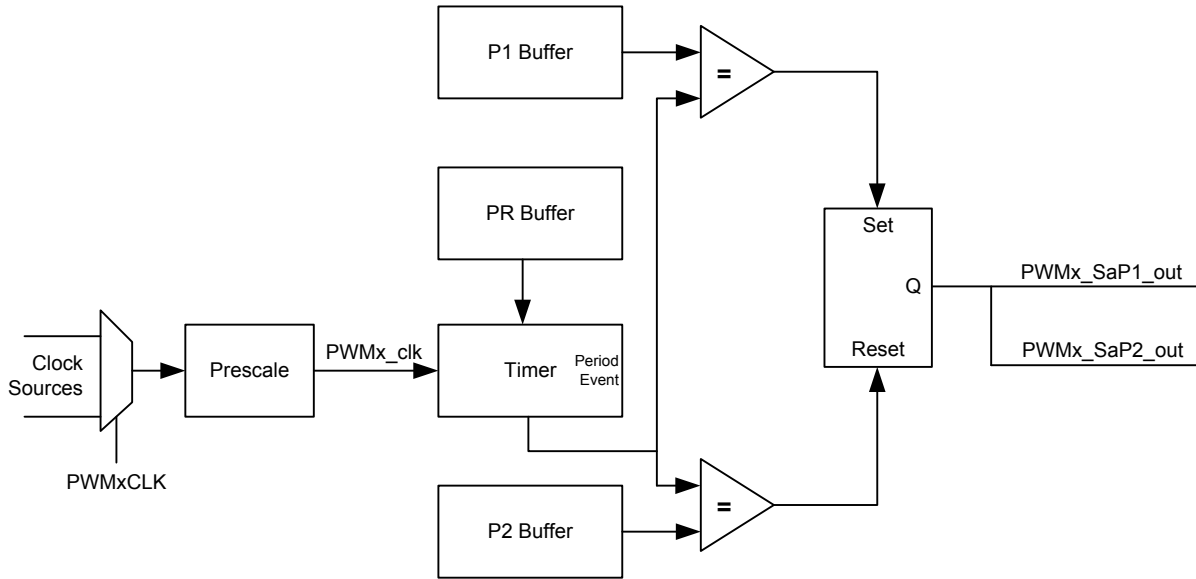
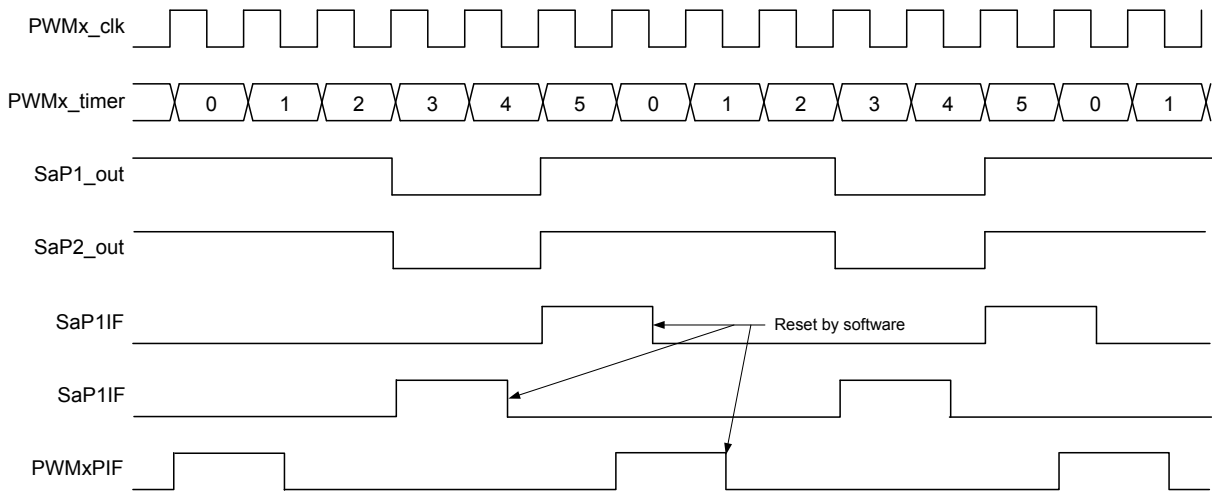

Figure 29-8. Variable Alignment Timing Diagram



Note: MODE = 'b011, PR = 5, P1 = 4, P2 = 2.

29.1.2.5 Compare Modes

In the Compare modes, the PWM timer is compared to the P1 and P2 parameter values. When a match occurs, the output is either pulsed or toggled. In Pulsed Compare mode, the duty cycle is always one prescaled PWM clock period. In Toggle Compare mode, the duty cycle is always one full PWM period. Refer to the following sections for more details.

29.1.2.5.1 Pulsed Compare Mode

In Pulsed Compare mode, the duty cycle is one prescaled PWM clock period that starts when the timer matches the parameter value and ends one prescaled PWM clock period later. The outputs start in the Inactive state and then go Active during the duty cycle. Block and timing diagrams follow.

Figure 29-9. Pulsed Compare Block Diagram

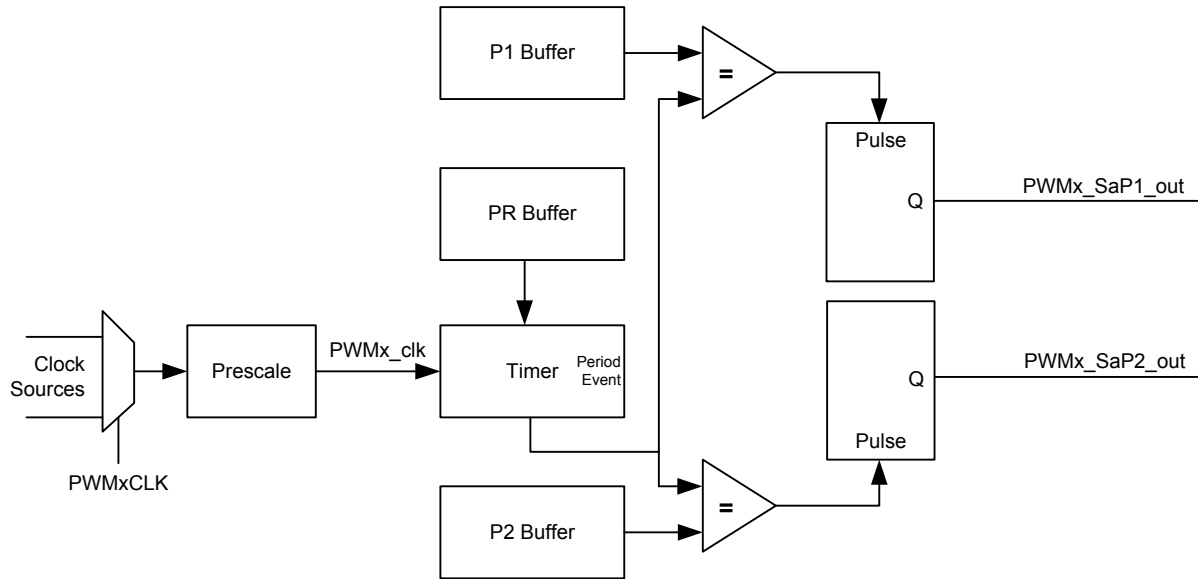
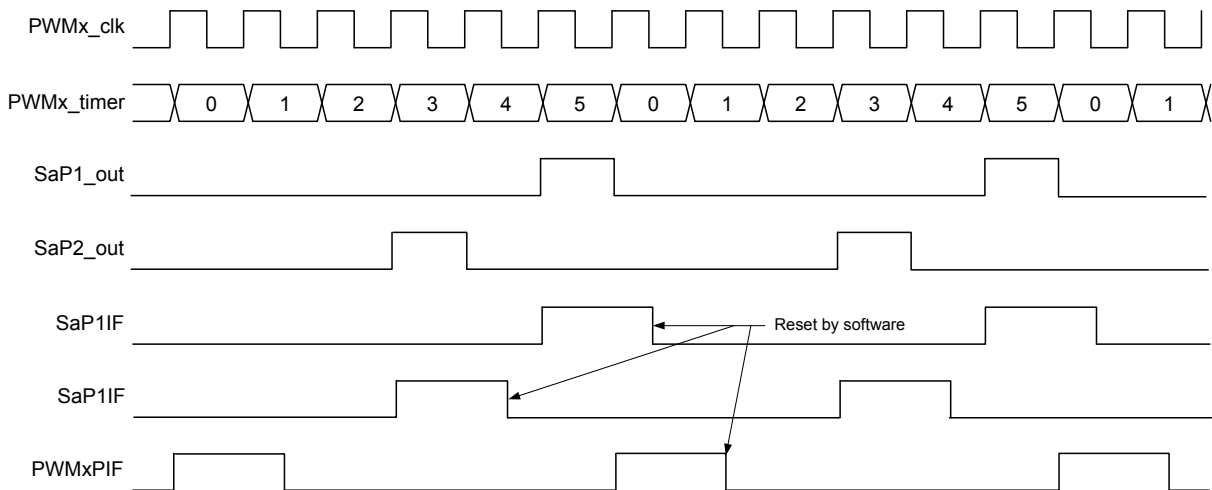

Figure 29-10. Pulsed Compare Timing Diagram



Note: MODE = 'b100, PR = 5, P1 = 4, P2 = 2.

29.1.2.5.2 Toggled Compare

In Toggled Compare mode, the duty cycle is alternating full PWM periods. The output goes Active when the PWM timer matches the P1 or P2 parameter value and goes Inactive in the next period at the same match point. Block and timing diagrams follow.

Figure 29-11. Toggled Compare Block Diagram

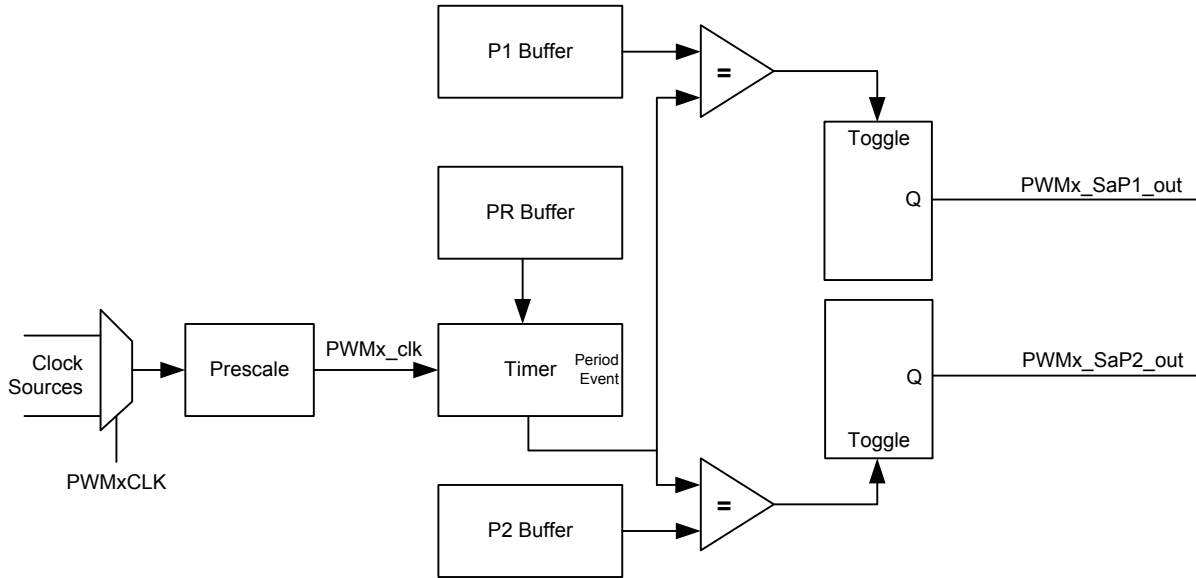
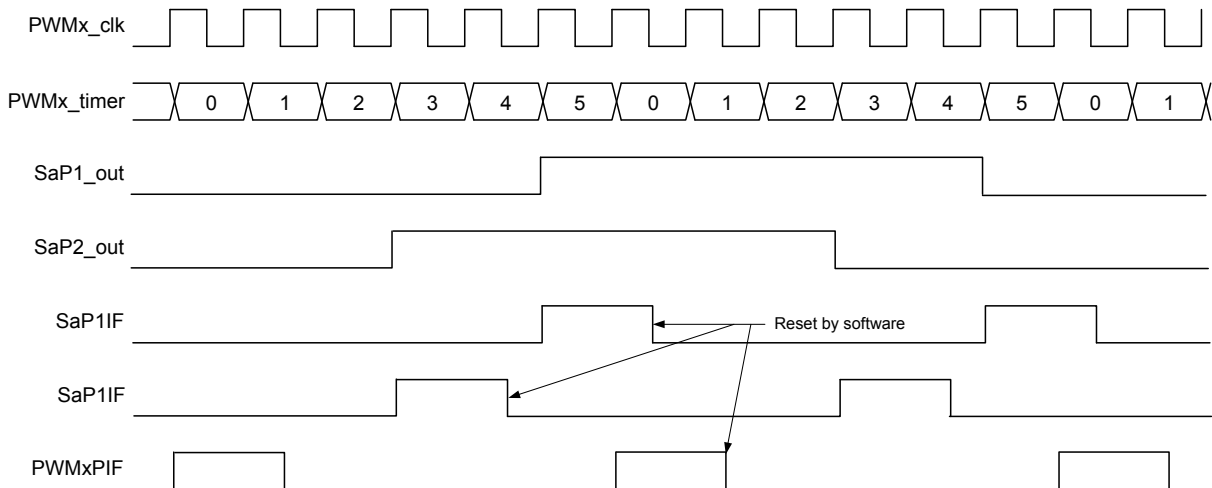

Figure 29-12. Toggled Compare Timing Diagram



Note: MODE = 'b101, PR = 5, P1 = 4, P2 = 2.

29.1.3 Push-Pull Mode

The Push-Pull mode is enabled by setting the **PPEN** bit. Push-Pull operates only in the Left Aligned and Right Aligned modes. In the Push-Pull mode, the outputs are Active every other PWM period. PWMx_SaP1_out is Active when the PWMx_SaP2_out is not and the PWMx_SaP2_out is Active when the PWMx_SaP1_out is not. When the parameter value (P1 or P2) is greater than the period value (PR), then the corresponding output is Active for one full PWM period. The following figures illustrate timing examples of Left and Right Aligned Push-Pull modes.

Figure 29-13. Left Aligned Push-Pull Mode Timing Diagram

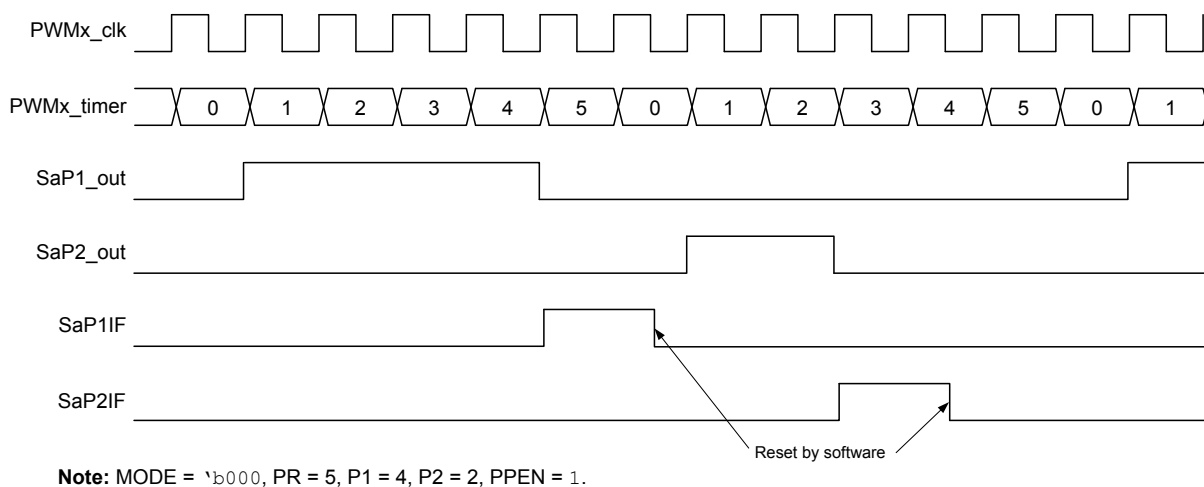
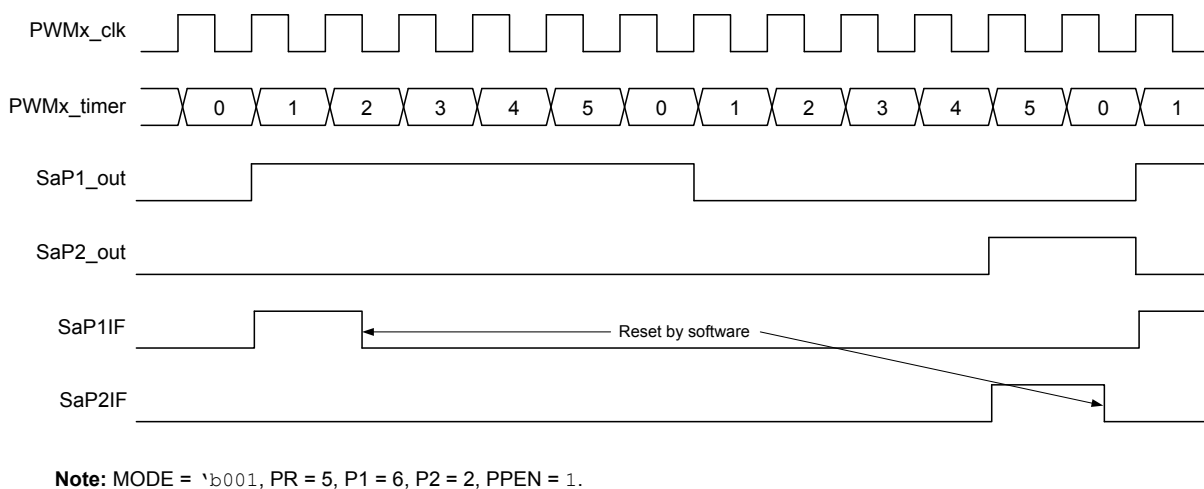

Figure 29-14. Right Aligned Push-Pull Mode Timing Diagram



29.2 Period Timer

All slices in a PWM instance operate with the same period. The value written to the **PWMxPR** register is one less than the number of prescaled PWM clock periods (PWM_clk) in the PWM period.

The PWMxPR register is double-buffered. When the PWM is operating, writes to the PWMxPR register are transferred to the period buffer only after the **LD** bit is set or an external load event occurs. The transfer occurs at the next period Reset event. If the LD bit is set less than three PWM clock periods before the end of the period, then the transfer may be one full period later.

Loading the buffers of multiple PWM instances can be coordinated using the PWMLOAD register. See the [Buffered Period and Parameter Registers](#) section for more details.

29.3 Clock Sources

The time base for the PWM period prescaler is selected with the [CLK](#) bits. Changes take effect immediately when written. Clearing the EN bit before making clock source changes is recommended to avoid unexpected behavior.

29.3.1 Clock Prescaler

The PWM clock frequency can be reduced with the clock prescaler. There are 256 prescale selections from 1:1 to 1:256.

The [CPRE](#) bits select the prescale value. Changes to the prescale value take effect immediately. Clearing the EN bit before making prescaler changes is recommended to avoid unexpected behavior. The prescale counter is reset when the EN bit is cleared.

29.4 External Period Resets

The period timer can be reset and held at zero by a logic level from one of various sources. The Reset event also resets the postscaler counter. The resetting source is selected with the [ERS](#) bits.

The Reset can be configured with the [ERSNOW](#) bit to occur on either the next PWM clock or the next PWM period Reset event. When the ERSNOW bit is set, then the Reset will occur on the next PWM clock. When the ERSNOW bit is cleared, then the Reset will be held off until the timer resets at the end of the period. The difference between a normal period Reset and an ERS Reset is that once the timer is reset, it is held at zero until the ERS signal goes false. The following timing diagrams illustrate the two types of external Reset.

Figure 29-15. Right Aligned Mode with ERSNOW = 1

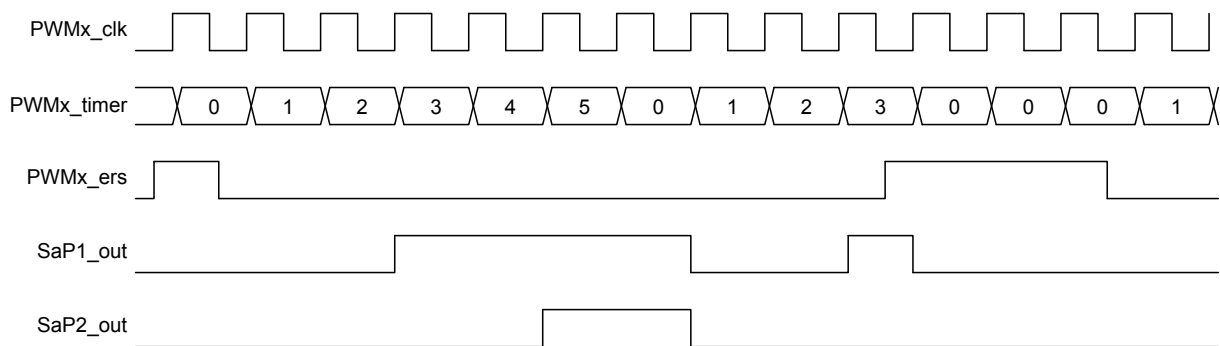

Note: PR = 5, P1 = 4, P2 = 2.

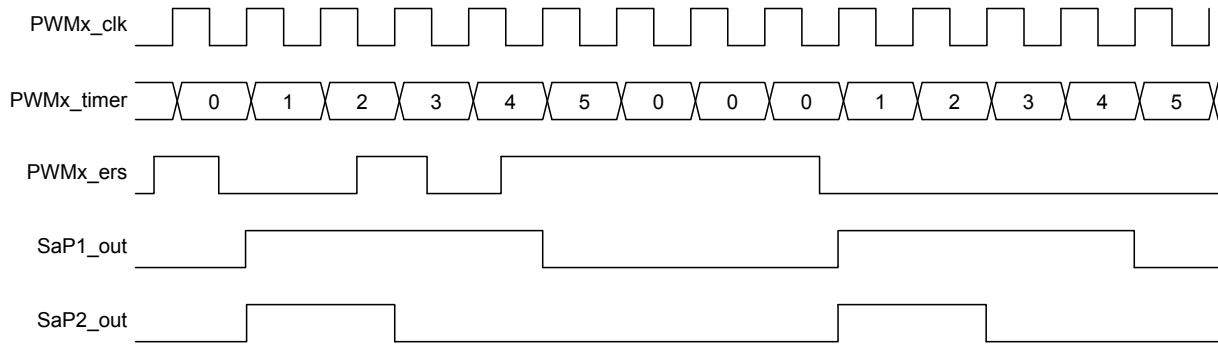
Figure 29-16. Left Aligned Mode with ERSNOW = 0

Note: PR = 5, P1 = 4, P2 = 2.

29.5 Buffered Period and Parameter Registers

The PWMxPR, PWMxSaP1 and PWMxSaP2 registers are double-buffered. The PWM module operates on the buffered copies. The values in all these registers are copied to the buffer registers when the PWM module is enabled.

Changes to the PWMxPR, PWMxSaP1 and PWMxSaP2 registers do not affect the buffer registers while the PWM is operating until either software sets the **LD** bit or an external load event occurs. For all operating modes except Center-Aligned, the values are copied to the buffer registers when the PWM timer is reloaded at the end of the period in which the load request occurred. In the Center-Aligned mode, the buffer update occurs on every other period Reset event because one full center-aligned period uses two period cycles. Load requests occurring three or less clocks before the end of the period may not be serviced until the following period.

A list of external load trigger sources is shown in the **PWMxLDS** register. Software can set the LD bits of multiple PWM instances simultaneously with the **PWMLoad** register.



Important: No changes are allowed after the LD bit is set until after the LD bit is cleared by hardware. Unexpected behavior may result if the LD bit is cleared by software.

29.6 Synchronizing Multiple PWMs

To synchronize multiple PWMs, the **PWMEN** register is used to enable selected PWMs simultaneously. The bits in the PWMEN register are mirror copies of the EN bit of every PWM in the device. Setting or clearing the EN bits in the PWMEN register enables or disables all the corresponding PWMs simultaneously.

29.7 Interrupts

Each PWM instance has a period interrupt and interrupts associated with the mode and parameter settings.

29.7.1 Period Interrupt

The period interrupt occurs when the PWMx timer value matches the PR value, thereby also resetting the PWMx timer. Refer to [Figure 29-2](#) for a timing example. The period interrupt is indicated with the PWMxPIF flag bit in one of the PIR registers and is set whether or not the interrupt is enabled. This flag must be reset by software. The PWMxPIF interrupt is enabled with the PWMxPIE bit in the corresponding PIE register.

29.7.1.1 Period Interrupt Postscaler

The frequency of the period interrupt events can be reduced with the period interrupt postscaler. A postscaler counter suppresses period interrupts until the postscale count is reached. Only one PWM period interrupt is generated for every postscale counts. There are 256 postscale selections from 1:1 to 1:256.

The **PIPOS** bits select the postscale value. Changes to the postscale value take effect immediately. Clearing the EN bit before making postscaler changes is recommended to avoid unexpected behavior. The postscale counter is reset when the EN bit is cleared.

29.7.2 Parameter Interrupts

The P1 and P2 parameters in each slice have interrupts that occur depending on the selected mode. The individual parameter interrupts are indicated in the **PWMxGIR** register and enabled by the corresponding bits in the **PWMxGIE** register.

A timing example is shown in [Figure 29-2](#). Refer to the timing diagrams of each of the other modes for more details.

All the enabled PWMxGIR interrupts of one PWM instance are OR'd together into the PWMxIF bit in one of the PIR registers. The PWMxIF bit is read-only. When any of the PWMxGIR bits are set then the PWMxIF bit is true. All PWMxGIF flags must be reset to clear the PWMxIF bit. The PWMxIF interrupt is enabled with the PWMxIE bit in the corresponding PIE register.

29.8 Operation During Sleep

The PWM module operates in Sleep only if the PWM clock is Active. Some internal clock sources are automatically enabled to operate in Sleep when a peripheral using them is enabled. Those clock sources are identified in the clock source table shown in the PWMxCLK clock source selection register.

29.9 Register Definitions: PWM Control

Long bit name prefixes for the PWM peripherals are shown in the table below. Refer to the “**Long Bit Names**” section in the “**Register and Bit Naming Conventions**” chapter for more information.

Table 29-1. PWM Bit Name Prefixes

Peripheral	Bit Name Prefix
PWM1	PWM1
PWM2	PWM2

29.9.1 PWMxERS

Name: PWMxERS
Offset: 0x048C,0x050C

PWMx External Reset Source

Bit	7	6	5	4	3	2	1	0
					ERS[3:0]			
Access					R/W	R/W	R/W	R/W
Reset					0	0	0	0

Bits 3:0 – ERS[3:0] External Reset Source Select

ERS	Reset Source	
	PWM1	PWM2
1111–1110	Reserved (ERS Disabled)	
1101	CLC4_OUT	
1100	CLC3_OUT	
1011	CLC2_OUT	
1010	CLC1_OUT	
1001–0110	Reserved (ERS Disabled)	
0101	PWM2S1P2_OUT	Reserved (ERS Disabled)
0100	PWM2S1P1_OUT	Reserved (ERS Disabled)
0011	Reserved (ERS Disabled)	PWM1S1P2_OUT
0010	Reserved (ERS Disabled)	PWM1S1P1_OUT
0001	PWM1ERSPPS	PWM2ERSPPS
0000	ERS Disabled	

29.9.2 PWMxCLK

Name: PWMxCLK
Offset: 0x048D,0x050D

PWMx Clock Source

Bit	7	6	5	4	3	2	1	0
					CLK[3:0]			
Access					R/W	R/W	R/W	R/W
Reset					0	0	0	0

Bits 3:0 – CLK[3:0] PWM Clock Source Select

CLK	Source	Operates in Sleep
1111	Reserved	N/A
1110	CLC4_OUT	Yes ⁽¹⁾
1101	CLC3_OUT	Yes ⁽¹⁾
1100	CLC2_OUT	Yes ⁽¹⁾
1011	CLC1_OUT	Yes ⁽¹⁾
1010	NCO1_OUT	Yes ⁽¹⁾
1001	CLKR_OUT	Yes ⁽¹⁾
1000	EXTOSC	Yes
0111	SOSC	Yes
0110	MFINTOSC (32 kHz)	Yes
0101	MFINTOSC (500 kHz)	Yes
0100	LFINTOSC	Yes
0011	HFINTOSC	Yes
0010	F _{Osc}	No
0001	PWMIN1PPS	Yes ⁽¹⁾
0000	PWMIN0PPS	Yes ⁽¹⁾

Note: Operation during Sleep is possible if the clock supplying the source peripheral operates in Sleep.

29.9.3 PWMxLDS

Name: PWMxLDS
Offset: 0x048E,0x050E

PWMx Auto-load Trigger Source Select Register

Bit	7	6	5	4	3	2	1	0
						LDS[2:0]		
Access						R/W	R/W	R/W
Reset						0	0	0

Bits 2:0 – LDS[2:0] Auto-load Trigger Source Select

LDS	Source
111	Reserved
110	CLC4_OUT
101	CLC3_OUT
100	CLC2_OUT
011	CLC1_OUT
010	PWMIN1PPS
001	PWMIN0PPS
000	Auto-load Disabled

29.9.4 PWMxPR

Name: PWMxPR
Offset: 0x048F,0x050F

PWMx Period Register

Determines the PWMx period

Bit	15	14	13	12	11	10	9	8
	PR[15:8]							
Access	R/W	R/W	R/W	R/W	R/W	R/W	R/W	R/W
Reset	0	0	0	0	0	0	0	0
Bit	7	6	5	4	3	2	1	0
	PR[7:0]							
Access	R/W	R/W	R/W	R/W	R/W	R/W	R/W	R/W
Reset	0	0	0	0	0	0	0	0

Bits 15:0 – PR[15:0] PWM Period

Number of PWM clocks periods in the PWM period

Notes: The individual bytes in this multibyte register can be accessed with the following register names:

- PWMxPRH: Accesses the high byte PR[15:8]
- PWMxPRL: Accesses the low byte PR[7:0]

29.9.5 PWMxCPRE

Name: PWMxCPRE
Offset: 0x0491,0x0511

PWMx Clock Prescaler Register

Bit	7	6	5	4	3	2	1	0
	CPRE[7:0]							
Access	R/W	R/W	R/W	R/W	R/W	R/W	R/W	R/W
Reset	0	0	0	0	0	0	0	0

Bits 7:0 – CPRE[7:0] PWM Clock Prescale Value

Value	Description
n	PWM clock is prescaled by n+1

29.9.6 PWMxPIPOS

Name: PWMxPIPOS
Offset: 0x0492,0x0512

PWMx Period Interrupt Postscaler Register

Bit	7	6	5	4	3	2	1	0
	PIPOS[7:0]							
Access	R/W	R/W	R/W	R/W	R/W	R/W	R/W	R/W
Reset	0	0	0	0	0	0	0	0

Bits 7:0 – PIPOS[7:0] Period Interrupt Postscale Value

Value	Description
n	Period interrupt occurs after n+1 period events

29.9.7 PWMxGIR

Name: PWMxGIR
Offset: 0x0493,0x0513

PWMx Interrupt Register

Bit	7	6	5	4	3	2	1	0
							S1P2	S1P1
Access							R/W/HS	R/W/HS
Reset							0	0

Bit 1 – SaP2 Slice “a” Parameter 2 Interrupt Flag

Value	Mode	Description
1	Variable Aligned or Compare	Compare match between P2 and PWM counter has occurred
1	Center-Aligned	PWMx_SaP2_out has changed
1	Right Aligned	Left edge of PWMx_SaP2_out pulse has occurred
1	Left Aligned	Right edge of PWMx_SaP2_out pulse has occurred
0	All	Interrupt event has not occurred

Bit 0 – SaP1 Slice “a” Parameter 1 Interrupt Flag

Value	Mode	Description
1	Variable Aligned or Compare	Compare match between P1 and PWM counter has occurred
1	Center-Aligned	PWMx_SaP1_out has changed
1	Right Aligned	Left edge of PWMx_SaP1_out pulse has occurred
1	Left Aligned	Right edge of PWMx_SaP1_out pulse has occurred
0	All	Interrupt event has not occurred

29.9.8 PWMxGIE

Name: PWMxGIE
Offset: 0x0494,0x0514

PWMx Interrupt Enable Register

Bit	7	6	5	4	3	2	1	0
							S1P2	S1P1
Access							R/W	R/W
Reset							0	0

Bit 1 – SaP2 Slice “a” Parameter 2 Interrupt Enable

Value	Description
1	Slice “a” Parameter 2 match interrupt is enabled
0	Slice “a” Parameter 2 match interrupt is not enabled

Bit 0 – SaP1 Slice “a” Parameter 1 Interrupt Enable

Value	Description
1	Slice “a” Parameter 1 match interrupt is enabled
0	Slice “a” Parameter 1 match interrupt is not enabled

29.9.9 PWMxCON

Name: PWMxCON
Offset: 0x0495,0x0515

PWM Control Register

Bit	7	6	5	4	3	2	1	0
	EN					LD	ERSPOL	ERSNOW
Access	R/W					R/W/HC	R/W	R/W
Reset	0					0	0	0

Bit 7 – EN PWM Module Enable

Value	Description
1	PWM module is enabled.
0	PWM module is disabled. The prescaler, postscaler, and all internal logic is reset. Outputs go to their default states. Register values remain unchanged.

Bit 2 – LD Reload Registers

Reload the period and duty cycle registers on the next period event

Value	Description
1	Reload PR/P1/P2 registers
0	Reload not enabled or reload complete

Bit 1 – ERSPOL External Reset Polarity Select

Value	Description
1	External Reset input is active-low
0	External Reset input is active-high

Bit 0 – ERSNOW External Reset Mode Select

Determines when an external Reset event takes effect.

Value	Description
1	Stop counter on the next PWM clock. Output goes to the Inactive state.
0	Stop counter at the end of the period. Output goes to the Inactive state.

29.9.10 PWMxSaCFG

Name: PWMxSaCFG

PWM Slice “a” Configuration Register⁽¹⁾

Bit	7	6	5	4	3	2	1	0
	POL2	POL1			PPEN	MODE[2:0]		
Access	R/W	R/W			R/W	R/W	R/W	R/W
Reset	0	0			0	0	0	0

Bit 7 – POL2 PWM Slice “a” Parameter 2 Output Polarity

Value	Description
1	PWMx_SaP2_out is low true
0	PWMx_SaP2_out is high true

Bit 6 – POL1 PWM Slice “a” Parameter 1 Output Polarity

Value	Description
1	PWMx_SaP1_out is low true
0	PWMx_SaP1_out is high true

Bit 3 – PPEN Push-Pull Mode Enable

Each period the output alternates between PWMx_SaP1_out and PWMx_SaP2_out. Only Left and Right Aligned modes are supported. Other modes may exhibit unexpected results.

Value	Description
1	PWMx Slice “a” Push-Pull mode is enabled
0	PWMx Slice “a” Push-Pull mode is not enabled

Bits 2:0 – MODE[2:0] PWM Module Slice “a” Operating Mode Select

Selects operating mode for both PWMx_SaP1_out and PWMx_SaP2_out

Value	Description
11x	Reserved. Outputs go to Reset state.
101	Compare mode: Toggle PWMx_SaP1_out and PWMx_SaP2_out on PWM timer match with corresponding parameter register
100	Compare mode: Set PWMx_SaP1_out and PWMx_SaP2_out high on PWM timer match with corresponding parameter register
011	Variable Aligned mode
010	Center-Aligned mode
001	Right Aligned mode
000	Left Aligned mode

Note:

- Changes to this register must be done only when the EN bit is cleared.

29.9.11 PWMxSaP1

Name: PWMxSaP1

PWM Slice “a” Parameter 1 Register

Determines the active period of slice “a”, parameter 1 output

Bit	15	14	13	12	11	10	9	8
	P1[15:8]							
Access	R/W	R/W	R/W	R/W	R/W	R/W	R/W	R/W
Reset	0	0	0	0	0	0	0	0
Bit	7	6	5	4	3	2	1	0
	P1[7:0]							
Access	R/W	R/W	R/W	R/W	R/W	R/W	R/W	R/W
Reset	0	0	0	0	0	0	0	0

Bits 15:0 – P1[15:0] Parameter 1 Value

Value	Mode	Description
n	Compare	Compare match event occurs when PWMx timer = n (refer to MODE selections)
n	Variable Aligned	PWMx_SaP1_out and PWMx_SaP2 both go high when PWMx timer = n
n	Center-Aligned	PWMx_SaP1_out is high 2*n PWMx clock periods centered around PWMx period event
n	Right Aligned	PWMx_SaP1_out is high n PWMx clock periods at end of PWMx period
n	Left Aligned	PWMx_SaP1_out is high n PWMx clock periods at beginning of PWMx period

Notes: The individual bytes in this multibyte register can be accessed with the following register names:

- PWMxSaP1H: Accesses the high byte P1[15:8]
- PWMxSaP1L: Accesses the low byte P1[7:0]

29.9.12 PWMxSaP2

Name: PWMxSaP2

PWM Slice “a” Parameter 2 Register

Determines the active period of slice “a”, parameter 2 output

Bit	15	14	13	12	11	10	9	8
	P2[15:8]							
Access	R/W	R/W	R/W	R/W	R/W	R/W	R/W	R/W
Reset	0	0	0	0	0	0	0	0
Bit	7	6	5	4	3	2	1	0
	P2[7:0]							
Access	R/W	R/W	R/W	R/W	R/W	R/W	R/W	R/W
Reset	0	0	0	0	0	0	0	0

Bits 15:0 – P2[15:0] Parameter 2 Value

Value	Mode	Description
n	Compare	Compare match event occurs when PWMx timer = n (refer to MODE selections)
n	Variable Aligned	PWMx_SaP1_out and PWMx_SaP2 both go low when PWMx timer = n
n	Center-Aligned	PWMx_SaP2_out is high 2*n PWMx clock periods centered around PWMx period event
n	Right Aligned	PWMx_SaP2_out is high n PWMx clock periods at end of PWMx period
n	Left Aligned	PWMx_SaP2_out is high n PWMx clock periods at beginning of PWMx period

Notes: The individual bytes in this multibyte register can be accessed with the following register names:

- PWMxSaP2H: Accesses the high byte P2[15:8]
- PWMxSaP2L: Accesses the low byte P2[7:0]

29.9.13 PWMLOAD**Name:** PWMLOAD**Offset:** 0x049E

Mirror copies of all PWMxLD bits

Bit	7	6	5	4	3	2	1	0
							MPWM2LD	MPWM1LD
Access							R/W	R/W
Reset							0	0

Bits 0, 1 – MPWMxLD Mirror copy of PWMxLD bit

Mirror copies of all PWMxLD bits can be set simultaneously to synchronize the load event across all PWMs

Value	Description
1	PWMx parameter and period values will be transferred to their buffer registers at the next period Reset event
0	There are no PWMx period and parameter value transfers pending

29.9.14 PWMEN

Name: PWMEN
Offset: 0x049F

Mirror copies of all PWMxEN bits

Bit	7	6	5	4	3	2	1	0
							MPWM2EN	MPWM1EN
Access							R/W	R/W
Reset							0	0

Bits 0, 1 – MPWMxEN Mirror copy of PWMxEN bit

Mirror copies of all PWMxEN bits can be set simultaneously to synchronize the enable event across all PWMs

Value	Description
1	PWMx is enabled
0	PWMx is not enabled

29.10 Register Summary - PWM

Offset	Name	Bit Pos.	7	6	5	4	3	2	1	0
0x00	Reserved									
...										
0x048B										
0x048C	PWM1ERS	7:0						ERS[3:0]		
0x048D	PWM1CLK	7:0						CLK[3:0]		
0x048E	PWM1LDS	7:0						LDS[2:0]		
0x048F	PWM1PR	7:0	PR[7:0]							
		15:8	PR[15:8]							
0x0491	PWM1CPRE	7:0	CPRE[7:0]							
0x0492	PWM1PIPOS	7:0	PIPOS[7:0]							
0x0493	PWM1GIR	7:0							S1P2	S1P1
0x0494	PWM1GIE	7:0							S1P2	S1P1
0x0495	PWM1CON	7:0	EN					LD	ERSPOL	ERSNOW
0x0496	PWM1S1CFG	7:0	POL2	POL1			PPEN	MODE[2:0]		
0x0497	PWM1S1P1	7:0	P1[7:0]							
		15:8	P1[15:8]							
0x0499	PWM1S1P2	7:0	P2[7:0]							
		15:8	P2[15:8]							
0x049B	Reserved									
...										
0x049D										
0x049E	PWMLOAD	7:0							MPWM2LD	MPWM1LD
0x049F	PWMEN	7:0							MPWM2EN	MPWM1EN
0x04A0	Reserved									
...										
0x050B										
0x050C	PWM2ERS	7:0						ERS[3:0]		
0x050D	PWM2CLK	7:0						CLK[3:0]		
0x050E	PWM2LDS	7:0						LDS[2:0]		
0x050F	PWM2PR	7:0	PR[7:0]							
		15:8	PR[15:8]							
0x0511	PWM2CPRE	7:0	CPRE[7:0]							
0x0512	PWM2PIPOS	7:0	PIPOS[7:0]							
0x0513	PWM2GIR	7:0							S1P2	S1P1
0x0514	PWM2GIE	7:0							S1P2	S1P1
0x0515	PWM2CON	7:0	EN					LD	ERSPOL	ERSNOW
0x0516	PWM2S1CFG	7:0	POL2	POL1			PPEN	MODE[2:0]		
0x0517	PWM2S1P1	7:0	P1[7:0]							
		15:8	P1[15:8]							
0x0519	PWM2S1P2	7:0	P2[7:0]							
		15:8	P2[15:8]							

30. CLC - Configurable Logic Cell

The Configurable Logic Cell (CLC) module provides programmable logic that operates outside the speed limitations of software execution. The logic cell takes up to 256 input signals and, through the use of configurable gates, reduces those inputs to four logic lines that drive one of eight selectable single-output logic functions.

Input sources are a combination of the following:

- I/O pins
- Internal clocks
- Peripherals
- Register bits

The output can be directed internally to peripherals and to an output pin.

The following figure is a simplified diagram showing signal flow through the CLC. Possible configurations include:

- Combinatorial Logic
 - AND
 - NAND
 - AND-OR
 - AND-OR-INVERT
 - OR-XOR
 - OR-XNOR
- Latches
 - SR
 - Clocked D with Set and Reset
 - Transparent D with Set and Reset

Figure 30-1. CLC Simplified Block Diagram

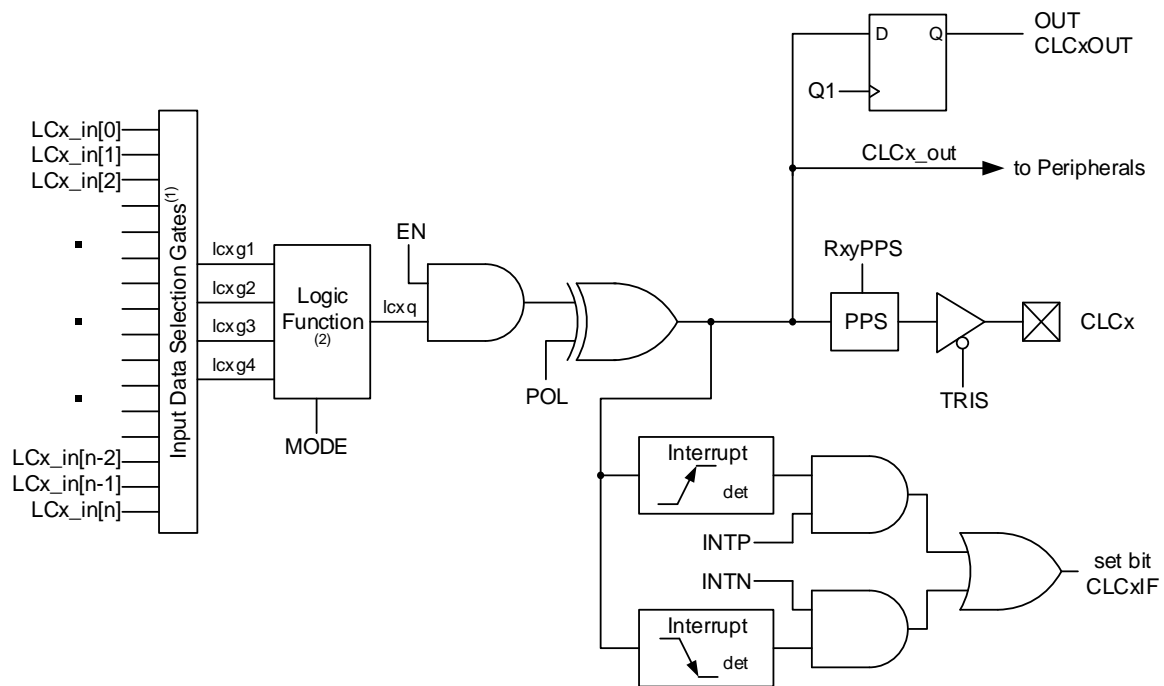

Notes:

1. See Figure 30-2 for input data selection and gating.
2. See Figure 30-3 for programmable logic functions.

30.1 CLC Setup

Programming the CLC module is performed by configuring the four stages in the logic signal flow. The four stages are:

- Data selection
- Data gating
- Logic function selection
- Output polarity

Each stage is set up at run time by writing to the corresponding CLC Special Function Registers. This has the added advantage of permitting logic reconfiguration on-the-fly during program execution.

30.1.1 Data Selection

Data inputs are selected with [CLCnSELO](#) through [CLCnSEL3](#) registers.



Important: Data selections are undefined at power-up.

Depending on the number of bits implemented in the [CLCnSELY](#) registers, there can be as many as 256 sources available as inputs to the configurable logic. Four multiplexers are used to

independently select these inputs to pass on to the next stage as indicated on the left side of the following diagram.

Data inputs in the figure are identified by a generic numbered input name.

Figure 30-2. Input Data Selection and Gating

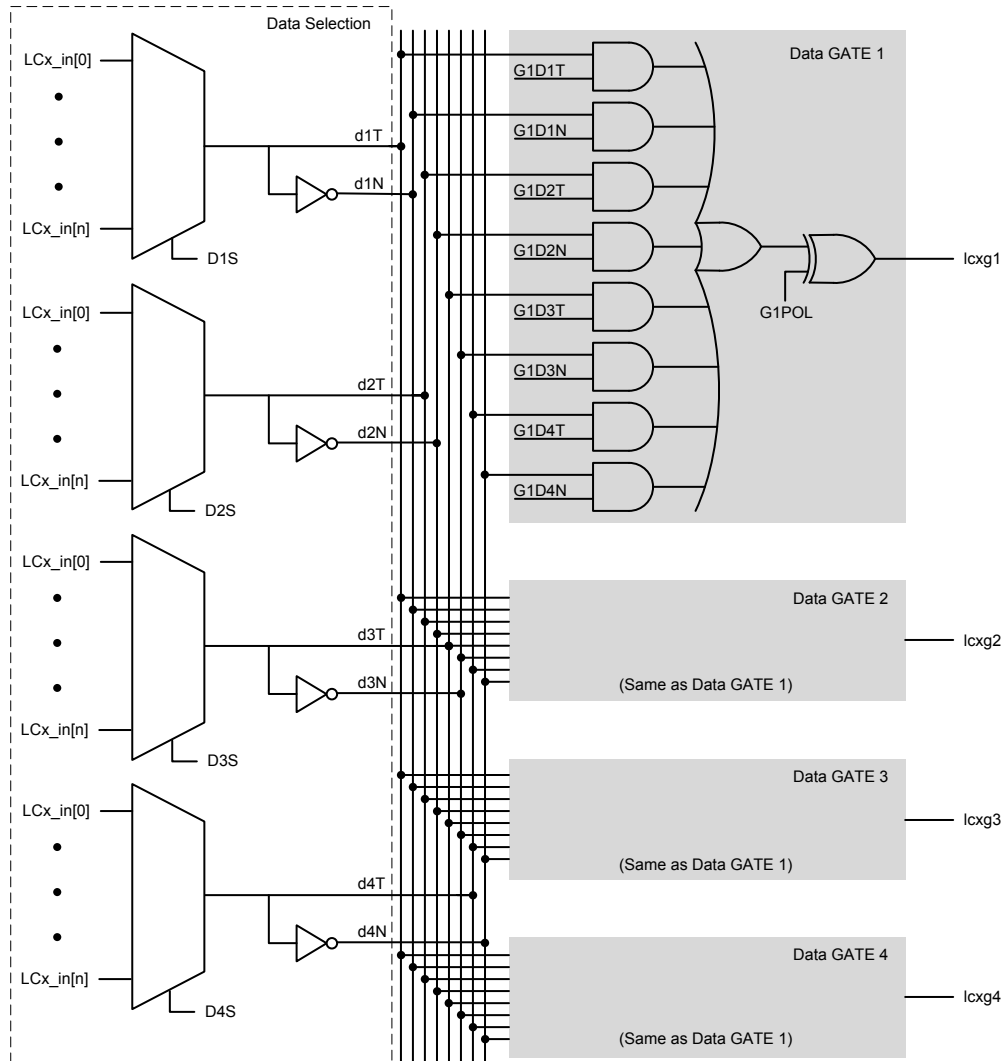

Note: All controls are undefined at power-up.

The [CLC Input Selection](#) table correlates the generic input name to the actual signal for each CLC module. The table column labeled 'DyS Value' indicates the MUX selection code for the selected data input. DyS is an abbreviation for the MUX select input codes, D1S through D4S, where 'y' is the gate number.

30.1.2 Data Gating

Outputs from the input multiplexers are directed to the desired logic function input through the data gating stage. Each data gate can direct any combination of the four selected inputs.

The gate stage is more than just signal direction. The gate can be configured to direct each input signal as inverted or noninverted data. Directed signals are ANDed together in each gate. The output of each gate can be inverted before going on to the logic function stage.

The gating is in essence a 1-to-4 input AND/NAND/OR/NOR gate. When every input is inverted and the output is inverted, the gate is an AND of all enabled data inputs. When the inputs and output are not inverted, the gate is an OR of all enabled inputs.

Table 30-1 summarizes the basic logic that can be obtained in gate 1 by using the gate logic select bits. The table shows the logic of four input variables, but each gate can be configured to use less than four. If no inputs are selected, the output will be '0' or '1', depending on the gate output polarity bit.

Table 30-1. Data Gating Logic

CLCnGLSy	GyPOL	Gate Logic
0x55	1	AND
0x55	0	NAND
0xAA	1	NOR
0xAA	0	OR
0x00	0	Logic '0'
0x00	1	Logic '1'

It is possible (but not recommended) to select both the true and negated values of an input. When this is done, the gate output is '0', regardless of the other inputs, but may emit logic glitches (transient-induced pulses). If the output of the channel must be '0' or '1', the recommended method is to set all gate bits to '0' and use the gate polarity bit to set the desired level.

Data gating is configured with the logic gate select registers as follows:

- Gate 1: [CLCnGLS0](#)
- Gate 2: [CLCnGLS1](#)
- Gate 3: [CLCnGLS2](#)
- Gate 4: [CLCnGLS3](#)

Note: Register number suffixes are different than the gate numbers because other variations of this module have multiple gate selections in the same register.

Data gating is indicated in the right side of [Figure 30-2](#). Only one gate is shown in detail. The remaining three gates are configured identically, except when the data enables correspond to the enables for that gate.

30.1.3 Logic Function

There are eight available logic functions including:

- AND-OR
- OR-XOR
- AND
- SR Latch
- D Flip-Flop with Set and Reset
- D Flip-Flop with Reset
- J-K Flip-Flop with Reset
- Transparent Latch with Set and Reset

Logic functions are shown in the following diagram. Each logic function has four inputs and one output. The four inputs are the four data gate outputs of the previous stage. The output is fed to the inversion stage and, from there, to other peripherals, an output pin, and back to the CLC itself.

Figure 30-3. Programmable Logic Functions

Rev: 10-000122B
9/13/2016

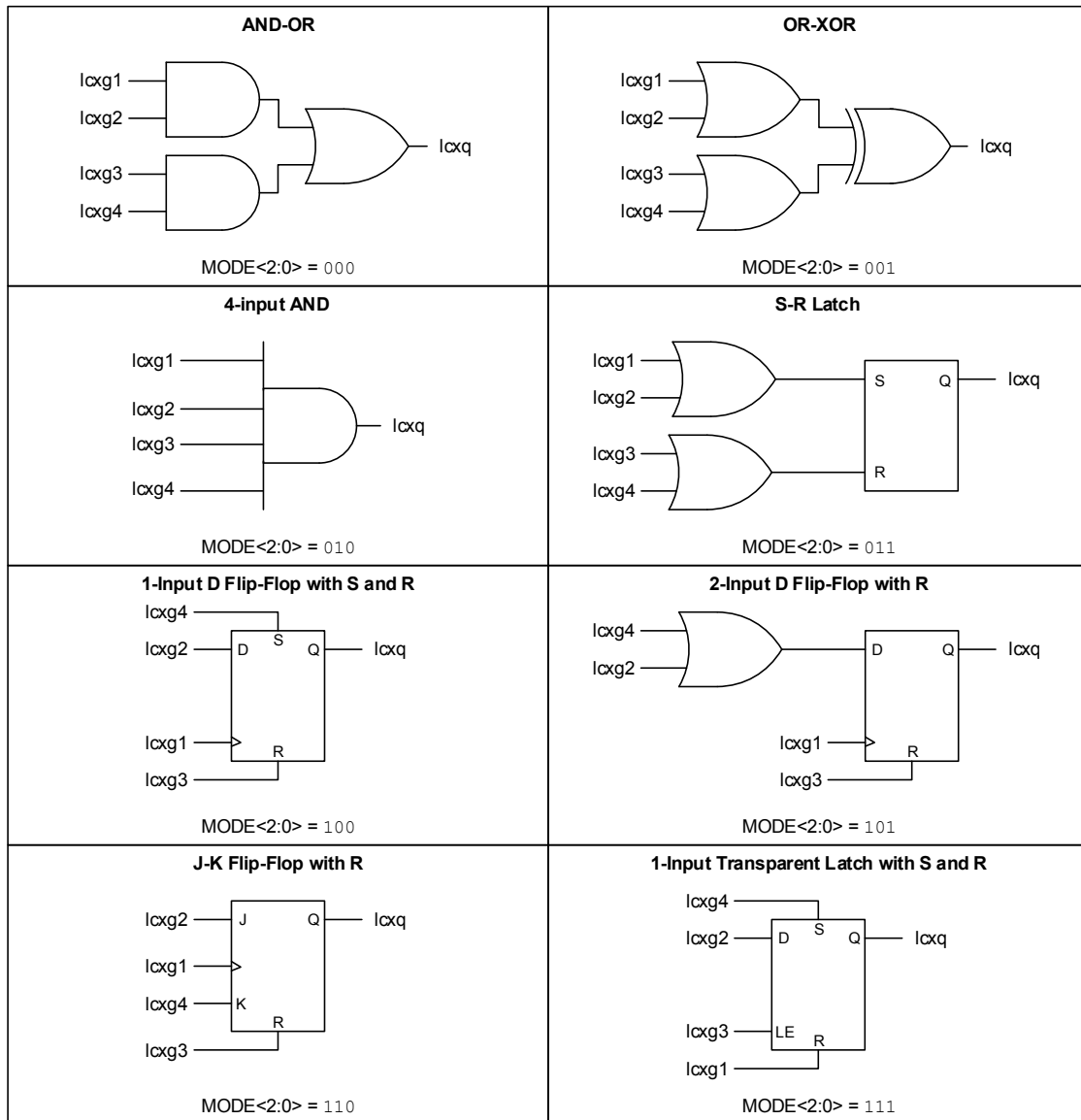

30.1.4 Output Polarity

The last stage in the Configurable Logic Cell is the output polarity. Setting the **POL** bit inverts the output signal from the logic stage. Changing the polarity while the interrupts are enabled will cause an interrupt for the resulting output transition.

30.2 CLC Interrupts

An interrupt will be generated upon a change in the output value of the CLCx when the appropriate interrupt enables are set. A rising edge detector and a falling edge detector are present in each CLC for this purpose.

The CLCxIF bit of the associated PIR register will be set when either edge detector is triggered and its associated enable bit is set. The **INTP** bit enables rising edge interrupts and the **INTN** bit enables falling edge interrupts.

To fully enable the interrupt, set the following bits:

- The CLCxIE bit of the respective PIE register
- The **INTP** bit (for a rising edge detection)
- The **INTN** bit (for a falling edge detection)

The CLCxIF bit of the respective PIR register must be cleared in software as part of the interrupt service. If another edge is detected while this flag is being cleared, the flag will still be set at the end of the sequence.

30.3 Effects of a Reset

The CLCnCON register is cleared to '0' as the result of a Reset. All other selection and gating values remain unchanged.

30.4 Output Mirror Copies

Mirror copies of all CLCxOUT bits are contained in the **CLCDATA** register. Reading this register reads the outputs of all CLCs simultaneously. This prevents any reading skew introduced by testing or reading the OUT bits in the individual CLCnCON registers.

30.5 Operation During Sleep

The CLC module operates independently from the system clock and will continue to run during Sleep, provided that the input sources selected remain Active.

The HFINTOSC remains Active during Sleep when the CLC module is enabled and the HFINTOSC is selected as an input source, regardless of the system clock source selected.

In other words, if the HFINTOSC is simultaneously selected as both the system clock and as a CLC input source then, when the CLC is enabled, the CPU will go Idle during Sleep, but the CLC will continue to operate and the HFINTOSC will remain Active. This will have a direct effect on the Sleep mode current.

30.6 CLC Setup Steps

These steps need to be followed when setting up the CLC:

1. Disable the CLC by clearing the **EN** bit.
2. Select the desired inputs using the **CLCnSELO** through **CLCnSEL3** registers.
3. Clear any ANSEL bits associated with CLC input pins.
4. Set all TRIS bits associated with inputs. However, a CLC input will also operate if the pin is configured as an output, in which case the TRIS bits must be cleared.
5. Enable the chosen inputs through the four gates using the **CLCnGLS0** through **CLCnGLS3** registers.
6. Select the gate output polarities with the **GyPOL** bits.
7. Select the desired logic function with the **MODE** bits.
8. Select the desired polarity of the logic output with the **POL** bit (this step may be combined with the previous gate output polarity step).
9. If driving a device pin, configure the associated pin PPS control register and also clear the TRIS bit corresponding to that output.
10. Configure the interrupts (optional). See the **CLC Interrupts** section.
11. Enable the CLC by setting the **EN** bit.

30.7 Register Overlay

All CLCs in this device share the same set of registers. Only one CLC instance is accessible at a time. The value in the **CLCSELECT** register is one less than the selected CLC instance. For example, a CLCSELECT value of '0' selects CLC1.

30.8 Register Definitions: Configurable Logic Cell

30.8.1 CLCSELECT

Name: CLCSELECT
Offset: 0x0696

CLC Instance Selection Register

Selects which CLC instance is accessed by the CLC registers

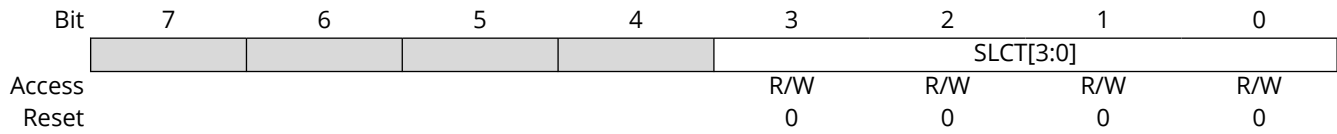

Bits 3:0 – SLCT[3:0] CLC instance selection

Value	Description
n	Shared CLC registers of instance n+1 are selected for read and write operations

30.8.2 CLCnCON

Name: CLCnCON
Offset: 0x068C

Configurable Logic Cell Control Register

Bit	7	6	5	4	3	2	1	0
	EN		OUT	INTP	INTN	MODE[2:0]		
Access	R/W		R	R/W	R/W	R/W	R/W	R/W
Reset	0		0	0	0	0	0	0

Bit 7 – EN CLC Enable

Value	Description
1	Configurable logic cell is enabled and mixing signals
0	Configurable logic cell is disabled and has logic zero output

Bit 5 – OUT Logic cell output data, after LCPOL. Sampled from CLCxOUT.

Bit 4 – INTP Configurable Logic Cell Positive Edge Going Interrupt Enable

Value	Description
1	CLCxIF will be set when a rising edge occurs on CLCxOUT
0	Rising edges on CLCxOUT have no effect on CLCxIF

Bit 3 – INTN Configurable Logic Cell Negative Edge Going Interrupt Enable

Value	Description
1	CLCxIF will be set when a falling edge occurs on CLCxOUT
0	Falling edges on CLCxOUT have no effect on CLCxIF

Bits 2:0 – MODE[2:0] Configurable Logic Cell Functional Mode Selection

Value	Description
111	Cell is 1-input transparent latch with Set and Reset
110	Cell is J-K flip-flop with Reset
101	Cell is 2-input D flip-flop with Reset
100	Cell is 1-input D flip-flop with Set and Reset
011	Cell is SR latch
010	Cell is 4-input AND
001	Cell is OR-XOR
000	Cell is AND-OR

30.8.3 CLCnPOL

Name: CLCnPOL
Offset: 0x068D

Signal Polarity Control Register

Bit	7	6	5	4	3	2	1	0
	POL				G4POL	G3POL	G2POL	G1POL
Access	R/W				R/W	R/W	R/W	R/W
Reset	0				x	x	x	x

Bit 7 – POL CLCxOUT Output Polarity Control

Value	Description
1	The output of the logic cell is inverted
0	The output of the logic cell is not inverted

Bits 0, 1, 2, 3 – GyPOL Gate Output Polarity Control

Reset States: POR/BOR = xxxx

All Other Resets = uuuu

Value	Description
1	The gate output is inverted when applied to the logic cell
0	The output of the gate is not inverted

30.8.4 CLCnSELO

Name: CLCnSELO
Offset: 0x068E

Generic CLCn Data 1 Select Register

Bit	7	6	5	4	3	2	1	0
	D1S[6:0]							
Access		R/W	R/W	R/W	R/W	R/W	R/W	R/W
Reset		x	x	x	x	x	x	x

Bits 6:0 – D1S[6:0] CLCn Data1 Input Selection

Table 30-2. CLC Input Selection

DyS	Input Source	DyS (cont.)	Input Source (cont.)
[0] 0000 0000	CLCIN0PPS	[32] 0010 0000	C2_OUT
[1] 0000 0001	CLCIN1PPS	[33] 0010 0001	ZCD_OUT
[2] 0000 0010	CLCIN2PPS	[34] 0010 0010	IOCIF
[3] 0000 0011	CLCIN3PPS	[35] 0010 0011	CLC1_OUT
[4] 0000 0100	F _{Osc}	[36] 0010 0100	CLC2_OUT
[5] 0000 0101	HFINTOSC	[37] 0010 0101	CLC3_OUT
[6] 0000 0110	LFINTOSC	[38] 0010 0110	CLC4_OUT
[7] 0000 0111	MFINTOSC (500 kHz)	[39] 0010 0111	TX1/CK1
[8] 0000 1000	MFINTOSC (32 kHz)	[40] 0010 1000	TX2/CK2
[9] 0000 1001	—	[41] 0010 1001	SDA1/SDO1
[10] 0000 1010	SOSC	[42] 0010 1010	SCL1/SCK1
[11] 0000 1011	EXTOSC	[43] 0010 1011	SDA2/SDO2
[12] 0000 1100	ADCRC	[44] 0010 1100	SCL2/SCK2
[13] 0000 1101	CLKR_OUT	[45] 0010 1101	CWG1A_OUT
[14] 0000 1110	TMR0_Overflow	[46] 0010 1110	CWG1B_OUT
[15] 0000 1111	TMR1_Overflow	...	—
[16] 0001 0000	TMR2_Postscaled_OUT	...	—
[17] 0001 0001	TMR3_Overflow	...	—
[18] 0001 0010	TMR4_Postscaled_OUT	...	—
[19] 0001 0011	—	...	—
[20] 0001 0100	CCP1_OUT	...	—
[21] 0001 0101	CCP2_OUT	...	—
[22] 0001 0110	PWM1S1P1_OUT	...	—
[23] 0001 0111	PWM1S1P2_OUT	...	—
[24] 0001 1000	PWM2S1P1_OUT	...	—
[25] 0001 1001	PWM2S1P2_OUT	...	—
[26] 0001 1010	—	...	—
[27] 0001 1011	—	...	—
[28] 0001 1100	—	...	—
[29] 0001 1101	—	...	—
[30] 0001 1110	NCO1_OUT	...	—
[31] 0001 1111	C1_OUT	[127] 0111 1111	—

Reset States: POR/BOR = xxxxxxxx
All Other Resets = uuuuuuuu

30.8.5 CLCnSEL1

Name: CLCnSEL1
Offset: 0x068F

Generic CLCn Data 1 Select Register

Bit	7	6	5	4	3	2	1	0
		D2S[6:0]						
Access		R/W	R/W	R/W	R/W	R/W	R/W	R/W
Reset		x	x	x	x	x	x	x

Bits 6:0 – D2S[6:0] CLCn Data2 Input Selection

Reset States: POR/BOR = xxxxxxx

All Other Resets = uuuuuuu

Value	Description
n	Refer to the CLC Input Selection table for input selections

30.8.6 CLCnSEL2

Name: CLCnSEL2
Offset: 0x0690

Generic CLCn Data 1 Select Register

Bit	7	6	5	4	3	2	1	0
		D3S[6:0]						
Access		R/W	R/W	R/W	R/W	R/W	R/W	R/W
Reset		x	x	x	x	x	x	x

Bits 6:0 – D3S[6:0] CLCn Data3 Input Selection

Reset States: POR/BOR = xxxxxxx

All Other Resets = uuuuuuu

Value	Description
n	Refer to the CLC Input Selection table for input selections

30.8.7 CLCnSEL3

Name: CLCnSEL3
Offset: 0x0691

Generic CLCn Data 4 Select Register

Bit	7	6	5	4	3	2	1	0
		D4S[6:0]						
Access		R/W	R/W	R/W	R/W	R/W	R/W	R/W
Reset		x	x	x	x	x	x	x

Bits 6:0 – D4S[6:0] CLCn Data4 Input Selection

Reset States: POR/BOR = xxxxxxxx

All Other Resets = uuuuuuuu

Value	Description
n	Refer to the CLC Input Selection table for input selections

30.8.8 CLCnGLS0

Name: CLCnGLS0
Offset: 0x0692

CLCn Gate1 Logic Select Register

Bit	7	6	5	4	3	2	1	0
	G1D4T	G1D4N	G1D3T	G1D3N	G1D2T	G1D2N	G1D1T	G1D1N
Access	R/W	R/W	R/W	R/W	R/W	R/W	R/W	R/W
Reset	x	x	x	x	x	x	x	x

Bits 1, 3, 5, 7 – G1DyT dyT: Gate1 Data 'y' True (noninverted)

Reset States: POR/BOR = xxxx

All Other Resets = uuuu

Value	Description
1	dyT is gated into g1
0	dyT is not gated into g1

Bits 0, 2, 4, 6 – G1DyN dyN: Gate1 Data 'y' Negated (inverted)

Reset States: POR/BOR = xxxx

All Other Resets = uuuu

Value	Description
1	dyN is gated into g1
0	dyN is not gated into g1

30.8.9 CLCnGLS1

Name: CLCnGLS1
Offset: 0x0693

CLCn Gate2 Logic Select Register

Bit	7	6	5	4	3	2	1	0
	G2D4T	G2D4N	G2D3T	G2D3N	G2D2T	G2D2N	G2D1T	G2D1N
Access	R/W	R/W	R/W	R/W	R/W	R/W	R/W	R/W
Reset	x	x	x	x	x	x	x	x

Bits 1, 3, 5, 7 – G2DyT dyT: Gate2 Data 'y' True (noninverted)

Reset States: POR/BOR = xxxx

All Other Resets = uuuu

Value	Description
1	dyT is gated into g2
0	dyT is not gated into g2

Bits 0, 2, 4, 6 – G2DyN dyN: Gate2 Data 'y' Negated (inverted)

Reset States: POR/BOR = xxxx

All Other Resets = uuuu

Value	Description
1	dyN is gated into g2
0	dyN is not gated into g2

30.8.10 CLCnGLS2

Name: CLCnGLS2
Offset: 0x0694

CLCn Gate3 Logic Select Register

Bit	7	6	5	4	3	2	1	0
	G3D4T	G3D4N	G3D3T	G3D3N	G3D2T	G3D2N	G3D1T	G3D1N
Access	R/W	R/W	R/W	R/W	R/W	R/W	R/W	R/W
Reset	x	x	x	x	x	x	x	x

Bits 1, 3, 5, 7 – G3DyT dyT: Gate3 Data 'y' True (noninverted)

Reset States: POR/BOR = xxxx

All Other Resets = uuuu

Value	Description
1	dyT is gated into g3
0	dyT is not gated into g3

Bits 0, 2, 4, 6 – G3DyN dyN: Gate3 Data 'y' Negated (inverted)

Reset States: POR/BOR = xxxx

All Other Resets = uuuu

Value	Description
1	dyN is gated into g3
0	dyN is not gated into g3

30.8.11 CLCnGLS3

Name: CLCnGLS3
Offset: 0x0695

CLCn Gate4 Logic Select Register

Bit	7	6	5	4	3	2	1	0
	G4D4T	G4D4N	G4D3T	G4D3N	G4D2T	G4D2N	G4D1T	G4D1N
Access	R/W	R/W	R/W	R/W	R/W	R/W	R/W	R/W
Reset	x	x	x	x	x	x	x	x

Bits 1, 3, 5, 7 – G4DyT dyT: Gate4 Data 'y' True (noninverted)

Reset States: POR/BOR = xxxx

All Other Resets = uuuu

Value	Description
1	dyT is gated into g4
0	dyT is not gated into g4

Bits 0, 2, 4, 6 – G4DyN dyN: Gate4 Data 'y' Negated (inverted)

Reset States: POR/BOR = xxxx

All Other Resets = uuuu

Value	Description
1	dyN is gated into g4
0	dyN is not gated into g4

30.8.12 CLCDATA

Name: CLCDATA
Offset: 0x0697

CLC Data Output Register

Mirror copy of CLC outputs

Bit	7	6	5	4	3	2	1	0
					CLC4OUT	CLC3OUT	CLC2OUT	CLC1OUT
Access					R/W	R/W	R/W	R/W
Reset					0	0	0	0

Bits 0, 1, 2, 3 - CLCxOUT Mirror copy of CLCx_out

Value	Description
1	CLCx_out is 1
0	CLCx_out is 0

30.9 Register Summary - CLC Control

Offset	Name	Bit Pos.	7	6	5	4	3	2	1	0
0x00 ...	Reserved									
0x068B										
0x068C	CLCnCON	7:0	EN		OUT	INTP	INTN	MODE[2:0]		
0x068D	CLCnPOL	7:0	POL				G4POL	G3POL	G2POL	G1POL
0x068E	CLCnSEL0	7:0					D1S[6:0]			
0x068F	CLCnSEL1	7:0					D2S[6:0]			
0x0690	CLCnSEL2	7:0					D3S[6:0]			
0x0691	CLCnSEL3	7:0					D4S[6:0]			
0x0692	CLCnGLS0	7:0	G1D4T	G1D4N	G1D3T	G1D3N	G1D2T	G1D2N	G1D1T	G1D1N
0x0693	CLCnGLS1	7:0	G2D4T	G2D4N	G2D3T	G2D3N	G2D2T	G2D2N	G2D1T	G2D1N
0x0694	CLCnGLS2	7:0	G3D4T	G3D4N	G3D3T	G3D3N	G3D2T	G3D2N	G3D1T	G3D1N
0x0695	CLCnGLS3	7:0	G4D4T	G4D4N	G4D3T	G4D3N	G4D2T	G4D2N	G4D1T	G4D1N
0x0696	CLCSELECT	7:0					SLCT[3:0]			
0x0697	CLCDATA	7:0					CLC4OUT	CLC3OUT	CLC2OUT	CLC1OUT

31. MSSP - Host Synchronous Serial Port Module

The Host Synchronous Serial Port (MSSP) module is a serial interface useful for communicating with other peripheral or microcontroller devices. These peripheral devices may be serial EEPROMs, shift registers, display drivers, A/D converters, etc. The MSSP module can operate in one of two modes:

- Serial Peripheral Interface (SPI)
- Inter-Integrated Circuit (I²C)

The SPI interface can operate in Host or Client mode and supports the following features:

- Selectable clock parity
- Client select synchronization (Client mode only)
- Daisy-chain connection of client devices

The I²C interface can operate in Host or Client mode and supports the following modes and features:

- Byte NACKing (Client mode)
- Limited multi-host support
- 7-bit and 10-bit addressing
- Start and stop interrupts
- Interrupt masking
- Clock stretching
- Bus collision detection
- General call address matching
- Address masking
- Address Hold and Data Hold modes
- Selectable SDA hold times

31.1 SPI Mode Overview

The Serial Peripheral Interface (SPI) is a synchronous serial data communication bus that operates in Full Duplex mode. Devices communicate in a host/client environment where the host device initiates the communication. A client device is selected for communication using the Client Select feature.

The SPI bus specifies four signal connections:

- Serial Clock (SCK)
- Serial Data Out (SDO)
- Serial Data In (SDI)
- Client Select (\overline{SS})

Figure 31-1 shows the block diagram of the MSSP module when operating in SPI mode.

Figure 31-1. MSSP Block Diagram (SPI Mode)

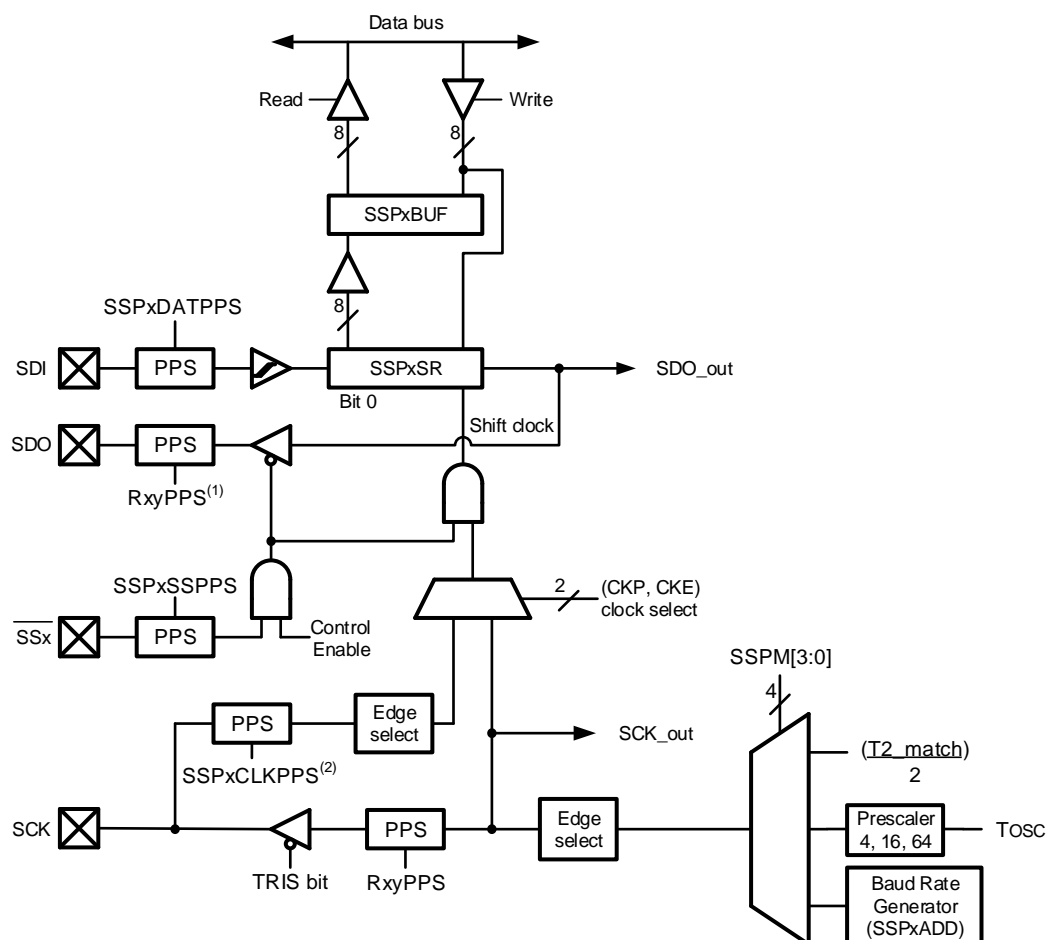

- Notes:** 1. Output selection for Host mode.
2. Input selection for Client and Host modes.

The SPI bus operates with a single host device and one or more client devices. When multiple client devices are used, an independent Client Select connection is required from the host device to each client device. The host selects only one client at a time. Most client devices have tri-state outputs, so their output signal appears disconnected from the bus when they are not selected.

Figure 31-2 shows a typical connection between a host device and multiple client devices.

Figure 31-2. SPI Host and Multiple Client Connection

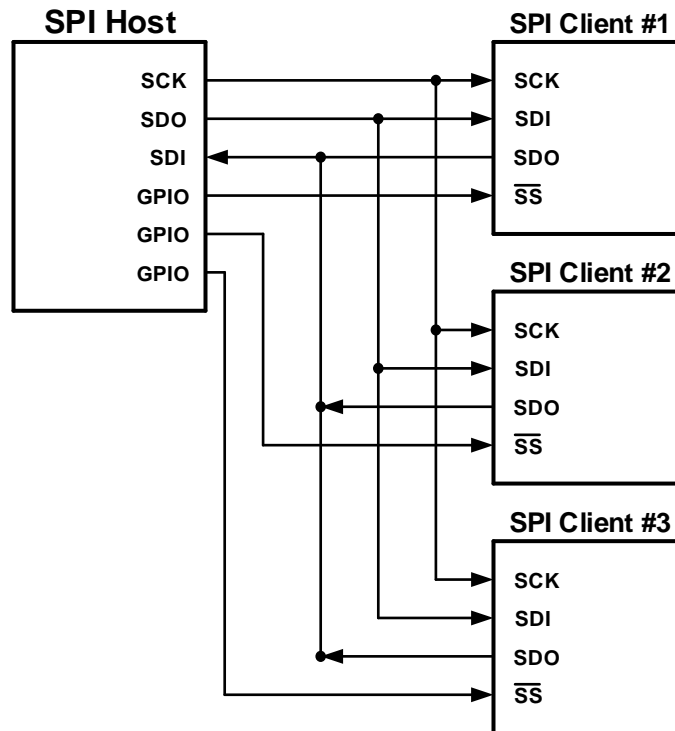

Transmissions involve two shift registers, eight bits in size: One in the host and one in the client. Data are shifted out one bit at a time, with the Most Significant bit (MSb) shifted out first. At the same time, a new Least Significant bit (LSb) is shifted into the same register.

Figure 31-3 shows a typical connection between two processors configured as host and client devices.

Figure 31-3. SPI Host/Client Connection

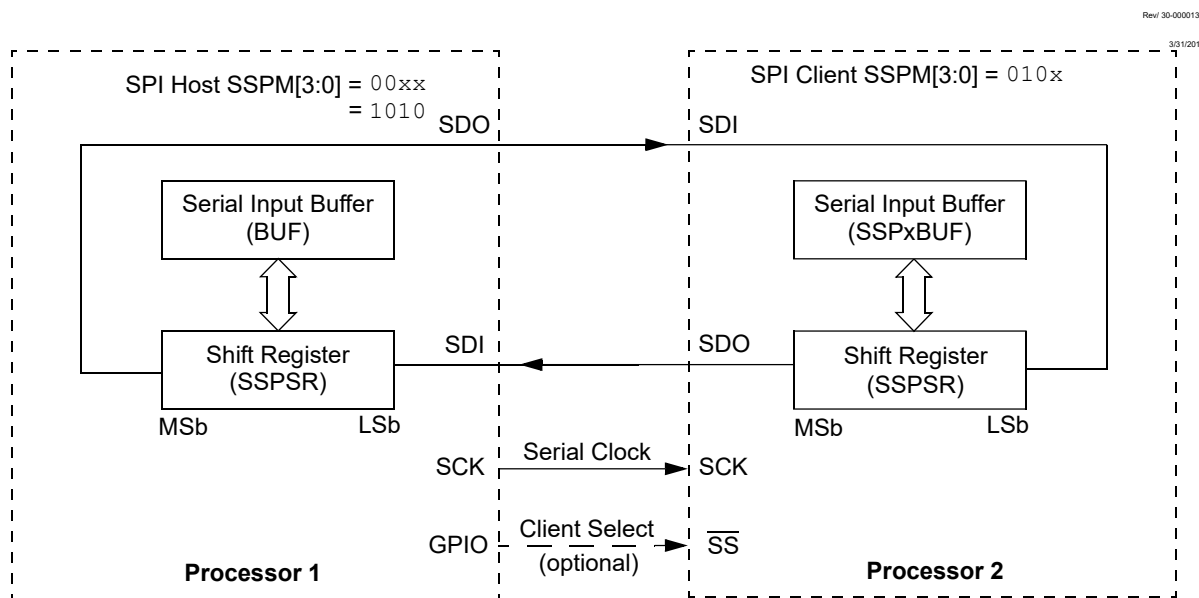

Data are shifted out of both shift registers on the programmed clock edge and are latched on the opposite edge of the clock.

The host device transmits information out on its SDO output pin, which is connected to and received by the client's SDI input pin. The client device transmits information out on its SDO output pin, which is connected to and received by the host's SDI input pin.

To begin communication, the host device transmits both the MSb from its shift register and the clock signal. Both the host and client devices need to be configured for the same clock polarity. During each SPI clock cycle, a full-duplex data transmission occurs. This means that while the host device is sending out the MSb from its shift register (on its SDO pin) and the client device is reading this bit and saving it as the LSb of its shift register, the client device is also sending out the MSb from its shift register (on its SDO pin) and the host device is reading this bit and saving it as the LSb of its shift register.

After eight bits have been shifted out, the host and client have exchanged register values. If there is more data to exchange, the shift registers are loaded with new data and the process repeats itself.

Whether the data are meaningful or not (dummy data) depends on the application software. This leads to three scenarios for data transmission:

- Host sends useful data and client sends dummy data.
- Host sends useful data and client sends useful data.
- Host sends dummy data and client sends useful data.

Transmissions must be performed in multiples of eight clock cycles. When there is no more data to be transmitted, the host stops sending the clock signal and it deselects the client.

Every client device connected to the bus that has not been selected through its Client Select line must disregard the clock and transmission signals and must not transmit out any data of its own.

31.1.1 SPI Mode Registers

The MSSP module has six registers for SPI mode operation. They are:

- MSSP Status Register ([SSPxSTAT](#))

- MSSP Control Register 1 ([SSPxCON1](#))
- MSSP Control Register 3 ([SSPxCON3](#))
- MSSP Data Buffer Register ([SSPxBUF](#))
- MSSP Address Register ([SSPxADD](#))
- MSSP Shift (SSPSR) register (not directly accessible)

SSPxCON1 and SSPxSTAT are the control and status registers for SPI mode operation. The SSPxCON1 register is readable and writable. The lower six bits of the SSPxSTAT are read-only. The upper two bits of the SSPxSTAT are read/write.

One of the five SPI Host modes uses the SSPxADD value to determine the Baud Rate Generator clock frequency. More information on the Baud Rate Generator is available in [31.3. Baud Rate Generator](#).

SSPSR is the shift register used for shifting data in and out. SSPxBUF provides indirect access to the SSPSR register. SSPxBUF is the buffer register to which data bytes are written and from which data bytes are read.

In receive operations, SSPSR and SSPxBUF together create a buffered receiver. When SSPSR receives a complete byte, it is transferred to SSPxBUF and the SSPxIF interrupt is set.

During transmission, the SSPxBUF is not buffered. A write to SSPxBUF will write to both SSPxBUF and SSPSR.

31.1.2 SPI Mode Operation

When initializing the SPI, several options need to be specified. This is done by programming the appropriate control bits ([SSPxCON1](#)[5:0] and [SSPxSTAT](#)[7:6]). These control bits allow the following to be specified:

- Host mode (SCK is the clock output)
- Client mode (SCK is the clock input)
- Clock Polarity (Idle state of SCK)
- Data Input Sample Phase (middle or end of data output time)
- Clock Edge (output data on rising/falling edge of SCK)
- Clock Rate (Host mode only)
- Client Select mode (Client mode only)

To enable the serial port, the SSP Enable ([SSPEN](#)) bit must be set. To reset or reconfigure SPI mode, clear the SSPEN bit, re-initialize the SSPxCONy registers and then set the SSPEN bit. The SDI, SDO, SCK and \overline{SS} serial port pins are selected with the PPS controls. For the pins to behave as the serial port function, some must have their data direction bits (in the TRIS register) appropriately programmed as follows:

- SDI must have the corresponding TRIS bit set
- SDO must have the corresponding TRIS bit cleared
- SCK (Host mode) must have the corresponding TRIS bit cleared
- SCK (Client mode) must have the corresponding TRIS bit set
- The RxyPPS and SSPxCLKPPS controls must select the same pin
- \overline{SS} must have the corresponding TRIS bit set

Any serial port function that is not desired may be overridden by programming the corresponding data direction (TRIS) register to the opposite value.

The MSSP consists of a Transmit/Receive Shift Register (SSPSR) and a buffer register ([SSPxBUF](#)). The SSPSR shifts the data in and out of the device, MSb first. The SSPxBUF holds the data that

were written to the SSPSR until the received data are ready. Once the eight bits of data have been received, that byte is moved to the SSPxBUF register. Then, the Buffer Full Status (BF) bit and the MSSP Interrupt Flag (SSPxIF) bit are set. This double-buffering of the received data allows the next byte to start reception before reading the data that was just received. Any write to the SSPxBUF register during transmission/reception of data will be ignored and the Write Collision Detect (WCOL) bit will be set. User software must clear the WCOL bit to allow the following write(s) to the SSPxBUF register to complete successfully.

When the application software is expecting to receive valid data, the SSPxBUF must be read before the next byte of data to be transferred is written to the SSPxBUF. The BF bit indicates when SSPxBUF has been loaded with the received data (transmission is complete). When the SSPxBUF is read, the BF bit is cleared. This data may be irrelevant if the SPI is only a transmitter. The MSSP interrupt is used to determine when the transmission/reception has completed. If the interrupt method is not going to be used, then software polling can be done to ensure that a write collision does not occur.



Important: The SSPSR is not directly readable or writable and can only be accessed by addressing the SSPxBUF register.

31.1.2.1 SPI Host Mode

The Host can initiate the data transfer at any time because it controls the SCK line. The Host determines when the client (Processor 2, [Figure 31-3](#)) is to broadcast data by the software protocol.

In Host mode, the data are transmitted/received as soon as the SSPxBUF register is written to. If the SPI is only going to receive, the SDO output may be disabled (programmed as an input). The SSPSR register will continue to shift in the signal present on the SDI pin at the programmed clock rate. As each byte is received, it will be loaded into the SSPxBUF register (interrupts and Status bits appropriately set).

The clock polarity is selected by appropriately programming the Clock Polarity Select (CKP) and SPI Clock Edge Select (CKE) bits. [Figure 31-4](#) shows the four clocking configurations. When the CKE bit is set, the SDO data are valid one half of a clock cycle before a clock edge appears on SCK, and transmission occurs on the transition from the Active to Idle clock state. When CKE is clear, the SDO data are valid at the same time as the clock edge appears on SCK, and transmission occurs on the transition from the Idle to Active clock states.

The SPI Data Input Sample (SMP) bit determines when the SDI input is sampled. When SMP is set, input data are sampled at the end of the data output time. When SMP is clear, input data are sampled at the middle of the data output time.

The SPI clock rate (bit rate) is user-programmable to be one of the following:

- $F_{OSC}/4$ (or T_{CY})
- $F_{OSC}/16$ (or $4 * T_{CY}$)
- $F_{OSC}/64$ (or $16 * T_{CY}$)
- Timer2 output/2
- $F_{OSC}/(4 * (SSPxADD + 1))$



Important: In Host mode, the clock signal output to the SCK pin is also the clock signal input to the peripheral. The pin selected for output with the RxyPPS register must also be selected as the peripheral input with the SSPxCLKPPS register.

Figure 31-4. SPI Mode Waveform (Host Mode)

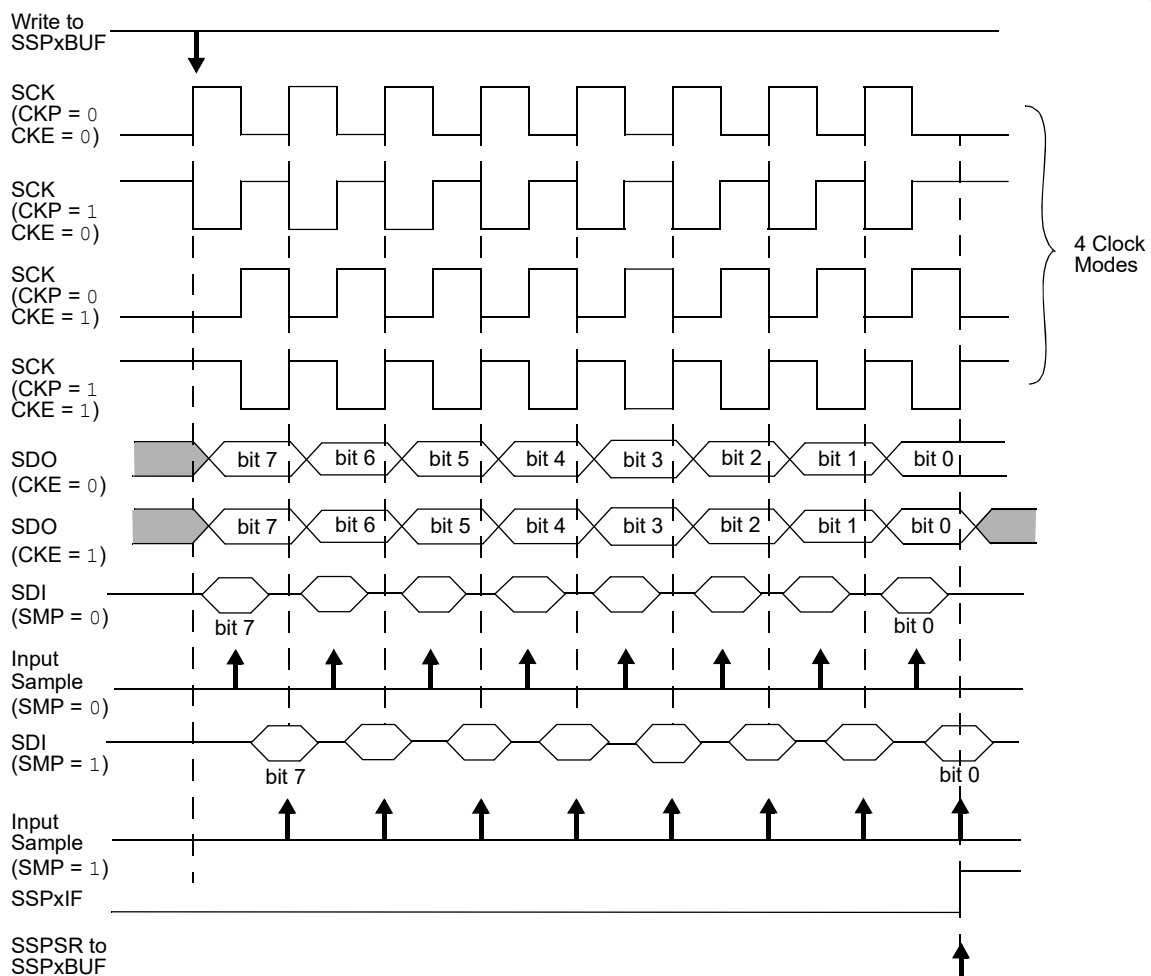

31.1.2.2 SPI Client Mode

In Client mode, the data are transmitted and received as external clock pulses appear on SCK. When the last bit is latched, the SSPxIF Interrupt Flag bit is set.

Before enabling the module in SPI Client mode, the clock line must match the proper Idle state. The clock line can be observed by reading the SCK pin. The Idle state is determined by the CKP bit.

While in Client mode, the external clock is supplied by the external clock source on the SCK pin. This external clock must meet the minimum high and low times as specified in Electrical Specifications.

While in Sleep mode, the client can transmit/receive data. The shift register is clocked from the SCK pin input and when a byte is received, the device will generate an interrupt. If enabled, the device will wake up from Sleep.

31.1.2.3 Daisy-Chain Configuration

The SPI bus can sometimes be connected in a daisy-chain configuration. The first client output is connected to the second client input, the second client output is connected to the third client input, and so on. The final client output is connected to the host input. Each client sends out, during a second group of clock pulses, an exact copy of what was received during the first group of clock pulses. The whole chain acts as one large communication shift register. The daisy-chain feature only requires a single Client Select line from the host device.

In a daisy-chain configuration, only the most recent byte on the bus is required by the client. Setting the Buffer Overwrite Enable (**BOEN**) bit will enable writes to the **SSPxBUF** register, even if the previous byte has not been read. This allows the software to ignore data that may not apply to it.

Figure 31-5 shows the block diagram of a typical daisy-chain connection when operating in SPI mode.

Figure 31-5. SPI Daisy-Chain Connection

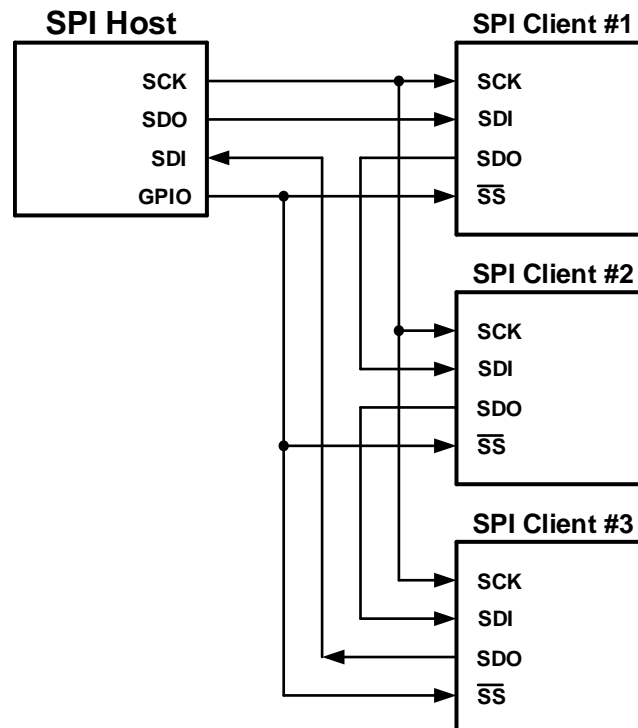

31.1.2.4 Client Select Synchronization

The Client Select can also be used to synchronize communication (see Figure 31-6). The Client Select line is held high until the host device is ready to communicate. When the Client Select line is pulled low, the client knows that a new transmission is starting.

If the client fails to receive the communication properly, it will be reset at the end of the transmission, when the Client Select line returns to a High state. The client is then ready to receive a new transmission when the Client Select line is pulled low again. If the Client Select line is not used, there is a risk that the client will eventually become out of sync with the host. If the client misses a bit, it will always be one bit off in future transmissions. Use of the Client Select line allows the client and host to align themselves at the beginning of each transmission.

The \overline{SS} pin allows a Synchronous Client mode. The SPI must be in Client mode with \overline{SS} pin control enabled (MSSP Mode Select (**SSPM**) bits = 0100).

When the \overline{SS} pin is low, transmission and reception are enabled and the SDO pin is driven.

When the \overline{SS} pin goes high, the SDO pin is no longer driven, even if in the middle of a transmitted byte, and becomes a floating output. External pull-up/pull-down resistors may be desirable depending on the application.

When the SPI module resets, the bit counter is forced to '0'. This can be done by either forcing the \overline{SS} pin to a high level or clearing the **SSPEN** bit.



Important:

1. When the SPI is in Client mode with \overline{SS} pin control enabled ($SSPM = 0100$), the SPI module will reset if the \overline{SS} pin is set to V_{DD} .
2. When the SPI is used in Client mode with **CKE** set, the user must enable \overline{SS} pin control (see [Figure 31-8](#)). If **CKE** is clear, \overline{SS} pin control is optional (see [Figure 31-7](#)).
3. While operated in SPI Client mode, the **SMP** bit must remain clear.

Figure 31-6. Client Select Synchronous Waveform

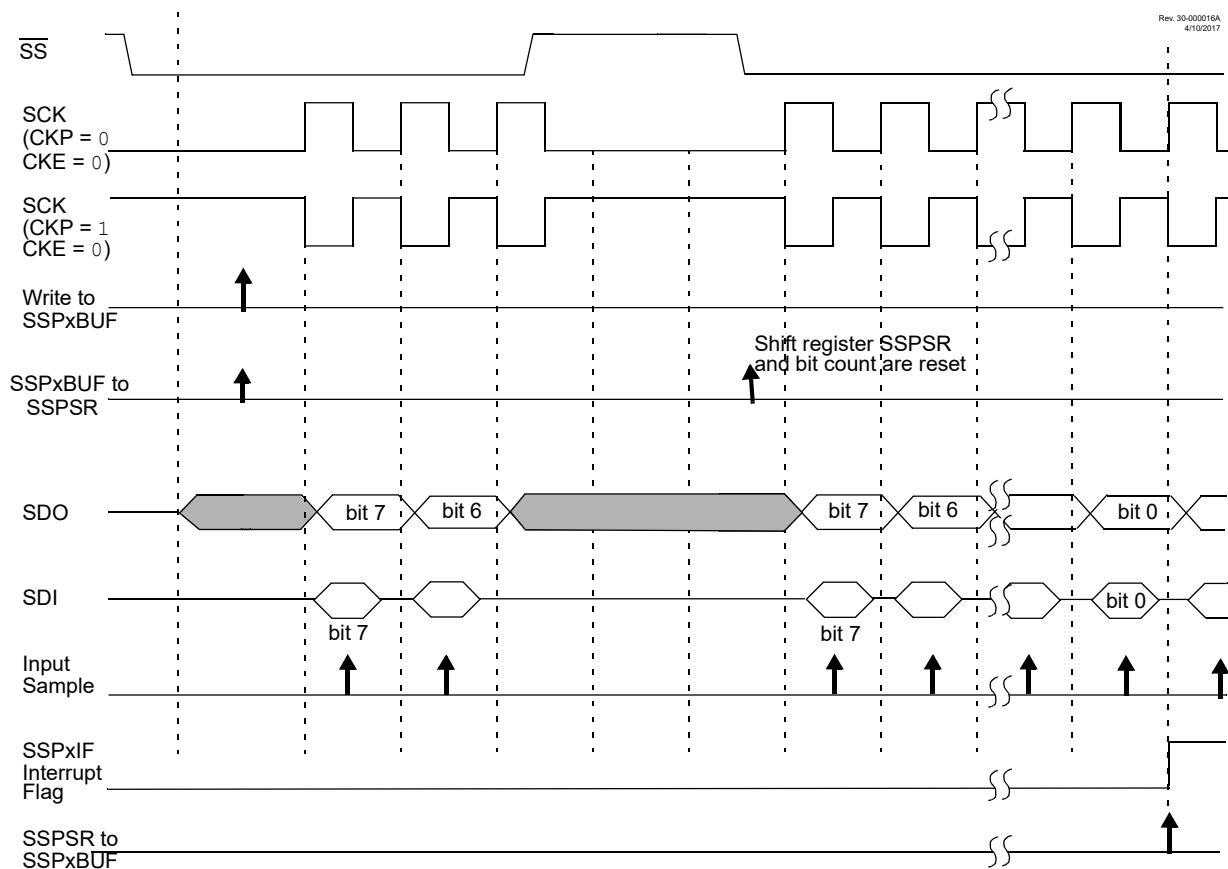

Figure 31-7. SPI Mode Waveform (Client Mode with CKE = 0)

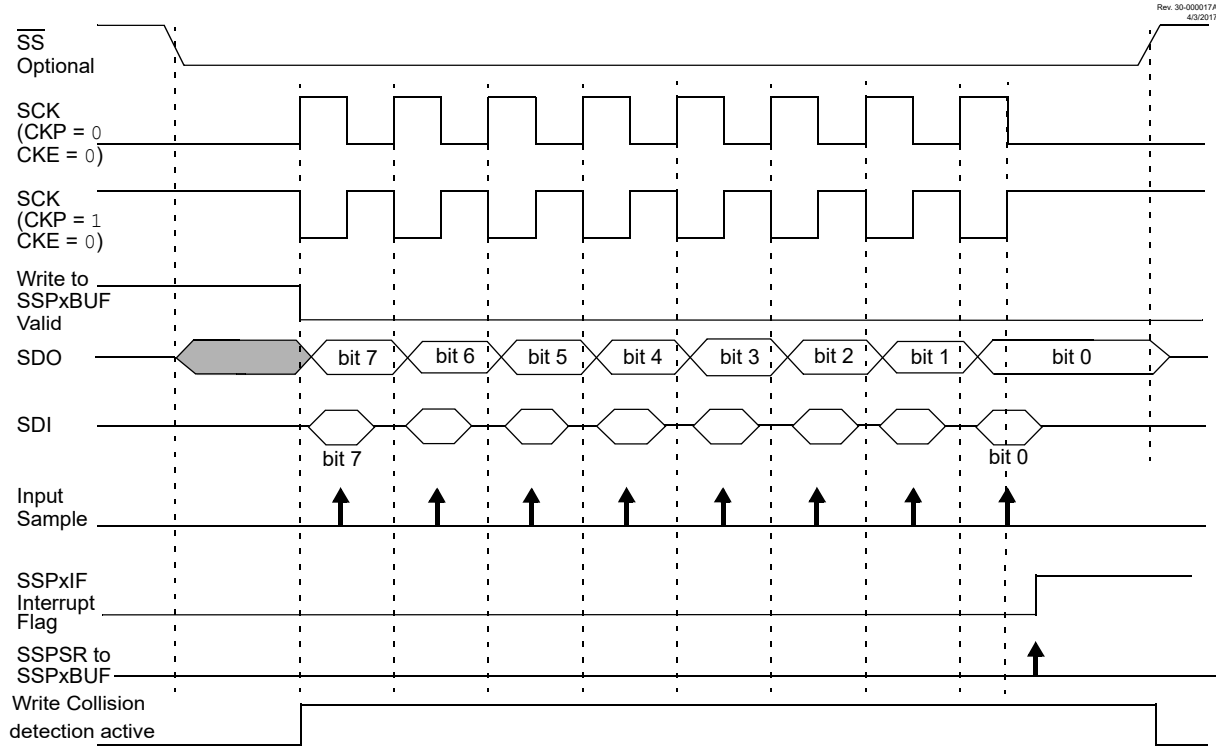
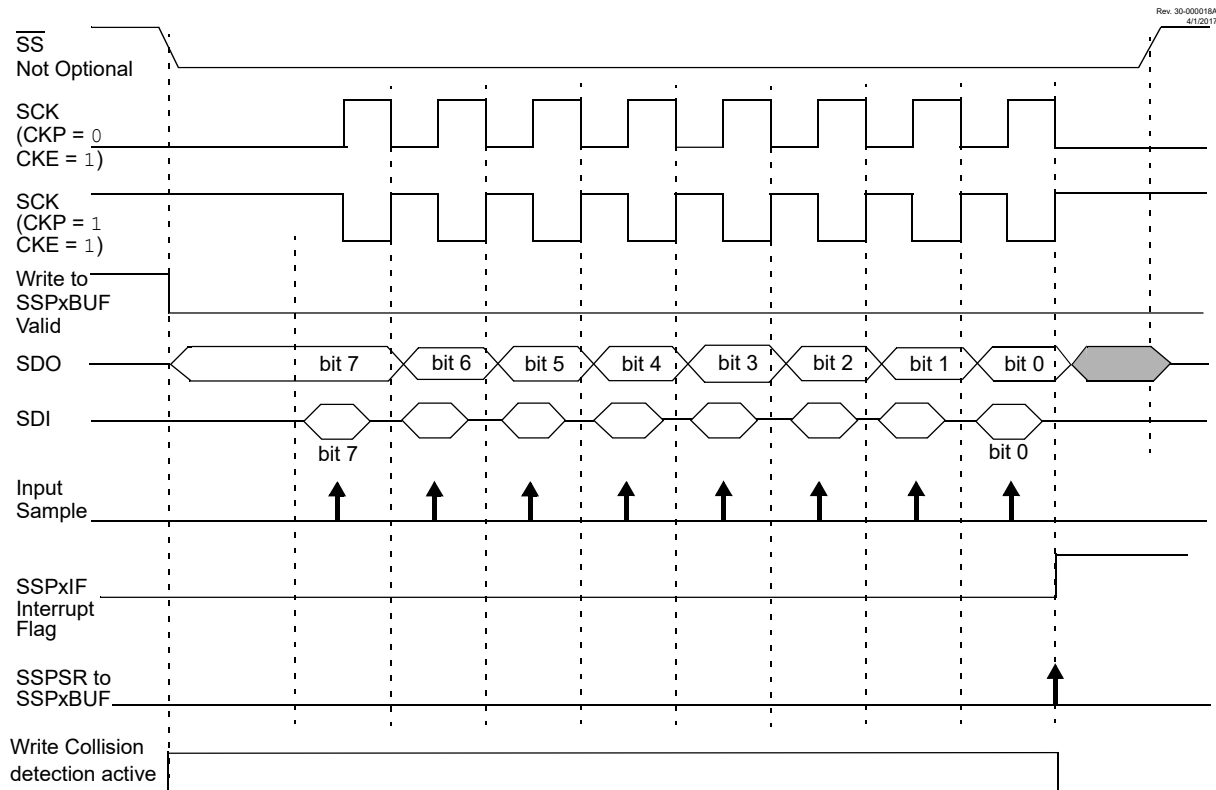

Figure 31-8. SPI Mode Waveform (Client Mode with CKE = 1)



31.1.2.5 SPI Operation in Sleep Mode

In SPI Host mode, when the Sleep mode is selected, all module clocks are halted and the transmission/reception will remain in that state until the device wakes. After the device returns to Run mode, the module will resume transmitting and receiving data.

In SPI Client mode, the SPI Transmit/Receive Shift register operates asynchronously to the device. This allows the device to be placed in Sleep mode and data to be shifted into the SPI Transmit/Receive Shift register. When all eight bits have been received, the MSSP Interrupt Flag bit will be set and if enabled, will wake the device.

31.2 I²C Mode Overview

The Inter-Integrated Circuit (I²C) bus is a multi-host serial data communication bus. Devices communicate in a host/client environment where the host devices initiate the communication. A client device is controlled through addressing. [Figure 31-9](#) and [Figure 31-10](#) show block diagrams of the I²C Host and Client modes, respectively.

Figure 31-9. MSSP Block Diagram (I²C Host Mode)

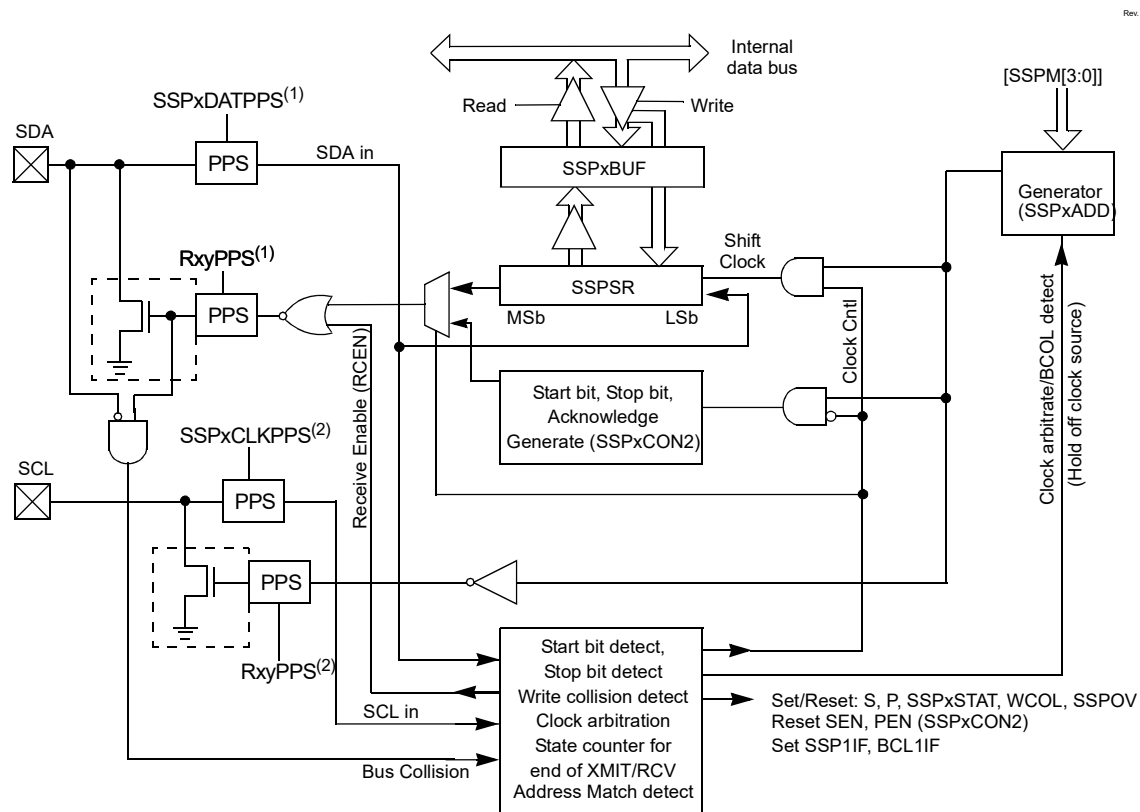

- Notes:** 1. SDA pin selections must be the same for input and output.
2. SCL pin selections must be the same for input and output.

Figure 31-10. MSSP Block Diagram (I²C Client Mode)

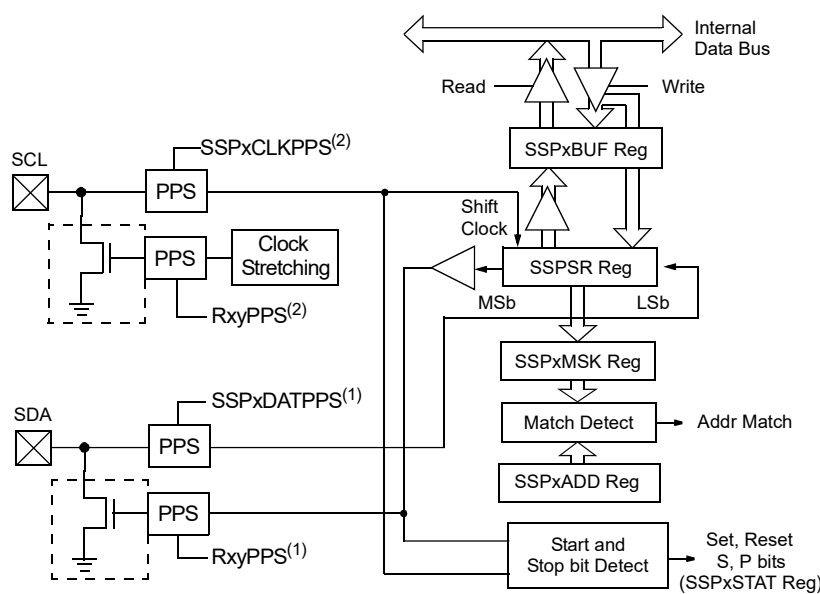

Rev. 30-000020A
4/3/2017

- Notes:**
1. SDA pin selections must be the same for input and output.
 2. SCL pin selections must be the same for input and output.

The I²C bus specifies two signal connections:

- Serial Clock (SCL)
- Serial Data (SDA)

Both the SCL and SDA connections are bidirectional open-drain lines, each requiring pull-up resistors for the supply voltage. Pulling the line to ground is considered a logical zero and letting the line float is considered a logical one.

Figure 31-11 shows a typical connection between two processors configured as host and client devices.

Figure 31-11. I²C Host/Client Connection

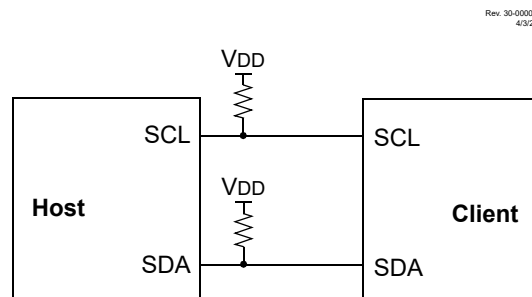

Rev. 30-000021A
4/3/2017

The I²C bus can operate with one or more host devices and one or more client devices.

There are four potential modes of operation for a given device:

- Host Transmit mode (host is transmitting data to a client)
- Host Receive mode (host is receiving data from a client)

- Client Transmit mode (client is transmitting data to a host)
- Client Receive mode (client is receiving data from the host)

To begin communication, the host device transmits a Start condition followed by the address byte of the client it intends to communicate with. A Start condition is indicated by a high-to-low transition of the SDA line while the SCL line is held high. Address and data bytes are sent out, MSb first. This is followed by a single Read/Write Information (R/W) bit, which determines whether the host intends to transmit to or receive data from the client device. The R/W bit is sent out as a logical one when the host intends to read data from the client and is sent out as a logical zero when it intends to write data to the client.

If the requested client exists on the bus, it will respond with an Acknowledge sequence, otherwise known as an $\overline{\text{ACK}}$. The Acknowledge sequence is an active-low signal, which holds the SDA line low to indicate to the transmitter that the client device has received the transmitted data and is ready to receive more. The host then continues to either transmit to or receive data from the client.

The transition of a data bit is always performed while the SCL line is held low. Transitions that occur while the SCL line is held high are used to indicate Start and Stop conditions.

If the host intends to write to the client, then it repeatedly sends out a byte of data, with the client responding after each byte with an $\overline{\text{ACK}}$ sequence. In this example, the host device is in Host Transmit mode and the client is in Client Receive mode.

If the host intends to read from the client, then it repeatedly receives a byte of data from the client and responds after each byte with an $\overline{\text{ACK}}$ sequence. In this example, the host device is in Host Receive mode and the client is in Client Transmit mode.

On the last byte of data communicated, the host device may end the transmission by sending a Stop condition. If the host device is in Receive mode, it sends the Stop condition in place of the last $\overline{\text{ACK}}$ sequence. A Stop condition is indicated by a low-to-high transition of the SDA line while the SCL line is held high.

In some cases, the host may want to maintain control of the bus and re-initiate another transmission. If so, the host device may send a Restart condition in place of the Stop condition or last $\overline{\text{ACK}}$ sequence when it is in Receive mode.

The I²C bus specifies three message protocols:

- Single message where a host writes data to a client.
- Single message where a host reads data from a client.
- Combined message where a host initiates a minimum of two writes, two reads, or a combination of writes and reads, to one or more clients.

31.2.1 I²C Mode Registers

The MSSP module has eight registers for I²C operation.

These are:

- MSSP Status Register ([SSPxSTAT](#))
- MSSP Control 1 Register ([SSPxCON1](#))
- MSSP Control 2 Register ([SSPxCON2](#))
- MSSP Control 3 Register ([SSPxCON3](#))
- Serial Receive/Transmit Buffer Register ([SSPxBUF](#))
- MSSP Address Register ([SSPxADD](#))
- I²C Client Address Mask Register ([SSPxMSK](#))
- MSSP Shift (SSPSR) register – not directly accessible

SSPxCON1, SSPxCON2, SSPxCON3 and SSPxSTAT are the Control and Status registers in I²C mode operation. The SSPxCON1, SSPxCON2 and SSPxCON3 registers are readable and writable. The lower six bits of the SSPxSTAT are read-only. The upper two bits of the SSPxSTAT are read/write. SSPxMSK holds the client address mask value used in address comparison. SSPxADD contains the client device address when the MSSP is configured in I²C Client mode. When the MSSP is configured in Host mode, SSPxADD acts as the Baud Rate Generator reload value.

SSPSR is the shift register used for shifting data in or out. SSPxBUF is the buffer register to which data bytes are written to or read from. In receive operations, SSPSR and SSPxBUF together, create a double-buffered receiver. When SSPSR receives a complete byte, it is transferred to SSPxBUF and the SSPxIF interrupt is set. During transmission, the SSPxBUF is not double-buffered. A write to SSPxBUF will write to both SSPxBUF and SSPSR.

31.2.2 I²C Mode Operation

All MSSP I²C communication is byte oriented and shifted out MSb first. Eight SFR registers and two interrupt flags interface the module with the PIC[®] microcontroller and user software. Two pins, SDA and SCL, are exercised by the module to communicate with other external I²C devices.

31.2.2.1 Definition of I²C Terminology

There is language and terminology in the description of I²C communication that have definitions specific to I²C. That word usage is defined below and may be used in the rest of this document without explanation. This table was adapted from the Philips/NXP I²C Specification.

Table 31-1. I²C Terminology

Term	Description
Transmitter	The device that shifts data out onto the bus
Receiver	The device that shifts data in from the bus
Host	The device that initiates a transfer, generates clock signals, and terminates a transfer
Client	The device addressed by the host
Multi-Host	A bus with more than one device that can initiate data transfers
Arbitration	Procedure to ensure that only one host at a time controls the bus. Winning arbitration ensures that the message is not corrupted.
Synchronization	Procedure to synchronize the clocks of two or more devices on the bus
Idle	No host is controlling the bus, and both SDA and SCL lines are high
Active	Any time one or more host devices are controlling the bus
Addressed Client	Client device that has received a matching address and is actively being clocked by a host
Matching Address	Address byte that is clocked into a client that matches the value stored in SSPxADD
Write Request	Client receives a matching address with the R/W bit clear and is ready to clock in data
Read Request	Host sends an address byte with the R/W bit set, indicating that it wishes to clock data out of the client. This data is next and all following bytes until a Restart or Stop.
Clock Stretching	When a device on the bus hold SCL low to stall communication
Bus Collision	Any time the SDA line is sampled low by the module while it is outputting and expected High state

31.2.2.2 Byte Format

All communication in I²C is done in 9-bit segments. A byte is sent from a host to a client or vice versa, followed by an Acknowledge sequence sent back. After the eighth falling edge of the SCL line, the device outputting data on the SDA changes that pin to an input and reads the Acknowledge value on the next clock pulse.

The clock signal, SCL, is provided by the host. Data are valid to change while the SCL signal is low and is sampled on the rising edge of the clock. Changes on the SDA line while the SCL line is high define special conditions on the bus, such as a Start or Stop condition.

31.2.2.3 SDA and SCL Pins

Selection of any I²C mode with the [SSPEN](#) bit set forces the SCL and SDA pins to be open-drain. These pins must be configured as inputs by setting the appropriate TRIS bits.



Important: Any device pin can be selected for SDA and SCL functions with the PPS peripheral. These functions are bidirectional. The SDA input is selected with the SSPxDATPPS registers. The SCL input is selected with the SSPxCLKPPS registers. Outputs are selected with the RxyPPS registers. It is the user's responsibility to make the selections so that both the input and the output for each function is on the same pin.

31.2.2.4 SDA Hold Time

The hold time of the SDA pin is selected by the SDA Hold Time Selection ([SDAHT](#)) bit. Hold time is the time SDA is held valid after the falling edge of SCL. Setting the SDAHT bit selects a longer 300 ns minimum hold time and may help buses with large capacitance.

31.2.2.5 Clock Stretching

Clock stretching occurs when a device on the bus holds the SCL line low, effectively pausing communication. The client may stretch the clock to allow more time to handle data or prepare a response for the host device. A host device is not concerned with stretching as anytime it is active on the bus and not transferring data it is stretching. Any stretching done by a client is invisible to the host software and handled by the hardware that generates SCL.

The [CKP](#) bit is used to control stretching in software. Any time the CKP bit is cleared, the module will wait for the SCL line to go low and then hold it. Setting CKP will release SCL and allow more communication.

31.2.2.6 Arbitration

Each host device must monitor the bus for Start and Stop conditions. If the device detects that the bus is busy, it cannot begin a new message until the bus returns to an Idle state.

However, two host devices may try to initiate a transmission on or about the same time. When this occurs, the process of arbitration begins. Each transmitter checks the level of the SDA data line and compares it to the level that it expects to find. The first transmitter to observe that the two levels do not match loses arbitration and must stop transmitting on the SDA line.

For example, if one transmitter holds the SDA line to a logical one (lets SDA float) and a second transmitter holds it to a logical zero (pulls SDA low), the result is that the SDA line will be low. The first transmitter then observes that the level of the line is different than expected and concludes that another transmitter is communicating.

The first transmitter to notice this difference is the one that loses arbitration and must stop driving the SDA line. If this transmitter is also a host device, it also must stop driving the SCL line. It then can monitor the lines for a Stop condition before trying to reissue its transmission. In the meantime, the other device that has not noticed any difference between the expected and actual levels on the SDA line continues with its original transmission. It can do so without any complications, because so far, the transmission appears exactly as expected with no other transmitter disturbing the message.

Client Transmit mode can also be arbitrated, when a host addresses multiple clients, but this is less common.

31.2.2.7 Start Condition

The I²C Specification defines a Start condition as a transition of SDA from a High to a Low state while SCL line is high. A Start condition is always generated by the host and signifies the transition of the bus from an Idle to an Active state. [Figure 31-12](#) shows wave forms for Start and Stop conditions.

A bus collision can occur on a Start condition if the module samples the SDA line low before asserting it low. This does not conform to the I²C Specification that states no bus collision can occur on a Start.

31.2.2.8 Stop Condition

A Stop condition is a transition of the SDA line from Low-to-High state while the SCL line is high.



Important: At least one SCL low time must appear before a Stop is valid, therefore, if the SDA line goes low then high again while the SCL line stays high, only the Start condition is detected.

Figure 31-12. I²C Start and Stop Conditions

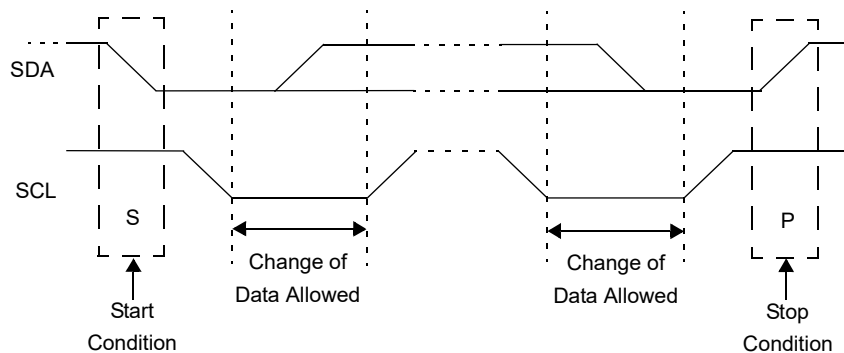

31.2.2.9 Start/Stop Condition Interrupt Masking

The Start Condition Interrupt Enable (SCIE) and Stop Condition Interrupt Enable (PCIE) bits can enable the generation of an interrupt in Client modes that do not typically support this function. These bits will have no effect in Client modes where interrupt on Start and Stop detect are already enabled.

31.2.2.10 Restart Condition

A Restart condition is valid any time that a Stop is valid. A host can issue a Restart if it wishes to hold the bus after terminating the current transfer. A Restart has the same effect on the client that a Start would, resetting all client logic and preparing it to clock in an address. The host may want to address the same or another client. Figure 31-13 shows the waveform for a Restart condition.

In 10-bit Addressing Client mode, a Restart is required for the host to clock data out of the addressed client. Once a client has been fully addressed, matching both high and low address bytes, the host can issue a Restart and the high address byte with the R/W bit set. The client logic will then hold the clock and prepare to clock out data.

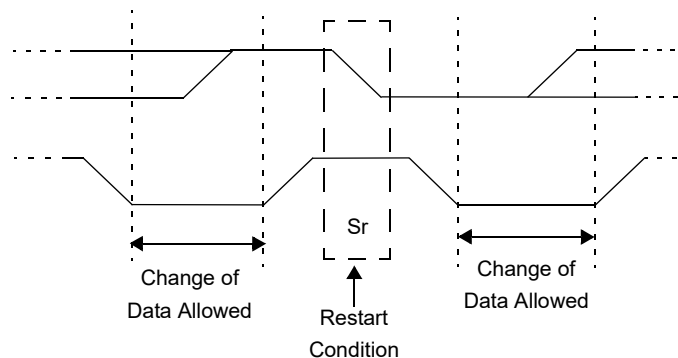
Figure 31-13. I²C Restart ConditionRev. 30-00023A
4/9/2017

31.2.2.11 Acknowledge Sequence

The ninth SCL pulse for any transferred byte in I²C is dedicated as an Acknowledge sequence ($\overline{\text{ACK}}$). It allows receiving devices to respond back to the transmitter by pulling the SDA line low. The transmitter must release control of the line during this time to shift in the response. The Acknowledge ($\overline{\text{ACK}}$) is an active-low signal, pulling the SDA line low indicates to the transmitter that the device has received the transmitted data and is ready to receive more.

The result of an $\overline{\text{ACK}}$ is placed in the Acknowledge Status (**ACKSTAT**) bit.

The client software, when the Address Hold Enable (**AHEN**) and Data Hold Enable (**DHEN**) bits are set, allows the user to select the $\overline{\text{ACK}}$ value sent back to the transmitter. The Acknowledge Data (**ACKDT**) bit is set/cleared to determine the response.

The client hardware will generate an $\overline{\text{ACK}}$ response under most circumstances. However, if the **BF** bit or the Receive Overflow Indicator (**SSPOV**) bit are set when a byte is received then the $\overline{\text{ACK}}$ will not be sent by the client.

When the module is addressed, after the eighth falling edge of SCL on the bus, the Acknowledge Time Status (**ACKTIM**) bit is set. The **ACKTIM** bit indicates the acknowledge time of the active bus. The **ACKTIM** bit is only active when either the **AHEN** bit or **DHEN** bit is enabled.

31.2.3 I²C Client Mode Operation

The MSSP Client mode operates in one of four modes selected by the MSSP Mode Select (**SSPM**) bits. The modes can be divided into 7-bit and 10-bit Addressing mode. 10-bit Addressing modes operate the same as 7-bit with some additional overhead for handling the larger addresses.

Modes with Start and Stop condition interrupts operate the same as the other modes with **SSPxIF** additionally getting set upon detection of a Start, Restart, or Stop condition.

31.2.3.1 Client Mode Addresses

The **SSPxADD** register contains the Client mode address. The first byte received after a Start or Restart condition is compared against the value stored in this register. If the byte matches, the value is loaded into the **SSPxBUF** register and an interrupt is generated. If the value does not match, the module goes Idle and no indication is given to the software that anything happened.

The **SSPxMSK** register affects the address matching process. See [SSP Mask Register](#) for more information.

31.2.3.1.1 I²C Client 7-Bit Addressing Mode

In 7-bit Addressing mode, the LSb of the received data byte is ignored when determining if there is an address match.

31.2.3.1.2 I²C Client 10-Bit Addressing Mode

In 10-bit Addressing mode, the first received byte is compared to the binary value of '1 1 1 0 A9 A8 0'. A9 and A8 are the two MSBs of the 10-bit address and stored in bits 2 and 1 of the **SSPxADD** register.

After the acknowledge of the high byte the Update Address (**UA**) bit is set and SCL is held low until the user updates **SSPxADD** with the low address. The low address byte is clocked in and all eight bits are compared to the low address value in **SSPxADD**. Even if there is not an address match, **SSPxIF** and **UA** are set, and SCL is held low until **SSPxADD** is updated to receive a high byte again. When **SSPxADD** is updated the **UA** bit is cleared. This ensures the module is ready to receive the high address byte on the next communication.

A high and low address match as a write request is required at the start of all 10-bit addressing communication. A transmission can be initiated by issuing a Restart once the client is addressed and clocking in the high address with the **R/W** bit set. The client hardware will then acknowledge the read request and prepare to clock out data. This is only valid for a client after it has received a complete high and low address byte match.

31.2.3.2 Clock Stretching

Clock stretching occurs when a device on the bus holds the SCL line low, effectively pausing communication. The client may stretch the clock to allow more time to handle data or prepare a response for the host device. A host device is not concerned with stretching as anytime it is active on the bus and not transferring data it is stretching. Any stretching done by a client is invisible to the host software and handled by the hardware that generates SCL.

The **CKP** bit is used to control stretching in software. Any time the **CKP** bit is cleared, the module will wait for the SCL line to go low and then hold it. Setting **CKP** will release SCL and allow more communication.

31.2.3.2.1 Normal Clock Stretching

Following an $\overline{\text{ACK}}$ if the **R/W** bit is set (a read request), the client hardware will clear **CKP**. This allows the client time to update **SSPxBUF** with data to transfer to the host. If the Stretch Enable (**SEN**) bit is set, the client hardware will always stretch the clock after the $\overline{\text{ACK}}$ sequence. Once the client is ready, **CKP** is set by software and communication resumes.

31.2.3.2.2 10-Bit Addressing Mode

In 10-bit Addressing mode, when the **UA** bit is set, the clock is always stretched. This is the only time the SCL is stretched without **CKP** being cleared. SCL is released immediately after a write to **SSPxADD**.

31.2.3.2.3 Byte NACKing

When the **AHEN** bit is set, **CKP** is cleared by hardware after the eighth falling edge of SCL for a received matching address byte. When the **DHEN** bit is set, **CKP** is cleared after the eighth falling edge of SCL for received data.

Stretching after the eighth falling edge of SCL allows the client to look at the received address or data and decide if it wants to acknowledge ($\overline{\text{ACK}}$) the received address or data or not acknowledge (**NACK**) the address or data.

31.2.3.3 Clock Synchronization and the CKP Bit

Any time the **CKP** bit is cleared, the module will wait for the SCL line to go low and then hold it. However, clearing the **CKP** bit will not assert the SCL output low until the SCL output is already sampled low. Therefore, the **CKP** bit will not assert the SCL line until an external I²C host device has already asserted the SCL line. The SCL output will remain low until the **CKP** bit is set and all other devices on the I²C bus have released SCL.

31.2.3.4 General Call Address Support

The addressing procedure for the I²C bus is such that the first byte after the Start condition usually determines which device will be the client addressed by the host device. The exception is the

General Call address that can address all devices. When this address is used, all devices must, in theory, respond with an $\overline{\text{ACK}}$.

The general call address is a reserved address in the I²C protocol, defined as address 0x00. When the General Call Enable (**GCEN**) bit is set, the client module will automatically $\overline{\text{ACK}}$ the reception of this address regardless of the value stored in **SSPxADD**. After the client clocks in an address of all zeros with the **R/W** bit clear, an interrupt is generated and client software can read **SSPxBUF** and respond. Figure 31-14 shows a General Call reception sequence.

Figure 31-14. Client Mode General Call Address Sequence

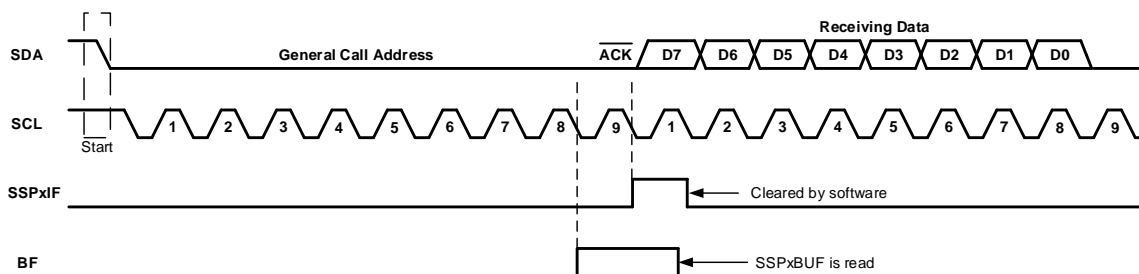

In 10-bit Address mode, the **UA** bit will not be set on the reception of the general call address. The client will prepare to receive the second byte as data, just as it would in 7-bit mode.

If the **AHEN** bit is set, just as with any other address reception, the client hardware will stretch the clock after the eighth falling edge of SCL. The client must then set its Acknowledge Sequence Enable (**ACKEN**) bit and release the clock.

31.2.3.5 SSP Mask Register

The MSSP Mask (**SSPxMSK**) register is available in I²C Client mode as a mask for the value held in the SSPSR register during an address comparison operation. A zero ('0') bit in the SSPxMSK register has the effect of making the corresponding bit of the received address a "don't care".

This register is reset to all '1's upon any Reset condition and, therefore, has no effect on standard MSSP operation until written with a mask value.

SSPxMSK is active during:

- 7-bit Address mode: Address compare of A[7:1]
- 10-bit Address mode: Address compare of A[7:0] only. The MSSP mask has no effect during the reception of the first (high) byte of the address.

31.2.3.6 Client Reception

When the **R/W** bit of a matching received address byte is clear, the **R/W** bit is cleared. The received address is loaded into the **SSPxBUF** register and acknowledged.

When the Overflow condition exists for a received address, a Not Acknowledge (NACK) is transmitted and the Receive Overflow Indicator (**SSPOV**) bit is set. The Buffer Override Enable (**BOEN**) bit modifies this operation.

An MSSP interrupt is generated for each transferred data byte. The SSPxIF flag bit must be cleared by software.

When the **SEN** bit is set, SCL will be held low (clock stretch) following each received byte. The clock must be released by setting the **CKP** bit, except sometimes in 10-bit mode. See [10-Bit Addressing Mode](#) for more details.

31.2.3.6.1 7-Bit Addressing Reception

This section describes a standard sequence of events for the MSSP module configured as an I²C client in 7-bit Addressing mode. [Figure 31-15](#) and [Figure 31-16](#) are used as a visual reference for this description.

This is a step by step process of what typically must be done to accomplish I²C communication.

1. Start condition detected.
2. The Start (S) bit is set; SSPxIF is set if the Start Condition Interrupt Enable (SCIE) bit is set.
3. Matching address with $\overline{R/W}$ bit clear is received.
4. The client pulls SDA low, sends an \overline{ACK} to the host, and sets the SSPxIF bit.
5. Software clears the SSPxIF bit.
6. Software reads received address from SSPxBUF, clearing the BF flag.
7. If SEN = 1; Client software sets the CKP bit to release the SCL line.
8. The host clocks out a data byte.
9. The client drives SDA low, sends an \overline{ACK} to the host, and sets the SSPxIF bit.
10. Software clears SSPxIF.
11. Software reads the received byte from SSPxBUF, clearing BF.
12. Steps 8-12 are repeated for all received bytes from the host.
13. Host sends Stop condition, setting the Stop (P) bit, and the bus goes Idle.

Figure 31-15. I²C Client, 7-Bit Address, Reception (SEN = 0, AHEN = 0, DHEN = 0)

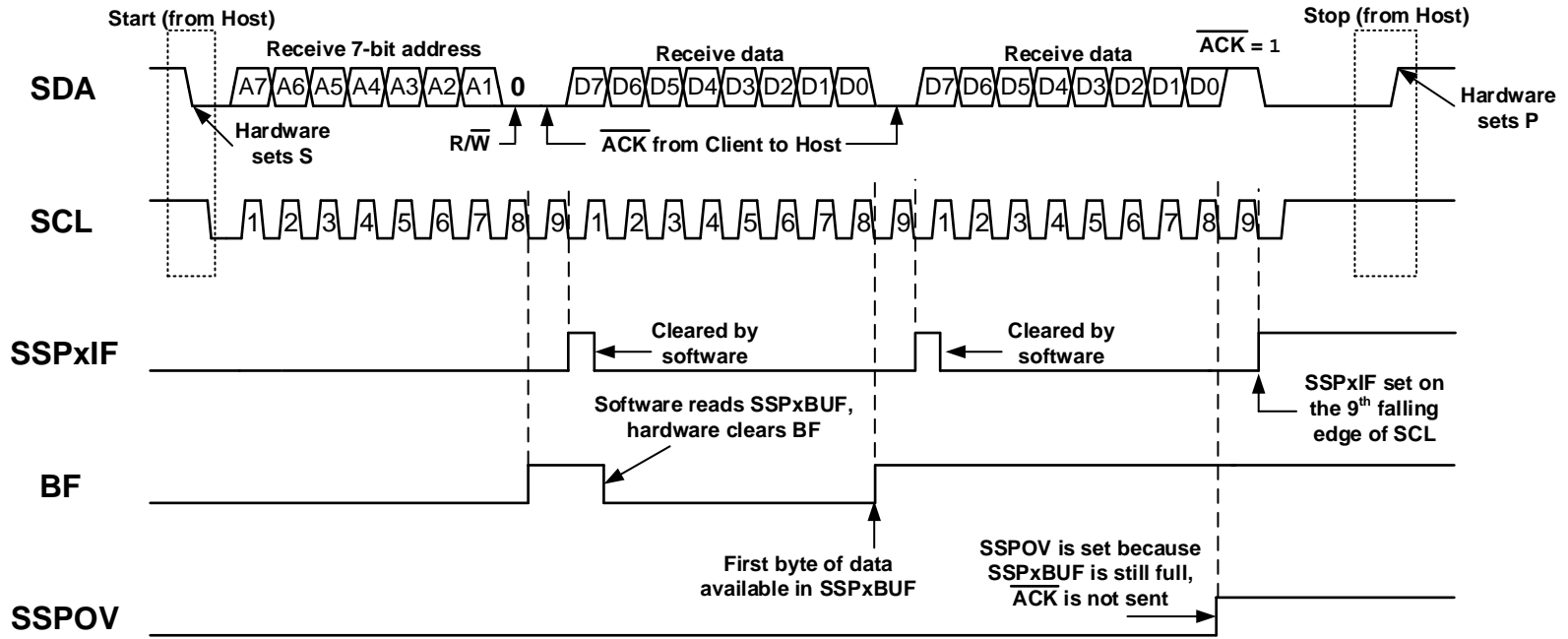
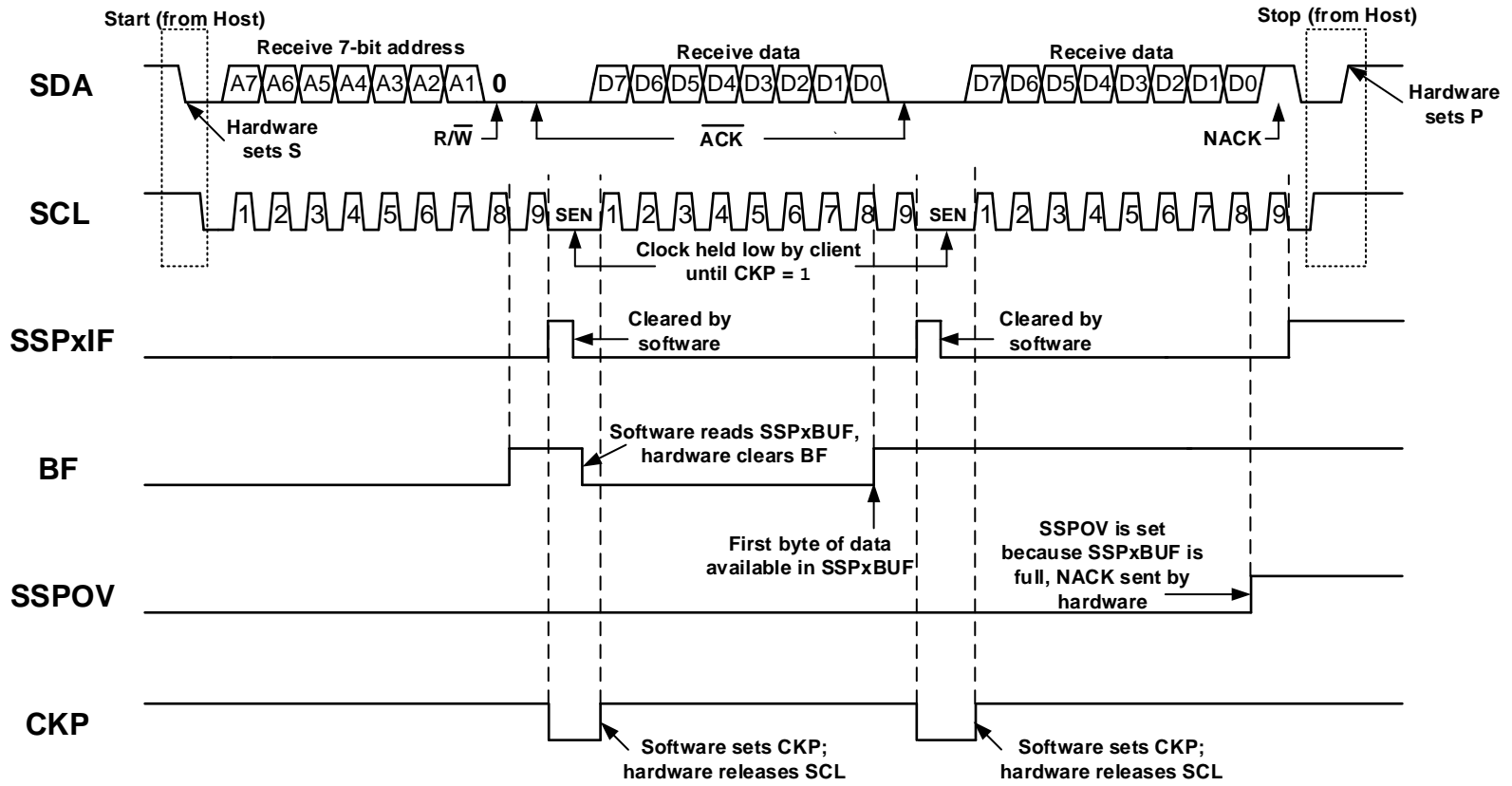

Figure 31-16. I²C Client, 7-Bit Address, Reception (SEN = 1, AHEN = 0, DHEN = 0)



31.2.3.6.2 7-Bit Reception with AHEN and DHEN

Client device reception with **AHEN** and **DHEN** set operate the same as without these options with extra interrupts and clock stretching added after the eighth falling edge of SCL. These additional interrupts allow the client software to decide whether it wants to $\overline{\text{ACK}}$ the receive address or data byte, rather than the hardware. This functionality adds support for PMBus™ that was not present on previous versions of this module.

This list describes the steps that need to be taken by client software to use these options for I²C communication. [Figure 31-17](#) displays a module using both address and data holding. [Figure 31-18](#) includes the operation with the **SEN** bit set.

1. The Start (**S**) bit is set; SSPxIF is set if **SCIE** is set.
2. Matching address with the **R/W** bit clear is clocked in. SSPxIF is set and **CKP** cleared after the eighth falling edge of SCL.
3. Software clears the SSPxIF.
4. Client can look at the **ACKTIM** bit to determine if the SSPxIF was after or before the $\overline{\text{ACK}}$.
5. Client reads the address value from **SSPxBUF**, clearing the **BF** flag.
6. Client transmits an $\overline{\text{ACK}}$ to the host by clearing **ACKDT**.
7. Client releases the clock by setting **CKP**.
8. SSPxIF is set after an $\overline{\text{ACK}}$, not after a NACK.
9. If **SEN** = 1, the client hardware will stretch the clock after the $\overline{\text{ACK}}$.
10. Client clears SSPxIF.



Important: SSPxIF is still set after the ninth falling edge of SCL even if there is no clock stretching and BF has been cleared. Only if a NACK is sent to the host is SSPxIF not set.

11. SSPxIF is set and **CKP** cleared after eighth falling edge of SCL for a received data byte.
12. Client looks at the **ACKTIM** bit to determine the source of the interrupt.
13. Client reads the received data from **SSPxBUF**, clearing **BF**.
14. Steps 7-14 are the same for each received data byte.
15. Communication is ended by either the client sending a NACK or the host sending a Stop condition. If a Stop is sent and the Stop Condition Interrupt Enable (**PCIE**) bit is clear, the client will only know by polling the Stop (**P**) bit.

Figure 31-17. I²C Client, 7-Bit Address, Reception (SEN = 0, AHEN = 1, DHEN = 1)

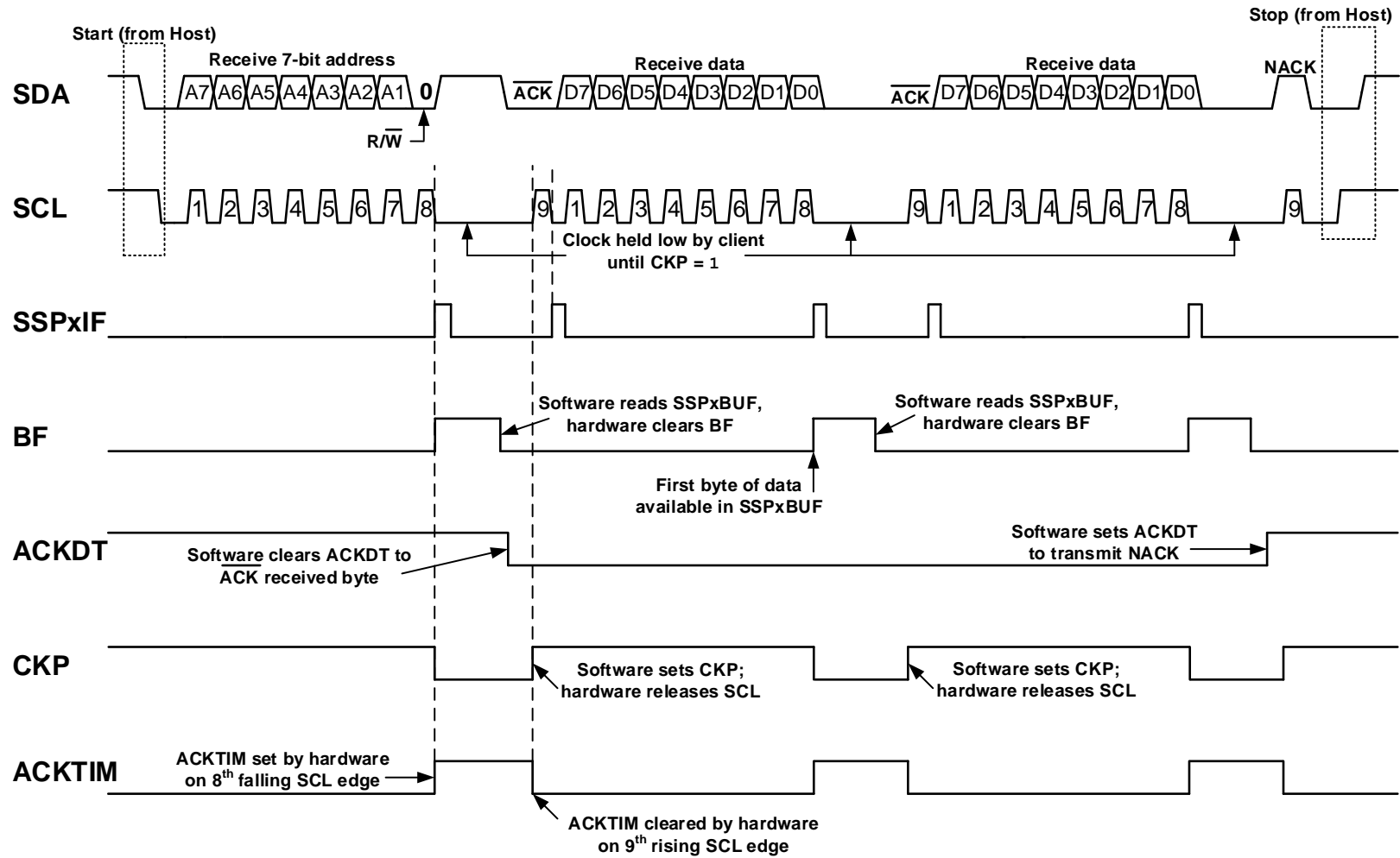
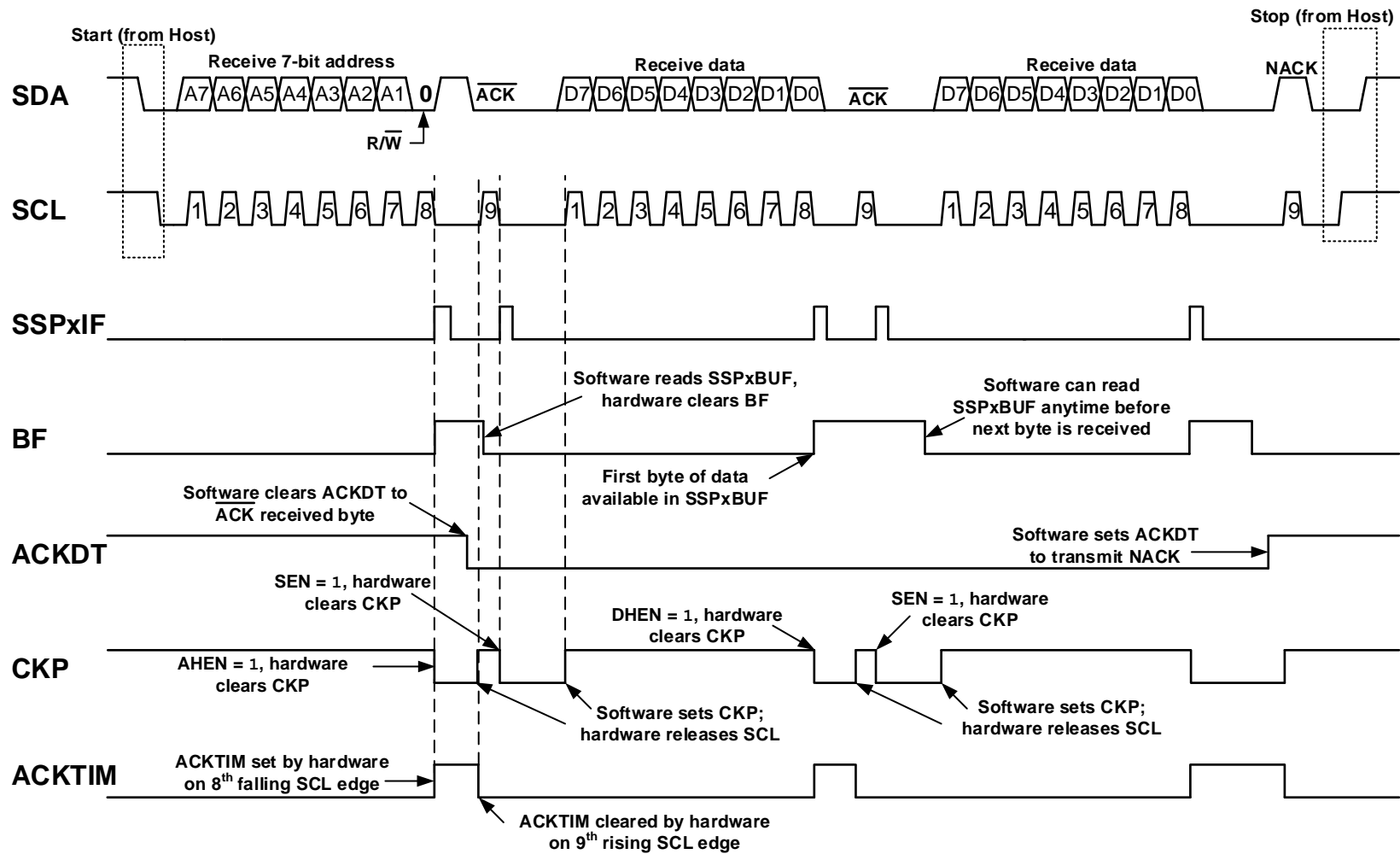

Figure 31-18. I²C Client, 7-Bit Address, Reception (SEN = 1, AHEN = 1, DHEN = 1)



31.2.3.6.3 Client Mode 10-Bit Address Reception

This section describes a standard sequence of events for the MSSP module configured as an I²C client in 10-bit Addressing mode. Figure 31-19 shows a standard waveform for a client receiver in 10-bit Addressing mode with clock stretching enabled.

This is a step-by-step process of what must be done by the client software to accomplish I²C communication.

1. Bus starts Idle.
2. Host sends Start condition; **S** bit is set; SSPxIF is set if **SCIE** is set.
3. Host sends matching high address with the **R/W** bit clear; the **UA** bit is set.
4. Client sends $\overline{\text{ACK}}$ and SSPxIF is set.
5. Software clears the SSPxIF bit.
6. Software reads received address from **SSPxBUF**, clearing the **BF** flag.
7. Client loads low address into **SSPxADD**, releasing SCL.
8. Host sends matching low address byte to the client; **UA** bit is set.



Important: Updates to the SSPxADD register are not allowed until after the $\overline{\text{ACK}}$ sequence.

9. Client sends $\overline{\text{ACK}}$ and SSPxIF is set.



Important: If the low address does not match, SSPxIF and UA are still set so that the client software can set SSPxADD back to the high address. BF is not set because there is no match. **CKP** is unaffected.

10. Client clears SSPxIF.
11. Client reads the received matching address from SSPxBUF, clearing BF.
12. Client loads high address into SSPxADD.
13. Host clocks a data byte to the client and clocks out the client $\overline{\text{ACK}}$ on the ninth SCL pulse; SSPxIF is set.
14. If the **SEN** bit is set, **CKP** is cleared by hardware and the clock is stretched.
15. Client clears SSPxIF.
16. Client reads the received byte from SSPxBUF, clearing BF.
17. If **SEN** is set the client software sets **CKP** to release the SCL.
18. Steps 13-17 repeat for each received byte.
19. Host sends Stop to end the transmission.

Figure 31-19. I²C Client, 10-Bit Address, Reception (SEN = 1, AHEN = 0, DHEN = 0)

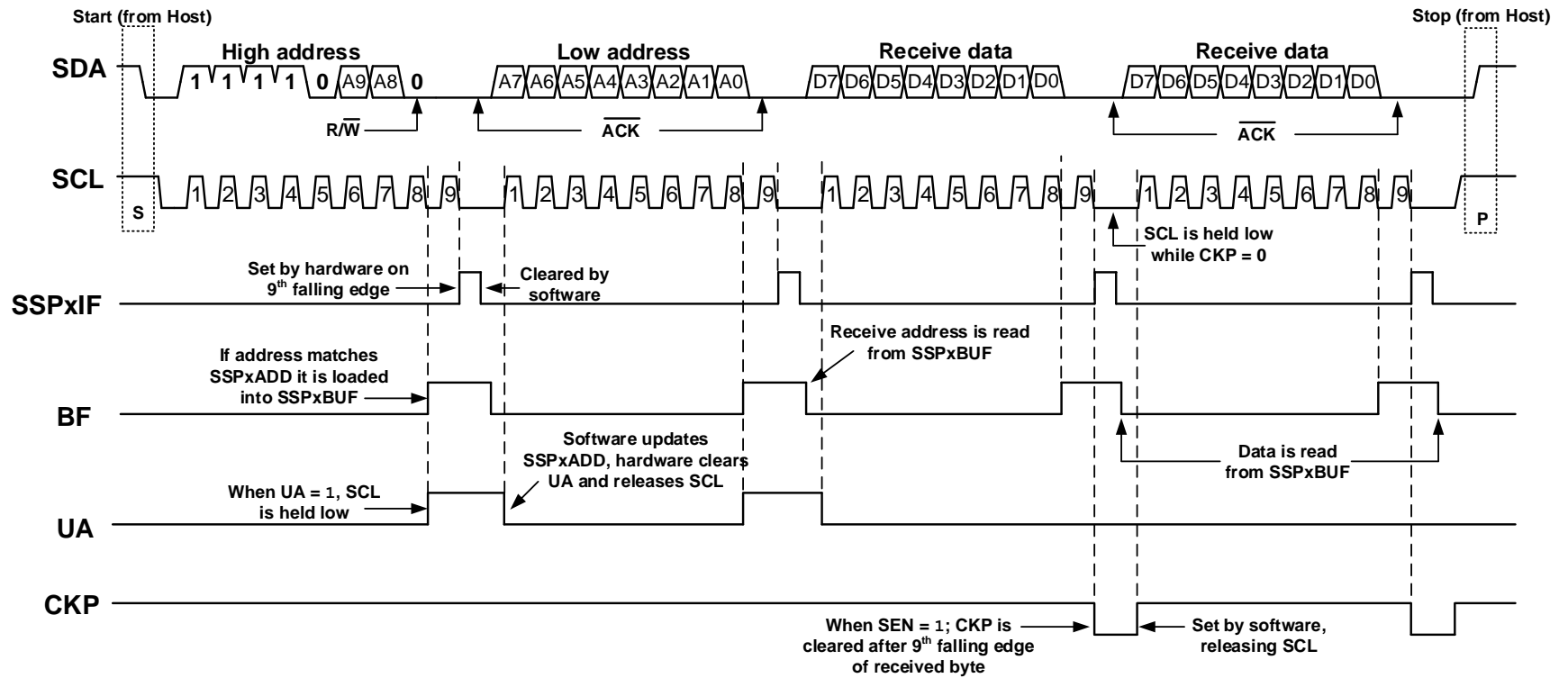

31.2.3.6.4 10-Bit Addressing with Address or Data Hold

Reception using 10-bit addressing with **AHEN** or **DHEN** set is the same as with 7-bit modes. The only difference is the need to update the **SSPxADD** register using the **UA** bit. All functionality, specifically when the **CKP** bit is cleared and SCL line is held low, are the same. [Figure 31-20](#) can be used as a reference of a client in 10-bit addressing with **AHEN** set.

[Figure 31-21](#) shows a standard waveform for a client transmitter in 10-bit Addressing mode.

Figure 31-20. I²C Client, 10-Bit Address, Reception (SEN = 0, AHEN = 1, DHEN = 0)

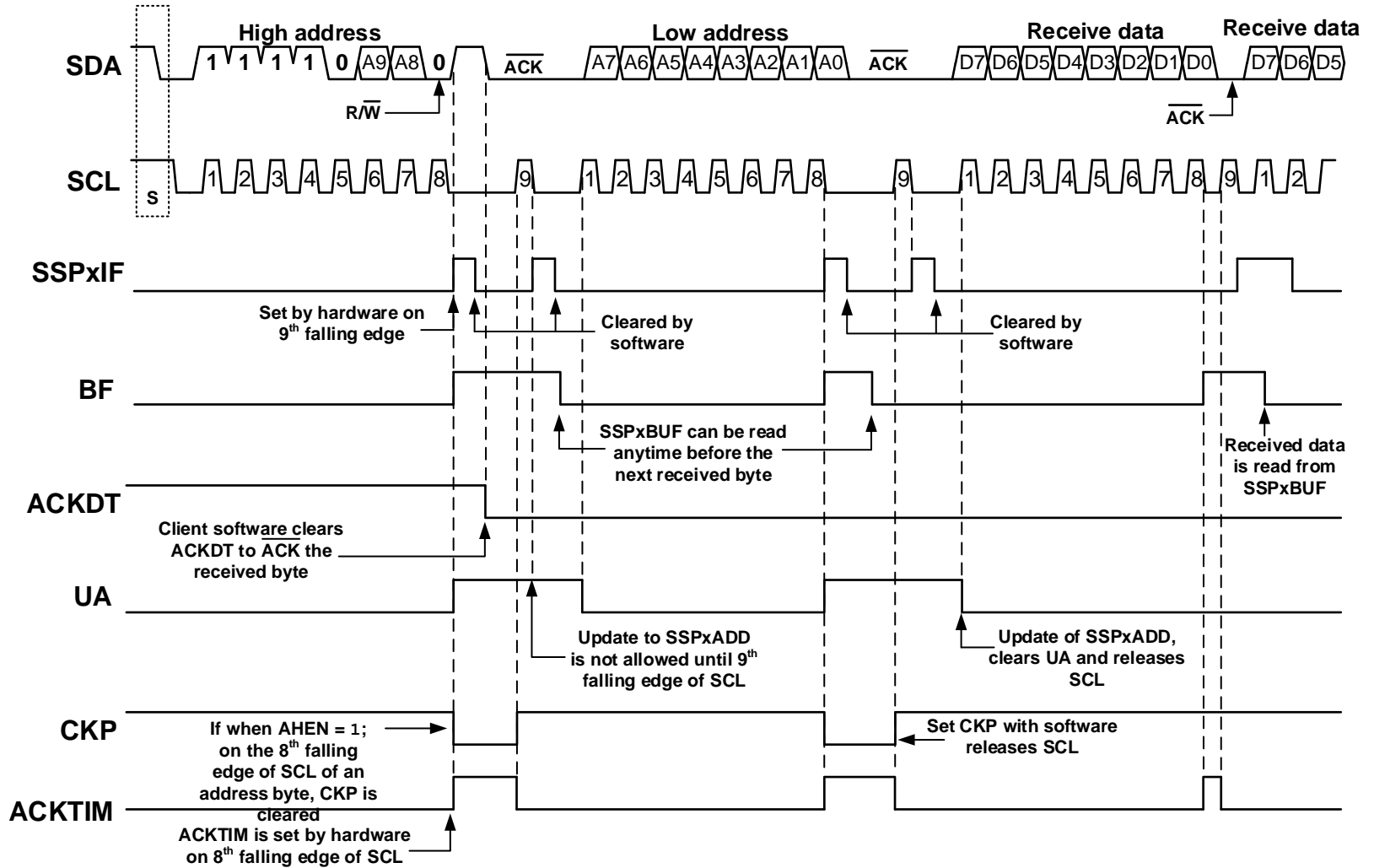
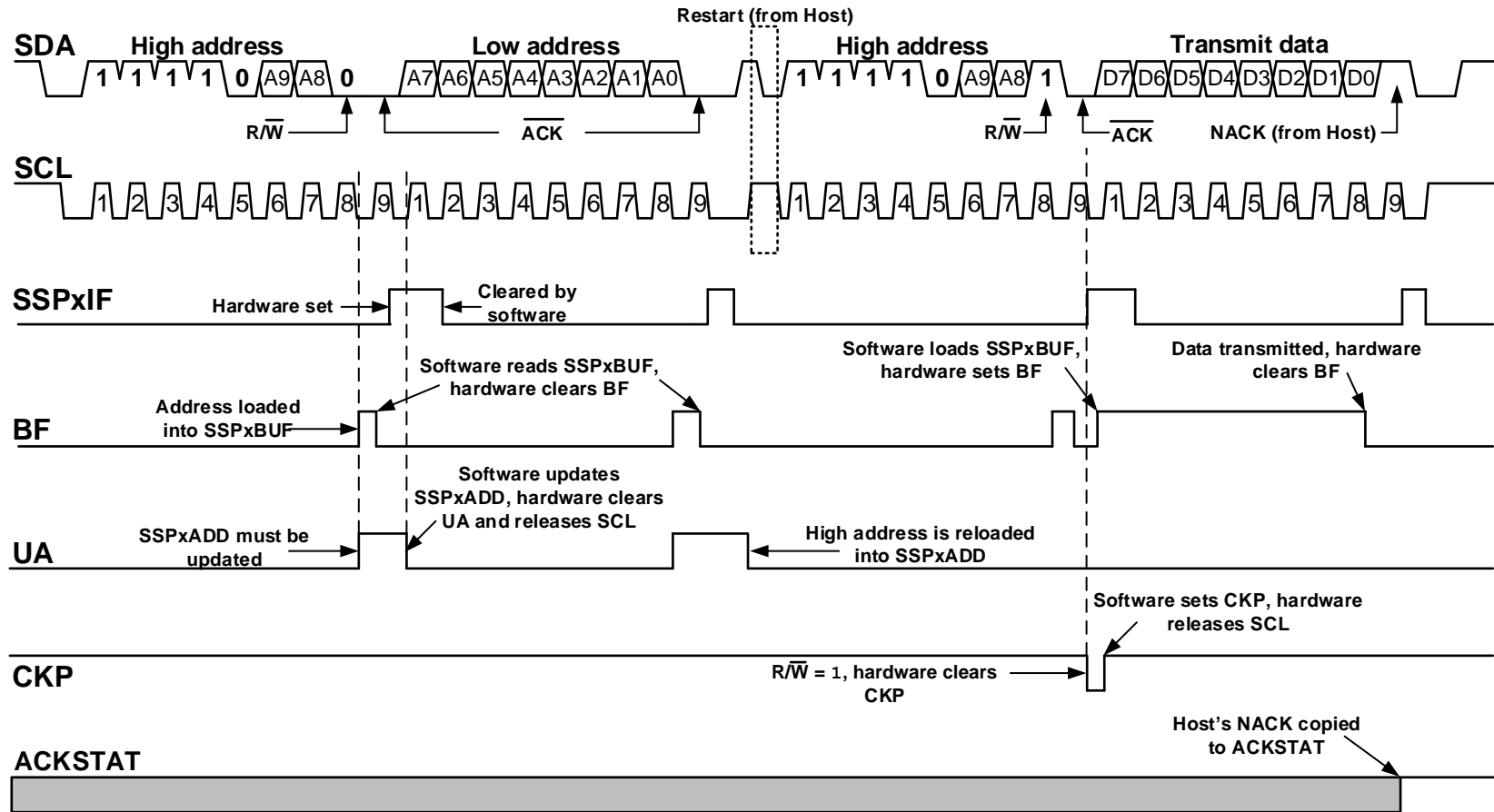

Figure 31-21. I²C Client, 10-Bit Address, Transmission (SEN = 0, AHEN = 0, DHEN = 0)



31.2.3.7 Client Transmission

When the R/\overline{W} bit of the incoming address byte is set and an address match occurs, the R/\overline{W} bit is set. The received address is loaded into the **SSPxBUF** register, and an \overline{ACK} pulse is sent by the client on the ninth bit.

Following the \overline{ACK} , client hardware clears the **CKP** bit and the SCL pin is held low (see [Clock Stretching](#) for more details). By stretching the clock, the host will be unable to assert another clock pulse until the client is done preparing the transmit data.

The transmit data must be loaded into the **SSPxBUF** register, which also loads the **SSPSR** register. Then the SCL pin will be released by setting the **CKP** bit. The eight data bits are shifted out on the falling edge of the SCL input. This ensures that the SDA signal is valid during the SCL high time.

The \overline{ACK} pulse from the host receiver is latched on the rising edge of the ninth SCL input pulse. This \overline{ACK} value is copied to the **ACKSTAT** bit. If **ACKSTAT** is set (NACK), then the data transfer is complete. In this case, when the NACK is latched by the client, the client goes Idle and waits for another occurrence of a Start condition. If the SDA line was low (\overline{ACK}), the next transmit data must be loaded into the **SSPxBUF** register. Again, the SCL pin must be released by setting bit **CKP**.

An MSSP interrupt is generated for each data transfer byte. The **SSPxIF** bit must be cleared by software and the **SSPxSTAT** register is used to determine the status of the byte. The **SSPxIF** bit is set on the falling edge of the ninth clock pulse.

31.2.3.7.1 Client Mode Bus Collision

A client receives a read request and begins shifting data out on the SDA line. If a bus collision is detected and the Client Mode Bus Collision Detect Enable (**SBCDE**) bit is set, the Bus Collision Interrupt Flag (**BCLxIF**) bit of the **PIRx** register is set. Once a bus collision is detected, the client goes Idle and waits to be addressed again. User software can use the **BCLxIF** bit to handle a client bus collision.

31.2.3.7.2 7-Bit Transmission

A host device can transmit a read request to a client and clock data out of the client. The list below outlines what software for a client will need to do to accomplish a standard transmission. [Figure 31-22](#) can be used as a reference to this list.

1. Host sends a Start condition.
2. The Start (**S**) bit is set; **SSPxIF** is set if **SCIE** is set.
3. Matching address with R/\overline{W} bit set is received by the Client, setting **SSPxIF** bit.
4. Client hardware generates an \overline{ACK} and sets **SSPxIF**.
5. The **SSPxIF** bit is cleared by software.
6. Software reads the received address from **SSPxBUF**, clearing **BF**.
7. R/\overline{W} is set so **CKP** was automatically cleared after the \overline{ACK} .
8. The client software loads the transmit data into **SSPxBUF**.
9. **CKP** bit is set by software, releasing SCL, allowing the host to clock the data out of the client.
10. **SSPxIF** is set after the \overline{ACK} response from the host is loaded into the **ACKSTAT** bit.
11. **SSPxIF** bit is cleared.
12. The client software checks the **ACKSTAT** bit to see if the host wants to clock out more data.



Important:

1. If the host \overline{ACK} s then the clock will be stretched.
2. **ACKSTAT** is the only bit updated on the rising edge of the ninth SCL clock instead of the falling edge.

13. Steps 9-13 are repeated for each transmitted byte.
14. If the host sends a not \overline{ACK} ; the clock is not held, but SSPxIF is still set.
15. The host sends a Restart condition or a Stop.

Figure 31-22. I²C Client, 7-Bit Address, Transmission (AHEN = 0)

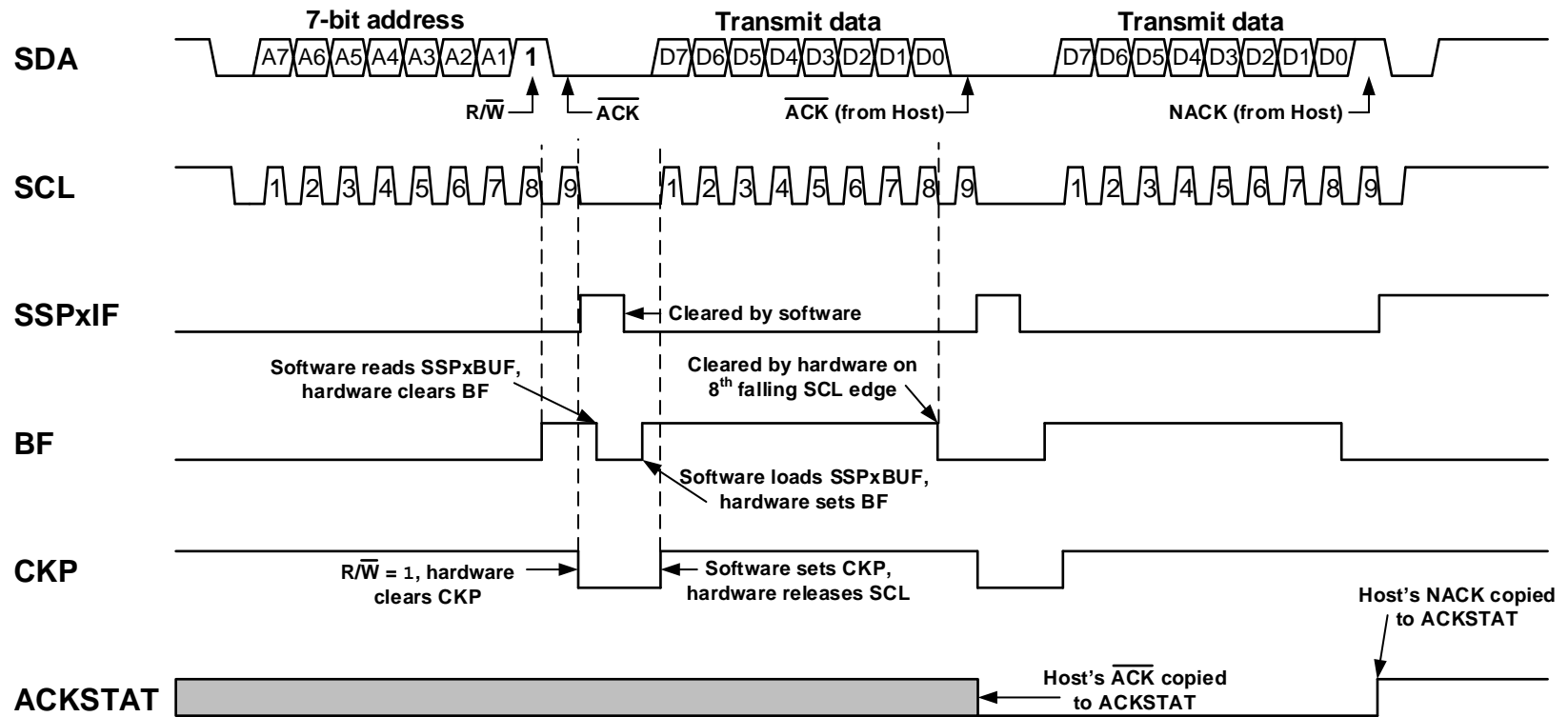

31.2.3.7.3 7-Bit Transmission with Address Hold Enabled

Setting the **AHEN** bit enables additional clock stretching and interrupt generation after the eighth falling edge of a received matching address. Once a matching address has been clocked in, **CKP** is cleared and the **SSPxIF** interrupt is set.

Figure 31-23 displays a standard waveform of a 7-bit address client transmission with **AHEN** enabled.

1. Bus starts Idle.
2. Host sends Start condition; the **S** bit is set; **SSPxIF** is set if **SCIE** is set.
3. Host sends matching address with the **R/W** bit set. After the eighth falling edge of the SCL line the **CKP** bit is cleared and **SSPxIF** interrupt is generated.
4. Client software clears **SSPxIF**.
5. Client software reads the **ACKTIM**, **R/W** and **D/A** bits to determine the source of the interrupt.
6. Client reads the address value from the **SSPxBUF** register, clearing the **BF** bit.
7. Client software decides from this information if it wishes to $\overline{\text{ACK}}$ or **NACK** and sets the **ACKDT** bit accordingly.
8. Client software sets the **CKP** bit, releasing SCL.
9. Host clocks in the $\overline{\text{ACK}}$ value from the client.
10. Client hardware automatically clears the **CKP** bit and sets **SSPxIF** after $\overline{\text{ACK}}$ if the **R/W** bit is set.
11. Client software clears **SSPxIF**.
12. Client loads value to transmit to the host into **SSPxBUF**, setting the **BF** bit.



Important: **SSPxBUF** cannot be loaded until after the $\overline{\text{ACK}}$.

13. Client software sets the **CKP** bit, releasing the clock.
14. Host clocks out the data from the client and sends an $\overline{\text{ACK}}$ value on the ninth SCL pulse.
15. Client hardware copies the $\overline{\text{ACK}}$ value into the **ACKSTAT** bit.
16. Steps 10-15 are repeated for each byte transmitted to the host from the client.
17. If the host sends a not $\overline{\text{ACK}}$, the client releases the bus allowing the host to send a Stop and end the communication.



Important: Host must send a not $\overline{\text{ACK}}$ on the last byte to ensure that the client releases the SCL line to receive a Stop.

Figure 31-23. I²C Client, 7-Bit Address, Transmission (AHEN = 1)

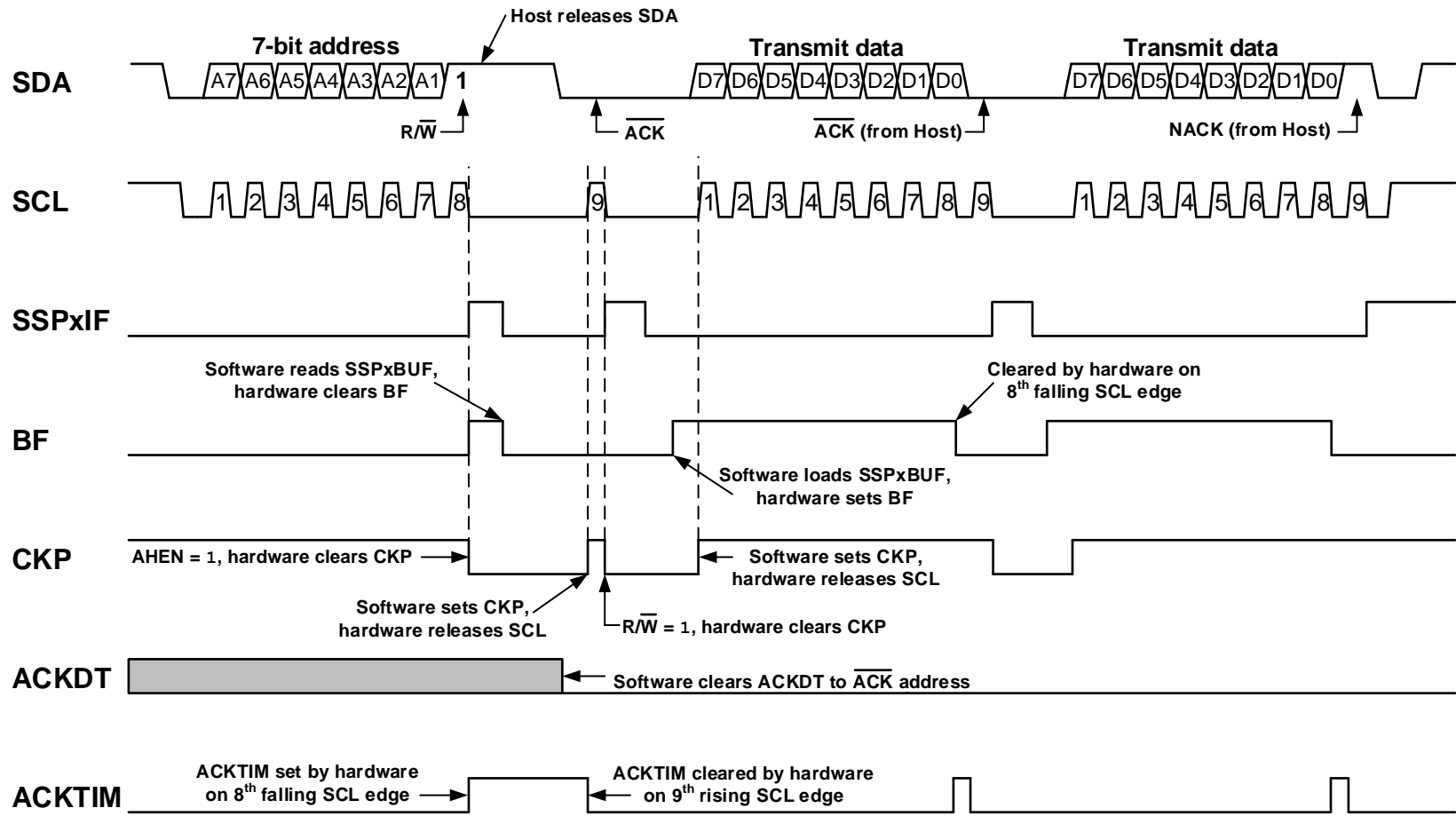

31.2.4 I²C Host Mode

Host mode is enabled by configuring the appropriate [SSPM](#) bits and setting the [SSPEN](#) bit. In Host mode, the SDA and SCL pins must be configured as inputs. The MSSP peripheral hardware will override the output driver TRIS controls when necessary to drive the pins low.

Host mode of operation is supported by interrupt generation on the detection of the Start and Stop conditions. The Stop ([P](#)) and Start ([S](#)) bits are cleared from a Reset or when the MSSP module is disabled. Control of the I²C bus may be taken when the P bit is set or when the bus is Idle.

In Firmware Controlled Host mode, user code conducts all I²C bus operations based on Start and Stop condition detection. Start and Stop condition detection is the only active circuitry in this mode. All other communication is done by the user software directly manipulating the SDA and SCL lines.

The following events will cause the MSSP Interrupt Flag ([SSPxIF](#)) bit to be set (MSSP interrupt, if enabled):

- Start condition detected
- Stop condition detected
- Data transfer byte transmitted/received
- Acknowledge transmitted/received
- Repeated Start generated



Important:

1. The MSSP module, when configured in I²C Host mode, does not allow queuing of events. For instance, the user is not allowed to initiate a Start condition and immediately write the [SSPxBUF](#) register to initiate transmission before the Start condition is complete. In this case, [SSPxBUF](#) will not be written to and the Write Collision Detect ([WCOL](#)) bit will be set, indicating that a write to [SSPxBUF](#) did not occur.
2. Host mode suspends Start/Stop detection when sending the Start/Stop condition by means of the [SEN/PEN](#) control bits. The [SSPxIF](#) bit is set at the end of the Start/Stop generation when hardware clears the control bit.

31.2.4.1 I²C Host Mode Operation

The host device generates all of the serial clock pulses and the Start and Stop conditions. A transfer is ended with a Stop condition or with a Repeated Start condition. Since the Repeated Start condition is also the beginning of the next serial transfer, the I²C bus will not be released.

In Host Transmitter mode, serial data are output through SDA, while SCL outputs the serial clock. The first byte transmitted contains the client address of the receiving device (seven bits) and the R/\overline{W} bit. In this case, the R/\overline{W} bit will be logic '0'. Serial data are transmitted eight bits at a time. After each byte is transmitted, an Acknowledge bit is received. Start and Stop conditions are output to indicate the beginning and the end of a serial transfer.

In Host Receive mode, the first byte transmitted contains the client address of the transmitting device (seven bits) and the R/\overline{W} bit. In this case, the R/\overline{W} bit will be logic '1'. Thus, the first byte transmitted is a 7-bit client address followed by a '1' to indicate the receive bit. Serial data are received via SDA, while SCL outputs the serial clock. Serial data are received eight bits at a time. After each byte is received, an Acknowledge sequence is transmitted. Start and Stop conditions indicate the beginning and end of transmission.

A Baud Rate Generator is used to set the clock frequency output on SCL. See [Baud Rate Generator](#) for more details.

31.2.4.1.1 Clock Arbitration

Clock arbitration occurs when the host, during any receive, transmit or Repeated Start/Stop condition, releases the SCL pin (SCL allowed to float high). When the SCL pin is allowed to float high, the Baud Rate Generator (BRG) is suspended from counting until the SCL pin is actually sampled high. When the SCL pin is sampled high, the Baud Rate Generator is reloaded with the contents of [SSPxADD](#) and begins counting. This ensures that the SCL high time will always be at least one BRG rollover count in the event that the clock is held low by an external device as shown in [Figure 31-24](#).

Figure 31-24. Baud Rate Generator Timing with Clock Arbitration

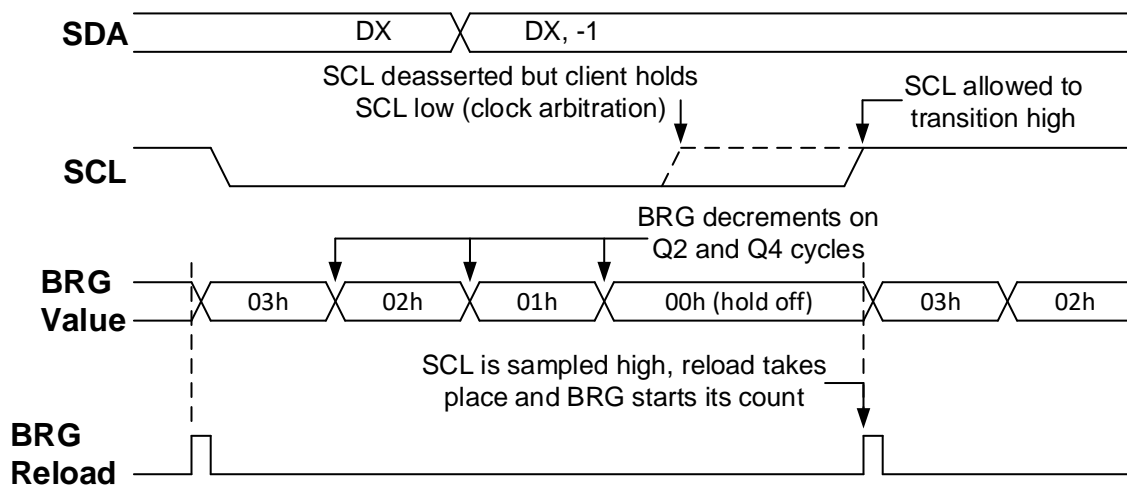

31.2.4.1.2 WCOL Status Flag

If the user writes the [SSPxBUF](#) when a Start, Restart, Stop, Receive or Transmit sequence is in progress, the Write Collision Detect ([WCOL](#)) bit is set and the contents of the buffer are unchanged (the write does not occur). Any time the [WCOL](#) bit is set it indicates that an action on [SSPxBUF](#) was attempted while the module was not Idle.



Important: Because queuing of events is not allowed, writing to the lower five bits of [SSPxCON2](#) is disabled until the Start condition is complete.

31.2.4.1.3 I²C Host Mode Start Condition Timing

To initiate a Start condition (see [Figure 31-25](#)), the user sets the Start Condition Enable ([SEN](#)) bit. If the SDA and SCL pins are sampled high, the Baud Rate Generator is reloaded with the contents of [SSPxADD](#) and starts its count. If SCL and SDA are both sampled high when the Baud Rate Generator times out (T_{BRG}), the SDA pin is driven low. The action of the SDA being driven low while SCL is high is the Start condition and causes the Start ([S](#)) bit to be set. Following this, the Baud Rate Generator is reloaded with the contents of [SSPxADD](#) and resumes its count. When the Baud Rate Generator times out (T_{BRG}), the [SEN](#) bit will be automatically cleared by hardware; the Baud Rate Generator is suspended, leaving the SDA line held low and the Start condition is complete.

**Important:**

1. If at the beginning of the Start condition, the SDA and SCL pins are already sampled low, or if during the Start condition, the SCL line is sampled low before the SDA line is driven low, a bus collision occurs, the Bus Collision Interrupt Flag (BCLxIF) is set, the Start condition is aborted, and the I²C module is reset into its Idle state.
2. The Philips I²C Specification states that a bus collision cannot occur on a Start.

Figure 31-25. First Start Bit Timing

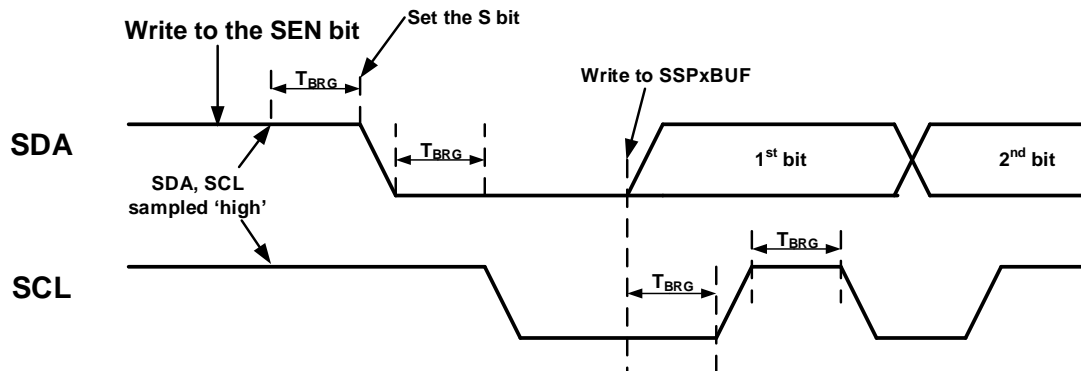

31.2.4.1.4 I²C Host Mode Repeated Start Condition Timing

A Repeated Start condition (see [Figure 31-26](#)) occurs when the Repeated Start Condition Enable (**RSEN**) bit is programmed high and the host state machine is Idle. When the RSEN bit is set, the SCL pin is asserted low. When the SCL pin is sampled low, the Baud Rate Generator is loaded and begins counting. The SDA pin is released (brought high) for one Baud Rate Generator count (T_{BRG}). When the Baud Rate Generator times out, if SDA is sampled high, the SCL pin will be deasserted (brought high). When SCL is sampled high, the Baud Rate Generator is reloaded and begins counting. SDA and SCL must remain high for one T_{BRG} . Module hardware then pulls the SDA line low (while SCL remains high) for one T_{BRG} and then pulls the SCL line low. Following this, the RSEN bit will be automatically cleared and the Baud Rate Generator will not be reloaded, leaving the SDA pin held low. As soon as a Start condition is detected on the SDA and SCL pins, the **S** bit will be set. The SSPxIF bit will not be set until the Baud Rate Generator has timed out.

**Important:**

1. If RSEN is programmed while any other event is in progress, it will not take effect.
2. A bus collision during the Repeated Start condition occurs if:
 - SDA is sampled low when SCL goes from low-to-high.
 - SCL goes low before SDA is asserted low. This may indicate that another host is attempting to transmit a data '1'.

Figure 31-26. Repeated Start Condition Waveform

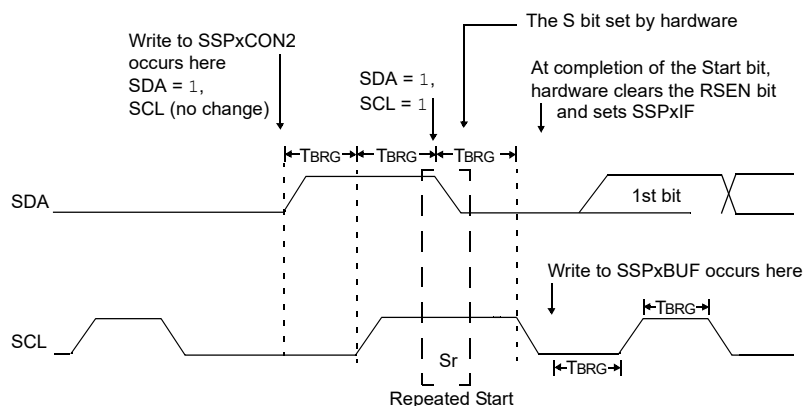
Rev. 30-000037B
4/10/2017

31.2.4.1.5 Acknowledge Sequence Timing

An Acknowledge sequence (see Figure 31-27) is enabled by setting the Acknowledge Sequence Enable (**ACKEN**) bit. When this bit is set, the SCL pin is pulled low and the contents of the Acknowledge Data (**ACKDT**) bit are presented on the SDA pin. If the user wishes to generate an Acknowledge, then the **ACKDT** bit must be cleared. If not, the user must set the **ACKDT** bit before starting an Acknowledge sequence. The Baud Rate Generator then counts for one rollover period (T_{BRG}) and the SCL pin is deasserted (pulled high). When the SCL pin is sampled high (clock arbitration), the Baud Rate Generator counts for T_{BRG} . The SCL pin is then pulled low. Following this, the **ACKEN** bit is automatically cleared, the Baud Rate Generator is turned off and the MSSP module then goes into Idle mode.

Figure 31-27. Acknowledge Sequence Waveform

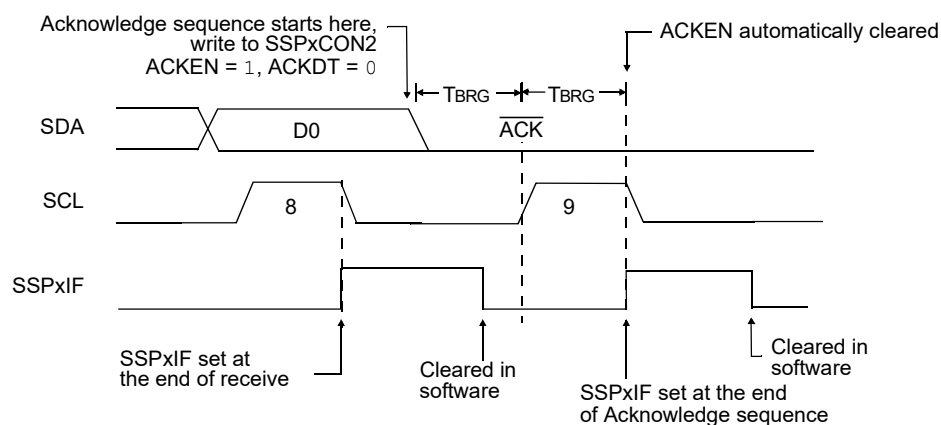
Rev. 30-000040A
4/3/2017

Note: T_{BRG} = one Baud Rate Generator period.

Acknowledge Write Collision

If the user writes the **SSPxBUF** when an Acknowledge sequence is in progress, then the **WCOL** bit is set and the contents of the buffer are unchanged (the write does not occur).

31.2.4.1.6 Stop Condition Timing

A Stop condition (see Figure 31-28) is asserted on the SDA pin at the end of a receive/transmit by setting the Stop Condition Enable (**PEN**) bit. At the end of a receive/transmit, the SCL line is held low after the falling edge of the ninth clock. When the **PEN** bit is set, the host will assert the SDA line low. When the SDA line is sampled low, the Baud Rate Generator is reloaded and counts down to '0'.

When the Baud Rate Generator times out, the SCL pin will be brought high and one T_{BRG} (Baud Rate Generator rollover count) later, the SDA pin will be deasserted. When the SDA pin is sampled high while SCL is high, the P bit is set. One T_{BRG} later, the PEN bit is cleared and the SSPxIF bit is set.

Figure 31-28. Stop Condition in Receive or Transmit Mode

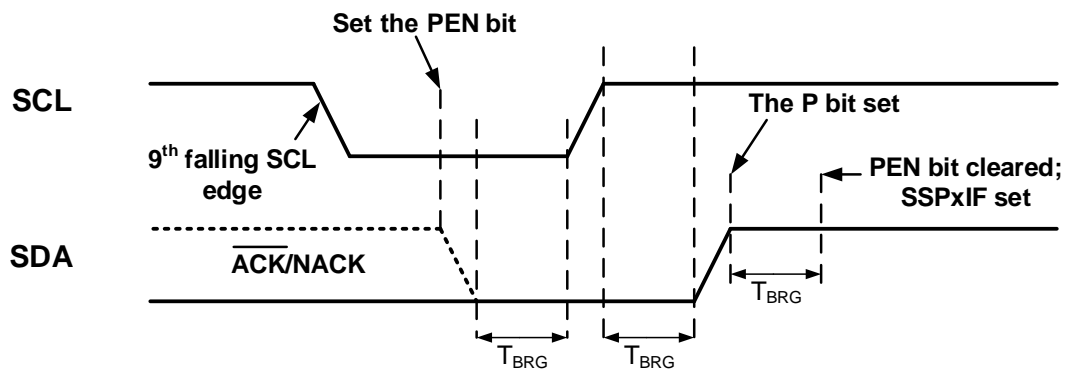

Write Collision on Stop

If the user writes the `SSPxBUF` when a Stop sequence is in progress, then the `WCOL` bit is set and the contents of the buffer are unchanged (the write does not occur).

31.2.4.1.7 Sleep Operation

While in Sleep mode, the I²C client module can receive addresses or data and when an address match or complete byte transfer occurs, wake the processor from Sleep (if the MSSP interrupt is enabled).

31.2.4.1.8 Effects of a Reset

A Reset disables the MSSP module and terminates the current transfer.

31.2.4.2 I²C Host Mode Transmission

Transmission of a data byte, a 7-bit address or the other half of a 10-bit address is accomplished by simply writing a value to the `SSPxBUF` register. This action will set the Buffer Full Status (`BF`) bit and allow the Baud Rate Generator to begin counting and start the next transmission.

Each bit of address/data will be shifted out onto the SDA pin after the falling edge of SCL is asserted. SCL is held low for one Baud Rate Generator rollover count (T_{BRG}). Data must be valid before SCL is released high. When the SCL pin is released high, it is held that way for T_{BRG} . The data on the SDA pin must remain stable for that duration and some hold time after the next falling edge of SCL. After the eighth bit is shifted out (the falling edge of the eighth clock), the `BF` flag is cleared and the host releases SDA. This allows the client device being addressed to respond with an \overline{ACK} sequence during the ninth bit time if an address match occurred or if data was received properly. The status of \overline{ACK} is written into the Acknowledge Status (`ACKSTAT`) bit on the rising edge of the ninth clock. If the host receives an \overline{ACK} , the `ACKSTAT` bit is cleared. If a NACK is received, `ACKSTAT` is set. After the ninth clock, the `SSPxIF` bit is set and the host clock (Baud Rate Generator) is suspended until the next data byte is loaded into the `SSPxBUF`, leaving SCL low and SDA unchanged (see Figure 31-29).

After the write to the `SSPxBUF`, each bit of the address will be shifted out on the falling edge of SCL until all seven address bits and the `R/W` bit are completed. On the falling edge of the eighth clock, the host will release the SDA pin, allowing the client to respond with an \overline{ACK} . On the falling edge of the ninth clock, the host will sample the SDA pin to see if the address was recognized by a client. The status of the \overline{ACK} bit is loaded into the `ACKSTAT` bit.

Following the falling edge of the ninth clock transmission of the address, the SSPxIF is set, the BF flag is cleared and the Baud Rate Generator is turned off until another write to the SSPxBUF takes place, holding SCL low and allowing SDA to float.

31.2.4.2.1 BF Status Flag

In Transmit mode, the Buffer Full Status (BF) bit is set when the CPU writes to SSPxBUF and is cleared when all eight bits are shifted out.

31.2.4.2.2 WCOL Status Flag

If the user writes the SSPxBUF when a transmit is already in progress (i.e., SSPSR is still shifting out a data byte), the Write Collision Detect (WCOL) bit is set and the contents of the buffer are unchanged (the write does not occur).

The WCOL bit must be cleared by software before the next transmission.

31.2.4.2.3 ACKSTAT Status Flag

In Transmit mode, the Acknowledge Status (ACKSTAT) bit is cleared when the client has sent an Acknowledge ($\overline{\text{ACK}} = 0$) and is set when the client issues a NACK. A client sends an $\overline{\text{ACK}}$ when it has recognized its address (including a General Call) or when the client has properly received its data.

31.2.4.2.4 Typical Transmit Sequence

1. The Host generates a Start condition by setting the SEN bit.
2. SSPxIF is set by hardware on completion of the Start.
3. SSPxIF is cleared by software.
4. The MSSP module will wait the required start time before any other operation takes place.
5. Software loads the SSPxBUF with the client address and the R/W bit. In Host Transmit mode, the R/W value is zero.
6. Address is shifted out the SDA pin until all eight bits are transmitted. Transmission begins as soon as SSPxBUF is written to.
7. The MSSP module shifts in the $\overline{\text{ACK}}$ value from the client device and writes its into the ACKSTAT bit.
8. The MSSP module generates an interrupt at the end of the ninth clock cycle by setting the SSPxIF bit.
9. Software loads the SSPxBUF with eight bits of data.
10. Data shift out the SDA pin until all eight bits are transmitted.
11. The MSSP module shifts in the $\overline{\text{ACK}}$ bit from the client device and writes its value into the ACKSTAT bit.
12. Steps 8-11 are repeated for all transmitted data bytes.
13. The user generates a Stop or Restart condition by setting the PEN or RSEN bits, respectively. An Interrupt is generated once the Stop/Restart condition is complete.

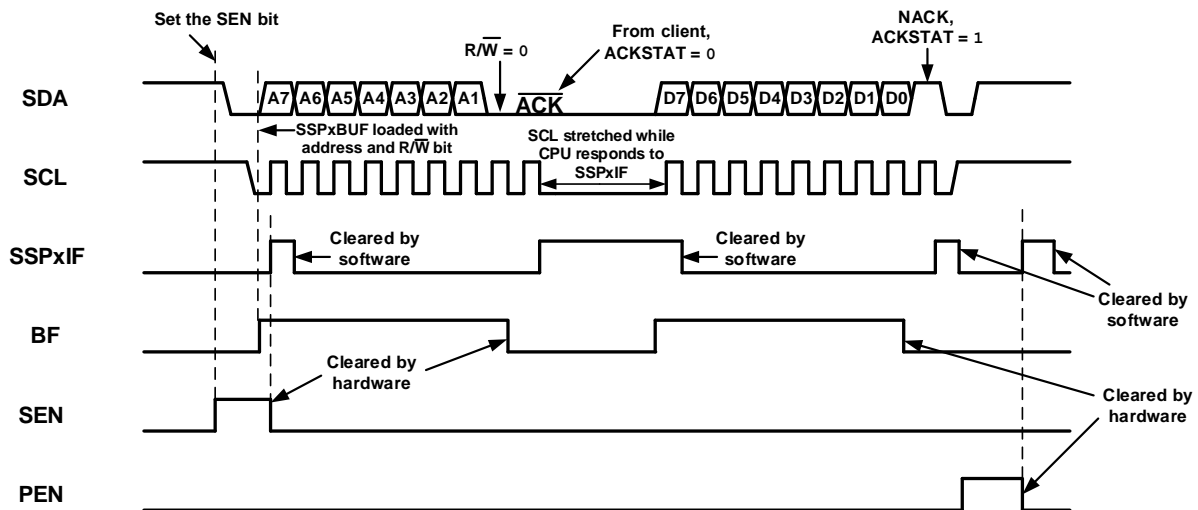
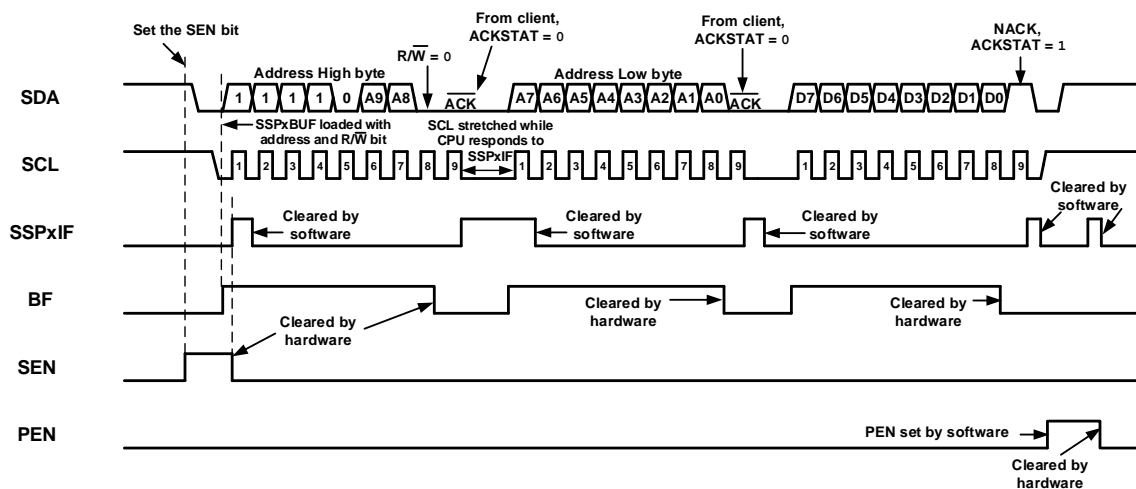
Figure 31-29. I²C Host Mode Waveform (Transmission, 7-Bit Address)Figure 31-30. I²C Host Mode Waveform (Transmission, 10-Bit Address)

31.2.4.3 I²C Host Mode Reception

Host mode reception (see Figure 31-31) is enabled by setting the Receive Enable (RCEN) bit.



Important: The MSSP module must be in an Idle state before the RCEN bit is set or the RCEN bit will be disregarded.

The Baud Rate Generator begins counting and on each rollover, the state of the SCL pin changes (high-to-low/low-to-high) and data are shifted into the SSPxSR. After the falling edge of the eighth clock all the following events occur:

- RCEN is automatically cleared by hardware.

- The contents of the SSPxSR are loaded into the SSPxBUF.
- The BF flag bit is set.
- The SSPxIF flag bit is set.
- The Baud Rate Generator is suspended from counting.
- The SCL pin is held low.

The MSSP is now in Idle state awaiting the next command. When the buffer is read by the CPU, the BF flag bit is automatically cleared. The Host can then send an Acknowledge sequence at the end of reception by setting the Acknowledge Sequence Enable (ACKEN) bit.

31.2.4.3.1 BF Status Flag

In receive operation, the BF bit is set when an address or data byte is loaded into SSPxBUF from SSPSR. It is cleared when the SSPxBUF register is read.

31.2.4.3.2 SSPOV Status Flag

In receive operation, the SSPOV bit is set when eight bits are received into SSPxSR while the BF flag bit is already set from a previous reception.

31.2.4.3.3 WCOL Status Flag

If the user writes the SSPxBUF when a receive is already in progress (i.e., SSPxSR is still shifting in a data byte), the WCOL bit is set and the contents of the buffer are unchanged (the write does not occur).

31.2.4.3.4 Typical Receive Sequence

1. The Host generates a Start condition by setting the **SEN** bit.
2. **SSPxIF** is set by hardware on completion of the Start.
3. **SSPxIF** is cleared by software.
4. Software writes **SSPxBUF** with the client address to transmit and the R/\bar{W} bit set.
5. Address is shifted out the SDA pin until all eight bits are transmitted. Transmission begins as soon as **SSPxBUF** is written to.
6. The MSSP module shifts in the \bar{ACK} value from the client device and writes it into the **ACKSTAT** bit.
7. The MSSP module generates an interrupt at the end of the ninth clock cycle by setting the **SSPxIF** bit.
8. Software sets the **RCEN** bit and the host clocks in a byte from the client.
9. After the eighth falling edge of SCL, **SSPxIF** and **BF** are set.
10. Host clears **SSPxIF** and reads the received byte from **SSPxBUF**, which clears **BF**.
11. Host clears the **ACKDT** bit and initiates the \bar{ACK} sequence by setting the **ACKEN** bit.
12. Host's \bar{ACK} is clocked out to the client and **SSPxIF** is set.
13. User clears **SSPxIF**.
14. Steps 8-13 are repeated for each received byte from the client.
15. Host sends a NACK or Stop to end communication.

Figure 31-31. I²C Host Mode Waveform (Reception, 7-Bit Address)

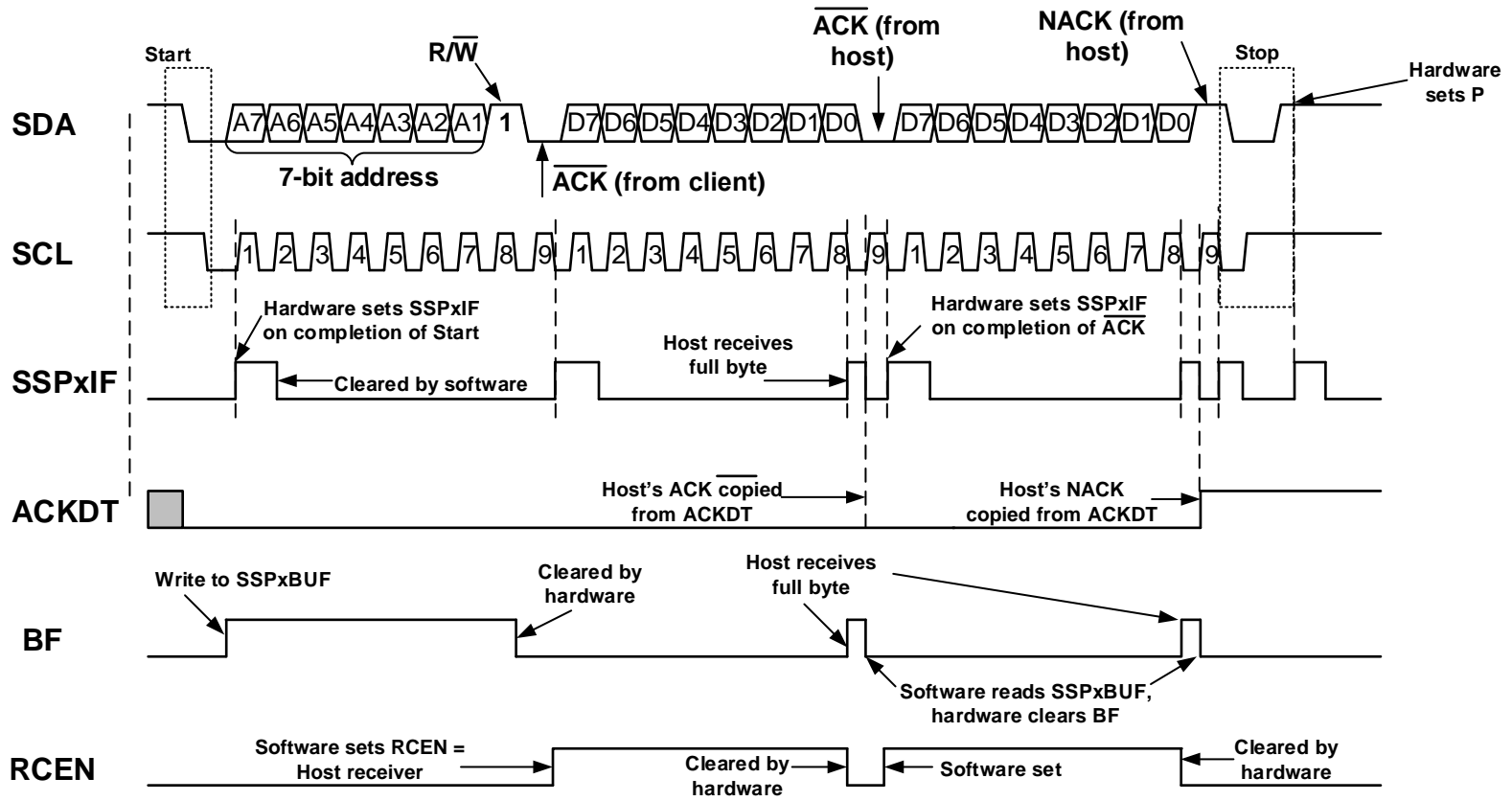
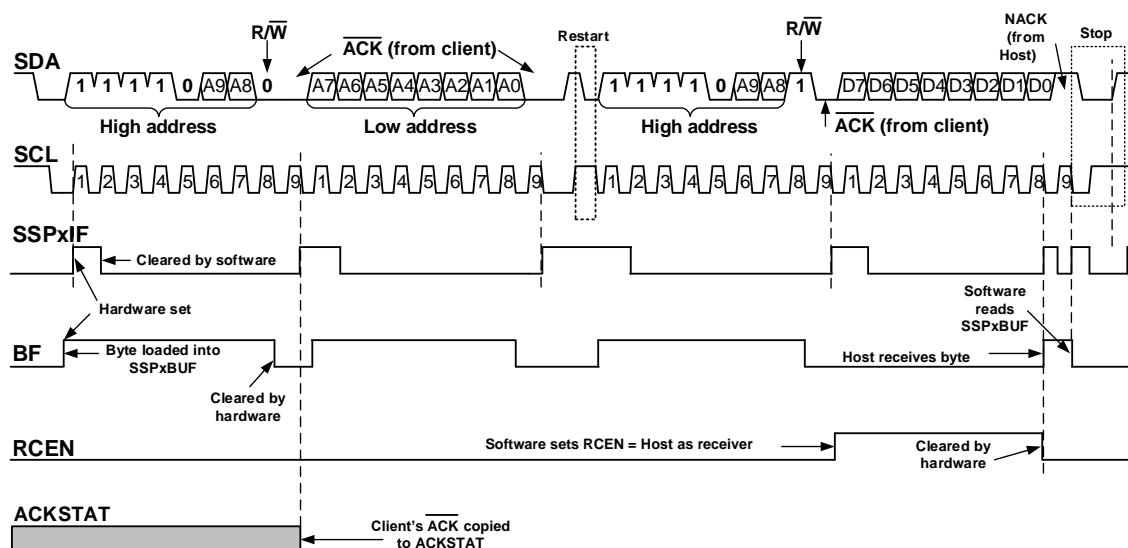

Figure 31-32. I²C Host Mode Waveform (Reception, 10-Bit Address)

31.2.5 Multi-Host Mode

In Multi-Host mode, the interrupt generation on the detection of the Start and Stop conditions allows the determination of when the bus is free. The Stop (P) and Start (S) bits are cleared from a Reset or when the MSSP module is disabled. Control of the I²C bus may be taken when the P bit is set or when the bus is Idle, with both the S and P bits cleared. When the bus is busy, enabling the MSSP interrupt will generate an interrupt when the Stop condition occurs.

In Multi-Host operation, the SDA line must be monitored for arbitration to see if the signal level is the expected output level. This check is performed by hardware with the result placed in the BCLxIF bit.

The states where arbitration can be lost are:

- Address Transfer
- Data Transfer
- A Start Condition
- A Repeated Start Condition
- An Acknowledge Condition

31.2.5.1 Multi-Host Communication, Bus Collision and Bus Arbitration

Multi-Host mode support is achieved by bus arbitration. When the host outputs address/data bits onto the SDA pin, arbitration takes place when the host outputs a '1' on SDA, by letting SDA float high and another host asserts a '0'. When the SCL pin floats high, data may be stable. If the expected data on SDA is a '1' and the data sampled on the SDA pin is '0', then a bus collision has taken place. The host will set the Bus Collision Interrupt Flag (BCLxIF) and reset the I²C port to its Idle state (see Figure 31-33).

If a transmit was in progress when the bus collision occurred, the transmission is halted, the BF flag is cleared, the SDA and SCL lines are deasserted, and the SSPxBUF can be written to. When software services the bus collision Interrupt Service Routine, and if the I²C bus is free, software can resume communication by asserting a Start condition.

If a Start, Repeated Start, Stop or Acknowledge condition was in progress when the bus collision occurred, the condition is aborted, the SDA and SCL lines are deasserted, and the respective control bits in the `SSPxCON2` register are cleared. When software services the bus collision Interrupt Service Routine, and if the I²C bus is free, software can resume communication by asserting a Start condition.

The host will continue to monitor the SDA and SCL pins. If a Stop condition occurs, the `SSPxIF` bit will be set.

A write to the `SSPxBUF` will start the transmission of data at the first data bit, regardless of where the transmitter left off when the bus collision occurred.

In Multi-Host mode, the interrupt generation on the detection of Start and Stop conditions allows the determination of when the bus is free. Control of the I²C bus can be taken when the `P` bit is set or when the bus is Idle and the `S` and `P` bits are cleared.

Figure 31-33. Bus Collision Timing for Transmit and Acknowledge

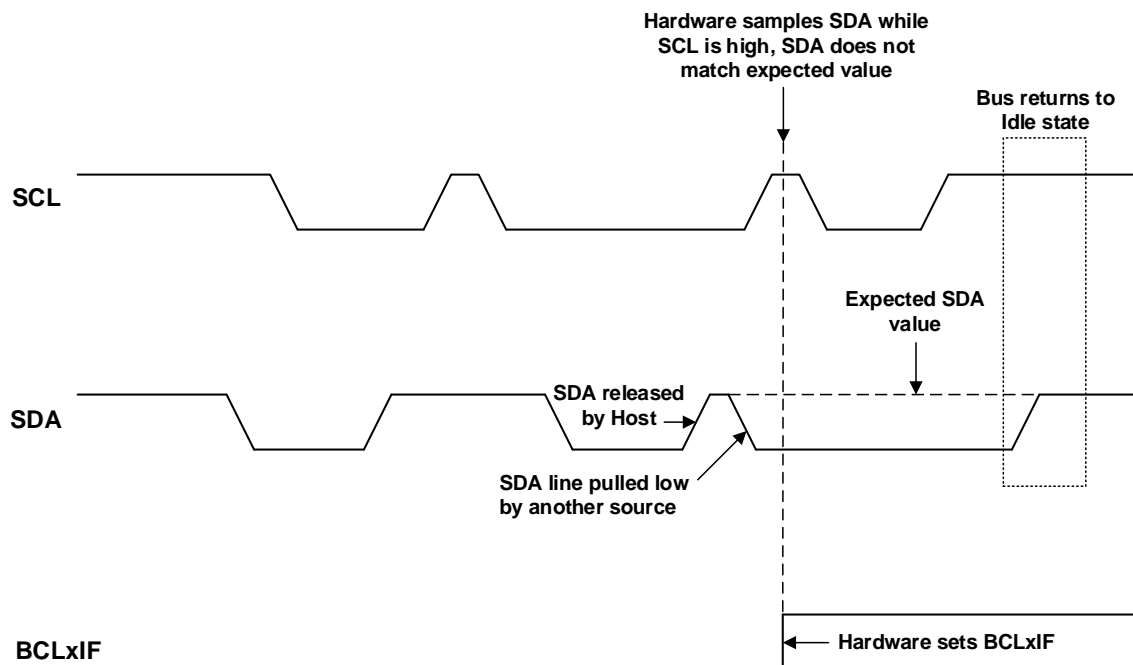

31.2.5.1.1 Bus Collision During a Start Condition

During a Start condition, a bus collision occurs if:

1. SDA or SCL are sampled low at the beginning of the Start condition (see [Figure 31-34](#)).
2. SCL is sampled low before SDA is asserted low (see [Figure 31-35](#)).

During a Start condition, both the SDA and the SCL pins are monitored.

If either the SDA pin or the SCL pin is already low, then all of the following occur:

- the Start condition is aborted,
- the `BCLxIF` flag is set, and
- the MSSP module is reset to its Idle state (see [Figure 31-34](#)).

Figure 31-34. Bus Collision During Start Condition (SDA Only)

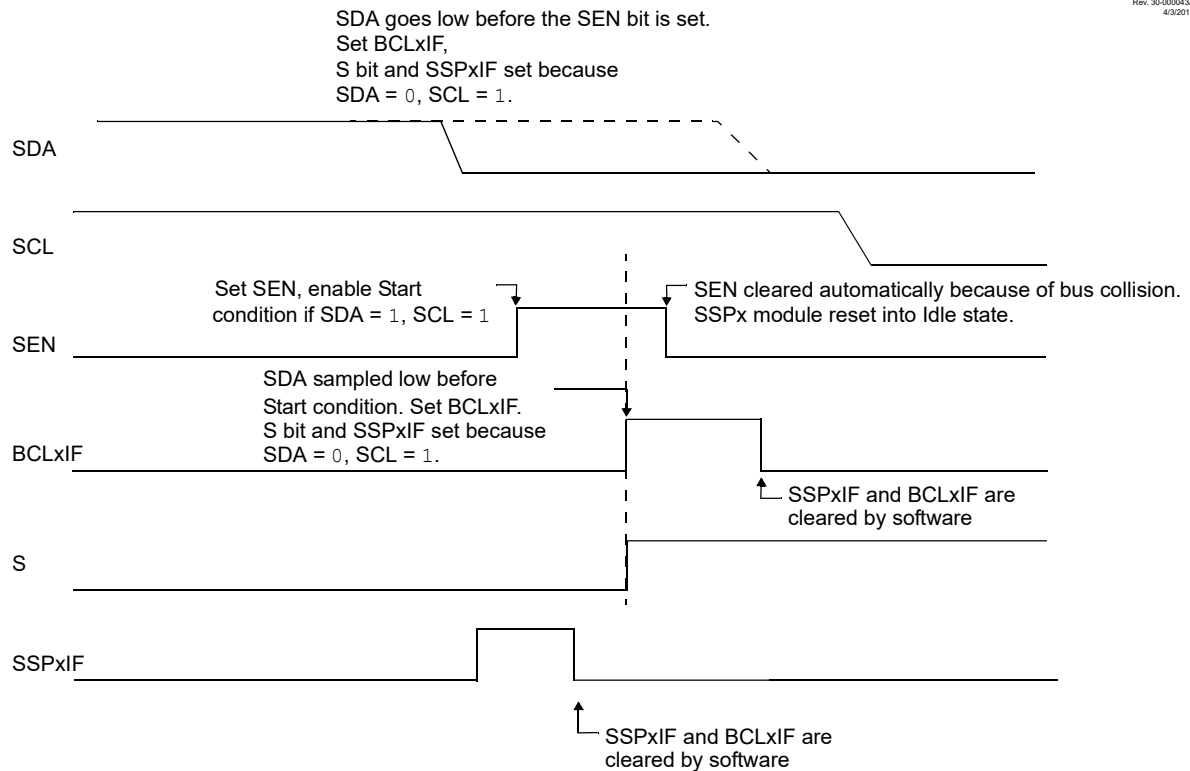

Rev. 30-000043A
4/3/2017

The Start condition begins with the SDA and SCL pins deasserted. When the SDA pin is sampled high, the Baud Rate Generator is loaded and counts down. If the SCL pin is sampled low while SDA is high, a bus collision occurs because it is assumed that another host is attempting to drive a data '1' during the Start condition.

Figure 31-35. Bus Collision During Start Condition (SCL = 0)

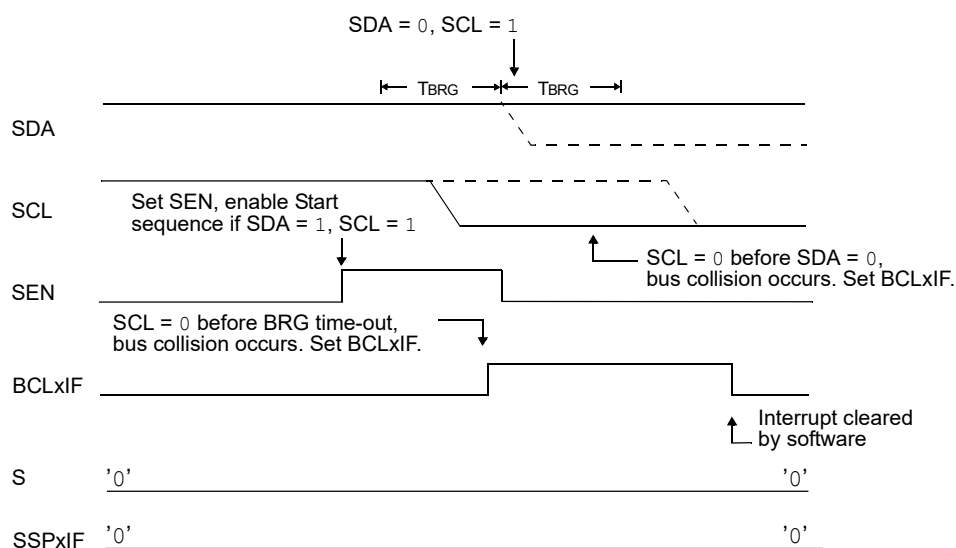

Rev. 30-000044A
4/3/2017

If the SDA pin is sampled low during this count, the BRG is reset and the SDA line is asserted early (see Figure 31-36). If, however, a '1' is sampled on the SDA pin, the SDA pin is asserted low at the end of the BRG count. The Baud Rate Generator is then reloaded and counts down to zero; if the SCL pin is sampled as '0' during this time, a bus collision does not occur. At the end of the BRG count, the SCL pin is asserted low.

Figure 31-36. BRG Reset Due to SDA Arbitration During Start Condition

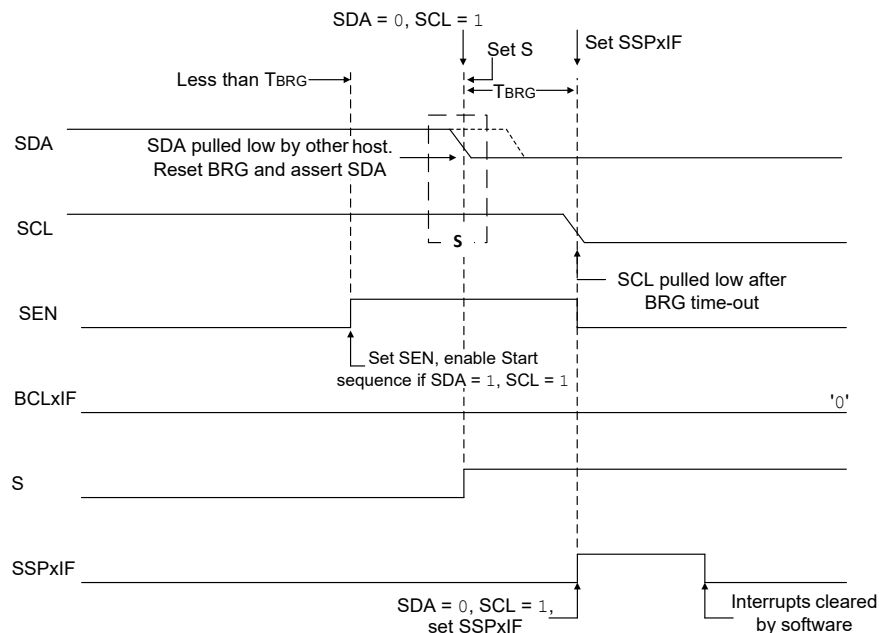

Important: The reason that a bus collision is not a factor during a Start condition is that no two bus hosts can assert a Start condition at the exact same time. Therefore, one host will always assert SDA before the other. This condition does not cause a bus collision because the two hosts must be allowed to arbitrate the first address following the Start condition. If the address is the same, arbitration must be allowed to continue into the data portion, Repeated Start or Stop conditions.

31.2.5.1.2 Bus Collision During a Repeated Start Condition

During a Repeated Start condition, a bus collision occurs if:

1. A low level is sampled on SDA when SCL goes from low level to high level (see Figure 31-37).
2. SCL goes low before SDA is asserted low, indicating that another host is attempting to transmit a data '1' (see Figure 31-38).

When the user releases SDA and the pin is allowed to float high, the BRG is loaded with $SSPxADD$ and counts down to zero. The SCL pin is then deasserted and when sampled high, the SDA pin is sampled.

If SDA is low, a bus collision has occurred (i.e., another host is attempting to transmit a data '0', see [Figure 31-37](#)). If SDA is sampled high, the BRG is reloaded and begins counting. If SDA goes from high-to-low before the BRG times out, no bus collision occurs because no two hosts can assert SDA at exactly the same time.

Figure 31-37. Bus Collision During a Repeated Start Condition (Case 1)



If SCL goes from high-to-low before the BRG times out and SDA has not already been asserted, a bus collision occurs. In this case, another host is attempting to transmit a data '1' during the Repeated Start condition (see [Figure 31-38](#)).

If, at the end of the BRG time-out, both SCL and SDA are still high, the SDA pin is driven low and the BRG is reloaded and begins counting. At the end of the count, regardless of the status of the SCL pin, the SCL pin is driven low and the Repeated Start condition is complete.

Figure 31-38. Bus Collision During Repeated Start Condition (Case 2)

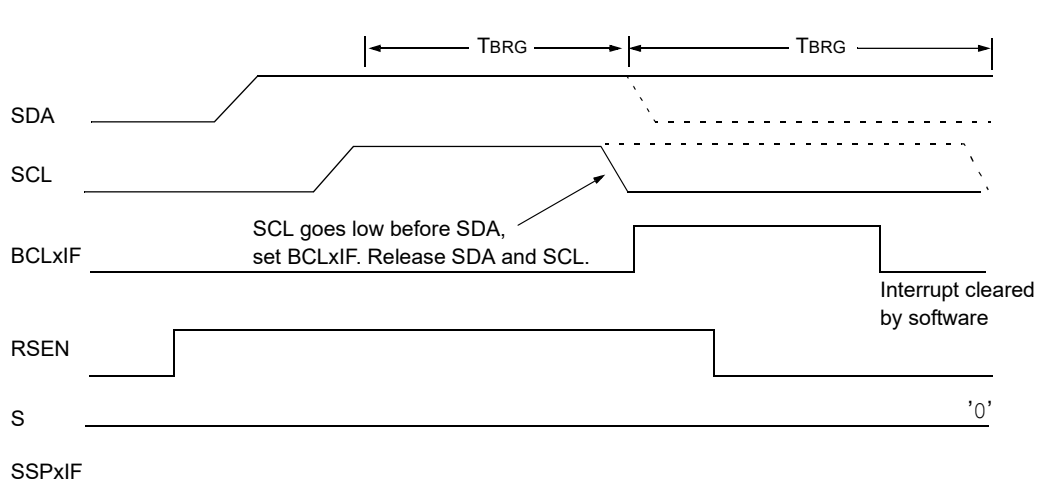

31.2.5.1.3 Bus Collision During a Stop Condition

Bus collision occurs during a Stop condition if:

1. After the SDA pin has been deasserted and allowed to float high, SDA is sampled low after the BRG has timed out (see Figure 31-39).
2. After the SCL pin is deasserted, SCL is sampled low before SDA goes high (see Figure 31-40).

The Stop condition begins with SDA asserted low. When SDA is sampled low, the SCL pin is allowed to float. When the pin is sampled high (clock arbitration), the Baud Rate Generator is loaded with `SSPxADD` and counts down to zero. After the BRG times out, SDA is sampled. If SDA is sampled low, a bus collision has occurred. This is due to another host attempting to drive a data '0' (see Figure 31-39). If the SCL pin is sampled low before SDA is allowed to float high, a bus collision occurs. This is another case of another host attempting to drive a data '0' (Figure 31-40).

Figure 31-39. Bus Collision During a Stop Condition (Case 1)

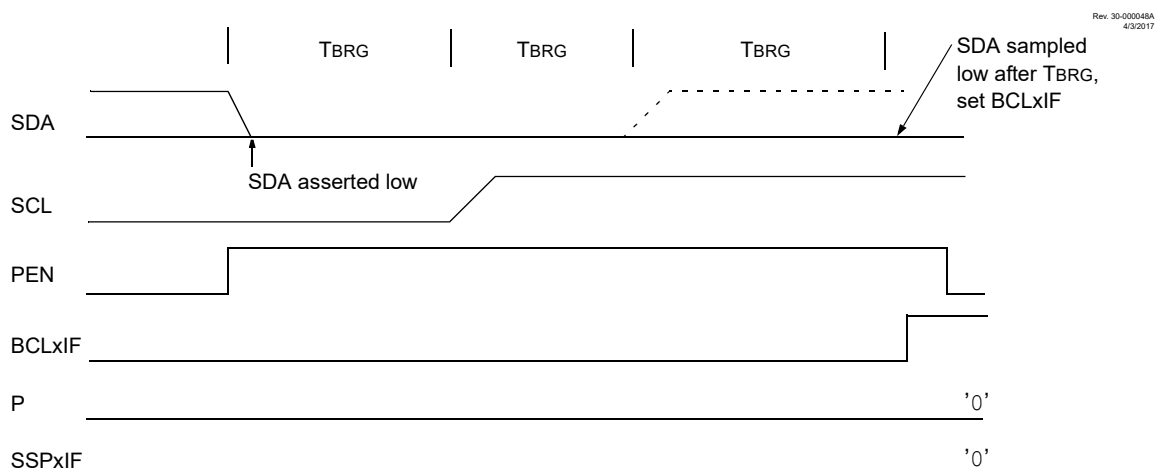
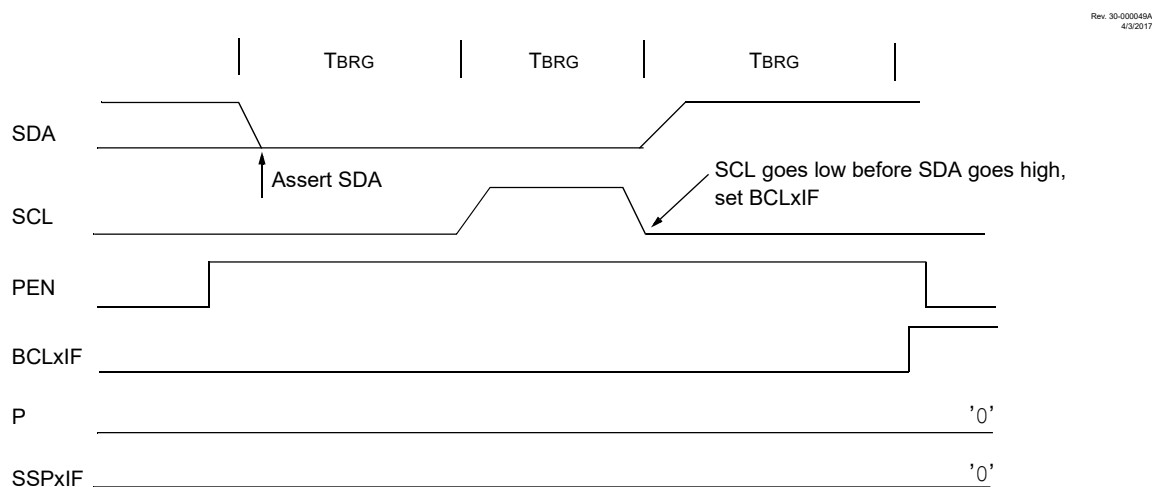

Figure 31-40. Bus Collision During a Stop Condition (Case 2)



31.3 Baud Rate Generator

The MSSP module has a Baud Rate Generator (BRG) available for clock generation in both I²C and SPI Host modes. The BRG reload value is placed in the `SSPxADD` register. When a write occurs to

SSPxBUF, the BRG will automatically begin counting down. [Example 31-1](#) shows how the value for **SSPxADD** is calculated.

Once the given operation is complete, the internal clock will automatically stop counting and the clock pin will remain in its last state.

An internal Reload signal, shown in [Figure 31-41](#), triggers the value from **SSPxADD** to be loaded into the BRG counter. This occurs twice for each oscillation of the module clock line.

[Table 31-2](#) illustrates clock rates based on instruction cycles and the BRG value loaded into **SSPxADD**.

Example 31-1. MSSP Baud Rate Generator Frequency Equation

$$F_{CLOCK} = \frac{F_{OSC}}{4 \times (SSPxADD + 1)}$$

Figure 31-41. Baud Rate Generator Block Diagram

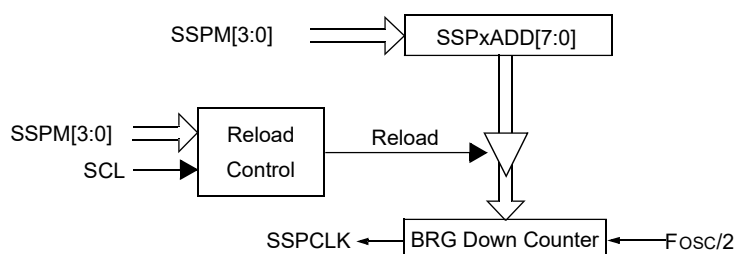

Important: Values of 0x00, 0x01 and 0x02 are not valid for **SSPxADD** when used as a Baud Rate Generator for I²C. This is an implementation limitation.

Table 31-2. MSSP Clock Rate w/BRG

F_{OSC}	F_{CY}	BRG Value	F_{CLOCK} (2 Rollovers of BRG)
32 MHz	8 MHz	13h	400 kHz
32 MHz	8 MHz	19h	308 kHz
32 MHz	8 MHz	4Fh	100 kHz
16 MHz	4 MHz	09h	400 kHz
16 MHz	4 MHz	0Ch	308 kHz
16 MHz	4 MHz	27h	100 kHz
4 MHz	1 MHz	09h	100 kHz

Note: Refer to the I/O port electrical specifications in the “**Electrical Specifications**” chapter, Internal Oscillator Parameters, to ensure the system is designed to support all requirements.

31.4 Register Definitions: MSSP Control

31.4.1 SSPxBUF

Name: SSPxBUF
Offset: 0x078C,0x0796

MSSP Data Buffer Register

Bit	7	6	5	4	3	2	1	0
	BUF[7:0]							
Access	R/W	R/W	R/W	R/W	R/W	R/W	R/W	R/W
Reset	x	x	x	x	x	x	x	x

Bits 7:0 – BUF[7:0] MSSP Input and Output Data Buffer bits

31.4.2 SSPxADD

Name: SSPxADD
Offset: 0x078D,0x0797

MSSP Baud Rate Divider and Address Register

Bit	7	6	5	4	3	2	1	0
	ADD[7:0]							
Access	R/W	R/W	R/W	R/W	R/W	R/W	R/W	R/W
Reset	0	0	0	0	0	0	0	0

Bits 7:0 – ADD[7:0]

- SPI and I²C Host: Baud rate divider
- I²C Client: Address bits

Value	Mode	Description
11111111 – 00000011	SPI and I ² C Host	Baud rate divider. SCK/SCL pin clock period = ((n + 1) * 4)/F _{OSC} . Values less than 3 are not valid in I ² C mode.
xxxxx11x– xxxxx00x	I ² C 10-bit Client MS Address	Bits [7:3] and Bit 0 are not used and are don't care. Bits [2:1] are bits [9:8] of the 10-bit Client Most Significant Address.
11111111 – 00000000	I ² C 10-bit Client LS Address	Bits [7:0] of 10-bit Client Least Significant Address
1111111x – 0000000x	I ² C 7-bit Client	Bit 0 is not used and is don't care. Bits [7:1] are the 7-bit Client Address.

31.4.3 SSPxMSK

Name: SSPxMSK
Offset: 0x078E,0x0798

MSSP Address Mask Register

Bit	7	6	5	4	3	2	1	0
	MSK[6:0]							MSK0
Access	R/W	R/W	R/W	R/W	R/W	R/W	R/W	R/W
Reset	1	1	1	1	1	1	1	1

Bits 7:1 – MSK[6:0] Mask bits

Value	Mode	Description
1	I ² C Client	The received address bit n is compared to SSPxADD bit n to detect I ² C address match
0	I ² C Client	The received address bit n is not used to detect I ² C address match

Bit 0 – MSK0 Mask bit for I²C 10-bit Client mode

Value	Mode	Description
x	SPI or I ² C 7-bit	This bit is not used
1	I ² C 10-bit Client	The received address bit 0 is compared to SSPxADD bit 0 to detect I ² C address match
0	I ² C 10-bit Client	The received address bit 0 is not used to detect I ² C address match

31.4.4 SSPxSTAT

Name: SSPxSTAT
Offset: 0x078F,0x0799

MSSP Status Register

Bit	7	6	5	4	3	2	1	0
	SMP	CKE	D/ \bar{A}	P	S	R/ \bar{W}	UA	BF
Access	R/W	R/W	R	R	R	R	R	R
Reset	0	0	0	0	0	0	0	0

Bit 7 – SMP Slew Rate Control bit

Value	Mode	Description
1	SPI Host	Input data are sampled at the end of data output time
0	SPI Host	Input data are sampled at the middle of data output time
0	SPI Client	Bit must be cleared in SPI Client mode
1	I ² C	Slew rate control is disabled for Standard Speed mode (100 kHz)
0	I ² C	Slew rate control is enabled for High Speed mode (400 kHz)

Bit 6 – CKE SPI: Clock Select bit⁽⁴⁾; I²C: SMBus Select bit

Value	Mode	Description
1	SPI	Transmit occurs on the transition from Active to Idle clock state
0	SPI	Transmit occurs on the transition from Idle to Active clock state
1	I ² C	Enables SMBus-specific inputs
0	I ² C	Disables SMBus-specific inputs

Bit 5 – D/ \bar{A} Data/Address bit

Value	Mode	Description
x	SPI or I ² C Host	This bit is not used
1	I ² C Client	Indicates that the last byte received or transmitted was data
0	I ² C Client	Indicates that the last byte received or transmitted was address

Bit 4 – P Stop bit⁽¹⁾

Value	Mode	Description
x	SPI	This bit is not used
1	I ² C	Stop bit was detected last
0	I ² C	Stop bit was not detected last

Bit 3 – S Start bit⁽¹⁾

Value	Mode	Description
x	SPI	This bit is not used
1	I ² C	Start bit was detected last
0	I ² C	Start bit was not detected last

Bit 2 – R/ \bar{W} Read/Write Information bit^(2,3)

Value	Mode	Description
x	SPI	This bit is not used
1	I ² C Client	Read
0	I ² C Client	Write
1	I ² C Host	Transmit is in progress
0	I ² C Host	Transmit is not in progress

Bit 1 – UA Update Address bit (10-bit I²C Client mode only)

Value	Mode	Description
x	All other modes	This bit is not used

Value	Mode	Description
1	I ² C 10-bit Client	Indicates that the user needs to update the address in the SSPxADD register
0	I ² C 10-bit Client	Address does not need to be updated

Bit 0 – BF Buffer Full Status bit⁽⁵⁾

Value	Mode	Description
1	I ² C Transmit	Transmit in progress, SSPxBUF is full
0	I ² C Transmit	Transmit complete; SSPxBUF is empty
1	SPI and I ² C Receive	Receive complete, SSPxBUF is full
0	SPI and I ² C Receive	Receive not complete, SSPxBUF is empty

Notes:

1. This bit is cleared on Reset and when SSPEN is cleared.
2. In I²C Client mode, this bit holds the R/ \overline{W} bit information following the last address match. This bit is only valid from the address match to the next Start bit, Stop bit or not \overline{ACK} bit.
3. ORing this bit with SEN, RSEN, PEN, RCEN or ACKEN will indicate if the MSSP is in Active mode.
4. Polarity of clock state is set by the CKP bit.
5. I²C receive status does not include \overline{ACK} and Stop bits.

31.4.5 SSPxCON1

Name: SSPxCON1
Offset: 0x0790,0x079A

MSSP Control Register 1

Bit	7	6	5	4	3	2	1	0
	WCOL	SSPOV	SSPEN	CKP	SSPM[3:0]			
Access	R/W/HS	R/W/HS	R/W	R/W	R/W	R/W	R/W	R/W
Reset	0	0	0	0	0	0	0	0

Bit 7 – WCOL Write Collision Detect bit

Value	Mode	Description
x	Host or Client receive	This bit is not used
1	SPI or I ² C Host or Client transmit	The SSPxBUF register is written while it is still transmitting the previous word (must be cleared in software)
0	SPI or I ² C Host or Client transmit	No collision

Bit 6 – SSPOV Receive Overflow Indicator bit⁽¹⁾

Value	Mode	Description
x	SPI Host or I ² C Host transmit	This bit is not used
1	SPI Client	A byte is received while the SSPxBUF register is still holding the previous byte. Data contained in the shift register will be discarded. The user must read SSPxBUF, even if only transmitting data, to avoid setting overflow (must be cleared in software).
1	I ² C Receive	A byte is received while the SSPxBUF register is still holding the previous byte (must be cleared in software)
0	SPI Client or I ² C Receive	No overflow

Bit 5 – SSPEN Host Synchronous Serial Port Enable bit⁽²⁾

Value	Description
1	Enables the serial port
0	Disables serial port and configures these pins as I/O PORT pins

Bit 4 – CKP SCK Release Control bit

Value	Mode	Description
x	I ² C Host	This bit is not used
1	SPI	Idle state for the clock is a high level
0	SPI	Idle state for the clock is a low level
1	I ² C Client	Releases clock
0	I ² C Client	Holds clock low (clock stretch), used to ensure data setup time

Bits 3:0 – SSPM[3:0] Host Synchronous Serial Port Mode Select bits⁽⁴⁾

Value	Description
1111	I ² C Client mode: 10-bit address with Start and Stop bit interrupts enabled
1110	I ² C Client mode: 7-bit address with Start and Stop bit interrupts enabled
1101	Reserved - do not use
1100	Reserved - do not use
1011	I ² C Firmware Controlled Host mode (client Idle)
1010	SPI Host mode: Clock = $F_{OSC}/(4*(SSPxADD+1))$
1001	Reserved - do not use
1000	I ² C Host mode: Clock = $F_{OSC}/(4 * (SSPxADD + 1))$ ⁽³⁾
0111	I ² C Client mode: 10-bit address
0110	I ² C Client mode: 7-bit address
0101	SPI Client mode: Clock = SCKx pin. \overline{SSx} pin control is disabled

Value	Description
0100	SPI Client mode: Clock = SCKx pin. \overline{SSx} pin control is enabled
0011	SPI Host mode: Clock = TMR2 output/2
0010	SPI Host mode: Clock = $F_{Osc}/64$
0001	SPI Host mode: Clock = $F_{Osc}/16$
0000	SPI Host mode: Clock = $F_{Osc}/4$

Notes:

1. In Host mode, the overflow bit is not set since each new reception (and transmission) is initiated by writing to the SSPxBUF register.
2. When enabled, these pins must be properly configured as inputs or outputs.
3. SSPxADD values of 0, 1, and 2 are not supported in I²C mode.
4. Bit combinations not specifically listed here are either reserved or implemented in I²C mode only.

31.4.6 SSPxCON2

Name: SSPxCON2
Offset: 0x0791,0x079B

MSSP Control Register 2

Control Register for I²C Operation Only

Bit	7	6	5	4	3	2	1	0
	GCEN	ACKSTAT	ACKDT	ACKEN	RCEN	PEN	RSEN	SEN
Access	R/W	R//HC/HS	R/W	R/W	R/W	R/W	R/W	R/W
Reset	0	0	0	0	0	0	0	0

Bit 7 – GCEN General Call Enable bit (Client mode only)

Value	Mode	Description
x	Host mode	Don't care
1	Client mode	General Call is enabled
0	Client mode	General Call is not enabled

Bit 6 – ACKSTAT Acknowledge Status bit (Host Transmit mode only)

Value	Description
1	Acknowledge was not received from client
0	Acknowledge was received from client

Bit 5 – ACKDT Acknowledge Data bit (Host Receive mode only)⁽¹⁾

Value	Description
1	Not Acknowledge
0	Acknowledge

Bit 4 – ACKEN Acknowledge Sequence Enable bit⁽²⁾

Value	Description
1	Initiates Acknowledge sequence on SDAx and SCLx pins and transmits ACKDT data bit; automatically cleared by hardware
0	Acknowledge sequence is Idle

Bit 3 – RCEN Receive Enable bit (Host Receive mode only)⁽²⁾

Value	Description
1	Enables Receive mode for I ² C
0	Receive is Idle

Bit 2 – PEN Stop Condition Enable bit (Host mode only)⁽²⁾

Value	Description
1	Initiates Stop condition on SDAx and SCLx pins; automatically cleared by hardware
0	Stop condition is Idle

Bit 1 – RSEN Repeated Start Condition Enable bit (Host mode only)⁽²⁾

Value	Description
1	Initiates Repeated Start condition on SDAx and SCLx pins; automatically cleared by hardware
0	Repeated Start condition is Idle

Bit 0 – SEN Start Condition Enable bit⁽²⁾

Value	Mode	Description
1	Host	Initiates Start condition on SDAx and SCLx pins; automatically cleared by hardware
0	Host	Start condition is Idle
1	Client	Clock stretching is enabled
0	Client	Clock stretching is disabled

Notes:

1. The value that will be transmitted when the user initiates an Acknowledge sequence at the end of a receive.
2. If the I²C module is active, these bits may not be set (no spooling) and the SSPxBUF may not be written (or writes to the SSPxBUF are disabled).

31.4.7 SSPxCON3

Name: SSPxCON3
Offset: 0x0792,0x079C

MSSP Control Register 3

Bit	7	6	5	4	3	2	1	0
	ACKTIM	PCIE	SCIE	BOEN	SDAHT	SBCDE	AHEN	DHEN
Access	R/HS/HC	R/W	R/W	R/W	R/W	R/W	R/W	R/W
Reset	0	0	0	0	0	0	0	0

Bit 7 – ACKTIM Acknowledge Time Status bit

Value	Mode	Description
x	SPI or I ² C Host	This bit is not used
1	I ² C Client and AHEN = 1 or DHEN = 1	Eighth falling edge of SCL has occurred and the $\overline{\text{ACK}}$ /NACK state is Active
0	I ² C Client	$\overline{\text{ACK}}$ /NACK state is not Active. Transitions low on ninth rising edge of SCL.

Bit 6 – PCIE Stop Condition Interrupt Enable bit

Value	Mode	Description
x	SPI or SSPM = 1111 or 1110	This bit is not used
1	SSPM \neq 1111 and SSPM \neq 1110	Enable interrupt on detection of Stop condition
0	SSPM \neq 1111 and SSPM \neq 1110	Stop detection interrupts are disabled

Bit 5 – SCIE Start Condition Interrupt Enable bit

Value	Mode	Description
x	SPI or SSPM = 1111 or 1110	This bit is not used
1	SSPM \neq 1111 and SSPM \neq 1110	Enable interrupt on detection of Start condition
0	SSPM \neq 1111 and SSPM \neq 1110	Start detection interrupts are disabled

Bit 4 – BOEN Buffer Overwrite Enable bit⁽¹⁾

Value	Mode	Description
1	SPI	SSPxBUF is updated every time a new data byte is available, ignoring the BF bit
0	SPI	If a new byte is receive with BF set then SSPOV is set and SSPxBUF is not updated
1	I ² C	SSPxBUF is updated every time a new data byte is available, ignoring the SSPOV effect on updating the buffer
0	I ² C	SSPxBUF is only updated when SSPOV is clear

Bit 3 – SDAHT SDA Hold Time Selection bit

Value	Mode	Description
x	SPI	Not used in SPI mode
1	I ² C	Minimum of 300 ns hold time on SDA after the falling edge of SCL
0	I ² C	Minimum of 100 ns hold time on SDA after the falling edge of SCL

Bit 2 – SBCDE Client Mode Bus Collision Detect Enable bit

Unused in Host mode.

Value	Mode	Description
x	SPI or I ² C Host	This bit is not used
1	I ² C Client	Bus Collision detection is enabled
0	I ² C Client	Bus Collision detection is not enabled

Bit 1 – AHEN Address Hold Enable bit

Value	Mode	Description
x	SPI or I ² C Host	This bit is not used
1	I ² C Client	Address hold is enabled. As a result, CKP is cleared after the eighth falling SCL edge of an address byte reception. Software must set the CKP bit to resume operation.

Value	Mode	Description
0	I ² C Client	Address hold is not enabled

Bit 0 – DHEN Data Hold Enable bit

Value	Mode	Description
x	SPI or I ² C Host	This bit is not used
1	I ² C Client	Data hold is enabled. As a result, CKP is cleared after the eighth falling SCL edge of a data byte reception. Software must set the CKP bit to resume operation.
0	I ² C Client	Data hold is not enabled

Note:

1. For daisy-chained SPI operation; allows the user to ignore all except the last received byte. SSPOV is still set when a new byte is received and BF = 1, but hardware continues to write the most recent byte to SSPxBUF.

31.5 Register Summary - MSSP Control

Offset	Name	Bit Pos.	7	6	5	4	3	2	1	0	
0x00 ...	Reserved										
0x078B											
0x078C	SSP1BUF	7:0	BUF[7:0]								
0x078D	SSP1ADD	7:0	ADD[7:0]								
0x078E	SSP1MSK	7:0	MSK[6:0]								MSK0
0x078F	SSP1STAT	7:0	SMP	CKE	D/Ā	P	S	R/W	UA	BF	
0x0790	SSP1CON1	7:0	WCOL	SSPOV	SSPEN	CKP	SSPM[3:0]				
0x0791	SSP1CON2	7:0	GCEN	ACKSTAT	ACKDT	ACKEN	RCEN	PEN	RSEN	SEN	
0x0792	SSP1CON3	7:0	ACKTIM	PCIE	SCIE	BOEN	SDAHT	SBCDE	AHEN	DHEN	
0x0793 ...	Reserved										
0x0795											
0x0796	SSP2BUF	7:0	BUF[7:0]								
0x0797	SSP2ADD	7:0	ADD[7:0]								
0x0798	SSP2MSK	7:0	MSK[6:0]								MSK0
0x0799	SSP2STAT	7:0	SMP	CKE	D/Ā	P	S	R/W	UA	BF	
0x079A	SSP2CON1	7:0	WCOL	SSPOV	SSPEN	CKP	SSPM[3:0]				
0x079B	SSP2CON2	7:0	GCEN	ACKSTAT	ACKDT	ACKEN	RCEN	PEN	RSEN	SEN	
0x079C	SSP2CON3	7:0	ACKTIM	PCIE	SCIE	BOEN	SDAHT	SBCDE	AHEN	DHEN	

32. EUSART - Enhanced Universal Synchronous Asynchronous Receiver Transmitter

The Enhanced Universal Synchronous Asynchronous Receiver Transmitter (EUSART) module is a serial I/O communications peripheral. It contains all the clock generators, shift registers and data buffers necessary to perform an input or output serial data transfer independent of device program execution. The EUSART, also known as a Serial Communications Interface (SCI), can be configured as a full-duplex asynchronous system or half-duplex synchronous system.

Full Duplex mode is useful for communications with peripheral systems, such as CRT terminals and personal computers. Half Duplex Synchronous mode is intended for communications with peripheral devices, such as A/D or D/A integrated circuits, serial EEPROMs or other microcontrollers. These devices typically do not have internal clocks for baud rate generation and require the external clock signal provided by a host synchronous device.

The EUSART module includes the following capabilities:

- Full-duplex asynchronous transmit and receive
- Two-character input buffer
- One-character output buffer
- Programmable 8-bit or 9-bit character length
- Address detection in 9-bit mode
- Input buffer overrun error detection
- Received character framing error detection
- Half-duplex synchronous host
- Half-duplex synchronous client
- Programmable clock polarity in Synchronous modes
- Sleep operation

The EUSART module implements the following additional features, making it ideally suited for use in Local Interconnect Network (LIN) bus systems:

- Automatic detection and calibration of the baud rate
- Wake-up on Break reception
- 13-bit Break character transmit

Block diagrams of the EUSART transmitter and receiver are shown in [Figure 32-1](#) and [Figure 32-2](#).

The operation of the EUSART module consists of six registers:

- Transmit Status and Control ([TXxSTA](#))
- Receive Status and Control ([RCxSTA](#))
- Baud Rate Control ([BAUDxCON](#))
- Baud Rate Value ([SPxBRG](#))
- Receive Data Register ([RCxREG](#))
- Transmit Data Register ([TXxREG](#))

The RXx/DTx and TXx/CKx input pins are selected with the RXxPPS and TXxPPS registers, respectively. TXx, CKx, and DTx output pins are selected with each pin's RxyPPS register. Since the RX input is coupled with the DT output in Synchronous mode, it is the user's responsibility to select the same pin for both of these functions when operating in Synchronous mode. The EUSART control logic will control the data direction drivers automatically.

Figure 32-1. EUSART Transmit Block Diagram

Rev. 10-00113C
2/15/2017

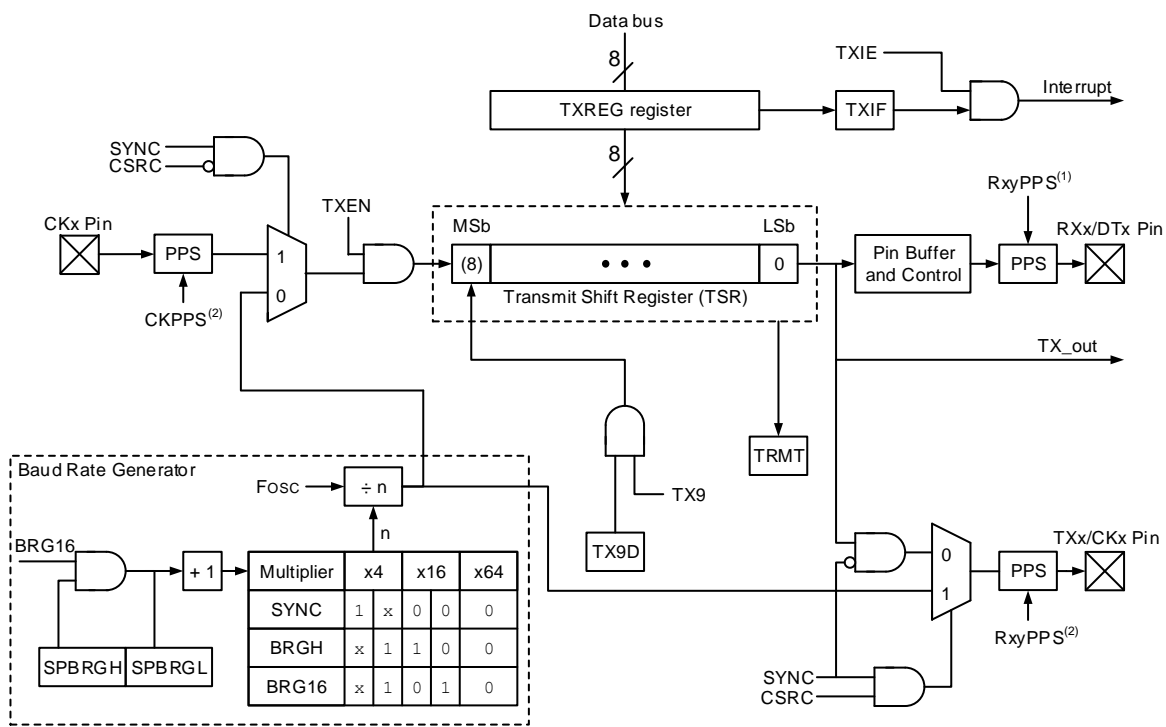

- Notes:**
1. In Synchronous mode, the DT output and RX input PPS selections will enable the same pin.
 2. In Host Synchronous mode, the TX output and CK input PPS selections will enable the same pin.

Figure 32-2. EUSART Receive Block Diagram

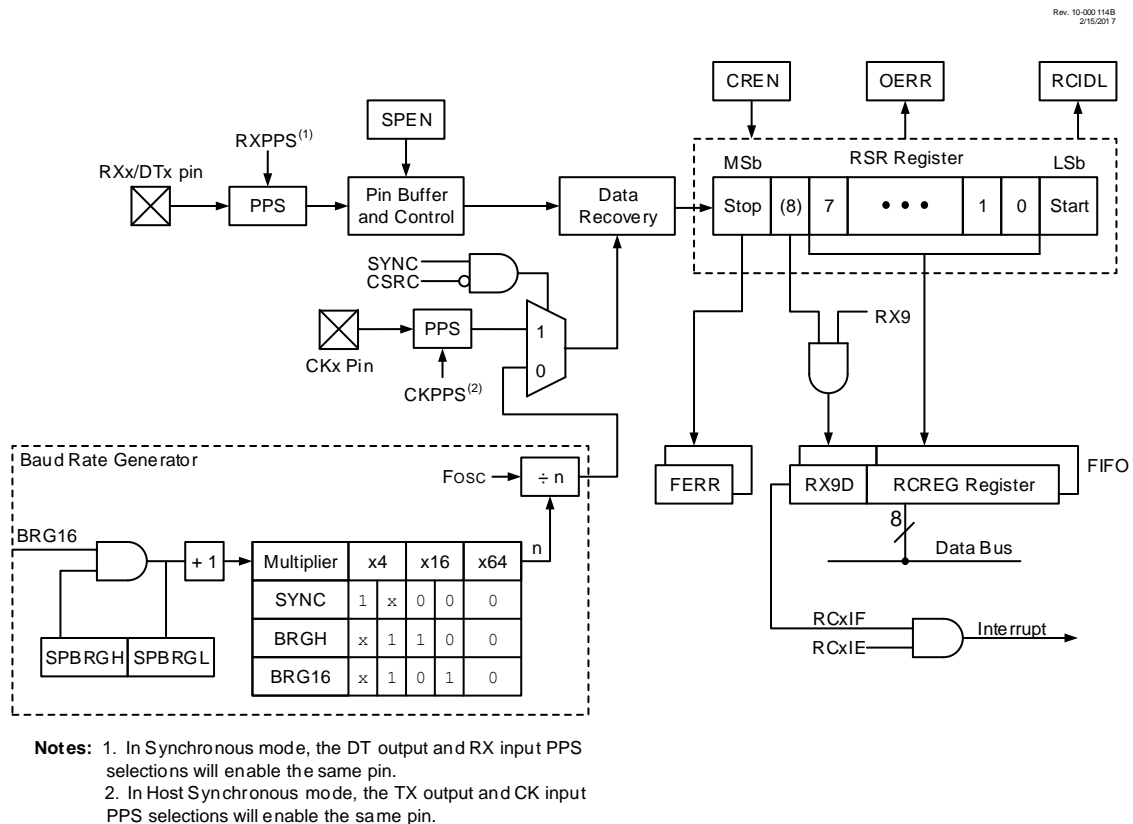

32.1 EUSART Asynchronous Mode

The EUSART transmits and receives data using the standard non-return-to-zero (NRZ) format. NRZ is implemented with two levels: a V_{OH} Mark state, which represents a '1' data bit, and a V_{OL} Space state, which represents a '0' data bit. NRZ refers to the fact that consecutively transmitted data bits of the same value stay at the output level of that bit without returning to a neutral level between each bit transmission. An NRZ transmission port idles in the Mark state. Each character transmission consists of one Start bit followed by eight or nine data bits and is always terminated by one or more Stop bits. The Start bit is always a space and the Stop bits are always marks. The most common data format is eight bits. Each transmitted bit persists for a period of $1/(\text{Baud Rate})$. An on-chip dedicated 8-bit/16-bit Baud Rate Generator is used to derive standard baud rate frequencies from the system oscillator. See [Table 32-2](#) for examples of baud rate configurations.

The EUSART transmits and receives the LSb first. The EUSART's transmitter and receiver are functionally independent, but share the same data format and baud rate. Parity is not supported by the hardware, but can be implemented in software and stored as the ninth data bit.

32.1.1 EUSART Asynchronous Transmitter

[Figure 32-1](#) is a simplified representation of the transmitter. The heart of the transmitter is the serial Transmit Shift Register (TSR), which is not directly accessible by software. The TSR obtains its data from the transmit buffer, which is the TXxREG register.

32.1.1.1 Enabling the Transmitter

The EUSART transmitter is enabled for asynchronous operations by configuring the following three control bits:

- The Transmit Enable (**TXEN**) bit is set to '1' to enable the transmitter circuitry of the EUSART

- The EUSART Mode Select (**SYNC**) bit is set to '0' to configure the EUSART for asynchronous operation
- The Serial Port Enable (**SPEN**) bit is set to '1' to enable the EUSART interface and to enable automatically the output drivers for the RxyPPS selected as the TXx/CKx output

All other EUSART control bits are assumed to be in their default state.

If the TXx/CKx pin is shared with an analog peripheral, the analog I/O function must be disabled by clearing the corresponding ANSEL bit.



Important: The TXxIF Transmitter Interrupt Flag in the PIRx register is set when the TXEN enable bit is set and the Transmit Shift Register (TSR) is Idle.

32.1.1.2 Transmitting Data

A transmission is initiated by writing a character to the **TXxREG** register. If this is the first character, or the previous character has been completely flushed from the TSR, the data in the **TXxREG** is immediately transferred to the TSR register. If the TSR still contains all or part of a previous character, the new character data are held in the **TXxREG** until the Stop bit of the previous character has been transmitted. The pending character in the **TXxREG** is then transferred to the TSR in one T_{CY} immediately following the Stop bit transmission. The transmission of the Start bit, data bits and Stop bit sequence commences immediately following the transfer of the data to the TSR from the **TXxREG**.

32.1.1.3 Transmit Data Polarity

The polarity of the transmit data can be controlled with the Clock/Transmit Polarity Select (**SCKP**) bit. The default state of this bit is '0', which selects high true transmit Idle and data bits. Setting the **SCKP** bit to '1' will invert the transmit data resulting in low true Idle and data bits. The **SCKP** bit controls transmit data polarity in Asynchronous mode only. In Synchronous mode, the **SCKP** bit has a different function. See [Clock Polarity](#) for more details.

32.1.1.4 Transmit Interrupt Flag

The EUSART Transmit Interrupt Flag (**TXxIF**) bit of the PIRx register is set whenever the EUSART transmitter is enabled and no character is being held for transmission in the **TXxREG**. In other words, the **TXxIF** bit is only cleared when the TSR is busy with a character and a new character has been queued for transmission in the **TXxREG**. The **TXxIF** flag bit is not cleared immediately upon writing **TXxREG**. **TXxIF** becomes valid in the second instruction cycle following the write execution. Polling **TXxIF** immediately following the **TXxREG** write will return invalid results. The **TXxIF** bit is read-only, it cannot be set or cleared by software.

The **TXxIF** interrupt can be enabled by setting the EUSART Transmit Interrupt Enable (**TXxIE**) bit of the PIRx register. However, the **TXxIF** flag bit will be set whenever the **TXxREG** is empty, regardless of the state of **TXxIE** enable bit.

To use interrupts when transmitting data, set the **TXxIE** bit only when there is more data to send. Clear the **TXxIE** interrupt enable bit upon writing the last character of the transmission to the **TXxREG**.

32.1.1.5 TSR Status

The Transmit Shift Register Status (**TRMT**) bit indicates the status of the TSR register. This is a read-only bit. The **TRMT** bit is set when the TSR register is empty and is cleared when a character is transferred to the TSR register from the **TXxREG**. The **TRMT** bit remains clear until all bits have been shifted out of the TSR register. No interrupt logic is tied to this bit, so the user needs to poll this bit to determine the TSR status.



Important: The TSR register is not mapped in data memory, so it is not available to the user.

32.1.1.6 Transmitting 9-Bit Characters

The EUSART supports 9-bit character transmissions. When the 9-Bit Transmit Enable (TX9) bit is set, the EUSART will shift nine bits out for each character transmitted. The TX9D bit is the ninth and Most Significant data bit. When transmitting 9-bit data, the TX9D data bit must be written before writing the eight Least Significant bits into the TXxREG. All nine bits of data will be transferred to the TSR register immediately after the TXxREG is written.

A special 9-bit Address mode is available for use with multiple receivers. See [Address Detection](#) for more information on the Address mode.

32.1.1.7 Asynchronous Transmission Setup

1. Initialize the SPxBRGH:SPxBRGL register pair and the BRGH and BRG16 bits to achieve the desired baud rate (see [EUSART Baud Rate Generator \(BRG\)](#)).
2. Select the transmit output pin by writing the appropriate value to the RxyPPS register.
3. Enable the asynchronous serial port by clearing the SYNC bit and setting the SPEN bit.
4. If 9-bit transmission is desired, set the TX9 control bit. That will indicate that the eight Least Significant data bits are an address when the receiver is set for address detection.
5. Set SCKP bit if inverted transmit is desired.
6. Enable the transmission by setting the TXEN control bit. This will cause the TXxIF interrupt bit to be set.
7. If interrupts are desired, set the TXxIE interrupt enable bit of the PEx register.
8. An interrupt will occur immediately provided that the GIE and PEIE bits of the INTCON register are also set.
9. If 9-bit transmission is selected, the ninth bit will be loaded into the TX9D data bit.
10. Load 8-bit data into the TXxREG register. This will start the transmission.

Figure 32-3. Asynchronous Transmission

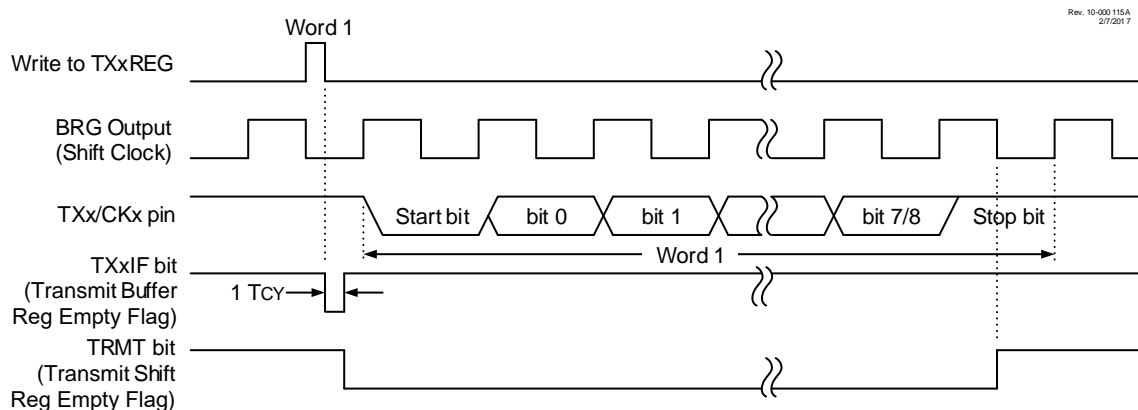
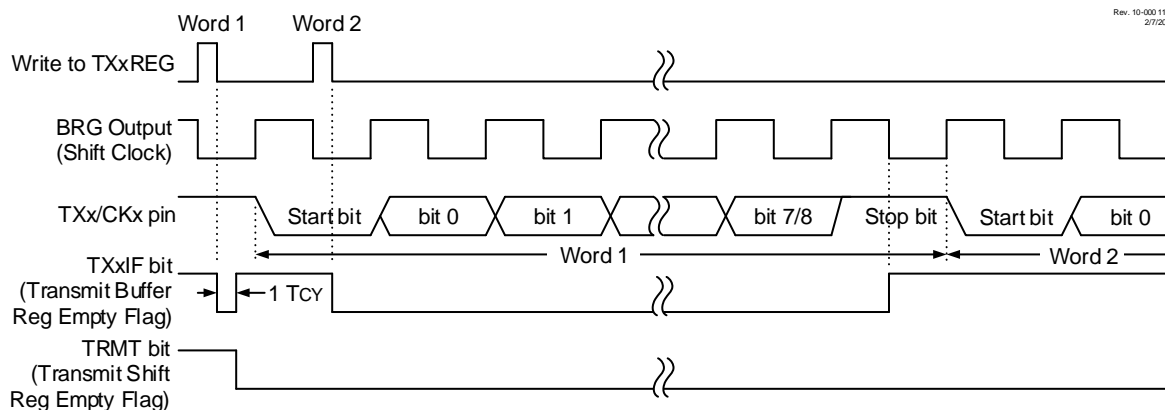

Figure 32-4. Asynchronous Transmission (Back-to-Back)

32.1.2 EUSART Asynchronous Receiver

The Asynchronous mode is typically used in RS-232 systems. A simplified representation of the receiver is shown in Figure 32-2. The data are received on the RXx/DTx pin and drive the data recovery block. The data recovery block is actually a high-speed shifter operating at 16 times the baud rate, whereas the serial Receive Shift Register (RSR) operates at the bit rate. When all eight or nine bits of the character have been shifted in, they are immediately transferred to a two character First-In-First-Out (FIFO) memory. The FIFO buffering allows reception of two complete characters and the start of a third character before software must start servicing the EUSART receiver. The FIFO and RSR registers are not directly accessible by software. Access to the received data is via the RCxREG register.

32.1.2.1 Enabling the Receiver

The EUSART receiver is enabled for asynchronous operation by configuring the following three control bits:

- The Continuous Receive Enable (CREN) bit is set to '1' to enables the receiver circuitry of the EUSART
- The EUSART Mode Select (SYNC) bit is set to '0' to configure the EUSART for asynchronous operation
- The Serial Port Enable (SPEN) bit is set to '1' to enable the EUSART interface

All other EUSART control bits are assumed to be in their default state.

The user must set the RXxPPS register to select the RXx/DTx I/O pin and set the corresponding TRIS bit to configure the pin as an input.



Important: If the RX/DT function is on an analog pin, the corresponding ANSEL bit must be cleared for the receiver to function.

32.1.2.2 Receiving Data

The receiver data recovery circuit initiates character reception on the falling edge of the first bit. The first bit, also known as the Start bit, is always a zero. The data recovery circuit counts one-half bit time to the center of the Start bit and verifies that the bit is still a zero. If it is not a zero, then the data recovery circuit aborts character reception without generating an error and resumes looking for the falling edge of the Start bit. If the Start bit zero verification succeeds, then the data recovery circuit counts a full bit time to the center of the next bit. The bit is then sampled by a majority detect circuit and the resulting '0' or '1' is shifted into the RSR. This repeats until all data bits have been

sampled and shifted into the RSR. One final bit time is measured and the level sampled. This is the Stop bit, which is always a '1'. If the data recovery circuit samples a '0' in the Stop bit position, then a framing error is set for this character, otherwise the framing error is cleared for this character. See [Receive Framing Error](#) for more information on framing errors.

Immediately after all data bits and the Stop bit have been received, the character in the RSR is transferred to the EUSART receive FIFO, and the EUSART Receive Interrupt Flag (RCxIF) bit of the PIRx register is set. The top character in the FIFO is transferred out of the FIFO by reading the [RCxREG](#) register.



Important: If the receive FIFO is overrun, no additional characters will be received until the Overrun condition is cleared. See [Receive Framing Error](#) for more information.

32.1.2.3 Receive Interrupts

The EUSART Receive Interrupt Flag (RCxIF) bit of the PIRx register is set whenever the EUSART receiver is enabled and there is an unread character in the receive FIFO. The RCxIF Interrupt Flag bit is read-only, it cannot be set or cleared by software.

RCxIF interrupts are enabled by setting all of the following bits:

- RCxIE, Interrupt Enable bit of the PIRx register
- PEIE, Peripheral Interrupt Enable bit of the INTCON register
- GIE, Global Interrupt Enable bit of the INTCON register

The RCxIF Interrupt Flag bit will be set when there is an unread character in the FIFO, regardless of the state of interrupt enable bits.

32.1.2.4 Receive Framing Error

Each character in the receive FIFO buffer has a corresponding framing error Status bit. A framing error indicates that a Stop bit was not seen at the expected time. The framing error status is accessed via the Framing Error (FERR) bit. The FERR bit represents the status of the top unread character in the receive FIFO. Therefore, the FERR bit must be read before reading the [RCxREG](#) register.

The FERR bit is read-only and only applies to the top unread character in the receive FIFO. A framing error (FERR = 1) does not preclude reception of additional characters. It is not necessary to clear the FERR bit. Reading the next character from the FIFO buffer will advance the FIFO to the next character and the next corresponding framing error.

The FERR bit can be forced clear by clearing the [SPEN](#) bit, which resets the EUSART. Clearing the [CREN](#) bit does not affect the FERR bit. A framing error by itself does not generate an interrupt.



Important: If all receive characters in the receive FIFO have framing errors, repeated reads of the RCxREG register will not clear the FERR bit.

32.1.2.5 Receive Overrun Error

The receive FIFO buffer can hold two characters. An overrun error will be generated if a third character, in its entirety, is received before the FIFO is accessed. When this happens the Overrun Error (OERR) bit is set. The characters already in the FIFO buffer can be read but no additional characters will be received until the error is cleared. The error must be cleared by either clearing the [CREN](#) bit or by resetting the EUSART by clearing the [SPEN](#) bit.

32.1.2.6 Receiving 9-Bit Characters

The EUSART supports 9-bit character reception. When the 9-Bit Receive Enable (RX9) bit is set, the EUSART will shift nine bits into the RSR for each character received. The RX9D bit is the ninth and Most Significant data bit of the top unread character in the receive FIFO. When reading 9-bit data from the receive FIFO buffer, the RX9D data bit must be read before reading the eight Least Significant bits from the RCxREG register.

32.1.2.7 Address Detection

A special Address Detection mode is available for use when multiple receivers share the same transmission line, such as in RS-485 systems. Address detection is enabled by setting the Address Detect Enable (ADDEN) bit.

Address detection requires 9-bit character reception. When address detection is enabled, only characters with the ninth data bit set will be transferred to the receive FIFO buffer, thereby setting the RCxIF interrupt bit. All other characters will be ignored.

Upon receiving an address character, user software determines if the address matches its own. Upon address match, user software must disable address detection by clearing the ADDEN bit before the next Stop bit occurs. When user software detects the end of the message, determined by the message protocol used, software places the receiver back into the Address Detection mode by setting the ADDEN bit.

32.1.2.8 Asynchronous Reception Setup

1. Initialize the SPxBRGH:SPxBRGL register pair and the BRGH and BRG16 bits to achieve the desired baud rate (see [EUSART Baud Rate Generator \(BRG\)](#)).
2. Set the RXxPPS register to select the RXx/DTx input pin.
3. Clear the ANSEL bit for the RXx pin (if applicable).
4. Enable the serial port by setting the SPEN bit. The SYNC bit must be cleared for asynchronous operation.
5. If interrupts are desired, set the RCxIE bit of the PIRx register and the GIE and PEIE bits of the INTCON register.
6. If 9-bit reception is desired, set the RX9 bit.
7. Enable reception by setting the CREN bit.
8. The RCxIF Interrupt Flag bit will be set when a character is transferred from the RSR to the receive buffer. An interrupt will be generated if the RCxIE interrupt enable bit was also set.
9. Read the RCxSTA register to get the Error flags and, if 9-bit data reception is enabled, the ninth data bit.
10. Get the received eight Least Significant data bits from the receive buffer by reading the RCxREG register.
11. If an overrun occurred, clear the OERR flag by clearing the CREN receiver enable bit.

32.1.2.9 9-Bit Address Detection Mode Setup

This mode is typically used in RS-485 systems. To set up an Asynchronous Reception with Address Detect Enable, follow these steps:

1. Initialize the SPxBRGH:SPxBRGL register pair and the BRGH and BRG16 bits to achieve the desired baud rate (see [EUSART Baud Rate Generator \(BRG\)](#)).
2. Set the RXxPPS register to select the RXx input pin.
3. Clear the ANSEL bit for the RXx pin (if applicable).
4. Enable the serial port by setting the SPEN bit. The SYNC bit must be cleared for asynchronous operation.
5. If interrupts are desired, set the RCxIE bit of the PIRx register and the GIE and PEIE bits of the INTCON register.

6. Enable 9-bit reception by setting the [RX9](#) bit.
7. Enable address detection by setting the [ADDEN](#) bit.
8. Enable reception by setting the [CREN](#) bit.
9. The RCxIF Interrupt Flag bit will be set when a character with the ninth bit set is transferred from the RSR to the receive buffer. An interrupt will be generated if the RCxIE interrupt enable bit is also set.
10. Read the [RCxSTA](#) register to get the Error flags. The ninth data bit will always be set.
11. Get the received eight Least Significant data bits from the receive buffer by reading the [RCxREG](#) register. Software determines if this is the device's address.
12. If an overrun occurred, clear the [OERR](#) flag by clearing the CREN receiver enable bit.
13. If the device has been addressed, clear the ADDEN bit to allow all received data into the receive buffer and generate interrupts.

Figure 32-5. Asynchronous Reception

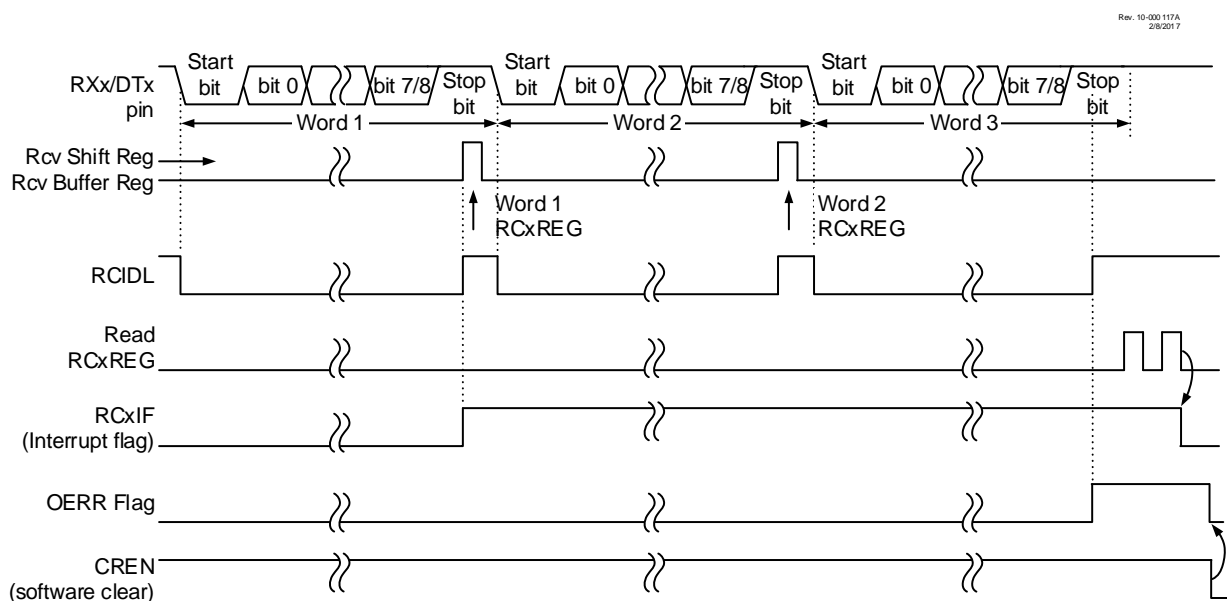

Note: This timing diagram shows three bytes appearing on the RXx input. The OERR flag is set because the RCxREG register is not read before the third word is received.

32.2 Clock Accuracy with Asynchronous Operation

The factory calibrates the internal oscillator block output (INTOSC). However, the INTOSC frequency may drift as V_{DD} or temperature changes, directly affecting the asynchronous baud rate. Two methods may be used to adjust the baud rate clock, but both require a reference clock source of some kind.

The first (preferred) method uses the OSCTUNE register to adjust the INTOSC output. Adjusting the value in the OSCTUNE register allows for fine resolution changes to the system clock source.

The other method adjusts the value in the Baud Rate Generator. This can be done automatically with the Auto-Baud Detect feature (see [Auto-Baud Detect](#)). There may not be fine enough resolution when adjusting the Baud Rate Generator to compensate for a gradual change in the peripheral clock frequency.

32.3 EUSART Baud Rate Generator (BRG)

The Baud Rate Generator (BRG) is an 8-bit or 16-bit timer that is dedicated to the support of both the asynchronous and synchronous EUSART operations. By default, the BRG operates in 8-bit mode. Setting the **BRG16** bit selects 16-bit mode.

The SPxBRGH:SPxBRGL register pair determines the period of the free-running baud rate timer. In Asynchronous mode, the multiplier of the baud rate period is determined by both the **BRGH** and the BRG16 bits. In Synchronous mode, the BRGH bit is ignored.

Table 32-1 contains the formulas for determining the baud rate. **Equation 32-1** provides a sample calculation for determining the baud rate and baud rate error.

Typical baud rates and error values for various Asynchronous modes have been computed and are shown in the table below. It may be advantageous to use the high baud rate (BRGH = 1) or the 16-bit BRG (BRG16 = 1) to reduce the baud rate error. The 16-bit BRG mode is used to achieve slow baud rates for fast oscillator frequencies. The BRGH bit is used to achieve very high baud rates.

Writing a new value to the SPxBRGH:SPxBRGL register pair causes the BRG timer to be reset (or cleared). This ensures that the BRG does not wait for a timer overflow before outputting the new baud rate.

If the system clock is changed during an active receive operation, a receive error or data loss may result. To avoid this, check the status of the Receive Idle Flag (**RCIDL**) bit to make sure the receive operation is idle before changing the system clock.

Equation 32-1. Calculating Baud Rate Error

For a device with F_{OSC} of 16 MHz, desired baud rate of 9600, Asynchronous mode, 8-bit BRG:

$$DesiredBaudrate = \frac{F_{OSC}}{64 \times (SPxBRG + 1)}$$

Solving for SPxBRG:

$$SPxBRG = \frac{F_{OSC}}{64 \times DesiredBaudrate} - 1$$

$$SPxBRG = \frac{16000000}{64 \times 9600} - 1$$

$$SPxBRG = 25.042 \approx 25$$

$$CalculatedBaudrate = \frac{16000000}{64 \times (25 + 1)}$$

$$CalculatedBaudrate = 9615$$

$$Error = \frac{CalculatedBaudrate - DesiredBaudrate}{DesiredBaudrate}$$

$$Error = \frac{9615 - 9600}{9600}$$

$$Error = 0.16\%$$

Table 32-1. Baud Rate Formulas

Configuration Bits			BRG/EUSART Mode	Baud Rate Formula
SYNC	BRG16	BRGH		
0	0	0	8-bit/Asynchronous	$F_{OSC}/[64(n+1)]$
0	0	1	8-bit/Asynchronous	$F_{OSC}/[64(n+1)]$
0	1	0	16-bit/Asynchronous	$F_{OSC}/[16(n+1)]$

.....continued

Configuration Bits			BRG/EUSART Mode	Baud Rate Formula
SYNC	BRG16	BRGH		
0	1	1	16-bit/Asynchronous	$F_{OSC}/[4(n+1)]$
1	0	x	8-bit/Synchronous	
1	1	x	16-bit/Synchronous	

Note: x = Don't care, n = value of SPxBRGH:SPxBRGL register pair.

Table 32-2. Sample Baud Rates for Asynchronous Modes

Baud Rate	SYNC = 0, BRGH = 0, BRG16 = 0											
	$F_{OSC} = 32.000$ MHz			$F_{OSC} = 20.000$ MHz			$F_{OSC} = 18.432$ MHz			$F_{OSC} = 11.0592$ MHz		
	Actual Rate	% Error	SPBRG value (decimal)	Actual Rate	% Error	SPBRG value (decimal)	Actual Rate	% Error	SPBRG value (decimal)	Actual Rate	% Error	SPBRG value (decimal)
300	—	—	—	—	—	—	—	—	—	—	—	—
1200	—	—	—	1221	1.73	255	1200	0.00	239	1200	0.00	143
2400	2404	0.16	207	2404	0.16	129	2400	0.00	119	2400	0.00	71
9600	9615	0.16	51	9470	-1.36	32	9600	0.00	29	9600	0.00	17
10417	10417	0.00	47	10417	0.00	29	10286	-1.26	27	10165	-2.42	16
19.2k	19.23k	0.16	25	19.53k	1.73	15	19.20k	0.00	14	19.20k	0.00	8
57.6k	55.55k	-3.55	3	—	—	—	57.60k	0.00	7	57.60k	0.00	2
115.2k	—	—	—	—	—	—	—	—	—	—	—	—

Baud Rate	SYNC = 0, BRGH = 0, BRG16 = 0											
	$F_{OSC} = 8.000$ MHz			$F_{OSC} = 4.000$ MHz			$F_{OSC} = 3.6864$ MHz			$F_{OSC} = 1.000$ MHz		
	Actual Rate	% Error	SPBRG value (decimal)	Actual Rate	% Error	SPBRG value (decimal)	Actual Rate	% Error	SPBRG value (decimal)	Actual Rate	% Error	SPBRG value (decimal)
300	—	—	—	300	0.16	207	300	0.00	191	300	0.16	51
1200	1202	0.16	103	1202	0.16	51	1200	0.00	47	1202	0.16	12
2400	2404	0.16	51	2404	0.16	25	2400	0.00	23	—	—	—
9600	9615	0.16	12	—	—	—	9600	0.00	5	—	—	—
10417	10417	0.00	11	10417	0.00	5	—	—	—	—	—	—
19.2k	—	—	—	—	—	—	19.20k	0.00	2	—	—	—
57.6k	—	—	—	—	—	—	57.60k	0.00	0	—	—	—
115.2k	—	—	—	—	—	—	—	—	—	—	—	—

Baud Rate	SYNC = 0, BRGH = 1, BRG16 = 0											
	$F_{OSC} = 32.000$ MHz			$F_{OSC} = 20.000$ MHz			$F_{OSC} = 18.432$ MHz			$F_{OSC} = 11.0592$ MHz		
	Actual Rate	% Error	SPBRG value (decimal)	Actual Rate	% Error	SPBRG value (decimal)	Actual Rate	% Error	SPBRG value (decimal)	Actual Rate	% Error	SPBRG value (decimal)
300	—	—	—	—	—	—	—	—	—	—	—	—
1200	—	—	—	—	—	—	—	—	—	—	—	—
2400	—	—	—	—	—	—	—	—	—	—	—	—
9600	9615	0.16	207	9615	0.16	129	9600	0.00	119	9600	0.00	71
10417	10417	0.00	191	10417	0.00	119	10378	-0.37	110	10473	0.53	65
19.2k	19.23k	0.16	103	19.23k	0.16	64	19.20k	0.00	59	19.20k	0.00	35
57.6k	57.14k	-0.79	34	56.82k	-1.36	21	57.60k	0.00	19	57.60k	0.00	11

EUSART - Enhanced Universal Synchronous Asynchronous Receiver Transmitter

115.2k	117.64k	2.12	16	113.64k	-1.36	10	115.2k	0.00	9	115.2k	0.00	5
--------	---------	------	----	---------	-------	----	--------	------	---	--------	------	---

Baud Rate	SYNC = 0, BRGH = 1, BRG16 = 0											
	F _{OSC} = 8.000 MHz			F _{OSC} = 4.000 MHz			F _{OSC} = 3.6864 MHz			F _{OSC} = 1.000 MHz		
	Actual Rate	% Error	SPBRG value (decimal)	Actual Rate	% Error	SPBRG value (decimal)	Actual Rate	% Error	SPBRG value (decimal)	Actual Rate	% Error	SPBRG value (decimal)
300	—	—	—	—	—	—	—	—	—	300	0.16	207
1200	—	—	—	1202	0.16	207	1200	0.00	191	1202	0.16	51
2400	2404	0.16	207	2404	0.16	103	2400	0.00	95	2404	0.16	25
9600	9615	0.16	51	9615	0.16	25	9600	0.00	23	—	—	—
10417	10417	0.00	47	10417	0.00	23	10473	0.53	21	10417	0.00	5
19.2k	19231	0.16	25	19.23k	0.16	12	19.2k	0.00	11	—	—	—
57.6k	55556	-3.55	8	—	—	—	57.60k	0.00	3	—	—	—
115.2k	—	—	—	—	—	—	115.2k	0.00	1	—	—	—

Baud Rate	SYNC = 0, BRGH = 0, BRG16 = 1											
	F _{OSC} = 32.000 MHz			F _{OSC} = 20.000 MHz			F _{OSC} = 18.432 MHz			F _{OSC} = 11.0592 MHz		
	Actual Rate	% Error	SPBRG value (decimal)	Actual Rate	% Error	SPBRG value (decimal)	Actual Rate	% Error	SPBRG value (decimal)	Actual Rate	% Error	SPBRG value (decimal)
300	300.0	0.00	6666	300.0	-0.01	4166	300.0	0.00	3839	300.0	0.00	2303
1200	1200	-0.02	3332	1200	-0.03	1041	1200	0.00	959	1200	0.00	575
2400	2401	-0.04	832	2399	-0.03	520	2400	0.00	479	2400	0.00	287
9600	9615	0.16	207	9615	0.16	129	9600	0.00	119	9600	0.00	71
10417	10417	0.00	191	10417	0.00	119	10378	-0.37	110	10473	0.53	65
19.2k	19.23k	0.16	103	19.23k	0.16	64	19.20k	0.00	59	19.20k	0.00	35
57.6k	57.14k	-0.79	34	56.818	-1.36	21	57.60k	0.00	19	57.60k	0.00	11
115.2k	117.6k	2.12	16	113.636	-1.36	10	115.2k	0.00	9	115.2k	0.00	5

Baud Rate	SYNC = 0, BRGH = 0, BRG16 = 1											
	F _{OSC} = 8.000 MHz			F _{OSC} = 4.000 MHz			F _{OSC} = 3.6864 MHz			F _{OSC} = 1.000 MHz		
	Actual Rate	% Error	SPBRG value (decimal)	Actual Rate	% Error	SPBRG value (decimal)	Actual Rate	% Error	SPBRG value (decimal)	Actual Rate	% Error	SPBRG value (decimal)
300	299.9	-0.02	1666	300.1	0.04	832	300.0	0.00	767	300.5	0.16	207
1200	1199	-0.08	416	1202	0.16	207	1200	0.00	191	1202	0.16	51
2400	2404	0.16	207	2404	0.16	103	2400	0.00	95	2404	0.16	25
9600	9615	0.16	51	9615	0.16	25	9600	0.00	23	—	—	—
10417	10417	0.00	47	10417	0.00	23	10473	0.53	21	10417	0.00	5
19.2k	19.23k	0.16	25	19.23k	0.16	12	19.20k	0.00	11	—	—	—
57.6k	55556	-3.55	8	—	—	—	57.60k	0.00	3	—	—	—
115.2k	—	—	—	—	—	—	115.2k	0.00	1	—	—	—

Baud Rate	SYNC = 0, BRGH = 1, BRG16 = 1 or SYNC = 1, BRG16 = 1											
	F _{OSC} = 32.000 MHz			F _{OSC} = 20.000 MHz			F _{OSC} = 18.432 MHz			F _{OSC} = 11.0592 MHz		
	Actual Rate	% Error	SPBRG value (decimal)	Actual Rate	% Error	SPBRG value (decimal)	Actual Rate	% Error	SPBRG value (decimal)	Actual Rate	% Error	SPBRG value (decimal)

300	300.0	0.00	26666	300.0	0.00	16665	300.0	0.00	15359	300.0	0.00	9215
1200	1200	0.00	6666	1200	-0.01	4166	1200	0.00	3839	1200	0.00	2303
2400	2400	0.01	3332	2400	0.02	2082	2400	0.00	1919	2400	0.00	1151
9600	9604	0.04	832	9597	-0.03	520	9600	0.00	479	9600	0.00	287
10417	10417	0.00	767	10417	0.00	479	10425	0.08	441	10433	0.16	264
19.2k	19.18k	-0.08	416	19.23k	0.16	259	19.20k	0.00	239	19.20k	0.00	143
57.6k	57.55k	-0.08	138	57.47k	-0.22	86	57.60k	0.00	79	57.60k	0.00	47
115.2k	115.9k	0.64	68	116.3k	0.94	42	115.2k	0.00	39	115.2k	0.00	23

Baud Rate	SYNC = 0, BRGH = 1, BRG16 = 1 or SYNC = 1, BRG16 = 1											
	F _{OSC} = 8.000 MHz			F _{OSC} = 4.000 MHz			F _{OSC} = 3.6864 MHz			F _{OSC} = 1.000 MHz		
	Actual Rate	% Error	SPBRG value (decimal)	Actual Rate	% Error	SPBRG value (decimal)	Actual Rate	% Error	SPBRG value (decimal)	Actual Rate	% Error	SPBRG value (decimal)
300	300.0	0.00	6666	300.0	0.01	3332	300.0	0.00	3071	300.1	0.04	832
1200	1200	-0.02	1666	1200	0.04	832	1200	0.00	767	1202	0.16	207
2400	2401	0.04	832	2398	0.08	416	2400	0.00	383	2404	0.16	103
9600	9615	0.16	207	9615	0.16	103	9600	0.00	95	9615	0.16	25
10417	10417	0	191	10417	0.00	95	10473	0.53	87	10417	0.00	23
19.2k	19.23k	0.16	103	19.23k	0.16	51	19.20k	0.00	47	19.23k	0.16	12
57.6k	57.14k	-0.79	34	58.82k	2.12	16	57.60k	0.00	15	—	—	—
115.2k	117.6k	2.12	16	111.1k	-3.55	8	115.2k	0.00	7	—	—	—

32.3.1 Auto-Baud Detect

The EUSART module supports automatic detection and calibration of the baud rate.

In the Auto-Baud Detect (ABD) mode, the clock to the BRG is reversed. Rather than the BRG clocking the incoming RX signal, the RX signal is timing the BRG. The Baud Rate Generator is used to time the period of a received 55h (ASCII "U") which is the Sync character for the LIN bus. The unique feature of this character is that it has five rising edges, including the Stop bit edge.

Setting the Auto-Baud Detect Enable (**ABDEN**) bit starts the auto-baud calibration sequence. While the ABD sequence takes place, the EUSART state machine is held in Idle. On the first rising edge of the receive line, after the Start bit, the **SPxBRG** register begins counting up using the BRG counter clock as shown in [Figure 32-6](#). The fifth rising edge will occur on the RXx pin at the end of the eighth bit period. At that time, an accumulated value totaling the proper BRG period is left in the SPxBRGH:SPxBRGL register pair, the ABDEN bit is automatically cleared, and the RCxIF interrupt flag is set. The value in the **RCxREG** register needs to be read to clear the RCxIF interrupt. RCxREG content may be discarded. When calibrating for modes that do not use the SPxBRGH register, the user can verify that the SPxBRGL register did not overflow by checking for 00h in the SPxBRGH register.

The BRG auto-baud clock is determined by the **BRG16** and **BRGH** bits, as shown in [Table 32-3](#). During ABD, both the SPxBRGH and SPxBRGL registers are used as a 16-bit counter, independent of the BRG16 bit setting. While calibrating the baud rate period, the SPxBRGH and SPxBRGL registers are clocked at 1/8th the BRG base clock rate. The resulting byte measurement is the average bit time when clocked at full speed.

Notes:

1. If the Wake-Up Enable (**WUE**) bit is set with the **ABDEN** bit, auto-baud detection will occur on the byte following the Break character (see [Auto-Wake-Up on Break](#)).
2. It is up to the user to determine that the incoming character baud rate is within the range of the selected BRG clock source. Some combinations of oscillator frequency and EUSART baud rates are not possible.
3. During the auto-baud process, the auto-baud counter starts counting at one. Upon completion of the auto-baud sequence, to achieve maximum accuracy, subtract 1 from the **SPxBRGH:SPxBRGL** register pair.

Table 32-3. BRG Counter Clock Rates

BRG16	BRGH	BRG Base Clock	BRG ABD Clock
1	1	$F_{osc}/4$	$F_{osc}/32$
1	0	$F_{osc}/16$	$F_{osc}/128$
0	1	$F_{osc}/16$	$F_{osc}/128$
0	0	$F_{osc}/64$	$F_{osc}/512$

Note: During the ABD sequence, the **SPxBRGL** and **SPxBRGH** registers are both used as a 16-bit counter, independent of the BRG16 setting.

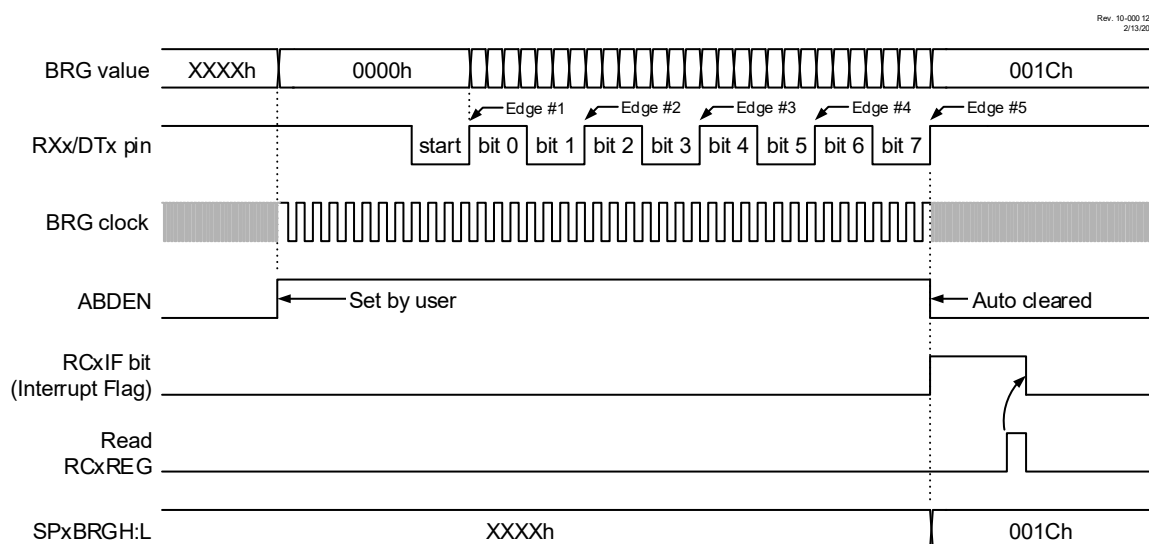
Figure 32-6. Automatic Baud Rate Calibration**32.3.2 Auto-Baud Overflow**

During the course of automatic baud detection, the Auto-Baud Detect Overflow (**ABDOVF**) bit will be set if the baud rate counter overflows before the fifth rising edge is detected on the **RXx** pin. The **ABDOVF** bit indicates that the counter has exceeded the maximum count that can fit in the 16 bits of the **SPxBRGH:SPxBRGL** register pair. After the **ABDOVF** bit has been set, the counter continues to count until the fifth rising edge is detected on the **RXx** pin. Upon detecting the fifth **RX** edge, the hardware will set the **RCxIF** interrupt flag and clear the **ABDEN** bit. The **RCxIF** flag can be subsequently cleared by reading the **RCxREG** register. The **ABDOVF** bit can be cleared by software directly.

To terminate the auto-baud process before the **RCxIF** flag is set, clear the **ABDEN** bit then clear the **ABDOVF** bit. The **ABDOVF** bit will remain set if the **ABDEN** bit is not cleared first.

32.3.3 Auto-Wake-Up on Break

During Sleep mode, all clocks to the EUSART are suspended. Because of this, the Baud Rate Generator is inactive and a proper character reception cannot be performed. The Auto-Wake-Up feature allows the controller to wake up due to activity on the RX/DT line. This feature is available only in Asynchronous mode.

The Auto-Wake-Up feature is enabled by setting the **WUE** bit. Once set, the normal receive sequence on RX/DT is disabled, and the EUSART remains in an Idle state, monitoring for a wake-up event independent of the CPU mode. A wake-up event consists of a high-to-low transition on the RX/DT line. This coincides with the start of a Sync Break or a wake-up signal character for the LIN protocol.

The EUSART module generates an RCxIF interrupt coincident with the wake-up event. The interrupt is generated synchronously to the Q clocks in normal CPU operating modes, as shown in [Figure 32-7](#), and asynchronously if the device is in Sleep mode, as shown in [Figure 32-8](#). The Interrupt condition is cleared by reading the **RCxREG** register.

The WUE bit is automatically cleared by the low-to-high transition on the RX line at the end of the Break. This signals to the user that the Break event is over. At this point, the EUSART module is in Idle mode waiting to receive the next character.

32.3.3.1 Special Considerations

Break Character

To avoid character errors or character fragments during a wake-up event, the wake-up character must be all zeros.

When the wake-up is enabled, the function works independent of the low time on the data stream. If the **WUE** bit is set and a valid nonzero character is received, the low time from the Start bit to the first rising edge will be interpreted as the wake-up event. The remaining bits in the character will be received as a fragmented character and subsequent characters can result in framing or overrun errors.

Therefore, the initial character in the transmission must be all '0's. This must be 10 or more bit times, 13-bit times recommended for LIN bus, or any number of bit times for standard RS-232 devices.

WUE Bit

The wake-up event causes a receive interrupt by setting the RCxIF bit. The WUE bit is cleared in hardware by a rising edge on RX/DT. The Interrupt condition is then cleared in software by reading the **RCxREG** register and discarding its contents.

To ensure that no actual data are lost, check the **RCIDL** bit to verify that a receive operation is not in process before setting the WUE bit. If a receive operation is not occurring, the WUE bit may then be set just prior to entering the Sleep mode.

Figure 32-7. Auto-Wake-Up (WUE) Bit Timing During Normal Operation

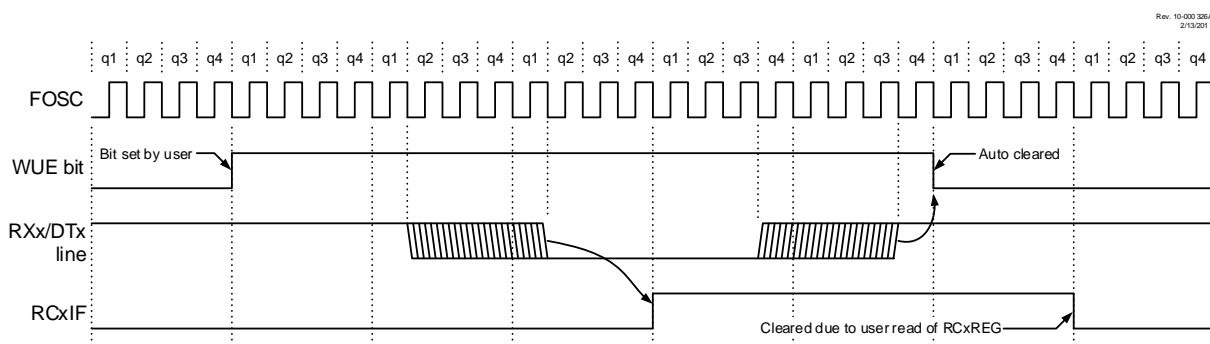

Note: The EUSART remains in Idle while the WUE bit is set.

Figure 32-8. Auto-Wake-Up (WUE) Bit Timings During Sleep

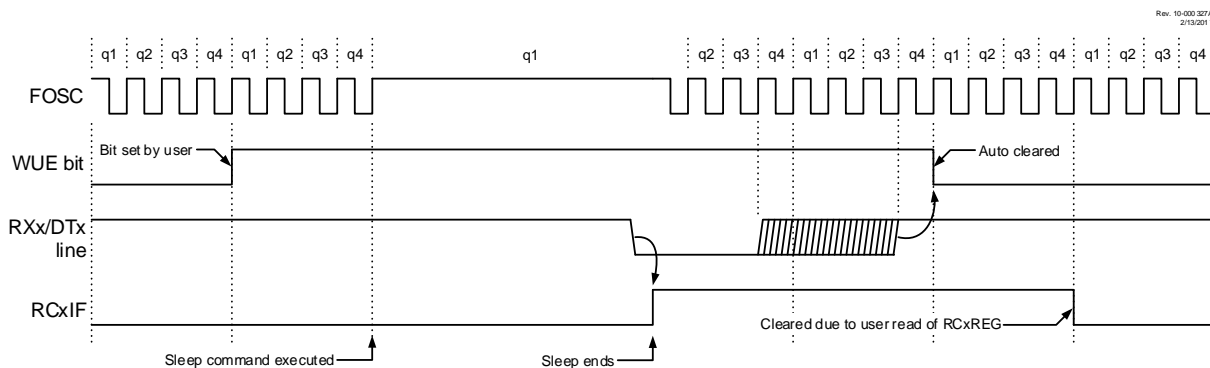

Note: The EUSART remains in Idle while the WUE bit is set.

32.3.4 Break Character Sequence

The EUSART module has the capability of sending the special Break character sequences that are required by the LIN bus standard. A Break character consists of a Start bit, followed by 12 '0' bits and a Stop bit.

To send a Break character, set the Send Break Character (**SENDB**) and Transmit Enable (**TXEN**) bits. The Break character transmission is then initiated by a write to the **TXxREG**. The value of data written to **TXxREG** will be ignored and all '0's will be transmitted.

The **SENDB** bit is automatically reset by hardware after the corresponding Stop bit is sent. This allows the user to preload the transmit FIFO with the next transmit byte following the Break character (typically, the Sync character in the LIN specification).

The Transmit Shift Register Status (**TRMT**) bit indicates when the transmit operation is Active or Idle, just as it does during normal transmission. See [Figure 32-9](#) for more details.

32.3.4.1 Break and Sync Transmit Sequence

The following sequence will start a message frame header made up of a Break, followed by an auto-baud Sync byte. This sequence is typical of a LIN bus host.

1. Configure the EUSART for the desired mode.
2. Set the **TXEN** and **SENDB** bits to enable the Break sequence.
3. Load the **TXxREG** with a dummy character to initiate transmission (the value is ignored).
4. Write '55h' to **TXxREG** to load the Sync character into the transmit FIFO buffer.
5. After the Break has been sent, the **SENDB** bit is reset by hardware and the Sync character is then transmitted.

When the **TXxREG** becomes empty, as indicated by **TXxIF**, the next data byte can be written to **TXxREG**.

32.3.5 Receiving a Break Character

The EUSART module can receive a Break character in two ways.

The first method to detect a Break character uses the Framing Error (**FERR**) bit and the received data as indicated by **RCxREG**. The Baud Rate Generator is assumed to have been initialized to the expected baud rate.

A Break character has been received when all three of the following conditions are true:

- **RCxIF** bit is set

- FERR bit is set
- RCxREG = 00h

The second method uses the Auto-Wake-Up feature described in [Auto-Wake-Up on Break](#). By enabling this feature, the EUSART will sample the next two transitions on RX/DT, cause an RCxIF interrupt, and receive the next data byte followed by another interrupt.

Note that following a Break character, the user will typically want to enable the Auto-Baud Detect feature. For both methods, the user can set the [ABDEN](#) bit before placing the EUSART in Sleep mode.

Figure 32-9. Send Break Character Sequence

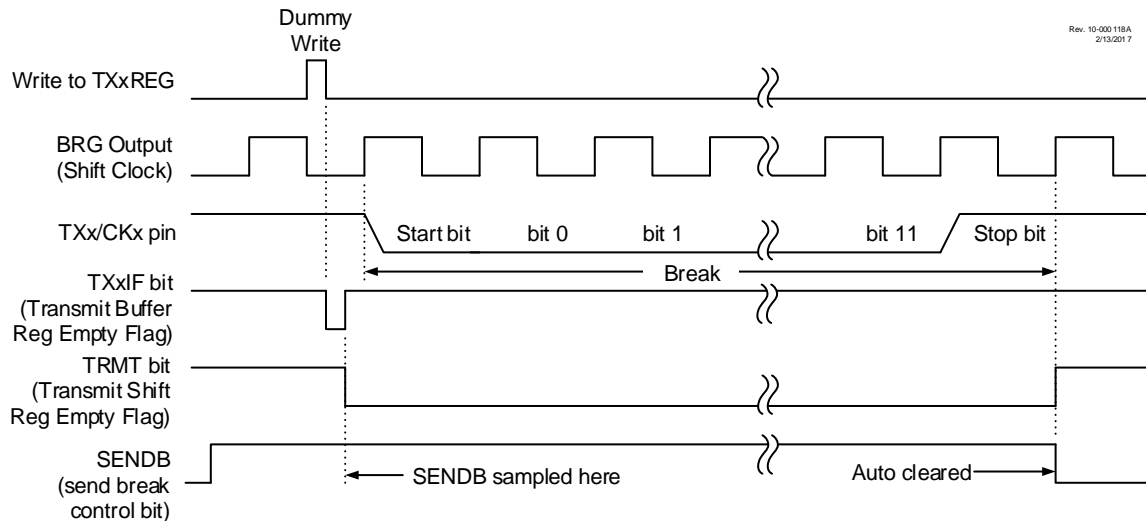

32.4 EUSART Synchronous Mode

Synchronous serial communications are typically used in systems with a single host and one or more clients. The host device contains the necessary circuitry for baud rate generation and supplies the clock for all devices in the system. Client devices can take advantage of the host clock by eliminating the internal clock generation circuitry.

There are two signal lines in Synchronous mode: A bidirectional data line (DT) and a clock line (CK). The clients use the external clock supplied by the host to shift the serial data into and out of their respective receive and transmit shift registers. Since the data line is bidirectional, synchronous operation is half-duplex only. Half-duplex refers to the fact that host and client devices can receive and transmit data but not both simultaneously. The EUSART can operate as either a host or client device.

Start and Stop bits are not used in synchronous transmissions.

32.4.1 Synchronous Host Mode

The following bits are used to configure the EUSART for synchronous host operation:

- The [SYNC](#) bit is set to '1' to configure the EUSART for synchronous operation
- The Clock Source Select ([CSRC](#)) bit is set to '1' to configure the EUSART as the host
- The Single Receive Enable ([SREN](#)) bit is set to '0' for transmit; SREN = 1 for receive (recommended setting to receive 1 byte)
- The Continuous Receive Enable ([CREN](#)) bit is set to '0' for transmit; CREN = 1 to receive continuously

- The **SPEN** bit is set to '1' to enable the EUSART interface



Important: Clearing the SREN and CREN bits ensure that the device is in the Transmit mode, otherwise the device will be configured to receive.

32.4.1.1 Host Clock

Synchronous data transfers use a separate clock line, which is synchronous with the data. A device configured as a host transmits the clock on the TX/CK line. The TXx/CKx pin output driver is automatically enabled when the EUSART is configured for synchronous transmit or receive operation. Serial data bits change on the leading edge to ensure they are valid at the trailing edge of each clock. One clock cycle is generated for each data bit. Only as many clock cycles are generated as there are data bits.

32.4.1.2 Clock Polarity

A clock polarity option is provided for Microwire compatibility. Clock polarity is selected with the Clock/Transmit Polarity Select (**SCKP**) bit. Setting the SCKP bit sets the clock Idle state as high. When the SCKP bit is set, the data changes on the falling edge of each clock. Clearing the SCKP bit sets the Idle state as low. When the SCKP bit is cleared, the data changes on the rising edge of each clock.

32.4.1.3 Synchronous Host Transmission

Data are transferred out of the device on the RXx/DTx pin. The RXx/DTx and TXx/CKx pin output drivers are automatically enabled when the EUSART is configured for synchronous host transmit operation.

A transmission is initiated by writing a character to the **TXxREG** register. If the TSR still contains all or part of a previous character the new character data are held in the TXxREG until the last bit of the previous character has been transmitted. If this is the first character, or the previous character has been completely flushed from the TSR, the data in the TXxREG is immediately transferred to the TSR. The transmission of the character commences immediately following the transfer of the data to the TSR from the TXxREG.

Each data bit changes on the leading edge of the host clock and remains valid until the subsequent leading clock edge.

Note: The TSR register is not mapped in data memory, so it is not available to the user.

32.4.1.4 Synchronous Host Transmission Setup

1. Initialize the **SPxBRGH;SPxBRGL** register pair and the **BRG16** bit to achieve the desired baud rate (see **EUSART Baud Generator (BRG)**).
2. Select the transmit output pin by writing the appropriate values to the RxyPPS register and RXxPPS register. Both selections may enable the same pin.
3. Select the clock output pin by writing the appropriate values to the RxyPPS register and TXxPPS register. Both selections may enable the same pin.
4. Enable the synchronous host serial port by setting bits **SYNC**, **SPEN** and **CSRC**.
5. Disable Receive mode by clearing the **SREN** and **CREN** bits.
6. Enable Transmit mode by setting the **TXEN** bit.
7. If 9-bit transmission is desired, set the **TX9** bit.
8. If interrupts are desired, set the TXxIE bit of the PEx register and the GIE and PEIE bits of the INTCON register.
9. If 9-bit transmission is selected, the ninth bit will be loaded in the **TX9D** bit.
10. Start transmission by loading data to the **TXxREG** register.

Figure 32-10. Synchronous Transmission

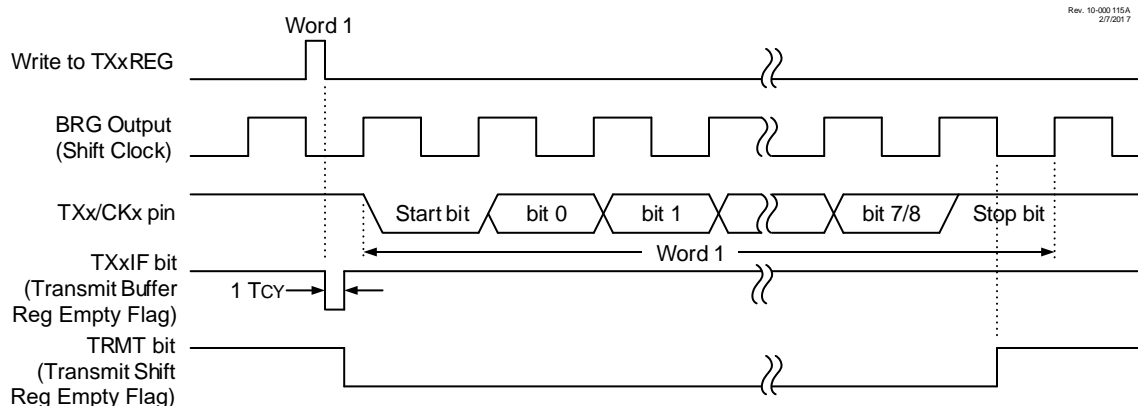

32.4.1.5 Synchronous Host Reception

Data are received at the RXx/DTx pin. The RXx/DTx pin output driver is automatically disabled when the EUSART is configured for synchronous host receive operation.

In Synchronous mode, reception is enabled by setting either the Single Receive Enable (**SREN**) bit or the Continuous Receive Enable (**CREN**) bit.

When SREN is set and CREN is clear, only as many clock cycles are generated as there are data bits in a single character. The SREN bit is automatically cleared at the completion of one character. When CREN is set, clocks are continuously generated until CREN is cleared. If CREN is cleared in the middle of a character the CK clock stops immediately and the partial character is discarded. If SREN and CREN are both set, then SREN is cleared at the completion of the first character and CREN takes precedence.

To initiate reception, set either SREN or CREN. Data are sampled at the RXx/DTx pin on the trailing edge of the TX/CK clock pin and is shifted into the Receive Shift Register (RSR). When a complete character is received into the RSR, the RCxIF bit is set and the character is automatically transferred to the two character receive FIFO. The eight Least Significant bits of the top character in the receive FIFO are available in **RCxREG**. The RCxIF bit remains set as long as there are unread characters in the receive FIFO.

Note: If the RX/DT function is on an analog pin, the corresponding ANSEL bit must be cleared for the receiver to function.

32.4.1.6 Client Clock

Synchronous data transfers use a separate clock line, which is synchronous with the data. A device configured as a client receives the clock on the TX/CK line. The TXx/CKx pin output driver is automatically disabled when the device is configured for synchronous client transmit or receive operation. Serial data bits change on the leading edge to ensure they are valid at the trailing edge of each clock. One data bit is transferred for each clock cycle. Only as many clock cycles may be received as there are data bits.



Important: If the device is configured as a client and the TX/CK function is on an analog pin, the corresponding ANSEL bit must be cleared.

32.4.1.7 Receive Overrun Error

The receive FIFO buffer can hold two characters. An overrun error will be generated if a third character, in its entirety, is received before the FIFO is accessed. When this happens the Overrun Error (**OERR**) bit is set. The characters already in the FIFO buffer can be read but no additional

characters will be received until the error is cleared. The error must be cleared by either clearing the **CREN** bit or by resetting the EUSART by clearing the **SPEN** bit.

32.4.1.8 Receiving 9-Bit Characters

The EUSART supports 9-bit character reception. When the 9-Bit Receive Enable (**RX9**) bit is set, the EUSART will shift nine bits into the RSR for each character received. The **RX9D** bit is the ninth and Most Significant data bit of the top unread character in the receive FIFO. When reading 9-bit data from the receive FIFO buffer, the **RX9D** data bit must be read before reading the eight Least Significant bits from the **RCxREG** register.

32.4.1.9 Synchronous Host Reception Setup

1. Initialize the **SPxBRGH:SPxBRGL** register pair and set or clear the **BRG16** bit, as required, to achieve the desired baud rate.
2. Select the receive input pin by writing the appropriate values to the **RxyPPS** and **RXxPPS** registers. Both selections may enable the same pin.
3. Select the clock output pin by writing the appropriate values to the **RxyPPS** and **TXxPPS** registers. Both selections may enable the same pin.
4. Clear the **ANSEL** bit for the **RXx** pin (if applicable).
5. Enable the synchronous host serial port by setting the **SYNC**, **SPEN** and **CSRC** bits.
6. Ensure that the **CREN** and **SREN** bits are cleared.
7. If interrupts are desired, set the **RCxIE** bit of the **PIEx** register and the **GIE** and **PEIE** bits of the **INTCON** register.
8. If 9-bit reception is desired, set the **RX9** bit.
9. Start reception by setting the **SREN** bit or, for continuous reception, set the **CREN** bit.
10. The **RCxIF** Interrupt Flag bit will be set when reception of a character is complete. An interrupt will be generated if the **RCxIE** enable bit was set.
11. Read the **RCxSTA** register to get the ninth bit (if enabled) and determine if any error occurred during reception.
12. Read the 8-bit received data by reading the **RCxREG** register.
13. If an overrun error occurs, clear the error by either clearing the **CREN** bit or by clearing the **SPEN** bit which resets the EUSART.

Figure 32-11. Synchronous Reception (Host Mode, SREN)

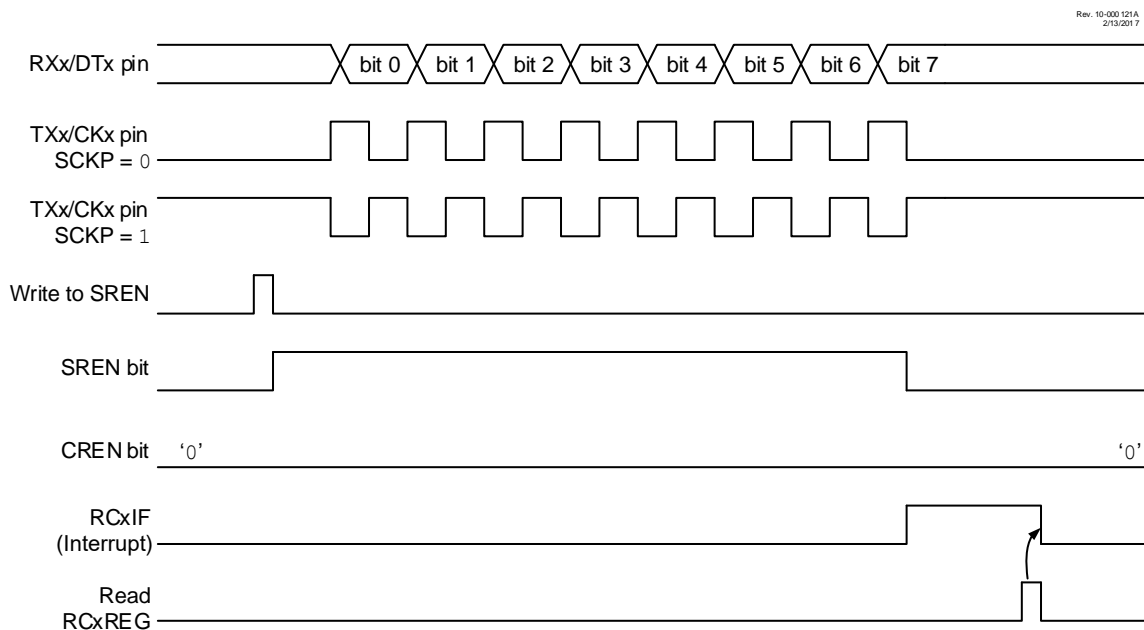

32.4.2 Synchronous Client Mode

The following bits are used to configure the EUSART for synchronous client operation:

- **SYNC** = 1 (configures the EUSART for synchronous operation)
- **CSRC** = 0 (configures the EUSART as a client)
- **SREN** = 0 (for transmit); SREN = 1 (for single byte receive)
- **CREN** = 0 (for transmit); CREN = 1 (recommended setting for continuous receive)
- **SPEN** = 1 (enables the EUSART)



Important: Clearing the SREN and CREN bits ensure that the device is in Transmit mode, otherwise the device will be configured to receive.

32.4.2.1 EUSART Synchronous Client Transmit

The operation of the Synchronous Host and Client modes are identical (see [Synchronous Host Transmission](#)), except in the case of the Sleep mode.

If two words are written to the **TXxREG** and then the **SLEEP** instruction is executed, the following will occur:

1. The first character will immediately transfer to the TSR register and transmit.
2. The second word will remain in the TXxREG register.
3. The TXxIF bit will not be set.
4. After the first character has been shifted out of TSR, the TXxREG register will transfer the second character to the TSR and the TXxIF bit will now be set.
5. If the PEIE and TXxIE bits are set, the interrupt will wake the device from Sleep and execute the next instruction. If the GIE bit is also set, the program will call the Interrupt Service Routine.

32.4.2.2 Synchronous Client Transmission Setup

1. Set the **SYNC** and **SPEN** bits and clear the **CSRC** bit.
2. Select the transmit output pin by writing the appropriate values to the RxyPPS register and RXxPPS register. Both selections may enable the same pin.
3. Select the clock input pin by writing the appropriate value to the TXxPPS register.
4. Clear the ANSEL bit for the CKx pin (if applicable).
5. Clear the **CREN** and **SREN** bits.
6. If interrupts are desired, set the TXxIE bit of the PEx register and the GIE and PEIE bits of the INTCON register.
7. If 9-bit transmission is desired, set the **TX9** bit.
8. Enable transmission by setting the **TXEN** bit.
9. If 9-bit transmission is selected, insert the Most Significant bit into the **TX9D** bit.
10. Prepare for transmission by writing the eight Least Significant bits to the **TXxREG** register. The word will be transmitted in response to the Host clocks at the CKx pin.

32.4.2.3 EUSART Synchronous Client Reception

The operation of the Synchronous Host and Client modes is identical (see [Synchronous Host Reception](#)), with the following exceptions:

- Sleep
- **CREN** bit is always set, therefore the receiver is never Idle
- **SREN** bit, which is a “don’t care” in Client mode

A character may be received while in Sleep mode by setting the CREN bit prior to entering Sleep. Once the word is received, the RSR register will transfer the data to the **RCxREG** register. If the RCxIE enable bit is set, the interrupt generated will wake the device from Sleep and execute the next instruction. If the GIE bit is also set, the program will branch to the interrupt vector.

32.4.2.4 Synchronous Client Reception Setup

1. Set the **SYNC** and **SPEN** bits and clear the **CSRC** bit.
2. Select the receive input pin by writing the appropriate value to the RXxPPS register.
3. Select the clock input pin by writing the appropriate values to the TXxPPS register.
4. Clear the ANSEL bit for both the TXx/CKx and RXx/DTx pins (if applicable).
5. If interrupts are desired, set the RCxIE bit of the PEx register and the GIE and PEIE bits of the INTCON register.
6. If 9-bit reception is desired, set the **RX9** bit.
7. Set the **CREN** bit to enable reception.
8. The RCxIF bit will be set when reception is complete. An interrupt will be generated if the RCxIE bit was set.
9. If 9-bit mode is enabled, retrieve the Most Significant bit from the **RX9D** bit.
10. Retrieve the eight Least Significant bits from the receive FIFO by reading the **RCxREG** register.
11. If an overrun error occurs, clear the error by either clearing the CREN bit or by clearing the SPEN bit which resets the EUSART.

32.5 EUSART Operation During Sleep

The EUSART will remain active during Sleep only in the Synchronous Client mode. All other modes require the system clock and therefore cannot generate the necessary signals to run the Transmit or Receive Shift registers during Sleep.

Synchronous Client mode uses an externally generated clock to run the Transmit and Receive Shift registers.

32.5.1 Synchronous Receive During Sleep

To receive during Sleep, all the following conditions must be met before entering Sleep mode:

- [RCxSTA](#) and [TXxSTA](#) Control registers must be configured for Synchronous Client Reception (see [Synchronous Client Reception Setup](#)).
- If interrupts are desired, set the RCxIE bit of the PIEx register and the GIE and PEIE bits of the INTCON register.
- The RCxIF interrupt flag must be cleared by reading [RCxREG](#) to unload any pending characters in the receive buffer.

Upon entering Sleep mode, the device will be ready to accept data and clocks on the RXx/DTx and TXx/CKx pins, respectively. When the data word has been completely clocked in by the external device, the RCxIF Interrupt Flag bit of the PIRx register will be set. Thereby, waking the processor from Sleep.

Upon waking from Sleep, the instruction following the `SLEEP` instruction will be executed. If the Global Interrupt Enable (GIE) bit of the INTCON register is also set, then the Interrupt Service Routine (ISR) will be called.

32.5.2 Synchronous Transmit During Sleep

To transmit during Sleep, the following conditions must be met before entering Sleep mode:

- The [RCxSTA](#) and [TXxSTA](#) Control registers must be configured for synchronous client transmission (see [Synchronous Client Transmission Setup](#)).
- The TXxIF interrupt flag must be cleared by writing the output data to the [TXxREG](#), thereby filling the TSR and transmit buffer.
- The TXxIE interrupt enable bits of the PIEx register and PEIE of the INTCON register must be written to '1'.
- If interrupts are desired, set the GIE bit of the INTCON register.

Upon entering Sleep mode, the device will be ready to accept clocks on the TXx/CKx pin and transmit data on the RXx/DTx pin. When the data word in the TSR register has been completely clocked out by the external device, the pending byte in the TXxREG will transfer to the TSR and the TXxIF flag will be set. Thereby, waking the processor from Sleep. At this point, the TXxREG is available to accept another character for transmission. Writing TXxREG will clear the TXxIF flag.

Upon waking from Sleep, the instruction following the `SLEEP` instruction will be executed. If the Global Interrupt Enable (GIE) bit is also set then the Interrupt Service Routine (ISR) will be called.

32.6 Register Definitions: EUSART Control

32.6.1 TXxSTA

Name: TXxSTA
Offset: 0x0711,0x071B

Transmit Status and Control Register

Bit	7	6	5	4	3	2	1	0
	CSRC	TX9	TXEN	SYNC	SENDB	BRGH	TRMT	TX9D
Access	R/W	R/W	R/W	R/W	R/W	R/W	R	R/W
Reset	0	0	0	0	0	0	1	0

Bit 7 – CSRC Clock Source Select

Value	Condition	Description
1	SYNC = 1	Host mode (clock generated internally from BRG)
0	SYNC = 1	Client mode (clock from external source)
X	SYNC = 0	Don't care

Bit 6 – TX9 9-Bit Transmit Enable

Value	Description
1	Selects 9-bit transmission
0	Selects 8-bit transmission

Bit 5 – TXEN Transmit Enable Enables transmitter⁽¹⁾

Value	Description
1	Transmit enabled
0	Transmit disabled

Bit 4 – SYNC EUSART Mode Select

Value	Description
1	Synchronous mode
0	Asynchronous mode

Bit 3 – SENDB Send Break Character

Value	Condition	Description
1	SYNC = 0	Send Sync Break on next transmission (cleared by hardware upon completion)
0	SYNC = 0	Sync Break transmission disabled or completed
X	SYNC = 1	Don't care

Bit 2 – BRGH High Baud Rate Select

Value	Condition	Description
1	SYNC = 0	High speed, if BRG16 = 1, baud rate is baudclk/4; else baudclk/16
0	SYNC = 0	Low speed
X	SYNC = 1	Don't care

Bit 1 – TRMT Transmit Shift Register (TSR) Status

Value	Description
1	TSR is empty
0	TSR is not empty

Bit 0 – TX9D Ninth Bit of Transmit Data Can be address/data bit or a parity bit.

Note: 1. The [SREN](#) and [CREN](#) bits override TXEN in Sync mode.

32.6.2 RCxSTA

Name: RCxSTA
Offset: 0x0710,0x071A

Receive Status and Control Register

Bit	7	6	5	4	3	2	1	0
	SPEN	RX9	SREN	CREN	ADDEN	FERR	OERR	RX9D
Access	R/W	R/W	R/W/HC	R/W	R/W	R	R/HC	R/HC
Reset	0	0	0	0	0	0	0	0

Bit 7 – SPEN Serial Port Enable

Value	Description
1	Serial port enabled
0	Serial port disabled (held in Reset)

Bit 6 – RX9 9-Bit Receive Enable

Value	Description
1	Selects 9-bit reception
0	Selects 8-bit reception

Bit 5 – SREN Single Receive Enable

Controls reception. This bit is cleared by hardware when reception is complete

Value	Condition	Description
1	SYNC = 1 AND CSRC = 1	Start single receive
0	SYNC = 1 AND CSRC = 1	Single receive is complete
x	SYNC = 0 OR CSRC = 0	Don't care

Bit 4 – CREN Continuous Receive Enable

Value	Condition	Description
1	SYNC = 1	Enables continuous receive until enable bit CREN is cleared (CREN overrides SREN)
0	SYNC = 1	Disables continuous receive
1	SYNC = 0	Enables receiver
0	SYNC = 0	Disables receiver

Bit 3 – ADDEN Address Detect Enable

Value	Condition	Description
1	SYNC = 0 AND RX9 = 1	The receive buffer is loaded and the interrupt occurs only when the ninth received bit is set
0	SYNC = 0 AND RX9 = 1	All bytes are received and interrupt always occurs. Ninth bit can be used as parity bit
x	RX9 = 0 OR SYNC = 1	Don't care

Bit 2 – FERR Framing Error

Value	Description
1	Unread byte in RCxREG has a framing error
0	Unread byte in RCxREG does not have a framing error

Bit 1 – OERR Overrun Error

Value	Description
1	Overrun error (can be cleared by clearing either SPEN or CREN bit)
0	No overrun error

Bit 0 – RX9D Ninth bit of Received Data

This can be address/data bit or a parity bit which is determined by user firmware.

32.6.3 BAUDxCON

Name: BAUDxCON
Offset: 0x0712,0x071C

Baud Rate Control Register

Bit	7	6	5	4	3	2	1	0
	ABDOVF	RCIDL		SCKP	BRG16		WUE	ABDEN
Access	R	R		R/W	R/W		R/W	R/W
Reset	0	1		0	0		0	0

Bit 7 – ABDOVF Auto-Baud Detect Overflow

Value	Condition	Description
1	SYNC = 0	Auto-baud timer overflowed
0	SYNC = 0	Auto-baud timer did not overflow
X	SYNC = 1	Don't care

Bit 6 – RCIDL Receive Idle Flag

Value	Condition	Description
1	SYNC = 0	Receiver is Idle
0	SYNC = 0	Start bit has been received and the receiver is receiving
X	SYNC = 1	Don't care

Bit 4 – SCKP Clock/Transmit Polarity Select

Value	Condition	Description
1	SYNC = 0	Idle state for transmit (TX) is a low level (transmit data are inverted)
0	SYNC = 0	Idle state for transmit (TX) is a high level (transmit data are non-inverted)
1	SYNC = 1	Data are clocked on rising edge of the clock
0	SYNC = 1	Data are clocked on falling edge of the clock

Bit 3 – BRG16 16-bit Baud Rate Generator Select

Value	Description
1	16-bit Baud Rate Generator is used
0	8-bit Baud Rate Generator is used

Bit 1 – WUE Wake-Up Enable

Value	Condition	Description
1	SYNC = 0	Receiver is waiting for a falling edge. Upon falling edge, no character will be received and the RCxIF flag will be set. WUE will automatically clear after RCxIF is set.
0	SYNC = 0	Receiver is operating normally
X	SYNC = 1	Don't care

Bit 0 – ABDEN Auto-Baud Detect Enable

Value	Condition	Description
1	SYNC = 0	Auto-Baud Detect mode is enabled (clears when auto-baud is complete)
0	SYNC = 0	Auto-Baud Detect is complete or mode is disabled
X	SYNC = 1	Don't care

32.6.4 RCxREG

Name: RCxREG
Offset: 0x070C,0x0716

Receive Data Register

Bit	7	6	5	4	3	2	1	0
	RCREG[7:0]							
Access	R	R	R	R	R	R	R	R
Reset	0	0	0	0	0	0	0	0

Bits 7:0 – RCREG[7:0] Receive data

32.6.5 TXxREG

Name: TXxREG
Offset: 0x070D,0x0717

Transmit Data Register

Bit	7	6	5	4	3	2	1	0
	TXREG[7:0]							
Access	R/W	R/W	R/W	R/W	R/W	R/W	R/W	R/W
Reset	0	0	0	0	0	0	0	0

Bits 7:0 – TXREG[7:0] Transmit Data

32.6.6 SPxBRG

Name: SPxBRG
Offset: 0x070E,0x0718

EUSART Baud Rate Generator

Bit	15	14	13	12	11	10	9	8
	SPBRG[15:8]							
Access	R/W	R/W	R/W	R/W	R/W	R/W	R/W	R/W
Reset	0	0	0	0	0	0	0	0
Bit	7	6	5	4	3	2	1	0
	SPBRG[7:0]							
Access	R/W	R/W	R/W	R/W	R/W	R/W	R/W	R/W
Reset	0	0	0	0	0	0	0	0

Bits 15:0 – SPBRG[15:0] Baud Rate Register

Notes: The individual bytes in this multibyte register can be accessed with the following register names:

- SPxBRGH: Accesses the high byte SPBRG[15:8]
- SPxBRGL: Accesses the low byte SPBRG[7:0]

32.7 Register Summary - EUSART

Offset	Name	Bit Pos.	7	6	5	4	3	2	1	0
0x00	Reserved									
...										
0x070B										
0x070C	RC1REG	7:0	RCREG[7:0]							
0x070D	TX1REG	7:0	TXREG[7:0]							
0x070E	SP1BRG	7:0	SPBRG[7:0]							
		15:8	SPBRG[15:8]							
0x0710	RC1STA	7:0	SPEN	RX9	SREN	CREN	ADDEN	FERR	OERR	RX9D
0x0711	TX1STA	7:0	CSRC	TX9	TXEN	SYNC	SENDB	BRGH	TRMT	TX9D
0x0712	BAUD1CON	7:0	ABDOVF	RCIDL		SCKP	BRG16		WUE	ABDEN
0x0713	Reserved									
...										
0x0715										
0x0716	RC2REG	7:0	RCREG[7:0]							
0x0717	TX2REG	7:0	TXREG[7:0]							
0x0718	SP2BRG	7:0	SPBRG[7:0]							
		15:8	SPBRG[15:8]							
0x071A	RC2STA	7:0	SPEN	RX9	SREN	CREN	ADDEN	FERR	OERR	RX9D
0x071B	TX2STA	7:0	CSRC	TX9	TXEN	SYNC	SENDB	BRGH	TRMT	TX9D
0x071C	BAUD2CON	7:0	ABDOVF	RCIDL		SCKP	BRG16		WUE	ABDEN

33. ADC - Analog-to-Digital Converter with Computation Module

The Analog-to-Digital Converter with Computation module allows conversion of both single-ended and differential analog input signals to a 12-bit binary representation of that signal. This device uses analog inputs that are multiplexed into a single Sample-and-Hold circuit. The output of the Sample-and-Hold (S/H) circuit is connected to the input of the converter. The converter generates a 12-bit binary result via successive approximation and stores the conversion result into the ADC result registers. In single-ended conversions, the ADC measures the voltage between the selected analog input and V_{SS} (0V). In differential conversions, the ADC measures the voltage difference between two selected analog inputs. The selected ADC input channels can either be from an internal source, such as the Fixed Voltage Reference (FVR), or from external analog input pins. Additionally, the following features are provided within the ADC module:

- Acquisition Timer
- Hardware Capacitive Voltage Divider (CVD) Support:
 - Precharge timer
 - Adjustable Sample-and-Hold capacitor array
 - Guard ring digital output drive
- Automatic Repeat and Sequencing:
 - Automated double sample conversion for CVD
 - Two sets of Result registers (Current Result and Previous Result)
 - Auto-conversion trigger
 - Internal retrigger
- Channel Grouping:
 - Allows multiple input channels to be grouped together into a single input channel
- Computation Features:
 - Averaging and low-pass filter functions
 - Reference comparison
 - 2-level threshold comparison
 - Selectable interrupts

Figure 33-1 shows the block diagram of the ADC.

The ADC positive voltage reference is software selectable to be either internally generated or externally supplied. The ADC negative voltage reference is internally connected to V_{SS} .

The ADC can generate an interrupt upon completion of a conversion and upon threshold comparison. These interrupts can be used to wake up the device from Sleep.

Figure 33-1. ADC Block Diagram

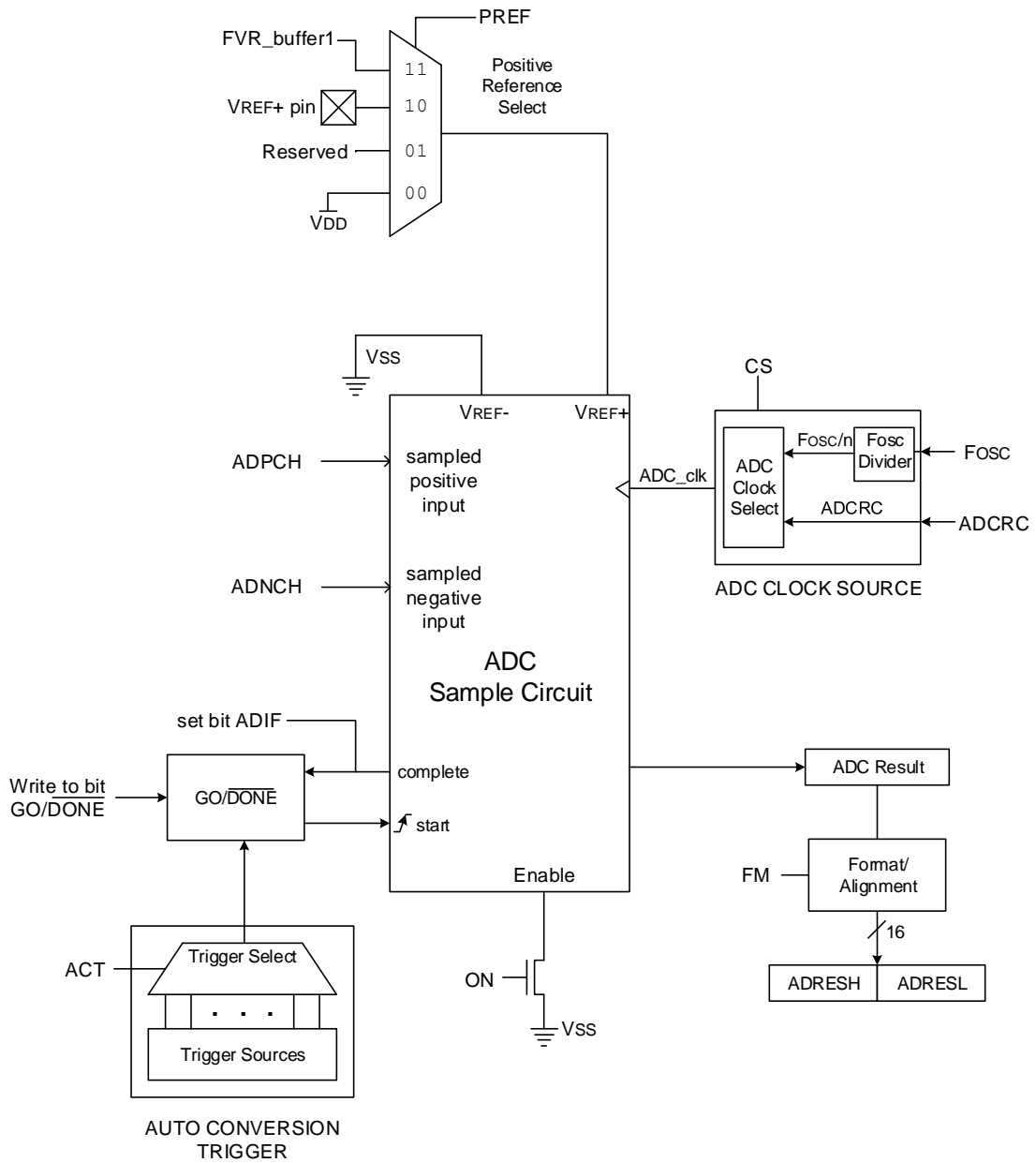

Positive/Negative Input Selection Multiplexers

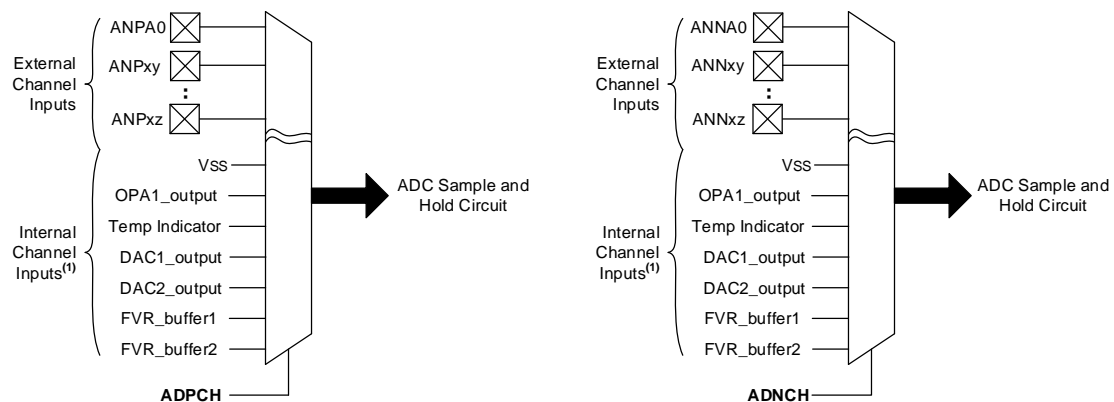

Note 1: The internal input channel selections vary. The inputs shown are all possible input selections. Please refer to the “ADC Positive Input Channel Selection” and “ADC Negative Input Channel Selection” tables for device-specific selection options.

33.1 ADC Configuration

When configuring the ADC the following functions must be considered:

- ADC Input Configuration
- Port Configuration
- Channel Selection
- ADC Voltage Reference Selection
- ADC Conversion Clock Source
- Interrupt Control
- Result Formatting
- Conversion Trigger Selection
- ADC Acquisition Time
- ADC Precharge Time
- Additional Sample-and-Hold Capacitor
- Single/Double Sample Conversion
- Guard Ring Outputs

33.1.1 ADC Input Configuration

The ADC Input Configuration (IC) bit is used to determine whether the ADC uses both positive and negative input channels in differential operations or only the positive input channel in single-ended operations.

When IC is set (IC = 1), the ADC operates in Differential mode. In Differential mode, the ADC calculates the difference between a positive analog input signal and a negative analog input signal with respect to the ADC reference voltage (V_{REF}), and the conversion result may be a positive or negative value. The positive input signal is selected by the ADC Positive Channel Selection (ADPCH) register, and the negative input signal is selected by the ADC Negative Channel Selection (ADNCH)

register. The ADC reference voltage (V_{REF}) is the difference between the ADC Positive Voltage Reference (V_{REF+}) input and V_{SS} .

Equation 33-1. Differential Conversion Result

$$\text{Conversion result} = \frac{IN_{ADPCH} - IN_{ADNCH}}{V_{REF+} - V_{REF-}}$$

When IC is clear ($IC = 0$), the ADC operates in Single-Ended mode. In Single-Ended mode, the ADC converts the positive input signal with respect to V_{REF} , and the conversion result will be a positive value. The positive input is selected by ADPCH, similar to Differential mode; however, in Single-Ended mode, ADC hardware ignores any negative input selections selected by ADNCH. In Single-Ended mode, V_{REF} is the difference between V_{REF+} and V_{SS} .

Equation 33-2. Single-Ended Conversion Result

$$\text{Conversion result} = \frac{IN_{ADPCH}}{V_{REF+} - V_{SS}}$$

33.1.2 Port Configuration

The ADC will convert the voltage level on a pin, whether or not the ANSEL bit is set. When converting analog signals, the I/O pin may be configured for analog by setting the associated TRIS and ANSEL bits. Refer to the “**I/O Ports**” chapter for more information.



Important: Analog voltages on any pin defined as a digital input may cause the input buffer to conduct excess current.

33.1.3 Channel Selection

The ADPCH and ADNCH registers determine which input channels are connected to the Sample-and-Hold circuit for conversion. When switching channels, it is recommended to have some acquisition time (ADACQ register) before starting the next conversion. Refer to the [ADC Operation](#) section for more information.



Important: To reduce the chance of measurement error, it is recommended to discharge the Sample-and-Hold capacitor when switching between ADC channels by starting a conversion on a channel connected to V_{SS} and terminating the conversion after the acquisition time has elapsed. If the ADC does not have a dedicated V_{SS} input channel, the V_{SS} selection through the DAC output channel can be used. If the DAC is in use (or the device does not have a DAC), a free input channel can be connected to V_{SS} and can be used in place of the DAC.

33.1.3.1 Channel Grouping

Channel grouping allows multiple, simultaneous input connections to the ADC. The ADC Channel Group Selection (ADCGx, x = Group number, p = PORT) registers are used to enable each I/O port's analog input channels. A channel group includes all enabled inputs from each of the group's selection registers. All of the group's input signals are wire-OR'd into a single ADC positive input channel, ADCGx, which can be selected by the ADC Positive Input Channel Selection (PCH) bits.

The example below illustrates the configuration of one channel group.

Example 33-1. ADC Group Example (20-Pin Device)

```

ADCG1A = 0x05;    // Include ANA0 and ANA2 in Group 1
ADCG1B = 0xB0;    // Include ANB4, ANB6, and ANB7 in Group 1
ADCG1C = 0x0A;    // Include ANC1 and ANC3 in Group 1

```

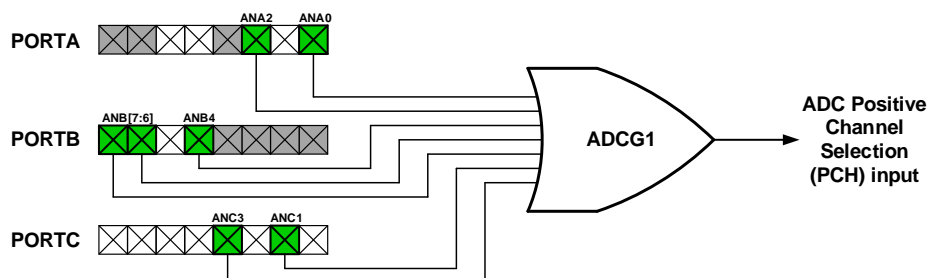
**33.1.4 ADC Voltage Reference**

The **PREF** bits provide control of the positive voltage reference. Refer to the **ADREF** register for the list of available positive sources.

33.1.5 Conversion Clock

The conversion clock source is selected with the **CS** bit. When **CS** = 1, the ADC clock source is an internal fixed-frequency clock referred to as **ADCRC**. When **CS** = 0, the ADC clock source is derived from F_{osc} .



Important: When **CS** = 0, the clock can be divided using the **ADCLK** register to meet the ADC clock period requirements.

The time to complete one bit conversion is defined as the T_{AD} . Refer to **Figure 33-2** for the complete timing details of the ADC conversion.

For correct conversion, the appropriate T_{AD} specification must be met. Refer to the ADC Timing Specifications table in the **“Electrical Specifications”** chapter of the device data sheet for more details. The table below gives examples of appropriate ADC clock selections.

Table 33-1. ADC Clock Period (T_{AD}) vs. Device Operating Frequencies^(3,5)

ADC Clock Source	ADCLK ⁽²⁾	ADC Clock Period (T_{AD}) for Different Device Frequency (F_{osc})					
		32 MHz ⁽¹⁾	20 MHz ⁽¹⁾	16 MHz ⁽¹⁾	8 MHz	4 MHz	1 MHz
$F_{osc}/2$	<code>\b000000(2)</code>	62.5 ns ⁽⁴⁾	100 ns ⁽⁴⁾	125 ns ⁽⁴⁾	250 ns ⁽⁴⁾	500 ns ⁽⁴⁾	2.0 μ s
$F_{osc}/4$	<code>\b000001</code>	125 ns ⁽⁴⁾	200 ns ⁽⁴⁾	250 ns ⁽⁴⁾	500 ns ⁽⁴⁾	1.0 μ s	4.0 μ s
$F_{osc}/6$	<code>\b000010(2)</code>	187.5 ns ⁽⁴⁾	300 ns ⁽⁴⁾	375 ns ⁽⁴⁾	750 ns ⁽⁴⁾	1.5 μ s	6.0 μ s
$F_{osc}/8$	<code>\b000011</code>	250 ns ⁽⁴⁾	400 ns ⁽⁴⁾	500 ns ⁽⁴⁾	1.0 μ s	2.0 μ s	8.0 μ s
...
$F_{osc}/16$	<code>\b000111</code>	500 ns ⁽⁴⁾	800 ns ⁽⁴⁾	1.0 μ s	2.0 μ s	4.0 μ s	16.0 μ s ⁽⁴⁾
...

.....continued

ADC Clock Source	ADCLK ⁽²⁾	ADC Clock Period (T_{AD}) for Different Device Frequency (F_{OSC})					
		32 MHz ⁽¹⁾	20 MHz ⁽¹⁾	16 MHz ⁽¹⁾	8 MHz	4 MHz	1 MHz
$F_{OSC}/32$	\`b0011111	1.0 μ s	1.6 μ s	2.0 μ s	4.0 μ s	8.0 μ s	32.0 μ s ⁽⁴⁾
...
$F_{OSC}/64$	\`b01111111	2.0 μ s	3.2 μ s	4.0 μ s	8.0 μ s	16.0 μ s ⁽⁴⁾	64.0 μ s ⁽⁴⁾
...
$F_{OSC}/128$	\`b1111111	4.0 μ s	6.4 μ s	8.0 μ s	16.0 μ s ⁽⁴⁾	32.0 μ s ⁽⁴⁾	128.0 μ s ⁽⁴⁾
ADCRC	CS = 1	1.0-6.0 μ s	1.0-6.0 μ s	1.0-6.0 μ s	1.0-6.0 μ s	1.0-6.0 μ s	1.0-6.0 μ s

Notes:

- Frequencies above 8 MHz are not recommended when using F_{OSC} as the clock source.
- For accurate ADC results, loading the ADCLK register with even-numbered values (e.g. 0x00, 0x02, 0x04, etc.) is not recommended.
- Refer to the "**Electrical Specifications**" chapter of the device data sheet to see the T_{AD} parameter for the ADCRC source typical T_{AD} value.
- These values violate the required T_{AD} time.
- The ADC clock period (T_{AD}) and total ADC conversion time can be minimized when the ADC clock is derived from the system clock F_{OSC} . However, the ADCRC oscillator source must be used when conversions are to be performed with the device in Sleep mode.

**Important:**

- Except for the ADCRC clock source, any changes in the system clock frequency will change the ADC clock frequency, which may adversely affect the ADC result.
- The internal control logic of the ADC runs off of the clock selected by the CS bit. When the CS bit is set to '1' (ADC runs on ADCRC), there may be unexpected delays in operation when setting the ADC control bits.

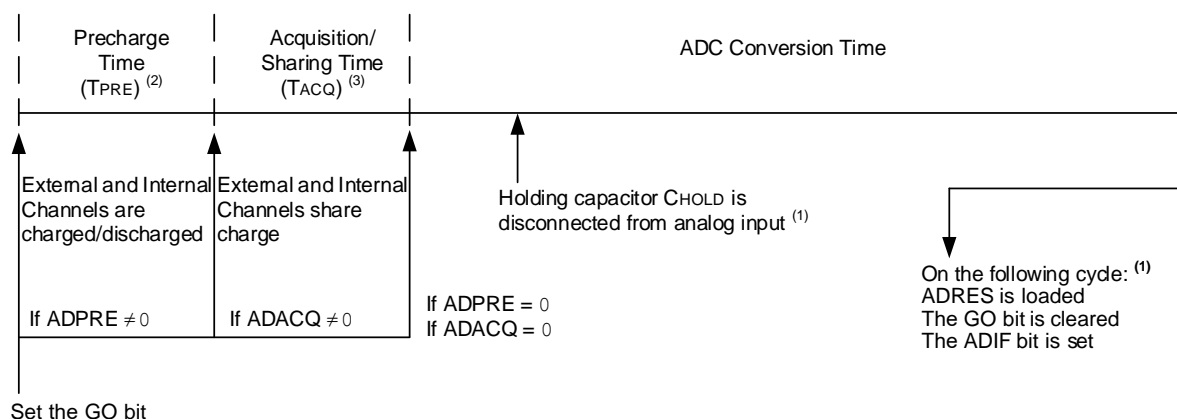
Figure 33-2. Analog-to-Digital Conversion Cycles**Notes:**

- Refer to the ADC Conversion Timing Specifications table in the "**Electrical Specifications**" chapter of the device data sheet for more details.
- Refer to the ADPRE register for more details.
- Refer to the ADACQ register for more details.

33.1.6 Interrupts

The ADC module allows for the ability to generate an interrupt upon completion of an Analog-to-Digital Conversion. The ADC interrupt flag is the ADIF bit in the PIRx register. The ADC interrupt enable is the ADIE bit in the PIRx register. The ADIF bit must be cleared by software.

**Important:**

1. The ADIF bit is set at the completion of every conversion, regardless of whether or not the ADC interrupt is enabled.
2. The ADC operates during Sleep only when the ADCRC oscillator is selected.

The ADC Interrupt can be generated while the device is operating or while in Sleep. While the device is operating in Sleep mode:

- If ADIE = 1, PEIE = 1, and GIE = 0: An interrupt will wake the device from Sleep. Upon waking from Sleep, the instructions following the SLEEP instruction are executed. The Interrupt Service Routine is not executed.
- If ADIE = 1, PEIE = 1, and GIE = 1: An interrupt will wake the device from Sleep. Upon waking from Sleep, the instruction following the SLEEP instruction is always executed. Then the execution will switch to the Interrupt Service Routine.

33.1.7 Result Formatting

The ADC Results Format/Alignment Selection (FM) and the ADC Input Configuration (IC) bits are used to determine the format and alignment of the conversion result.

When IC = '0' and FM = 'x0', the conversion result is left justified, as shown in Figure 33-3.

Figure 33-3. 12-Bit ADC Conversion Result Alignment/Format: IC = 0, FM = x0

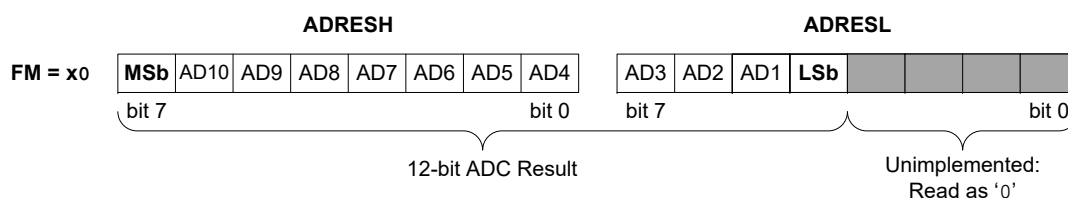

When IC = '0' and FM = 'x1', the conversion result is right justified, as shown in Figure 33-4.

Figure 33-4. 12-Bit ADC Conversion Result Alignment/Format: IC = 0, FM = x1

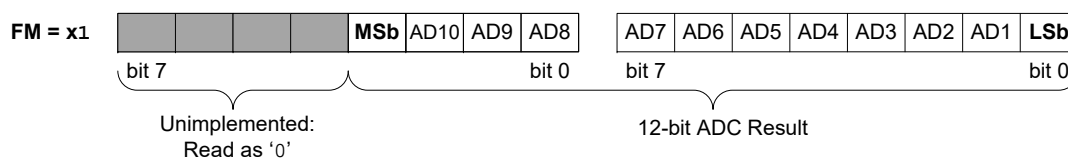

When IC = '1' and FM = '00', the conversion result is in left justified alignment and Two's Complement format, as shown in Figure 33-5.

Figure 33-5. 12-Bit ADC Conversion Result Alignment/Format: IC = 1, FM = 00

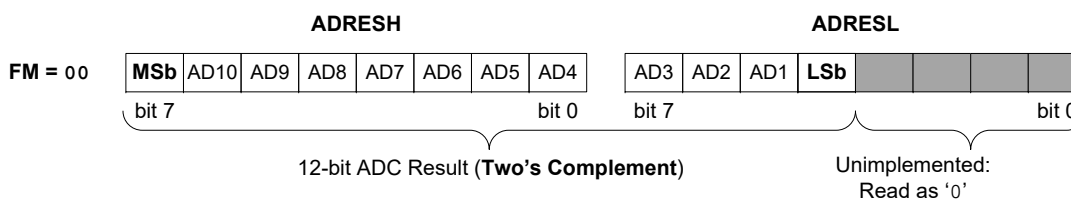

When IC = '1' and FM = '01', the conversion result is in right justified alignment and Two's Complement format, as shown in Figure 33-6.

Figure 33-6. 12-Bit ADC Conversion Result Alignment/Format: IC = 1, FM = 01

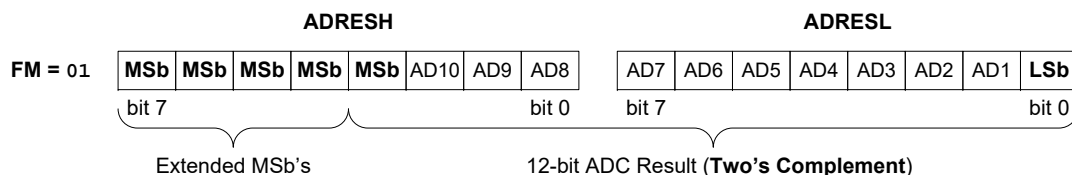

When IC = '1' and FM = '10', the conversion result is in left justified alignment and sign/magnitude format, as shown in Figure 33-7.

Figure 33-7. 12-Bit ADC Conversion Result Alignment/Format: IC = 1, FM = 10

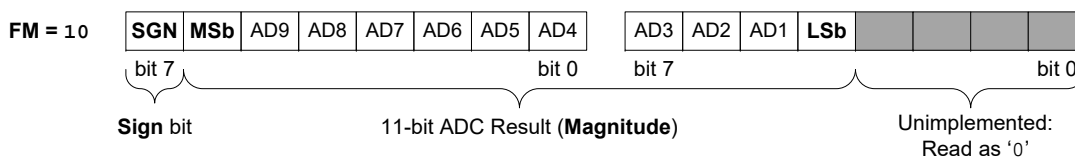

When IC = '1' and FM = '11', the conversion result is in right justified alignment and sign/magnitude format, as shown in Figure 33-8.

Figure 33-8. 12-Bit ADC Conversion Result Alignment/Format: IC = 1, FM = 11

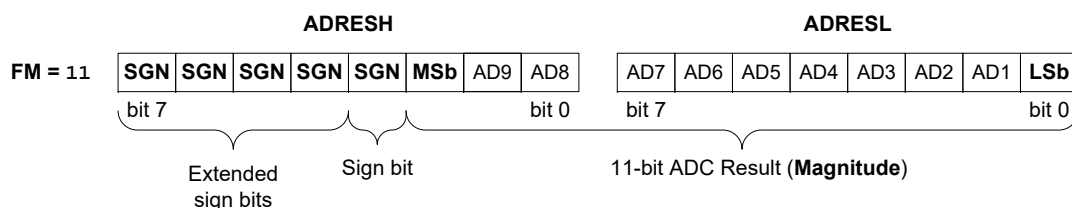

Important: Writes to the ADRES register pair are always right justified, regardless of the selected format mode. Therefore, a data read after writing to ADRES when FM = 00 or 10 will be shifted left three places.

33.1.7.1 Sign/Magnitude and Two's Complement Result

When performing differential measurements, the conversion results can be presented in either a sign/magnitude or two's complement format.

In sign/magnitude format, the conversion result is a binary representation of the input, with a sign bit determining the polarity. Equation 33-3 can be used to calculate the full-scale range of ADC result values in sign/magnitude format:

Equation 33-3. ADC Range in Sign/Magnitude Result Format

$$n\text{-bit range in sign/magnitude format} = \pm 2^{n-1} - 1$$

where:

n = ADC resolution

Examples:

$$12\text{-bit ADC} = \pm 2^{12-1} - 1 = \pm 2047$$

In [Example 33-2](#), the right justified ADRES value is '0x8020'. The 11-bit sign/magnitude formatted result shows an absolute value of '2' (decimal), with bit 7 of the ADRESH register representing the sign bit. When the sign bit = '0', the result is positive, and when the sign bit = '1', the result is negative. For this example, the sign bit = '1', so the sign/magnitude formatted decimal result value is '-2'.

Example 33-2. 12-Bit Sign/Magnitude Result Format

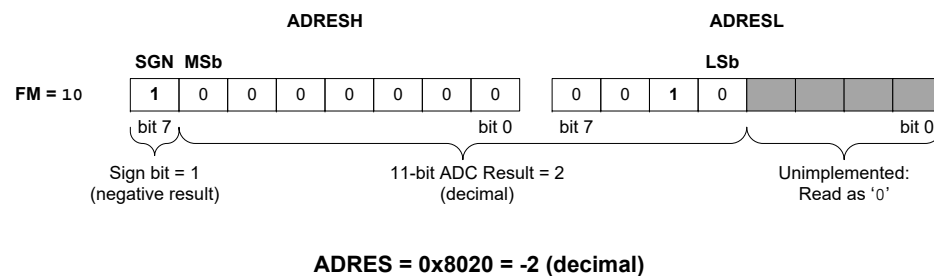

In two's complement format, the MSb of the conversion result determines the polarity. [Equation 33-4](#) can be used to calculate the full-scale range of ADC result values in two's complement format:

Equation 33-4. ADC Range in Two's Complement Result Format

$$n\text{-bit range in two's complement format} = (-2^{n-1} - 1), (2^{n-1} - 2)$$

where:

n = ADC resolution

Example:

$$\begin{aligned} 12\text{-bit ADC} &= (-2^{12-1} - 1) = -2047 \text{ (low range)} \\ &= (2^{12-1} - 2) = 2046 \text{ (high range)} \end{aligned}$$

In [Example 33-3](#), the right justified ADRES result is '0x8020', which matches the ADRES result in [Example 33-2](#). The 12-bit two's complement result shows a value of '-2046' (decimal), with bit 7 of the ADRESH register representing the MSb of the conversion result.

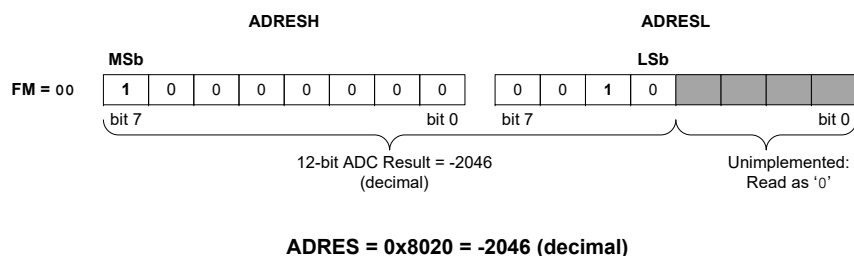
Example 33-3. 12-Bit Two's Complement Result Format

33.2 ADC Operation

33.2.1 Starting a Conversion

To enable the ADC module, the **ON** bit must be set to '1'. A conversion may be started by any of the following:

- Software setting the **GO** bit to '1'
- An external trigger (source selected by **ADACT**)
- A Continuous-mode retrigger (see the [Continuous Sampling Mode](#) section for more details)



Important: The **GO** bit must not be set in the same instruction that turns on the ADC. Refer to the [ADC Conversion Procedure \(Basic Mode\)](#) section for more details.

33.2.2 Completion of a Conversion

When any individual conversion is complete, the existing value in **ADRES** is written into **ADPREV** (if **PSIS** = 0) and the new conversion results appear in **ADRES**. When the conversion completes, the ADC module will:

- Clear the **GO** bit (unless the **CONT** bit is set)
- Set the **ADIF** Interrupt Flag bit
- Set the **MATH** bit
- Update **ADACC**

After every conversion when **DSEN** = 0 or after every other conversion when **DSEN** = 1, the following events occur:

- **ADERR** is calculated
- ADC Channel Threshold Interrupt (**ADTIF**) is set if **ADERR** calculation meets threshold comparison

33.2.3 ADC Operation During Sleep

The ADC module can operate during Sleep. This requires the ADC clock source to be set to the **ADCRC** option. When the **ADCRC** oscillator source is selected, the ADC waits one additional instruction before starting the conversion. This allows the **SLEEP** instruction to be executed, which can reduce system noise during the conversion. If the ADC interrupt is enabled, the device will wake up from Sleep when the conversion completes. If the ADC interrupt is disabled, the device remains

in Sleep and the ADC module is turned off after the conversion completes, although the **ON** bit remains set.

33.2.4 External Trigger During Sleep

If the external trigger is received during Sleep while the ADC clock source is set to the ADCRC, the ADC module will perform the conversion and set the ADIF bit upon completion.

If an external trigger is received when the ADC clock source is something other than ADCRC, the trigger will be recorded, but the conversion will not begin until the device exits Sleep.

33.2.5 Auto-Conversion Trigger

The auto-conversion trigger allows periodic ADC measurements without software intervention. When a rising edge of the selected source occurs, the **GO** bit is set by hardware.

The auto-conversion trigger source is selected with the **ACT** bits.

Using the auto-conversion trigger does not ensure proper ADC timing. It is the user's responsibility to ensure that the ADC timing requirements are met.

33.2.6 ADC Conversion Procedure (Basic Mode)

This is an example procedure for using the ADC to perform an Analog-to-Digital Conversion:

1. Configure Port:
 - a. Disable pin output driver (refer to the TRISx register)
 - b. Configure pin as analog (refer to the ANSELx register)
2. Configure the ADC module:
 - a. Select ADC conversion clock
 - b. Configure voltage reference
 - c. Select ADC input channel
 - d. Configure precharge (**ADPRE**) and acquisition (**ADACQ**) time period
 - e. Turn on ADC module
3. Configure ADC interrupt (optional):
 - a. Clear ADC interrupt flag
 - b. Enable ADC interrupt
 - c. Enable global interrupt (GIE bit)⁽¹⁾
4. If **ADACQ** \neq 0, software must wait the required acquisition time⁽²⁾.
5. Start conversion by setting the **GO** bit.
6. Wait for ADC conversion to complete by one of the following:
 - Polling the **GO** bit
 - Waiting for the ADC interrupt (if interrupt is enabled)
7. Read ADC Result.
8. Clear the ADC interrupt flag (if interrupt is enabled).

Notes:

1. With global interrupts disabled (GIE = 0), the device will wake from Sleep, but will not enter an Interrupt Service Routine.
2. Refer to the [ADC Acquisition Requirements](#) section for more details.

Example 33-4. ADC Conversion (Differential Inputs)

```

/*This code block configures the ADC
for polling, VDD and VSS references,
ADCRC oscillator.
Conversion start & polling for completion
are included.
*/
void main()
{
    initializeSystem();    //System Initialize

    //Setup ADC
    ADCON0bits.FM = 10;    //Right justify, sign/magnitude
    ADCON0bits.CS = 1;    //ADCRC Clock
    ADCON0bits.IC = 1;    //Differential mode
    ADPCH = 0x00;        //RA0 is positive input
    ADNCH = 0x01;        //RA1 is negative input
    TRISA0bits.TRISA0 = 1; //Set RA0 to input
    TRISA1bits.TRISA1 = 1; //Set RA1 to input
    ANSELAbits.ANSELA0 = 1; //Set RA0 to analog
    ANSELAbits.ANSELA1 = 1; //Set RA1 to analog
    ADACQ = 32;          //Set acquisition time
    ADCON0bits.ON = 1;   //Turn ADC On

    while (1)
    {
        ADCON0bits.GO = 1; //Start conversion
        while (ADCON0bits.GO); //Wait for conversion done
        resultHigh = ADRESH; //Read result
        resultLow = ADRESL; //Read result
    }
}

```

33.3 ADC Acquisition Requirements

For the ADC to meet its specified accuracy, the charge holding capacitor (C_{HOLD}) must be allowed to fully charge to the input channel voltage level. The analog input model is shown in [Figure 33-9](#). The source impedance (R_S) and the internal sampling switch (R_{SS}) impedance directly affect the time required to charge the capacitor C_{HOLD} . The sampling switch (R_{SS}) impedance varies over the device voltage (V_{DD}). The maximum recommended impedance for analog sources is 10 k Ω . As the source impedance is decreased, the acquisition time may be decreased. After the analog input channel is selected (or changed), an ADC acquisition time must be completed before the conversion can be started. To calculate the minimum acquisition time, [Equation 33-5](#) may be used. This equation assumes an error of 1/2 LSB. The 1/2 LSB error is the maximum error allowed for the ADC to meet its specified resolution.

Equation 33-5. Acquisition Time Example

Assumptions: Temperature = 50°C; External impedance = 10 k Ω ; V_{DD} = 5.0V

T_{ACQ} = Amplifier Settling Time + Hold Capacitor Charging Time + Temperature Coefficient

$$T_{ACQ} = T_{AMP} + T_C + T_{COFF}$$

$$T_{ACQ} = 2 \mu s + T_C + [(Temperature - 25^\circ C) (0.05 \mu s / ^\circ C)]$$

The value for T_C can be approximated with the following equations:

$$V_{APPLIED} \left(1 - \frac{1}{(2^n + 1) - 1} \right) = V_{CHOLD}; [1] V_{CHOLD} \text{ charged to within } \frac{1}{2} \text{ LSB}$$

$$V_{APPLIED} \left(1 - e^{-\frac{T_C}{RC}} \right) = V_{CHOLD}; [2] V_{CHOLD} \text{ charge response to } V_{APPLIED}$$

$$V_{APPLIED} \left(1 - e^{-\frac{T_C}{RC}} \right) = V_{APPLIED} \left(1 - \frac{1}{(2^n + 1) - 1} \right); \text{ Combining [1] and [2]}$$

Note: Where n = ADC resolution in bits

Solving for T_C:

$$T_C = -C_{HOLD}(R_{IC} + R_{SS} + R_S) \ln (1/8191)$$

$$T_C = -28 \text{ pF}(1 \text{ k}\Omega + 7 \text{ k}\Omega + 10 \text{ k}\Omega) \ln (0.0001221)$$

$$T_C = 4.54 \text{ }\mu\text{s}$$

Therefore:

$$T_{ACQ} = 2 \text{ }\mu\text{s} + 4.54 \text{ }\mu\text{s} + [(50^\circ\text{C} - 25^\circ\text{C}) (0.05 \text{ }\mu\text{s}/^\circ\text{C})]$$

$$T_{ACQ} = 7.79 \text{ }\mu\text{s}$$



Important:

- The reference voltage (V_{REF}) has no effect on the equation, since it cancels itself out
- The charge holding capacitor (C_{HOLD}) is not discharged after each conversion
- The maximum recommended impedance for analog sources is 10 kΩ. This is required to meet the pin leakage specification.

Figure 33-9. Analog Input Model

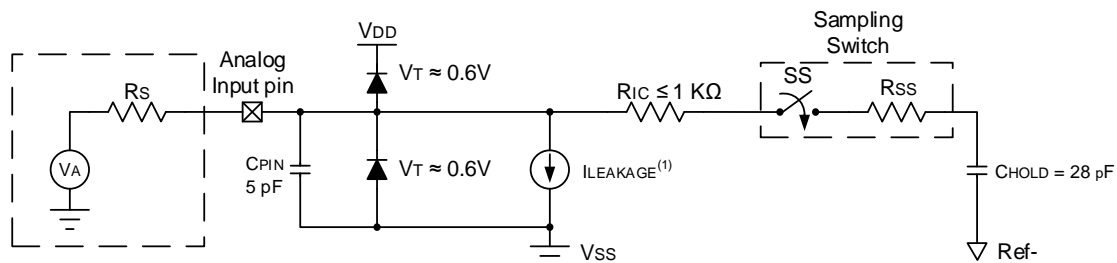

- Legend:**
- CPIN = Input Capacitance
 - ILEAKAGE = Leakage Current at the pin due to various junctions
 - RIC = Interconnect Resistance
 - RS = Source Impedance
 - VA = Analog Voltage
 - VT = Diode Forward Voltage
 - SS = Sampling Switch
 - RSS = Resistance of the Sampling Switch
 - CHOLD = Sample/Hold Capacitance

Note:

1. Refer to the **“Electrical Specifications”** chapter of the device data sheet for more details.

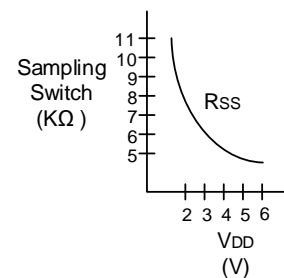
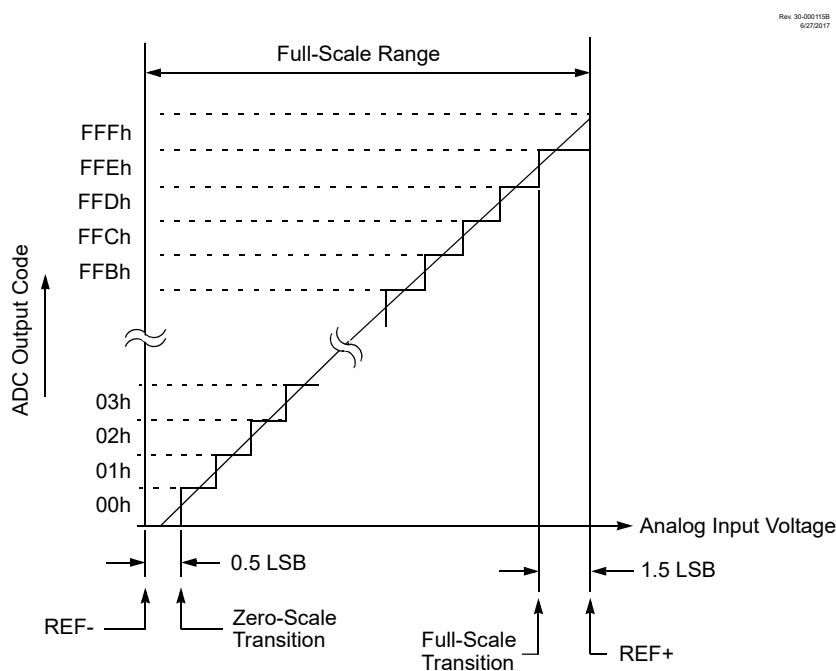

Figure 33-10. ADC Transfer Function



33.4 Computation Operation

The ADC module hardware is equipped with post-conversion computation features. These features provide post-processing functions such as digital filtering/averaging and threshold comparison. Based on computation results, the module can be configured to take additional samples or stop conversions and an interrupt may be asserted.

Figure 33-11. Computational Features Simplified Block Diagram

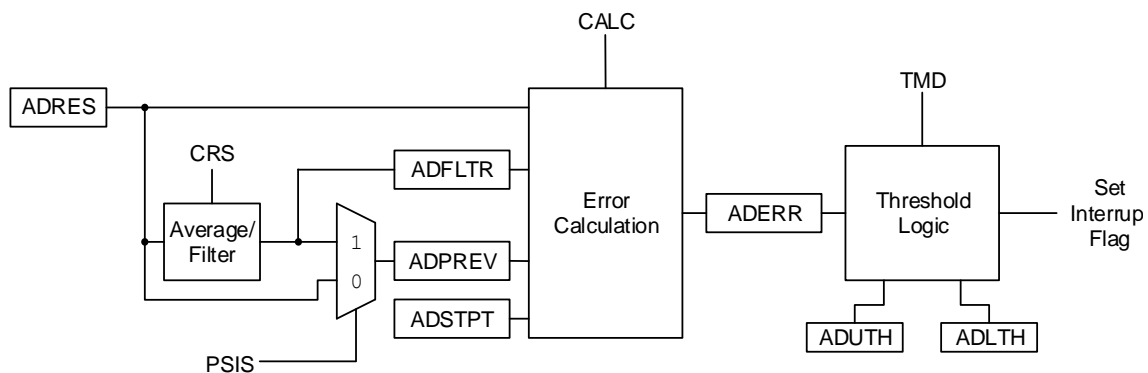

The operation of the ADC computational features is controlled by the MD bits.

The module can be operated in one of five modes:

- **Basic:** This is a Legacy mode. In this mode, ADC conversion occurs on single (DSEN = 0) or double (DSEN = 1) samples. ADIF is set after each conversion is complete. ADTIF is set according to the Calculation mode.

- **Accumulate:** With each trigger, the ADC conversion result is added to the accumulator and **ADCNT** increments. ADIF is set after each conversion. ADTIF is set according to the Calculation mode.
- **Average:** With each trigger, the ADC conversion result is added to the accumulator. When the **RPT** number of samples have been accumulated, a threshold test is performed. Upon the next trigger, the accumulator is cleared. For the subsequent tests, additional RPT samples are required to be accumulated.
- **Burst Average:** At the trigger, the accumulator is cleared. The ADC conversion results are then collected repetitively until RPT samples are accumulated and finally the threshold is tested.
- **Low-Pass Filter (LPF):** With each trigger, the ADC conversion result is sent through a filter. When RPT samples have occurred, a threshold test is performed. Every trigger after that, the ADC conversion result is sent through the filter and another threshold test is performed.

The five modes are summarized in the following table.

Table 33-2. Computation Modes

Mode	MD	Register Clear Event	Value after Cycle ⁽¹⁾ Completion		Threshold Operations			Value at ADTIF Interrupt		
		ADACC and CNT	ADACC	ADCNT	Retrigger	Threshold Test	Interrupt	AOV	ADFLTR	ADCNT
Basic	0	ACLR = 1	Unchanged	Unchanged	No	Every Sample	If threshold=true	N/A	N/A	count
Accumulate	1	ACLR = 1	S1 + ADACC or (S2-S1) ⁽²⁾ + ADACC	If (ADCNT = 0xFF): ADCNT, otherwise: ADCNT+1	No	Every Sample	If threshold=true	ADACC Overflow	ADACC/2 ^{CRS}	count
Average	2	ACLR = 1 or ADCNT ≥ ADRPT at GO set or retrigger	S1 + ADACC or (S2-S1) + ADACC	If (ADCNT = 0xFF): ADCNT, otherwise: ADCNT+1	No	If ADCNT ≥ ADRPT	If threshold=true	ADACC Overflow	ADACC/2 ^{CRS}	count
Burst Average	3	ACLR = 1 or at GO set or retrigger	Each repetition: same as Average End with sum of all samples	Each repetition: same as Average End with ADCNT = ADRPT	Repeat while ADCNT < ADRPT	If ADCNT ≥ ADRPT	If threshold=true	ADACC Overflow	ADACC/2 ^{CRS}	ADRPT
Low-pass Filter	4	ACLR = 1	S1 + ADACC- ADACC/ 2 ^{CRS} or (S2-S1) + ADACC-ADACC/2 ^{CRS}	If (ADCNT = 0xFF): ADCNT, otherwise: ADCNT+1	No	If ADCNT ≥ ADRPT	If threshold=true	ADACC Overflow	ADACC/2 ^{CRS} (Filtered Value)	count

Notes:

1. When DSEN = 0, Cycle means one conversion. When DSEN = 1, Cycle means two conversions.
2. S1 and S2 are abbreviations for Sample 1 and Sample 2, respectively. When DSEN = 0, S1 = ADRES; when DSEN = 1, S1 = ADPREV and S2 = ADRES.

33.4.1 Digital Filter / Average

The digital filter/average module consists of an accumulator with data feedback options and control logic to determine when threshold tests need to be applied. The accumulator can be accessed through the [ADACC](#) register.

Upon each trigger event (the GO bit set or external event trigger), the ADC conversion result is added to or subtracted from the accumulator. If the accumulated value exceeds $2^{(\text{accumulator_width})-1} = 2^{18-1} = 262143$, the [AOV](#) overflow bit is set.

The number of samples to be accumulated is determined by the [ADRPT](#) (ADC Repeat Setting) register. Each time a sample is added to the accumulator, the [ADCNT](#) register is incremented. Once the ADRPT samples are accumulated ($\text{ADCNT} = \text{ADRPT}$), the accumulator may be cleared automatically depending on ADC Operation mode. An accumulator clear command can be issued in software by setting the [ACLR](#) bit. Setting the ACLR bit will also clear the AOV (Accumulator Overflow) bit, as well as the ADCNT register. The ACLR bit is cleared by the hardware when accumulator clearing action is complete.



Important: When ADC is operating from ADCRC, up to five ADCRC clock cycles are required to execute the ADACC clearing operation.

The [CRS](#) bits control the data shift on the accumulator result, which effectively divides the value in the accumulator registers. For the Accumulate mode of the digital filter, the shift provides a simple scaling operation. For the Average/Burst Average mode, the calculated average is only accurate when the number of samples agrees with the number of bits shifted. For the Low-Pass Filter mode, the shift is an integral part of the filter and determines the cutoff frequency of the filter. [Table 33-3](#) shows the -3 dB cutoff frequency in ωT (radians) and the highest signal attenuation obtained by this filter at Nyquist frequency ($\omega T = \pi$).

Table 33-3. Low-Pass Filter -3 dB Cutoff Frequency

CRS	ωT (radians) @ -3 dB Frequency	dB @ $F_{\text{Nyquist}} = 1/(2T)$
1	0.72	-9.5
2	0.284	-16.9
3	0.134	-23.5
4	0.065	-29.8
5	0.032	-36.0
6	0.016	-42.0

33.4.2 Basic Mode

Basic mode ($\text{MD} = \text{b}000$) disables all additional computation features. In this mode, no accumulation occurs but threshold error comparison is performed. Double sampling, Continuous mode, and all CVD features are still available, but no digital filter/average calculations are performed.

33.4.3 Accumulate Mode

In Accumulate mode ($\text{MD} = \text{b}001$), after every conversion, the ADC result is added to the [ADACC](#) register. The ADACC register is right-shifted by the value of the [CRS](#) bits. This right-shifted value is copied into the [ADFLTR](#) register. The Formatting mode does not affect the right-justification of the ADACC or ADFLTR values. Upon each sample, [ADCNT](#) is incremented, counting the number of samples accumulated. After each sample and accumulation, the ADFLTR value has a threshold comparison performed on it (see the [Threshold Comparison](#) section) and the ADTIF interrupt may trigger.

33.4.4 Average Mode

In Average mode ($MD = \text{'b}010$), the **ADACC** registers accumulate with each ADC sample, much as in Accumulate mode, and the **ADCNT** register increments with each sample. The **ADFLTR** register is also updated with the right-shifted value of the **ADACC** register. The value of the **CRS** bits governs the number of right shifts. However, in Average mode, the threshold comparison is performed upon **ADCNT** being greater than or equal to a user-defined **ADRPT** value. In this mode, when $ADRPT = 2^{CRS}$, the final accumulated value will be divided by the number of samples, allowing for a threshold comparison operation on the average of all gathered samples.

33.4.5 Burst Average Mode

The Burst Average mode ($MD = \text{'b}011$) acts the same as the Average mode in most respects. The one way it differs is that it continuously retriggers ADC sampling until the **CNT** value is equal to **RPT**, even if Continuous Sampling mode (see [Continuous Sampling Mode](#)) is not enabled. This provides a threshold comparison on the average of a short burst of ADC samples.

33.4.6 Low-Pass Filter Mode

The Low-Pass Filter mode ($MD = \text{'b}100$) acts similarly to the Average mode in how it handles samples; it accumulates samples until the **CNT** value is greater than or equal to **RPT**, then triggers a threshold comparison. But, instead of a simple average, it performs a low-pass filter operation on all of the samples, reducing the effect of high-frequency noise on the total, then performs a threshold comparison on the results. In this mode, the **CRS** bits determine the cutoff frequency of the low-pass filter (as demonstrated by the [Digital Filter/Average](#) section). Refer to the [Computation Operation](#) section for a more detailed description of the mathematical operation.

For more information about Low-Pass Filter mode, refer to the following Microchip application note, available at the corporate website (www.microchip.com):

- AN2749, "Using PIC18 12-bit ADC² in Low-Pass Filter Mode"

33.4.7 Threshold Comparison

At the end of each computation:

- The conversion results are captured at the end-of-conversion.
- The error (**ADERR**) is calculated based on a difference calculation which is selected by the **CALC** bits. The value can be one of the following calculations:
 - The first derivative of single measurements
 - The CVD result when double sampling is enabled
 - The current result vs. setpoint value in the **ADSTPT** register
 - The current result vs. the filtered/average result
 - The first derivative of the filtered/average value
 - Filtered/average value vs. setpoint value in the **ADSTPT** register
- The result of the calculation (**ADERR**) is compared to the upper and lower thresholds, **ADUTH** and **ADLTH** registers, to set the **UTHR** and **LTHR** Status bits. The threshold logic is selected by the **TMD** bits. The threshold trigger option can be one of the following:
 - Never interrupt
 - Error is less than lower threshold
 - Error is greater than or equal to lower threshold
 - Error is between thresholds (inclusive)
 - Error is outside of thresholds
 - Error is less than or equal to upper threshold

- Error is greater than upper threshold
- Always interrupt regardless of threshold test results
- If the Threshold condition is met, the channel threshold interrupt flag ADTIF is set.



Important:

- The threshold tests are signed operations.
- If the [AOV](#) bit is set, a threshold interrupt is signaled. It is good practice for threshold interrupt handlers to verify the validity of the threshold by checking the AOV bit.

33.4.8 Repetition and Sampling Options

33.4.8.1 Continuous Sampling Mode

Setting the [CONT](#) bit automatically retriggers a new conversion cycle after updating the [ADACC](#) register. That means the [GO](#) bit remains set to generate automatic retriggering. If [SOI](#) = 1, a Threshold Interrupt condition will clear the [GO](#) bit and the conversion will stop.

33.4.8.2 Double Sample Conversion

Double sampling is enabled by setting the [DSEN](#) bit. When this bit is set, two conversions are required before the module calculates the threshold error. Each conversion must be triggered separately when [CONT](#) = 0, but will repeat automatically from a single trigger when [CONT](#) = 1. The first conversion will set the [MATH](#) bit and update the [ADACC](#) register, but will not calculate [ADERR](#) or trigger [ADTIF](#). When the second conversion completes, the first value is transferred to [ADPREV](#) (depending on the setting of [PSIS](#)) and the value of the second conversion is placed into [ADRES](#). Only upon the completion of the second conversion is [ADERR](#) calculated and [ADTIF](#) triggered (depending on the value of [CALC](#)).

33.4.9 Capacitive Voltage Divider (CVD) Features

The ADC module contains several features that allow the user to perform a relative capacitance measurement on any ADC channel using the internal ADC Sample-and-Hold capacitance as a reference. This relative capacitance measurement can be used to implement capacitive touch or proximity sensing applications. The following figure shows the basic block diagram of the CVD portion of the ADC module.

Figure 33-12. Hardware Capacitive Voltage Divider Block Diagram

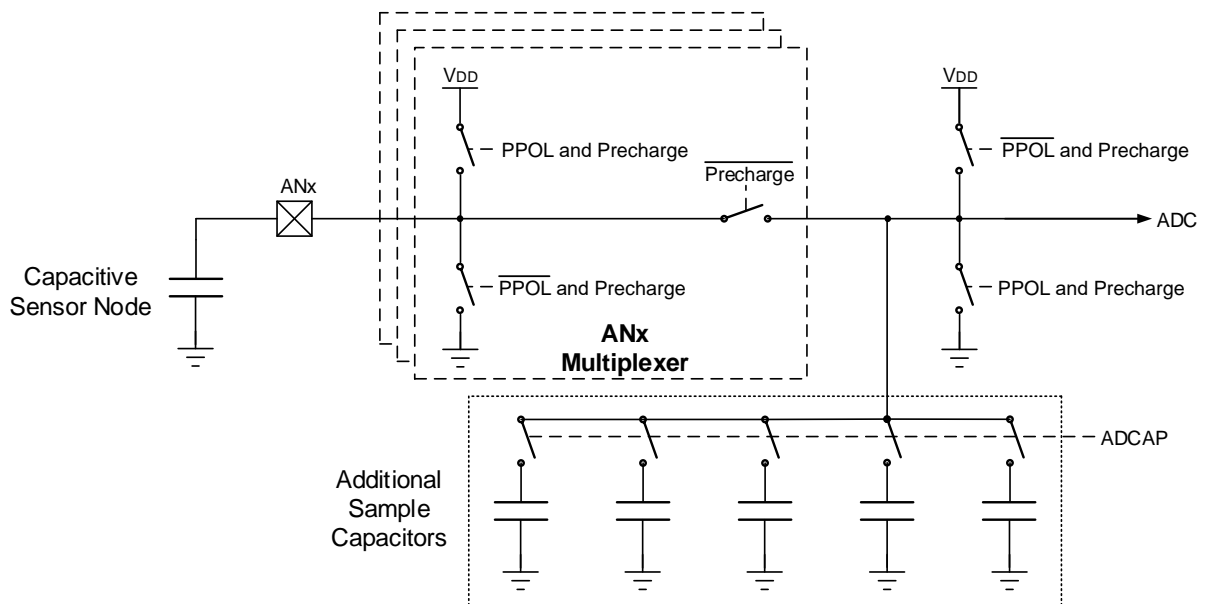

This is an example to configure ADC for CVD operation:

1. Configure Port:
 - a. Disable pin output driver (refer to the TRISx register)
 - b. Configure pin as analog (refer to the ANSELx register)
2. Configure the ADC module:
 - a. Select ADC conversion clock
 - b. Configure voltage reference
 - c. Select ADC input channel
 - d. Configure precharge (ADPRE) and acquisition (ADACQ) time period
 - e. Select precharge polarity (PPOL)
 - f. Enable Double Sampling (DSEN)
 - g. Turn on ADC module
3. Configure ADC interrupt (optional):
 - a. Clear ADC interrupt flag
 - b. Enable ADC interrupt
 - c. Enable global interrupt (GIE bit)⁽¹⁾
4. Start double sample conversion by setting the GO bit.
5. Wait for ADC conversion to complete by one of the following:
 - Polling the GO bit
 - Waiting for the ADC interrupt (if interrupt is enabled)
6. Second ADC conversion depends on the state of CONT:
 - a. If CONT = 1, both conversion will repeat automatically form a single trigger.
 - b. If CONT = 0, each conversion must be triggered separately.
7. ADERR register contains the CVD result

- Clear the ADC interrupt flag (if interrupt is enabled).

Note:

- With global interrupts disabled ($GIE = 0$), the device will wake from Sleep, but will not enter an Interrupt Service Routine.

33.4.9.1 CVD Operation

A CVD operation begins with the ADC's internal Sample-and-Hold capacitor (C_{HOLD}) being disconnected from the path, which connects it to the external capacitive sensor node. While disconnected, C_{HOLD} is precharged to V_{DD} or discharged to V_{SS} . If the **PCSC** bit is clear, the sensor node is either discharged or charged to V_{SS} or V_{DD} , respectively to the opposite level of C_{HOLD} . If **PCSC** is set, the external capacitive sensor node receives no precharge. When the precharge phase is complete, the V_{DD}/V_{SS} bias paths for the two nodes are disconnected and the paths between C_{HOLD} and the external sensor node is reconnected, at which time the acquisition phase of the CVD operation begins. During acquisition, a capacitive voltage divider is formed between the precharged C_{HOLD} and sensor nodes, which results in a final voltage level setting on C_{HOLD} , which is determined by the capacitances and precharge levels of the two nodes. After acquisition, the ADC converts the voltage level on C_{HOLD} . This process is then repeated with the selected precharge levels inverted for both the C_{HOLD} and the sensor nodes. The waveform for two CVD measurements, which is known as differential CVD measurement, is shown in the following figure.

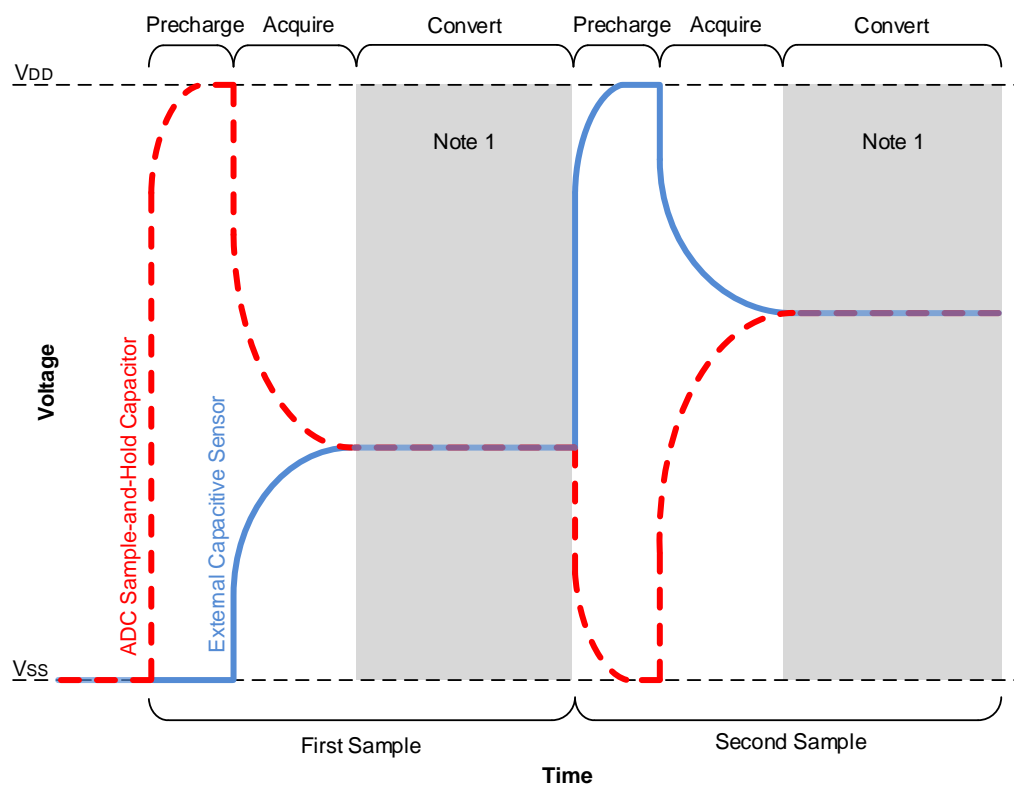
Figure 33-13. Differential CVD Measurement Waveform

Note 1: External Capacitive Sensor voltage during the conversion phase may vary as per the configuration of the corresponding pin.

33.4.9.2 Precharge Control

The precharge stage is the period of time that brings the external channel and internal Sample-and-Hold capacitor to known voltage levels. Precharge is enabled by writing a nonzero value to the **ADPRE** register. This stage is initiated when an ADC conversion begins, either from setting the **GO**

bit, a Special Event Trigger, or a conversion restart from the computation functionality. If the ADPRE register is cleared when an ADC conversion begins, this stage is skipped.

The Precharge Sample Capacitor Only (PCSC) bit can be used to disable the precharge stage to the external channel.

During the precharge time, C_{HOLD} is disconnected from the outer portion of the sample path that leads to the external capacitive sensor and is connected to either V_{DD} or V_{SS} , depending on the value of the PPOL bit. At the same time, when PCSC is clear ($\text{PCSC} = 0$), the port pin logic of the selected analog channel is overridden to drive a digital high or low out, to precharge the outer portion of the ADC's sample path, which includes the external sensor. The output polarity of this override is determined by the PPOL bit such that the external sensor cap is charged opposite that of the internal C_{HOLD} cap. If PCSC is set ($\text{PCSC} = 1$), the outer portion of the ADC's sample path is disconnected, preventing the precharge from occurring on the external channel. The amount of time for precharge is controlled by the ADPRE register.



Important: The external charging overrides the TRIS/LAT/Guard outputs setting of the respective I/O pin. If there is a device attached to this pin, the PCSC bit will be set or precharge will not be used.

33.4.9.3 Acquisition Control for CVD ($\text{ADPRE} > 0$)

The acquisition stage allows time for the voltage on the internal Sample-and-Hold capacitor to charge or discharge from the selected analog channel. This acquisition time is controlled by the ADACQ register. The acquisition stage begins when precharge stage ends.

At the start of the acquisition stage, the port pin logic of the selected analog channel is overridden to turn off the digital high/low output drivers so they do not affect the final result of the charge averaging. Also, the selected ADC channel is connected to C_{HOLD} . This allows charge averaging to proceed between the precharged channel and the C_{HOLD} capacitor.



Important: When $\text{ADPRE} > 0$, setting ADACQ to '0' will set a maximum acquisition time. When precharge is disabled, setting ADACQ to '0' will disable hardware acquisition time control.

33.4.9.4 Guard Ring Outputs

Figure 33-14 shows a typical guard ring circuit. C_{GUARD} represents the capacitance of the guard ring trace placed on the PCB. The user selects values for R_A and R_B that will create a voltage profile on C_{GUARD} , which will match the selected acquisition channel.

The purpose of the guard ring is to generate a signal in phase with the CVD sensing signal to minimize the effects of the parasitic capacitance on sensing electrodes. It also can be used as a mutual drive for mutual capacitive sensing. For more information about active guard and mutual drive, refer to the following Microchip application note, available at the corporate website (www.microchip.com):

- AN1478, "mTouch™ Sensing Solution Acquisition Methods Capacitive Voltage Divider"

The ADC has two guard ring drive outputs, ADGRDA and ADGRDB. These outputs are routed through PPS controls to I/O pins. Refer to the "PPS - Peripheral Pin Select Module" chapter for more details. The polarity of these outputs is controlled by the GPOL and IPEN bits.

At the start of the first precharge stage, both outputs are set to match the GPOL bit. Once the acquisition stage begins, ADGRDA changes polarity, while ADGRDB remains unchanged. When performing a double sample conversion, setting the IPEN bit causes both guard ring outputs to transition to the opposite polarity of GPOL at the start of the second precharge stage, and ADGRDA

toggles again for the second acquisition. For more information on the timing of the guard ring output, refer to [Figure 33-15](#).

Figure 33-14. Guard Ring Circuit

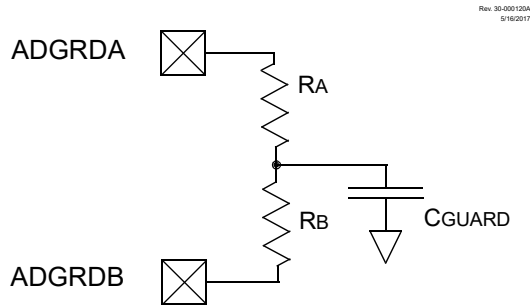
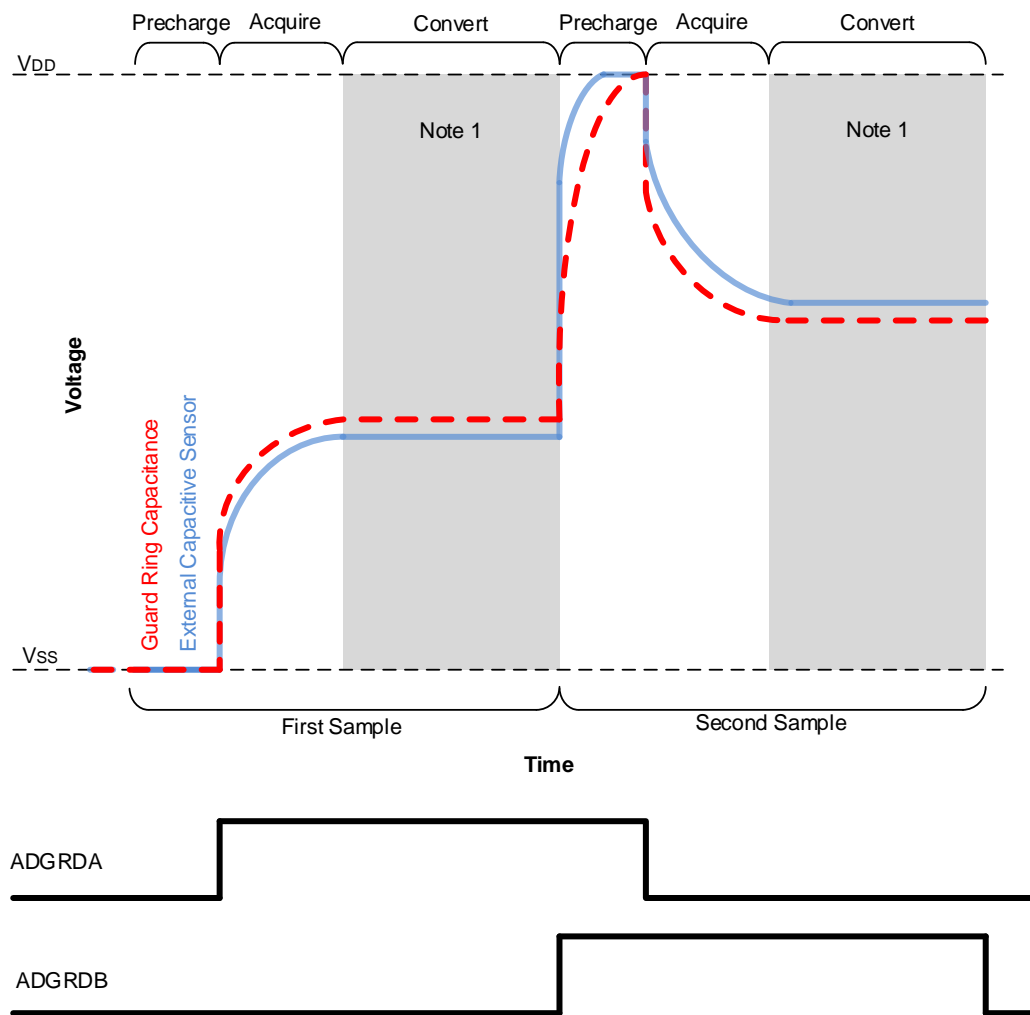

Figure 33-15. Differential CVD with Guard Ring Output Waveform



Note 1: External Capacitive Sensor voltage during the conversion phase may vary as per the configuration of the corresponding pin.

33.4.9.5 Additional Sample-and-Hold Capacitance

Additional capacitance can be added in parallel with the internal Sample-and-Hold capacitor (C_{HOLD}) by using the [ADCAP](#) register. This register selects a digitally programmable capacitance that is added to the ADC conversion bus, increasing the effective internal capacitance of the Sample-and-Hold capacitor in the ADC module. This is used to improve the match between internal and external capacitance for a better sensing performance. The additional capacitance does not affect analog performance of the ADC because it is not connected during conversion.

33.5 Register Definitions: ADC Control

Long bit name prefixes for the ADC peripherals are shown in the following table. Refer to the “**Long Bit Names**” section in the “**Register and Bit Naming Conventions**” chapter for more information.

Table 33-4. ADC Long Bit Name Prefixes

Peripheral	Bit Name Prefix
ADC	AD

33.5.1 ADCON0

Name: ADCON0

Offset: 0x1D26

ADC Control Register 0

Bit	7	6	5	4	3	2	1	0
	ON	CONT		CS	FM[1:0]		IC	GO
Access	R/W	R/W		R/W	R/W	R/W	R/W	R/W/HC/HS
Reset	0	0		0	0	0	1	0

Bit 7 – ON ADC Enable

Value	Description
1	ADC is enabled
0	ADC is disabled

Bit 6 – CONT ADC Continuous Operation Enable

Value	Description
1	GO is retriggered upon completion of each conversion trigger until ADTIF is set (if SOI is set) or until GO is cleared (regardless of the value of SOI)
0	ADC is cleared upon completion of each conversion trigger

Bit 4 – CS ADC Clock Selection

Value	Description
1	Clock supplied from ADCRC dedicated oscillator
0	Clock supplied by F_{OSC} , divided according to the ADCLK register

Bits 3:2 – FM[1:0] ADC Results Format/Alignment Selection

Value	Condition	Description
x1	IC = 0	ADRES and ADPREV data are right justified
x0	IC = 0	ADRES and ADPREV data are left justified, zero-filled
11	IC = 1	ADRES and ADPREV data are right justified, sign bit
10	IC = 1	ADRES and ADPREV data are left justified, sign bit, zero-filled
01	IC = 1	ADRES and ADPREV data are right justified, two's complement
00	IC = 1	ADRES and ADPREV data are left justified, two's complement, zero-filled

Bit 1 – IC ADC Input Configuration

Value	Description
1	ADC is operating in Differential mode
0	ADC is operating in Single-Ended mode

Bit 0 – GO ADC Conversion Status^(1,2)

Value	Description
1	ADC conversion cycle in progress. Setting this bit starts an ADC conversion cycle. The bit is cleared by hardware as determined by the CONT bit.
0	ADC conversion completed/not in progress

Notes:

1. This bit requires the ON bit to be set.
2. If cleared by software while a conversion is in progress, the results of the conversion up to this point will be transferred to ADRES and the state machine will be reset, but the ADIF interrupt flag bit will not be set; filter and threshold operations will not be performed.

33.5.2 ADCON1

Name: ADCON1

Offset: 0x1D27

ADC Control Register 1

Bit	7	6	5	4	3	2	1	0
	PPOL	IPEN	GPOL				PCSC	DSEN
Access	R/W	R/W	R/W				R/W	R/W
Reset	0	0	0				0	0

Bit 7 – PPOL Precharge Polarity

Action During 1st Precharge Stage

Value	Condition	Description
x	ADPRE = 0	Bit has no effect
1	ADPRE > 0	External analog I/O pin is connected to V _{DD} Internal AD sampling capacitor (C _{HOLD}) is connected to V _{SS}
0	ADPRE > 0	External analog I/O pin is connected to V _{SS} Internal AD sampling capacitor (C _{HOLD}) is connected to V _{DD}

Bit 6 – IPEN A/D Inverted Precharge Enable

Value	Condition	Description
x	DSEN = 0	Bit has no effect
1	DSEN = 1	The precharge and guard signals in the second conversion cycle are the opposite polarity of the first cycle
0	DSEN = 1	Both Conversion cycles use the precharge and guards specified by PPOL and GPOL

Bit 5 – GPOL Guard Ring Polarity Selection

Value	Description
1	ADC guard Ring outputs start as digital high during Precharge stage
0	ADC guard Ring outputs start as digital low during Precharge stage

Bit 1 – PCSC Precharge Sample Capacitor Only

Value	Description
1	Precharge only applies to the internal sampling capacitor
0	Precharge applies to both the internal sampling capacitor and the external I/O pin

Bit 0 – DSEN Double-Sample Enable

Value	Description
1	Two conversions are processed as a pair. The selected computation is performed after every second conversion.
0	Selected computation is performed after every conversion

33.5.3 ADCON2

Name: ADCON2

Offset: 0x1D28

ADC Control Register 2

Bit	7	6	5	4	3	2	1	0
	PSIS	CRS[2:0]			ACLR	MD[2:0]		
Access	R/W	R/W	R/W	R/W	R/W/HC	R/W	R/W	R/W
Reset	0	0	0	0	0	0	0	0

Bit 7 – PSIS ADC Previous Sample Input Select

Value	Description
1	ADFLTR is transferred to ADPREV at the start of conversion
0	ADRES is transferred to ADPREV at the start of conversion

Bits 6:4 – CRS[2:0] ADC Accumulated Calculation Right Shift Select

Value	Condition	Description
1 to 6	MD = 'b100	Low-pass filter time constant is 2^{CRS} , filter gain is 1:1 ⁽²⁾
1 to 6	MD = 'b011 to 'b001	The accumulated value is right-shifted by CRS (divided by 2^{CRS}) ^(1,2)
x	MD = 'b000 or 'b111	These bits are ignored

Bit 3 – ACLR A/D Accumulator Clear Command⁽³⁾

Value	Description
1	Registers ADACC, ADCNT and the AOV bit are cleared
0	Clearing action is complete (or not started)

Bits 2:0 – MD[2:0] ADC Operating Mode Selection⁽⁴⁾

Value	Description
111-101	Reserved
100	Low-Pass Filter mode
011	Burst Average mode
010	Average mode
001	Accumulate mode
000	Basic (Legacy) mode

Notes:

- To correctly calculate an average, the number of samples (set in ADRPT) must be 2^{CRS} .
- CRS = 'b111 and 'b000 are reserved.
- This bit is cleared by hardware when the accumulator operation is complete; depending on oscillator selections, the delay may be many instructions.
- See the **“Computation Operation”** section for full mode descriptions.

33.5.4 ADCON3

Name: ADCON3

Offset: 0x1D29

ADC Control Register 3

Bit	7	6	5	4	3	2	1	0
		CALC[2:0]			SOI	TMD[2:0]		
Access		R/W	R/W	R/W	R/W/HC	R/W	R/W	R/W
Reset		0	0	0	0	0	0	0

Bits 6:4 – CALC[2:0] ADC Error Calculation Mode Select

Table 33-5. ADC Error Calculation Mode

CALC	ADERR		Application
	DSEN = 0 Single-Sample Mode	DSEN = 1 CVD Double-Sample Mode ⁽¹⁾	
111	Reserved	Reserved	Reserved
110	Reserved	Reserved	Reserved
101	ADFLTR-ADSTPT	ADFLTR-ADSTPT	Average/filtered value vs. setpoint
100	ADPREV-ADFLTR	ADPREV-ADFLTR	First derivative of filtered value ⁽³⁾ (negative)
011	Reserved	Reserved	Reserved
010	ADRES-ADFLTR	(ADRES-ADPREV)-ADFLTR	Actual result vs. averaged/filtered value
001	ADRES-ADSTPT	(ADRES-ADPREV)-ADSTPT	Actual result vs. setpoint
000	ADRES-ADPREV	ADRES-ADPREV	First derivative of single measurement ⁽²⁾
			Actual CVD result ⁽²⁾

Notes:

- When DSEN = 1 and PSIS = 0, ADERR is computed only after every second sample.
- When PSIS = 0.
- When PSIS = 1.

Bit 3 – SOI ADC Stop-on-Interrupt

Value	Condition	Description
x	CONT = 0	This bit is not used
1	CONT = 1	GO is cleared when the Threshold conditions are met, otherwise the conversion is retrigged
0	CONT = 1	GO is not cleared by hardware, must be cleared by software to stop retriggers

Bits 2:0 – TMD[2:0] Threshold Interrupt Mode Select

Value	Description
111	Interrupt regardless of threshold test results
110	Interrupt if ADERR > ADUTH
101	Interrupt if ADERR ≤ ADUTH
100	Interrupt if ADERR < ADLTH or ADERR > ADUTH
011	Interrupt if ADERR > ADLTH and ADERR < ADUTH
010	Interrupt if ADERR ≥ ADLTH
001	Interrupt if ADERR < ADLTH
000	Never interrupt

33.5.5 ADSTAT

Name: ADSTAT
Offset: 0x1D2A

ADC Status Register

Bit	7	6	5	4	3	2	1	0
	AOV	UTHR	LTHR	MATH		STAT[2:0]		
Access	R/C/HS/HC	R	R	R/W/HS		R	R	R
Reset	0	0	0	0		0	0	0

Bit 7 – AOV ADC Accumulator Overflow

Value	Description
1	ADACC or ADFLTR or ADERR registers have overflowed
0	ADACC, ADFLTR and ADERR registers have not overflowed

Bit 6 – UTHR ADC Module Greater-than Upper Threshold Flag

Value	Description
1	ADERR > ADUTH
0	ADERR ≤ ADUTH

Bit 5 – LTHR ADC Module Less-than Lower Threshold Flag

Value	Description
1	ADERR < ADLTH
0	ADERR ≥ ADLTH

Bit 4 – MATH ADC Module Computation Status

ADC Module Computation Status⁽¹⁾

Value	Description
1	Registers ADACC, ADFLTR, ADUTH, ADLTH and the AOV bit are updating or have already updated
0	Associated registers/bits have not changed since this bit was last cleared

Bits 2:0 – STAT[2:0] ADC Module Cycle Multi-Stage Status

Value	Description
111	ADC module is in 2 nd conversion stage
110	ADC module is in 2 nd acquisition stage
101	ADC module is in 2 nd precharge stage
100	ADC computation is suspended between 1st and 2nd sample; the computation results are incomplete and awaiting data from the 2nd sample ^(2,3)
011	ADC module is in 1 st conversion stage
010	ADC module is in 1 st acquisition stage
001	ADC module is in 1 st precharge stage
000	ADC module is not converting

Notes:

1. MATH bit cannot be cleared by software while STAT = 'b100.
2. If ADC clock source is ADCRC and F_{OSC} < ADCRC, the indicated status may not be valid.
3. STAT = 'b100 appears between the two triggers when DSEN = 1 and CONT = 0.

33.5.6 ADCLK

Name: ADCLK
Offset: 0x1D2D

ADC Clock divider Register

Bit	7	6	5	4	3	2	1	0
			CS[5:0]					
Access			R/W	R/W	R/W	R/W	R/W	R/W
Reset			0	0	0	0	0	0

Bits 5:0 – CS[5:0] ADC Clock divider Select

Value	Description
n	ADC Clock frequency = $F_{OSC}/(2^{*(n+1)})$

Note: ADC Clock divider is only available if F_{OSC} is selected as the ADC clock source (CS = 0).

33.5.7 ADREF

Name: ADREF
Offset: 0x1D2B

ADC Reference Selection Register

Bit	7	6	5	4	3	2	1	0
							PREF[1:0]	
Access							R/W	R/W
Reset							0	0

Bits 1:0 – PREF[1:0] ADC Positive Voltage Reference Selection

Value	Description
11	V_{REF+} is connected to internal Fixed Voltage Reference (FVR) module
10	V_{REF+} is connected to external V_{REF+}
01	Reserved
00	V_{REF+} is connected to V_{DD}

33.5.8 ADPCH

Name: ADPCH

Offset: 0x1D1F

ADC Positive Channel Selection Register

Bit	7	6	5	4	3	2	1	0
			PCH[5:0]					
Access			R/W	R/W	R/W	R/W	R/W	R/W
Reset			0	0	0	0	0	0

Bits 5:0 – PCH[5:0] ADC Positive Input Channel Selection

Table 33-6. ADC Positive Input Channel Selections

PCH	ADC Positive Channel Input
111111	Fixed Voltage Reference (FVR) Buffer 2 ⁽¹⁾
111110	Fixed Voltage Reference (FVR) Buffer 1 ⁽¹⁾
111101	DAC2OUT
111100	DAC1OUT
111011	Temperature Indicator ⁽²⁾
111010	V _{SS} (Analog Ground)
111001–011000	Reserved. No channel connected.
010111	RC7 ⁽³⁾
010110	RC6 ⁽³⁾
010101	RC5 ⁽⁴⁾
010100	RC4 ⁽⁴⁾
010011	RC3 ⁽⁴⁾
010010	RC2 ⁽⁴⁾
010001	RC1 ⁽⁴⁾
010000	RC0 ⁽⁴⁾
001111	RB7 ⁽³⁾
001110	RB6 ⁽³⁾
001101	RB5 ⁽³⁾
001100	RB4 ⁽³⁾
001011–000110	Reserved. No channel connected.
000101	RA5
000100	RA4
000011	ADCG1
000010	RA2
000001	RA1
000000	RA0

Notes:

1. Refer to the “Fixed Voltage Reference Module” chapter for more details.
2. Refer to the “Temperature Indicator Module” chapter for more details.
3. 20-pin devices only.
4. 14/20-pin devices only.

33.5.9 ADNCH

Name: ADNCH
Offset: 0x1D20

ADC Negative Channel Selection Register

Bit	7	6	5	4	3	2	1	0
			NCH[5:0]					
Access			R/W	R/W	R/W	R/W	R/W	R/W
Reset			0	0	0	0	0	0

Bits 5:0 – NCH[5:0] ADC Negative Input Channel Selection

Table 33-7. ADC Negative Input Channel Selections

NCH	ADC Negative Channel Input
111111	Fixed Voltage Reference (FVR) Buffer 2 ⁽¹⁾
111110	Fixed Voltage Reference (FVR) Buffer 1 ⁽¹⁾
111101	DAC2_OUT ⁽²⁾
111100	DAC1_OUT ⁽²⁾
111011	Temperature Indicator ⁽³⁾
111010	V _{SS} (Analog Ground)
111001-011000	Reserved. No channel connected.
010111	RC7 ⁽⁴⁾
010110	RC6 ⁽⁴⁾
010101	RC5 ⁽⁵⁾
010100	RC4 ⁽⁵⁾
010011	RC3 ⁽⁵⁾
010010	RC2 ⁽⁵⁾
010001	RC1 ⁽⁵⁾
010000	RC0 ⁽⁵⁾
001111	RB7 ⁽⁴⁾
001110	RB6 ⁽⁴⁾
001101	RB5 ⁽⁴⁾
001100	RB4 ⁽⁴⁾
001011-000110	Reserved. No channel connected.
000101	RA5
000100	RA4
000011	Reserved. No channel connected.
000010	RA2
000001	RA1
000000	RA0

Notes:

1. Refer to the “Fixed Voltage Reference Module” chapter for more details.
2. Refer to the “Digital-to-Analog Converter Module” chapter for more details.
3. Refer to the “Temperature Indicator Module” chapter for more details.
4. 20-pin devices only.
5. 14/20-pin devices only.

33.5.10 ADPRE

Name: ADPRE
Offset: 0x1D24

ADC Precharge Time Control Register

Bit	15	14	13	12	11	10	9	8
				PRE[12:8]				
Access				R/W	R/W	R/W	R/W	R/W
Reset				0	0	0	0	0
Bit	7	6	5	4	3	2	1	0
	PRE[7:0]							
Access	R/W	R/W	R/W	R/W	R/W	R/W	R/W	R/W
Reset	0	0	0	0	0	0	0	0

Bits 12:0 – PRE[12:0] Precharge Time Select

Table 33-8. Precharge Time

ADPRE	Precharge Time	
	CS != ADCRC	CS = ADCRC
1 1111 1111 1111	8191 clocks of F _{OSC}	8191 clocks of ADCRC
1 1111 1111 1110	8190 clocks of F _{OSC}	8190 clocks of ADCRC
1 1111 1111 1101	8189 clocks of F _{OSC}	8189 clocks of ADCRC
...
0 0000 0000 0010	2 clocks of F _{OSC}	2 clocks of ADCRC
0 0000 0000 0001	1 clocks of F _{OSC}	1 clocks of ADCRC
0 0000 0000 0000	Not included in the data conversion cycle	

Notes: The individual bytes in this multibyte register can be accessed with the following register names:

- ADPREH: Accesses the high byte ADPRE[12:8]
- ADPREL: Accesses the low byte ADPRE[7:0]

33.5.11 ADACQ

Name: ADACQ
Offset: 0x1D21

ADC Acquisition Time Control Register

Bit	15	14	13	12	11	10	9	8
				ACQ[12:8]				
Access				R/W	R/W	R/W	R/W	R/W
Reset				0	0	0	0	0
Bit	7	6	5	4	3	2	1	0
	ACQ[7:0]							
Access	R/W	R/W	R/W	R/W	R/W	R/W	R/W	R/W
Reset	0	0	0	0	0	0	0	0

Bits 12:0 – ACQ[12:0] Acquisition (charge share time) Select

Table 33-9. Acquisition Time

ADACQ	Acquisition Time	
	CS != ADCRC	CS = ADCRC
1 1111 1111 1111	8191 clocks of F _{OSC}	8191 clocks of ADCRC
1 1111 1111 1110	8190 clocks of F _{OSC}	8190 clocks of ADCRC
1 1111 1111 1101	8189 clocks of F _{OSC}	8189 clocks of ADCRC
...
0 0000 0000 0010	2 clocks of F _{OSC}	2 clocks of ADCRC
0 0000 0000 0001	1 clocks of F _{OSC}	1 clocks of ADCRC
0 0000 0000 0000	Not included in the data conversion cycle ⁽¹⁾	

Note:

1. If ADPRE is not equal to '0', then ACQ = 0 means Acquisition Time is 8192 clocks of F_{OSC} or ADCRC.

Notes: The individual bytes in this multibyte register can be accessed with the following register names:

- ADACQH: Accesses the high byte ADACQ[12:8]
- ADACQL: Accesses the low byte ADACQ[7:0]

33.5.12 ADCAP

Name: ADCAP
Offset: 0x1D23

ADC Additional Sample Capacitor Selection Register

Bit	7	6	5	4	3	2	1	0
				CAP[4:0]				
Access				R/W	R/W	R/W	R/W	R/W
Reset				0	0	0	0	0

Bits 4:0 – CAP[4:0] ADC Additional Sample Capacitor Selection

Value	Description
1 to 31	Number of pF in the additional capacitance
0	No additional capacitance

33.5.13 ADRPT

Name: ADRPT
Offset: 0x1D1A

ADC Repeat Setting Register

Bit	7	6	5	4	3	2	1	0
	RPT[7:0]							
Access	R/W	R/W	R/W	R/W	R/W	R/W	R/W	R/W
Reset	0	0	0	0	0	0	0	0

Bits 7:0 – RPT[7:0] ADC Repeat Threshold

Determines the number of times that the ADC is triggered for a threshold check. When CNT reaches this value, the error threshold is checked. Used when the computation mode is Low-Pass Filter, Burst Average, or Average. See the **“Computation Operation”** section for more details.

33.5.14 ADCNT

Name: ADCNT
Offset: 0x1D19

ADC Repeat Counter Register

Bit	7	6	5	4	3	2	1	0
	CNT[7:0]							
Access	R/W	R/W	R/W	R/W	R/W	R/W	R/W	R/W
Reset	0	0	0	0	0	0	0	0

Bits 7:0 – CNT[7:0] ADC Repeat Count

Counts the number of times that the ADC is triggered before the threshold is checked. When this value reaches RPT, the threshold is checked. Used when the computation mode is Low-Pass Filter, Burst Average, or Average. See the **“Computation Operation”** section for more details.

33.5.15 ADFLTR**Name:** ADFLTR**Offset:** 0x1D14

ADC Filter Register

Bit	15	14	13	12	11	10	9	8
	FLTR[15:8]							
Access	R	R	R	R	R	R	R	R
Reset	x	x	x	x	x	x	x	x
Bit	7	6	5	4	3	2	1	0
	FLTR[7:0]							
Access	R	R	R	R	R	R	R	R
Reset	x	x	x	x	x	x	x	x

Bits 15:0 – FLTR[15:0] ADC Filter Output - Signed two's complement

In Accumulate, Average, and Burst Average mode, this is equal to ACC right shifted by the CRS bits.
In LPF mode, this is the output of the Low-Pass Filter.

Notes: The individual bytes in this multibyte register can be accessed with the following register names:

- ADFLTRH: Accesses the high byte ADFLTR[15:8]
- ADFLTRL: Accesses the low byte ADFLTR[7:0]

33.5.16 ADRES

Name: ADRES
Offset: 0x1D1D

ADC Result Register

Bit	15	14	13	12	11	10	9	8
	RES[15:8]							
Access	R/W	R/W	R/W	R/W	R/W	R/W	R/W	R/W
Reset	0	0	0	0	0	0	0	0
Bit	7	6	5	4	3	2	1	0
	RES[7:0]							
Access	R/W	R/W	R/W	R/W	R/W	R/W	R/W	R/W
Reset	0	0	0	0	0	0	0	0

Bits 15:0 – RES[15:0] ADC Sample Result

Notes: The individual bytes in this multibyte register can be accessed with the following register names:

- ADRESH: Accesses the high byte ADRES[15:8]
- ADRESL: Accesses the low byte ADRES[7:0]

33.5.17 ADPREV**Name:** ADPREV**Offset:** 0x1D1B

ADC Previous Result Register

Bit	15	14	13	12	11	10	9	8
	PREV[15:8]							
Access	R	R	R	R	R	R	R	R
Reset	0	0	0	0	0	0	0	0
Bit	7	6	5	4	3	2	1	0
	PREV[7:0]							
Access	R	R	R	R	R	R	R	R
Reset	0	0	0	0	0	0	0	0

Bits 15:0 – PREV[15:0] Previous ADC Result

Value	Condition	Description
n	PSIS = 1	n = ADFLTR value at the start of current ADC conversion
n	PSIS = 0	n = ADRES at the start of current ADC conversion ⁽¹⁾

Notes:

1. If PSIS = 0, ADPREV is formatted the same way as ADRES is, depending on the FM bits.
2. The individual bytes in this multibyte register can be accessed with the following register names:
 - ADPREVH: Accesses ADPREV[15:8]
 - ADPREVL: Accesses ADPREV[7:0].

33.5.18 ADACC

Name: ADACC
Offset: 0x1D16

ADC Accumulator Register⁽¹⁾

See the “**Computation Operation**” section for more details.



Important: This register contains signed two's complement accumulator value and the upper unused bits contain copies of the sign bit.

Bit	23	22	21	20	19	18	17	16
							ACC[17:16]	
Access							R/W	R/W
Reset							x	x
Bit	15	14	13	12	11	10	9	8
	ACC[15:8]							
Access	R/W	R/W	R/W	R/W	R/W	R/W	R/W	R/W
Reset	x	x	x	x	x	x	x	x
Bit	7	6	5	4	3	2	1	0
	ACC[7:0]							
Access	R/W	R/W	R/W	R/W	R/W	R/W	R/W	R/W
Reset	x	x	x	x	x	x	x	x

Bits 17:0 – ACC[17:0] ADC Accumulator - Signed two's complement

Notes:

1. This register can only be written when GO = 0.
2. The individual bytes in this multibyte register can be accessed with the following register names:
 - ADACCU: Accesses the upper byte ADACC[17:16]
 - ADACCH: Accesses the high byte ADACC[15:8]
 - ADACCL: Accesses the low byte ADACC[7:0].

33.5.19 ADSTPT**Name:** ADSTPT**Offset:** 0x1D12

ADC Threshold Setpoint Register

Depending on CALC, it may be used to determine ADERR.

Bit	15	14	13	12	11	10	9	8
	STPT[15:8]							
Access	R/W	R/W	R/W	R/W	R/W	R/W	R/W	R/W
Reset	0	0	0	0	0	0	0	0
Bit	7	6	5	4	3	2	1	0
	STPT[7:0]							
Access	R/W	R/W	R/W	R/W	R/W	R/W	R/W	R/W
Reset	0	0	0	0	0	0	0	0

Bits 15:0 – STPT[15:0] ADC Threshold Setpoint - Signed two's complement**Notes:** The individual bytes in this multibyte register can be accessed with the following register names:

- ADSTPTH: Accesses the high byte ADSTPT[15:8]
- ADSTPLH: Accesses the low byte ADSTPT[7:0]

33.5.20 ADERR

Name: ADERR
Offset: 0x1D10

ADC Setpoint Error Register

ADC Setpoint Error calculation is determined by the CALC bits.

Bit	15	14	13	12	11	10	9	8
	ERR[15:8]							
Access	R	R	R	R	R	R	R	R
Reset	x	x	x	x	x	x	x	x
Bit	7	6	5	4	3	2	1	0
	ERR[7:0]							
Access	R	R	R	R	R	R	R	R
Reset	x	x	x	x	x	x	x	x

Bits 15:0 – ERR[15:0] ADC Setpoint Error - Signed two's complement

Notes: The individual bytes in this multibyte register can be accessed with the following register names:

- ADERRH: Accesses the high byte ADERR[15:8]
- ADERRL: Accesses the low byte ADERR[7:0]

33.5.21 ADLTH

Name: ADLTH
Offset: 0x1D0C

ADC Lower Threshold Register

ADLTH and ADUTH are compared with ADERR to set the UTHR and LTHR bits. Depending on the setting of the TMD bits, an interrupt may be triggered by the results of this comparison.

Bit	15	14	13	12	11	10	9	8
	LTH[15:8]							
Access	R/W	R/W	R/W	R/W	R/W	R/W	R/W	R/W
Reset	0	0	0	0	0	0	0	0
Bit	7	6	5	4	3	2	1	0
	LTH[7:0]							
Access	R/W	R/W	R/W	R/W	R/W	R/W	R/W	R/W
Reset	0	0	0	0	0	0	0	0

Bits 15:0 – LTH[15:0] ADC Lower Threshold - Signed two's complement

Notes: The individual bytes in this multibyte register can be accessed with the following register names:

- ADLTHH: Accesses the high byte ADLTH[15:8]
- ADLTHL: Accesses the low byte ADLTH[7:0]

33.5.22 ADUTH

Name: ADUTH
Offset: 0x1D0E

ADC Upper Threshold Register

ADLTH and ADUTH are compared with ADERR to set the UTHR and LTHR bits. Depending on the setting of the TMD bits, an interrupt may be triggered by the results of this comparison.

Bit	15	14	13	12	11	10	9	8
	UTH[15:8]							
Access	R/W	R/W	R/W	R/W	R/W	R/W	R/W	R/W
Reset	0	0	0	0	0	0	0	0
Bit	7	6	5	4	3	2	1	0
	UTH[7:0]							
Access	R/W	R/W	R/W	R/W	R/W	R/W	R/W	R/W
Reset	0	0	0	0	0	0	0	0

Bits 15:0 – UTH[15:0] ADC Upper Threshold - Signed two's complement

Notes: The individual bytes in this multibyte register can be accessed with the following register names:

- ADUTHH: Accesses the high byte ADUTH[15:8]
- ADUTHL: Accesses the low byte ADUTH[7:0]

33.5.23 ADACT

Name: ADACT
Offset: 0x1D2C

ADC Auto-Conversion Trigger Source Selection Register

Bit	7	6	5	4	3	2	1	0
				ACT[4:0]				
Access				R/W	R/W	R/W	R/W	R/W
Reset				0	0	0	0	0

Bits 4:0 – ACT[4:0] Auto-Conversion Trigger Select

Table 33-10. ADC Auto-Conversion Trigger Sources

ACT	Auto-Conversion Trigger Source
11111	Software write to ADPCH
11110	Software read of ADRESH
11101	Software read of ADERRH
11100–11010	Reserved
11001	CLC4_OUT
11000	CLC3_OUT
10111	CLC2_OUT
10110	CLC1_OUT
10101	Interrupt-on-change Interrupt Flag
10100	C2_OUT
10011	C1_OUT
10010	NCO1_OUT
10001–01110	Reserved
01101	PWM2S1P2_OUT
01100	PWM2S1P1_OUT
01011	PWM1S1P2_OUT
01010	PWM1S1P1_OUT
01001	CCP2_OUT
01000	CCP1_OUT
00111	Reserved
00110	TMR4_postscaled_OUT
00101	TMR3_overflow
00100	TMR2_postscaled_OUT
00011	TMR1_overflow
00010	TMR0_overflow
00001	Pin selected by ADACTPPS
00000	External Trigger Disabled

33.5.24 ADCGxA

Name: ADCGxA
Offset: 0x1D2E

ADC Channel Group Selection Port A

Bit	7	6	5	4	3	2	1	0
			CGA5	CGA4		CGA2	CGA1	CGA0
Access			R/W	R/W		R/W	R/W	R/W
Reset			0	0		0	0	0

Bits 4, 5 – CGAn Channel Group Selection Enable on RA Pins

Bits 0, 1, 2 – CGAn Channel Group Selection Enable on RA Pins

Note: Refer to the **“Pin Allocation Table”** for details about available pins per port.

33.5.25 ADCGxB

Name: ADCGxB
Offset: 0x1D2F

ADC Channel Group Selection Port B

Bit	7	6	5	4	3	2	1	0
	CGB7	CGB6	CGB5	CGB4				
Access	R/W	R/W	R/W	R/W				
Reset	0	0	0	0				

Bits 4, 5, 6, 7 - CGBn Channel Group Selection Enable on RB Pins

Note: Refer to the **"Pin Allocation Table"** for details about available pins per port.

33.5.26 ADGCx**Name:** ADGCx**Offset:** 0x1D30

ADC Channel Group Selection Port C

Bit	7	6	5	4	3	2	1	0
	CGC7	CGC6	CGC5	CGC4	CGC3	CGC2	CGC1	CGC0
Access	R/W	R/W	R/W	R/W	R/W	R/W	R/W	R/W
Reset	0	0	0	0	0	0	0	0

Bits 3, 4, 5, 6, 7 – CGCn Channel Group Selection Enable on RC Pins**Bits 0, 1, 2 – CGCn** Channel Group Selection Enable on RC Pins**Note:** Refer to the **“Pin Allocation Table”** for details about available pins per port.

33.6 Register Summary - ADC

Offset	Name	Bit Pos.	7	6	5	4	3	2	1	0
0x00 ... 0x1D0B	Reserved									
0x1D0C	ADLTH	7:0 15:8					LTH[7:0] LTH[15:8]			
0x1D0E	ADUTH	7:0 15:8					UTH[7:0] UTH[15:8]			
0x1D10	ADERR	7:0 15:8					ERR[7:0] ERR[15:8]			
0x1D12	ADSTPT	7:0 15:8					STPT[7:0] STPT[15:8]			
0x1D14	ADFLTR	7:0 15:8					FLTR[7:0] FLTR[15:8]			
0x1D16	ADACC	7:0 15:8 23:16					ACC[7:0] ACC[15:8]		ACC[17:16]	
0x1D19	ADCNT	7:0					CNT[7:0]			
0x1D1A	ADRPT	7:0					RPT[7:0]			
0x1D1B	ADPREV	7:0 15:8					PREV[7:0] PREV[15:8]			
0x1D1D	ADRES	7:0 15:8					RES[7:0] RES[15:8]			
0x1D1F	ADPCH	7:0						PCH[5:0]		
0x1D20	ADNCH	7:0						NCH[5:0]		
0x1D21	ADACQ	7:0 15:8					ACQ[7:0]		ACQ[12:8]	
0x1D23	ADCAP	7:0							CAP[4:0]	
0x1D24	ADPRE	7:0 15:8					PRE[7:0]		PRE[12:8]	
0x1D26	ADCON0	7:0	ON	CONT		CS		FM[1:0]	IC	GO
0x1D27	ADCON1	7:0	PPOL	IPEN	GPOL				PCSC	DSEN
0x1D28	ADCON2	7:0	PSIS		CRS[2:0]		ACLR		MD[2:0]	
0x1D29	ADCON3	7:0			CALC[2:0]		SOI		TMD[2:0]	
0x1D2A	ADSTAT	7:0	AOV	UTHR	LTHR	MATH			STAT[2:0]	
0x1D2B	ADREF	7:0							PREF[1:0]	
0x1D2C	ADACT	7:0						ACT[4:0]		
0x1D2D	ADCLK	7:0						CS[5:0]		
0x1D2E	ADCG1A	7:0			CGA5	CGA4		CGA2	CGA1	CGA0
0x1D2F	ADCG1B	7:0	CGB7	CGB6	CGB5	CGB4				
0x1D30	ADCG1C	7:0	CGC7	CGC6	CGC5	CGC4	CGC3	CGC2	CGC1	CGC0

34. DAC - Digital-to-Analog Converter Module

The Digital-to-Analog Converter (DAC) supplies a variable voltage reference, ratiometric with the input source, with programmable selectable output levels.

The positive and negative input references (DACxREF+ and DACxREF-) can each be selected from several sources.

The output of the DAC (DAC1OUTx) can be selected as a reference voltage to several other peripherals or routed to output pins.

The Digital-to-Analog Converter (DAC) is enabled by setting the [EN](#) bit.



Important: This family of devices has two DAC modules. The DAC1 module has a buffered output that can be connected to any of the designated DAC output pins. The DAC2 module has no output pins or buffer, and the output is only connected internally to the ADC and Comparator modules.

Figure 34-1. Digital-to-Analog Converter Block Diagram

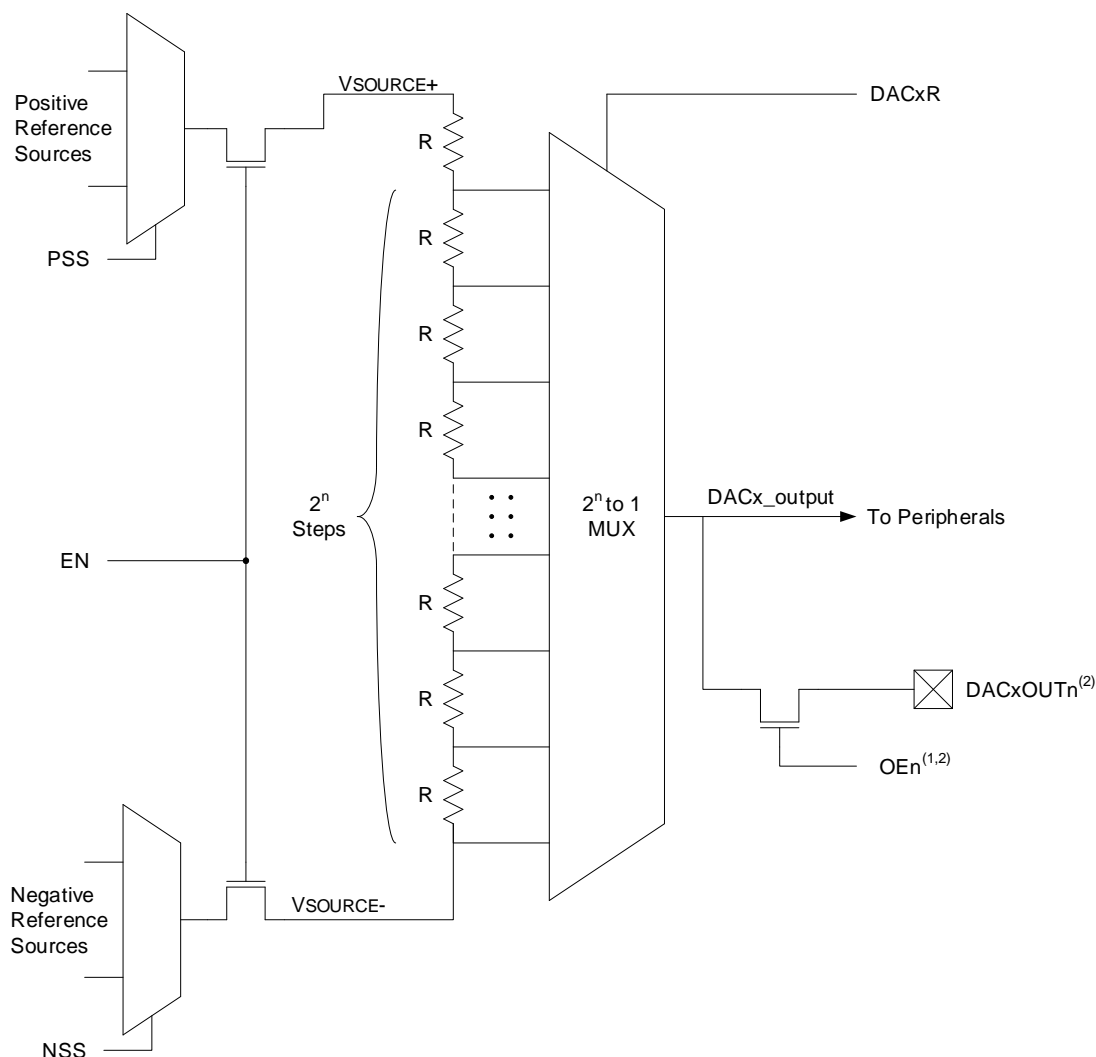

- Notes:**
1. The output enable bits are configured so that they act as a "one-hot" system, meaning only one DAC output can be enabled at a time.
 2. DAC2 has no output buffer; the output from DAC2 is only connected internally to the specified peripherals.

34.1 Output Voltage Selection

The DAC has 2^n voltage level ranges, where n is the number of bits in DACR. Each level is determined by the [DACxR](#) bits. The DAC output voltage can be determined by using [Equation 34-1](#).

Equation 34-1. DAC Output Equation

$$DACx_output = \left((V_{REF+} - V_{REF-}) \times \frac{DACR}{2^n} \right) + V_{REF-}$$

34.2 Ratiometric Output Level

The DAC output value is derived using a resistor ladder with each end of the ladder tied to a positive and negative voltage reference input source. If the voltage of either input source fluctuates, a similar fluctuation will result in the DAC output value. The value of the individual resistors within the ladder can be found in the **"Electrical Specifications"** chapter for each respective device.

34.3 Buffered DAC Output Range Selection

The DAC offers selectable output ranges that improve the output performance of the buffered DAC output (DAC1OUTx). Range selection allows module hardware to optimize the DAC buffer output by biasing the reference voltages toward either DACxREF+ (high range) or DACxREF- (low range). Range selection can be done automatically or through software control.

The DAC Buffer Automatic Range Select Enable ($\overline{\text{DACAUTOEN}}$) bit of the Configuration Words is used to select either user software-controlled ranging or automatic ranging via hardware control.

When $\overline{\text{DACAUTOEN}}$ is set ($\overline{\text{DACAUTOEN}} = 1$), the range is determined by the Buffer Reference Range Selection (REFRNG) bit in user software. When REFRNG is set (REFRNG = 1), the high range ($(V_{SS} + 1.0V)$ through V_{DD}) is selected as the voltage reference range. When REFRNG is clear (REFRNG = 0), the low range (V_{SS} through $(V_{DD} - 1.0V)$) is selected as the reference range.

When $\overline{\text{DACAUTOEN}}$ is clear ($\overline{\text{DACAUTOEN}} = 0$), module hardware monitors the DACxDATL register and automatically selects the appropriate range based on the DACxDAT value.



Important: To ensure the most accurate results, it is highly recommended to do the following:

- Enable the DAC Auto-Ranging feature in the Configuration Words ($\overline{\text{DACAUTOEN}} = 0$)
- Set the Charge Pump to Auto mode (CPCONbits.CPON = 'b10)
- Wait the required settling time when changing the DACxDATL values (see the “**Electrical Specifications**” section)

This allows module hardware to continuously monitor the DAC output and V_{DD} levels to ensure a stable, accurate result with little software overhead.

34.4 Operation During Sleep

When the device wakes from Sleep through an interrupt or a WWDT Time-out Reset, the contents of the DACxCON and DACxDATL registers are not affected. To minimize current consumption in Sleep mode, the voltage reference will be disabled.

34.5 Effects of a Reset

A device Reset affects the following:

- The DAC module is disabled
- The DAC output voltage is removed from the DACxOUTn pin(s)
- The DACxR bits are cleared

34.6 Register Definitions: DAC Control

Long bit name prefixes for the DAC are shown in the table below. Refer to the “**Long Bit Names**” section in the “**Register and Bit Naming Conventions**” chapter for more information.

Table 34-1. DAC Long Bit Name Prefixes

Peripheral	Bit Name Prefix
DAC1	DAC1
DAC2	DAC2

34.6.1 DACxCON

Name: DACxCON

Offset: 0x088C

Digital-to-Analog Converter Control Register

Bit	7	6	5	4	3	2	1	0
	EN	REFRNG	OE[1:0]		PSS[1:0]			NSS
Access	R/W	R/W	R/W	R/W	R/W	R/W		R/W
Reset	0	0	0	0	0	0		0

Bit 7 – EN DAC Enable

Value	Description
1	DAC is enabled
0	DAC is disabled

Bit 6 – REFRNG Buffer Reference Range Selection⁽¹⁾

Value	Condition	Description
x	DACAUTOEN = 0	Automatic ranging enabled; the REFRNG bit is ignored
1	DACAUTOEN = 1	Range optimized for voltages from ($V_{SS} + 1.0V$) through V_{DD}
0	DACAUTOEN = 1	Range optimized for voltages from V_{SS} through ($V_{DD} - 1.0V$)

Bits 5:4 – OE[1:0] DAC Output Enable

OE	DAC1
11	DAC1OUTx is disabled
10	DAC1OUT2 is enabled on pin RA2 only
01	DAC1OUT1 is enabled on pin RA0 only
00	DAC1OUTx is disabled

Bits 3:2 – PSS[1:0] DAC Positive Reference Selection

PSS	DAC Positive Reference
11	Reserved
10	FVR Buffer 2
01	V_{REF+}
00	V_{DD}

Bit 0 – NSS DAC Negative Reference Selection

NSS	DAC Negative Reference
1	V_{REF-}
0	V_{SS}

Note:

- The REFRNG bit only applies to DAC1OUT1/2.

34.6.2 DACxCON

Name: DACxCON
Offset: 0x0890



Important: This instance of the DAC module has no output pins or buffer; the output of this DAC is only connected internally to be used with the Comparator and OPA modules.

Digital-to-Analog Converter Control Register

Bit	7	6	5	4	3	2	1	0
	EN				PSS[1:0]			NSS
Access	R/W				R/W	R/W		R/W
Reset	0				0	0		0

Bit 7 - EN DAC Enable

Value	Description
1	DAC is enabled
0	DAC is disabled

Bits 3:2 - PSS[1:0] DAC Positive Reference Selection

PSS	DAC Positive Reference
11	Reserved
10	FVR Buffer 2
01	V_{REF+}
00	V_{DD}

Bit 0 - NSS DAC Negative Reference Selection

NSS	DAC Negative Reference
1	V_{REF-}
0	V_{SS}

34.6.3 DACxDATL

Name: DACxDATL
Offset: 0x088D

Digital-to-Analog Converter Data Register

Bit	7	6	5	4	3	2	1	0
	DACxR[7:0]							
Access	R/W	R/W	R/W	R/W	R/W	R/W	R/W	R/W
Reset	0	0	0	0	0	0	0	0

Bits 7:0 – DACxR[7:0] Data Input Bits for DAC Value

34.6.4 DACxDATL

Name: DACxDATL
Offset: 0x0891

Digital-to-Analog Converter Data Register

Bit	7	6	5	4	3	2	1	0
	DACxR[7:0]							
Access	R/W	R/W	R/W	R/W	R/W	R/W	R/W	R/W
Reset	0	0	0	0	0	0	0	0

Bits 7:0 – DACxR[7:0] Data Input Bits for DAC Value

34.7 Register Summary - DAC

Offset	Name	Bit Pos.	7	6	5	4	3	2	1	0
0x00 ...	Reserved									
0x088B										
0x088C	DAC1CON	7:0	EN	REFRNG	OE[1:0]		PSS[1:0]			NSS
0x088D	DAC1DATL	7:0	DAC1R[7:0]							
0x088E ...	Reserved									
0x088F										
0x0890	DAC2CON	7:0	EN				PSS[1:0]			NSS
0x0891	DAC2DATL	7:0	DAC2R[7:0]							

35. CMP - Comparator Module

Comparators are used to interface analog circuits to a digital circuit by comparing two analog voltages and providing a digital indication of their relative magnitudes. Comparators are very useful mixed signal building blocks because they provide analog functionality independent of program execution.

The analog comparator module includes the following features:

- Programmable input selection
- Programmable output polarity
- Rising/falling output edge interrupts
- Wake-up from Sleep
- Selectable voltage reference
- ADC auto-trigger
- Inter-connections with other available modules (e.g., timer clocks)

35.1 Comparator Overview

A single comparator is shown in Figure 35-1 along with the relationship between the analog input levels and the digital output. When the analog voltage at V_{IN+} is less than the analog voltage at V_{IN-} , the output of the comparator is a digital low level. When the analog voltage at V_{IN+} is greater than the analog voltage at V_{IN-} , the output of the comparator is a digital high level.

Figure 35-1. Single Comparator

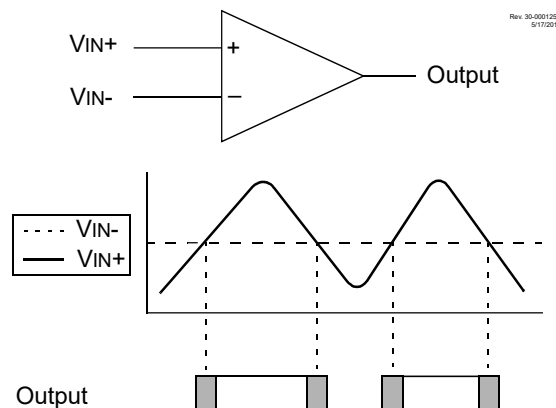

Note:

1. The black areas of the output of the comparator represent the uncertainty due to input offsets and response time.

Figure 35-2. Comparator Module Simplified Block Diagram

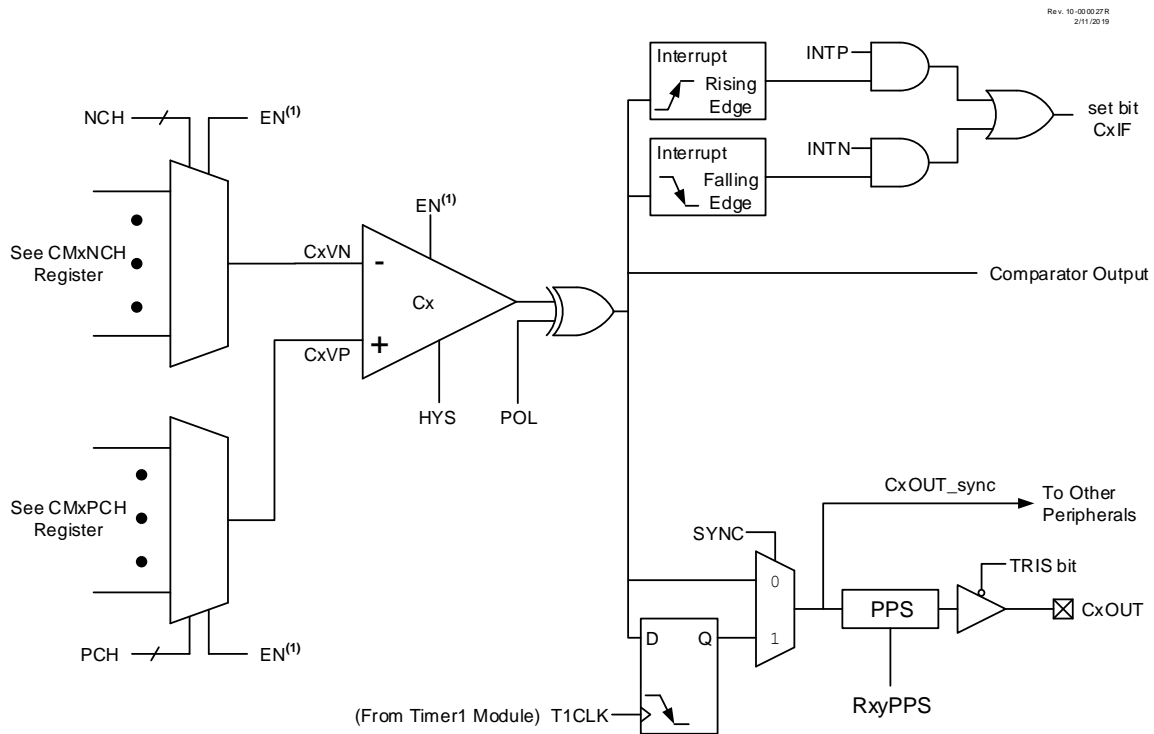

Note 1: When EN = 0, all multiplexer inputs are disconnected and the Comparator will produce a '0' at the output.

35.2 Comparator Control

Each comparator has two control registers: CMxCON0 and CMxCON1.

The **CMxCON0** register contains Control and Status bits for the following:

- Enable
- Output
- Output Polarity
- Hysteresis Enable
- Timer1 Output Synchronization

The **CMxCON1** register contains Control bits for the following:

- Interrupt on Positive/Negative Edge Enables

The CMxPCH and CMxNCH registers are used to select the positive and negative input channels, respectively.

35.2.1 Comparator Enable

Setting the **EN** bit enables the comparator for operation. Clearing the EN bit disables the comparator, resulting in minimum current consumption.

35.2.2 Comparator Output

The output of the comparator can be monitored in two different registers. Each output can be read individually by reading the **OUT** bit. Outputs of all the comparators can be collectively accessed by reading the **CMOUT** register.

The comparator output can also be routed to an external pin through the RxyPPS register. Refer to the **“PPS - Peripheral Pin Select Module”** chapter for more details. The corresponding TRIS bit must be clear to enable the pin as an output.



Important: The internal output of the comparator is latched with each instruction cycle. Unless otherwise specified, external outputs are not latched.

35.2.3 Comparator Output Polarity

Inverting the output of the comparator is functionally equivalent to swapping the comparator inputs. The polarity of the comparator output can be inverted by setting the POL bit. Clearing the POL bit results in a noninverted output. Table 35-1 shows the Output state versus Input conditions, including polarity control.

Table 35-1. Comparator Output State vs. Input Conditions

Input Condition	POL	OUT
$CxVn > CxVp$	0	0
$CxVn < CxVp$	0	1
$CxVn > CxVp$	1	1
$CxVn < CxVp$	1	0

35.3 Comparator Output Synchronization

The output from a comparator can be synchronized with Timer1 by setting the SYNC bit.

Once enabled, the comparator output is latched on the falling edge of the Timer1 source clock. If a prescaler is used with Timer1, the comparator output is latched after the prescaling function. To prevent a Race condition, the comparator output is latched on the falling edge of the Timer1 clock source and Timer1 increments on the rising edge of its clock source. A simplified block diagram of the comparator module is shown in Figure 35-2. Refer to the **“TMR1 - Timer1 Module with Gate Control”** chapter for more details.

35.4 Comparator Hysteresis

A selectable amount of separation voltage can be added to the input pins of each comparator to provide a hysteresis function to the overall operation. Hysteresis is enabled by setting the HYS bit.

See the **“Comparator Specifications”** section for more information.

35.5 Comparator Interrupt

An interrupt can be generated for every rising or falling edge of the comparator output.

When either edge detector is triggered and its associated enable bit is set (INTP and/or INTN bits), the Corresponding Interrupt Flag bit (CxIF bit of the respective PIR register) will be set.

To enable the interrupt, the following bits must be set:

- EN bit
- INTP bit (for a rising edge detection)
- INTN bit (for a falling edge detection)
- CxIE bit of the respective PIE register
- GIE bit of the INTCON0 register

The associated interrupt flag bit, CxIF bit of the respective PIR register, must be cleared in software to successfully detect another edge.



Important: Although a comparator is disabled, an interrupt will be generated by changing the output polarity with the [POL](#) bit.

35.6 Comparator Positive Input Selection

Configuring the [PCH](#) bits direct an internal voltage reference or an analog pin to the noninverting input of the comparator.

Any time the comparator is disabled ($EN = 0$), all comparator inputs are disabled.

35.7 Comparator Negative Input Selection

The [NCH](#) bits direct an analog input pin, internal reference voltage or analog ground to the inverting input of the comparator.



Important: To use $CxINy+$ and $CxINy-$ pins as analog input, the appropriate bits must be set in the ANSEL register and the corresponding TRIS bits must also be set to disable the output drivers.

35.8 Comparator Response Time

The comparator output is indeterminate for a period of time after the change of an input source or the selection of a new reference voltage. This period is referred to as the response time. The response time of the comparator differs from the settling time of the voltage reference. Therefore, both of these times must be considered when determining the total response time to a comparator input change. See the Comparator and Voltage Reference Specifications in the “[Comparator Specifications](#)” and “[Fixed Voltage Reference \(FVR\) Specifications](#)” sections for more details.

35.9 Analog Input Connection Considerations

A simplified circuit for an analog input is shown in [Figure 35-3](#). Since the analog input pins share their connection with a digital input, they have reverse biased ESD protection diodes to V_{DD} and V_{SS} . The analog input, therefore, must be between V_{SS} and V_{DD} . If the input voltage deviates from this range by more than 0.6V in either direction, one of the diodes is forward biased and abnormal behavior may occur.

A maximum source impedance of 10 k Ω is recommended for the analog sources. Also, any external component connected to an analog input pin, such as a capacitor or a Zener diode, will have very little leakage current to minimize corrupting the result.

Notes:

1. When reading a PORT register, all pins configured as analog inputs will read as a '0'. Pins configured as digital inputs will convert as an analog input, according to the input specification.
2. Analog levels on any pin defined as a digital input may cause the input buffer to consume more current than specified.

Figure 35-3. Analog Input Model

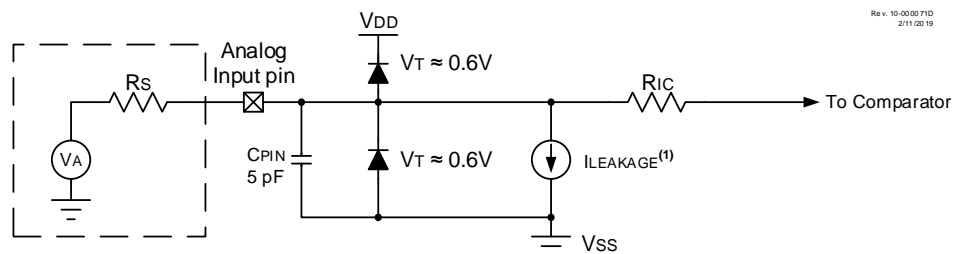

Legend: CPIN = Input Capacitance
 ILEAKAGE = Leakage Current at the pin due to various junctions
 RIC = Interconnect Resistance
 RS = Source Impedance
 VA = Analog Voltage
 VT = Diode Forward Voltage

Note:
 1. See the "Electrical Specifications" chapter.

35.10 Operation in Sleep Mode

The comparator module can operate during Sleep. A comparator interrupt will wake the device from Sleep. The CxIE bits of the respective PIE register must be set to enable comparator interrupts.

The comparator clock source is based on the Timer1 clock source. If the Timer1 clock source is either the system clock (F_{OSC}) or the instruction clock ($F_{OSC}/4$), Timer1 will not operate during Sleep, and synchronized comparator outputs will not operate.

35.11 ADC Auto-Trigger Source

The output of the comparator module can be used to trigger an ADC conversion. When the ADACT register is set to trigger on a comparator output, an ADC conversion will trigger when the comparator output goes high.

35.12 Register Definitions: Comparator Control

Long bit name prefixes for the Comparator peripherals are shown in the table below. Refer to the "Long Bit Names" section in the "Register and Bit Naming Conventions" chapter for more information.

Table 35-2. Comparator Long Bit Name Prefixes

Peripheral	Bit Name Prefix
C1	C1
C2	C2

35.12.1 CMxCON0

Name: CMxCON0
Offset: 0x080C,0x0810

Comparator Control Register 0

Bit	7	6	5	4	3	2	1	0
	EN	OUT		POL			HYS	SYNC
Access	R/W	R		R/W			R/W	R/W
Reset	0	0		0			0	0

Bit 7 – EN Comparator Enable

Value	Description
1	Comparator is enabled
0	Comparator is disabled and consumes no active power

Bit 6 – OUT Comparator Output

Value	Condition	Description
1	If POL = 0 (noninverted polarity):	CxVP > CxVN
0	If POL = 0 (noninverted polarity):	CxVP < CxVN
1	If POL = 1 (inverted polarity):	CxVP < CxVN
0	If POL = 1 (inverted polarity):	CxVP > CxVN

Bit 4 – POL Comparator Output Polarity Select

Value	Description
1	Comparator output is inverted
0	Comparator output is not inverted

Bit 1 – HYS Comparator Hysteresis Enable

Value	Description
1	Comparator hysteresis enabled
0	Comparator hysteresis disabled

Bit 0 – SYNC Comparator Output Synchronous Mode

Value	Description
1	Comparator output to Timer1 and I/O pin is synchronous to changes on Timer1 clock source. Output updated on the falling edge of Timer1 clock source.
0	Comparator output to Timer1 and I/O pin is asynchronous

35.12.2 CMxCON1

Name: CMxCON1
Offset: 0x080D,0x0811

Comparator Control Register 1

Bit	7	6	5	4	3	2	1	0
							INTP	INTN
Access							R/W	R/W
Reset							0	0

Bit 1 – INTP Comparator Interrupt on Positive-Going Edge Enable

Value	Description
1	The CxIF interrupt flag will be set upon a positive-going edge of the CxOUT bit
0	No interrupt flag will be set on a positive-going edge of the CxOUT bit

Bit 0 – INTN Comparator Interrupt on Negative-Going Edge Enable

Value	Description
1	The CxIF interrupt flag will be set upon a negative-going edge of the CxOUT bit
0	No interrupt flag will be set on a negative-going edge of the CxOUT bit

35.12.3 CMxNCH

Name: CMxNCH
Offset: 0x080E,0x0812

Comparator Inverting Channel Select Register

Bit	7	6	5	4	3	2	1	0
						NCH[2:0]		
Access						R/W	R/W	R/W
Reset						0	0	0

Bits 2:0 – NCH[2:0] Comparator Inverting Input Channel Select

NCH	Negative Input Sources
111	V _{SS}
110	FVR_Buffer2
101	NCH not connected
100	NCH not connected
011	CxIN3-
010	CxIN2-
001	CxIN1-
000	CxIN0-

35.12.4 CMxPCH

Name: CMxPCH
Offset: 0x080F,0x0813

Comparator Noninverting Channel Select Register

Bit	7	6	5	4	3	2	1	0
						PCH[2:0]		
Access						R/W	R/W	R/W
Reset						0	0	0

Bits 2:0 – PCH[2:0] Comparator Noninverting Input Channel Select

PCH	Positive Input Sources
111	V _{SS}
110	FVR_Buffer2
101	DAC2OUT
100	DAC1OUT
011	PCH not connected
010	PCH not connected
001	PCH not connected
000	CxIN0+

35.12.5 CMOUT

Name: CMOUT
Offset: 0x081F

Comparator Output Register

Bit	7	6	5	4	3	2	1	0
							C2OUT	C1OUT
Access							R	R
Reset							0	0

Bits 0, 1 – CxOUT Mirror copy of the CMxCON0.OUT

35.13 Register Summary - Comparator

Offset	Name	Bit Pos.	7	6	5	4	3	2	1	0
0x00 ...	Reserved									
0x080B										
0x080C	CM1CON0	7:0	EN	OUT		POL			HYS	SYNC
0x080D	CM1CON1	7:0							INTP	INTN
0x080E	CM1NCH	7:0							NCH[2:0]	
0x080F	CM1PCH	7:0							PCH[2:0]	
0x0810	CM2CON0	7:0	EN	OUT		POL			HYS	SYNC
0x0811	CM2CON1	7:0							INTP	INTN
0x0812	CM2NCH	7:0							NCH[2:0]	
0x0813	CM2PCH	7:0							PCH[2:0]	
0x0814 ...	Reserved									
0x081E										
0x081F	CMOUT	7:0							C2OUT	C1OUT

36. FVR - Fixed Voltage Reference

The Fixed Voltage Reference (FVR) is a stable voltage reference, independent of V_{DD} , with 1.024V, 2.048V or 4.096V selectable output levels. The output of the FVR can be configured to supply a reference voltage to analog peripherals such as those listed below.

- ADC input channel
- ADC positive reference
- Comparator input
- Digital-to-Analog Converter (DAC)

The FVR can be enabled by setting the **EN** bit to '1'.

Note: Fixed Voltage Reference output cannot exceed V_{DD} .

36.1 Independent Gain Amplifiers

The output of the FVR is routed through two independent programmable gain amplifiers. Each amplifier can be programmed for a gain of 1x, 2x or 4x, to produce the three possible voltage levels.

The **ADFVR** bits are used to enable and configure the gain amplifier settings for the reference supplied to the ADC module. Refer to the **"ADC - Analog-to-Digital Converter with Computation Module"** chapter for additional information.

The **CDAFVR** bits are used to enable and configure the gain amplifier settings for the reference supplied to the DAC and comparator modules. Refer to the **"DAC - Digital-to-Analog Converter Module"** and **"CMP - Comparator Module"** chapters for additional information.

Refer to the figure below for the block diagram of the FVR module.

Figure 36-1. Fixed Voltage Reference Block Diagram

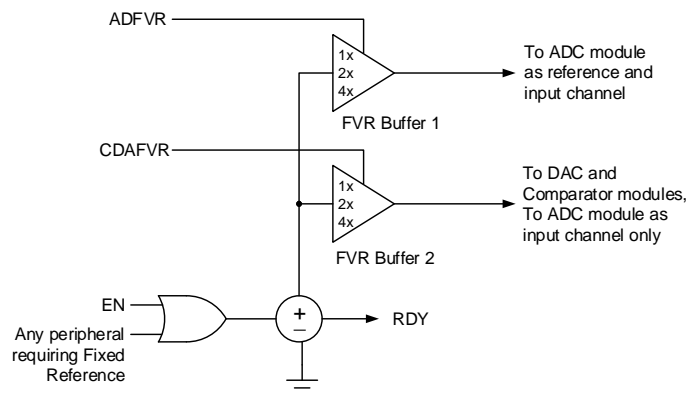

36.2 FVR Stabilization Period

When the Fixed Voltage Reference module is enabled, it requires time for the reference and amplifier circuits to stabilize. Once the circuits stabilize and are ready for use, the **RDY** bit will be set.

36.3 Register Definitions: FVR

Long bit name prefixes for the FVR peripherals are shown in the following table. Refer to the **"Long Bit Names"** section in the **"Register and Bits Naming Conventions"** chapter for more information.

Table 36-1. FVR Long Bit Name Prefixes

Peripheral	Bit Name Prefix
FVR	FVR

36.3.1 FVRCON

Name: FVRCON
Offset: 0x020C

FVR Control Register



Important: This register is shared between the Fixed Voltage Reference (FVR) module and the temperature indicator module.

Bit	7	6	5	4	3	2	1	0
	EN	RDY	TSEN	TSRNG	CDAFVR[1:0]		ADFVR[1:0]	
Access	R/W	R	R/W	R/W	R/W	R/W	R/W	R/W
Reset	0	q	0	0	0	0	0	0

Bit 7 - EN Fixed Voltage Reference Enable

Value	Description
1	Enables module
0	Disables module

Bit 6 - RDY Fixed Voltage Reference Ready Flag

Value	Description
1	Fixed Voltage Reference output is ready for use
0	Fixed Voltage Reference output is not ready for use or not enabled

Bit 5 - TSEN Temperature Indicator Enable

Value	Description
1	Temperature Indicator is enabled
0	Temperature Indicator is disabled

Bit 4 - TSRNG Temperature Indicator Range Selection

Value	Description
1	$V_{OUT} = 3V_T$ (High Range)
0	$V_{OUT} = 2V_T$ (Low Range)

Bits 3:2 - CDAFVR[1:0] FVR Buffer 2 Gain Selection⁽¹⁾

Value	Description
11	FVR Buffer 2 Gain is 4x, (4.096V) ⁽³⁾
10	FVR Buffer 2 Gain is 2x, (2.048V) ⁽³⁾
01	FVR Buffer 2 Gain is 1x, (1.024V)
00	FVR Buffer 2 is OFF

Bits 1:0 - ADFVR[1:0] FVR Buffer 1 Gain Selection⁽²⁾

Value	Description
11	FVR Buffer 1 Gain is 4x, (4.096V) ⁽³⁾
10	FVR Buffer 1 Gain is 2x, (2.048V) ⁽³⁾
01	FVR Buffer 1 Gain is 1x, (1.024V)
00	FVR Buffer 1 is OFF

Notes:

1. This output goes to the DAC and comparator modules and to the ADC module as an input channel only.
2. This output goes to the ADC module as a reference and as an input channel.
3. Fixed Voltage Reference output cannot exceed V_{DD} .

36.4 Register Summary - FVR

Offset	Name	Bit Pos.	7	6	5	4	3	2	1	0
0x00	Reserved									
...										
0x020B										
0x020C	FVRCON	7:0	EN	RDY	TSEN	TSRNG	CDAFVR[1:0]		ADFVR[1:0]	

37. Temperature Indicator Module

This family of devices is equipped with a temperature circuit designed to measure the operating temperature of the silicon die. The temperature indicator module provides a temperature-dependent voltage that can be measured by the internal Analog-to-Digital Converter.

The circuit's range of operating temperature falls between -40°C and $+125^{\circ}\text{C}$. The circuit may be used as a temperature threshold detector or a more accurate temperature indicator, depending on the level of calibration performed. A one-point calibration allows the circuit to indicate a temperature closely surrounding that point. A two-point calibration allows the circuit to sense the entire range of temperature more accurately.

Microchip tests each device during manufacturing and provides the gain, offset, and Temperature Indicator ADC values at 90°C , for both High and Low Range operation.

37.1 Module Operation

The temperature indicator module consists of a temperature-sensing circuit that provides a voltage to the device ADC. The analog voltage output varies inversely to the device temperature. The output of the temperature indicator is referred to as V_{MEAS} .

The following figure shows a simplified block diagram of the temperature indicator module.

Figure 37-1. Temperature Indicator Module Block Diagram

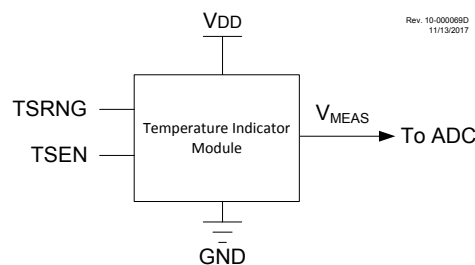

The output of the circuit is measured using the internal Analog-to-Digital Converter. A channel is reserved for the temperature circuit output. Refer to the **“ADC - Analog-to-Digital Converter with Computation Module”** chapter for more details.

The ON/OFF bit for the module is located in the FVRCON register. The circuit is enabled by setting the **TSEN** bit. When the module is disabled, the circuit draws no current. Refer to the **“FVR - Fixed Reference Voltage”** chapter for more details.

37.1.1 Temperature Indicator Range

The temperature indicator circuit operates in either high or low range. The high range, selected by setting the **TSRNG** bit, provides a wider output voltage. This provides more resolution over the temperature range. High range requires a higher bias voltage to operate and thus, a higher V_{DD} is needed. The low range is selected by clearing the **TSRNG** bit. The low range generates a lower sensor voltage and thus, a lower V_{DD} voltage is needed to operate the circuit.

The output voltage of the sensor is the highest value at -40°C and the lowest value at $+125^{\circ}\text{C}$.

- **High Range:** The high range is used in applications with the reference for the ADC, $V_{\text{REF}} = 2.048\text{V}$. This range may not be suitable for battery-powered applications.
- **Low Range:** This mode is useful in applications in which the V_{DD} is too low for high-range operation. The V_{DD} in this mode can be as low as 1.8V. However, V_{DD} must be at least 0.5V higher than the maximum sensor voltage depending on the expected low operating temperature.



Important: The standard parameters for the Temperature Indicator for both high range and low range are stored in the DIA table. Refer to the DIA table in the **“Memory Organization”** chapter for more details. Additionally, the Temperature Indicator sensitivity parameter (M_V) for both high range and low range is located in the **“Electrical Specifications”** section.

37.1.2 Minimum Operating V_{DD}

When the temperature circuit is operated in low range, the device may be operated at any operating voltage that is within the device specifications. When the temperature circuit is operated in high range, the device operating voltage, V_{DD} , must be high enough to ensure that the temperature circuit is correctly biased.

The following table shows the recommended minimum V_{DD} vs. Range setting.

Table 37-1. Recommended V_{DD} vs. Range

Min. V_{DD} , TSRNG = 1 (High Range)	Min. V_{DD} , TSRNG = 0 (Low Range)
≥ 2.5	≥ 1.8

37.2 Temperature Calculation

This section describes the steps involved in calculating the die temperature, T_{MEAS} :

1. Obtain the ADC count value of the measured analog voltage: The analog output voltage, V_{MEAS} , is converted to a digital count value by the Analog-to-Digital Converter (ADC) and is referred to as ADC_{MEAS} .
2. Obtain the Gain value from the DIA table. This parameter is TSLR1 for the low range setting or TSHR1 for the high range setting of the temperature indicator module. Refer to the DIA table in the **“Memory Organization”** chapter for more details.
3. Obtain the Offset value from the DIA table. This parameter is TSLR3 for the low range setting or TSHR3 for the high range setting of the temperature indicator module. Refer to the DIA table in the **“Memory Organization”** chapter for more details.

The following equation provides an estimate for the die temperature based on the above parameters:

Equation 37-1. Sensor Temperature (in °C)

$$T_{MEAS} = \frac{\frac{(ADC_{MEAS} \times Gain)}{256} + Offset}{10}$$

Where:

ADC_{MEAS} = ADC reading at temperature being estimated

Gain = Gain value stored in the DIA table

Offset = Offset value stored in the DIA table

Note: It is recommended to take the average of ten measurements of ADC_{MEAS} to reduce noise and improve accuracy.

Example 37-1. Temperature Calculation (C)

```
// offset is int16_t data type
// gain is int16_t data type
// ADC_MEAS is uint16_t data type
// Temp_in_C is int24_t data type

ADC_MEAS = ((ADRESH << 8) + ADRESL); // Store the ADC Result
```

```

Temp_in_C = (int24_t)(ADC_MEAS) * gain; // Multiply the ADC Result by
// Gain and store the result
// in a signed variable
Temp_in_C = Temp_in_C / 256; // Divide (ADC Result * Gain) by 256
Temp_in_C = Temp_in_C + offset; // Add (Offset) to the result
Temp_in_C = Temp_in_C / 10; // Divide the result by 10 and store
// the calculated temperature

```



Important: If the application requires more precise temperature measurement, additional calibrations steps will be necessary. For these applications, two-point or three-point calibration is recommended. For additional information on two-point calibration method, refer to the following Microchip application note, available at the corporate website (www.microchip.com):

- AN2798, "Using the PIC16F/PIC18F Ground Referenced Temperature Indicator Module"

37.3 ADC Acquisition Time

To ensure accurate temperature measurements, the user must wait a certain minimum acquisition time (parameter TS01) after the temperature indicator output is selected as ADC input. This is required for the ADC sampling circuit to settle before the conversion is performed.

Note: Parameter TS01 can be found in the Temperature Indicator Requirements table of the "Electrical Specifications" chapter.

37.4 Register Definitions: Temperature Indicator

37.4.1 FVRCON

Name: FVRCON
Offset: 0x020C

FVR Control Register



Important: This register is shared between the Fixed Voltage Reference (FVR) module and the temperature indicator module.

Bit	7	6	5	4	3	2	1	0
	EN	RDY	TSEN	TSRNG	CDAFVR[1:0]		ADFVR[1:0]	
Access	R/W	R	R/W	R/W	R/W	R/W	R/W	R/W
Reset	0	q	0	0	0	0	0	0

Bit 7 – EN Fixed Voltage Reference Enable

Value	Description
1	Enables module
0	Disables module

Bit 6 – RDY Fixed Voltage Reference Ready Flag

Value	Description
1	Fixed Voltage Reference output is ready for use
0	Fixed Voltage Reference output is not ready for use or not enabled

Bit 5 – TSEN Temperature Indicator Enable

Value	Description
1	Temperature Indicator is enabled
0	Temperature Indicator is disabled

Bit 4 – TSRNG Temperature Indicator Range Selection

Value	Description
1	$V_{OUT} = 3V_T$ (High Range)
0	$V_{OUT} = 2V_T$ (Low Range)

Bits 3:2 – CDAFVR[1:0] FVR Buffer 2 Gain Selection⁽¹⁾

Value	Description
11	FVR Buffer 2 Gain is 4x, (4.096V) ⁽³⁾
10	FVR Buffer 2 Gain is 2x, (2.048V) ⁽³⁾
01	FVR Buffer 2 Gain is 1x, (1.024V)
00	FVR Buffer 2 is OFF

Bits 1:0 – ADFVR[1:0] FVR Buffer 1 Gain Selection⁽²⁾

Value	Description
11	FVR Buffer 1 Gain is 4x, (4.096V) ⁽³⁾
10	FVR Buffer 1 Gain is 2x, (2.048V) ⁽³⁾
01	FVR Buffer 1 Gain is 1x, (1.024V)
00	FVR Buffer 1 is OFF

Notes:

1. This output goes to the DAC and comparator modules and to the ADC module as an input channel only.
2. This output goes to the ADC module as a reference and as an input channel.
3. Fixed Voltage Reference output cannot exceed V_{DD} .

37.5 Register Summary - Temperature Indicator

Offset	Name	Bit Pos.	7	6	5	4	3	2	1	0
0x00 ...	Reserved									
0x020B 0x020C	FVRCON	7:0	EN	RDY	TSEN	TSRNG	CDAFVR[1:0]		ADFVR[1:0]	

38. ZCD - Zero-Cross Detection Module

The ZCD module detects when an A/C signal crosses through the ground potential. The actual zero-crossing threshold is the zero-crossing reference voltage, Z_{CPINV} , which is typically 0.75V above ground.

The connection to the signal to be detected is through a series current-limiting resistor. The module applies a current source or sink to the ZCD pin to maintain a constant voltage on the pin, thereby preventing the pin voltage from forward biasing the ESD protection diodes. When the applied voltage is greater than the reference voltage, the module sinks current. When the applied voltage is less than the reference voltage, the module sources current. The current source and sink action keeps the pin voltage constant over the full range of the applied voltage. The ZCD module is shown in the following simplified block diagram.

Figure 38-1. Simplified ZCD Block Diagram

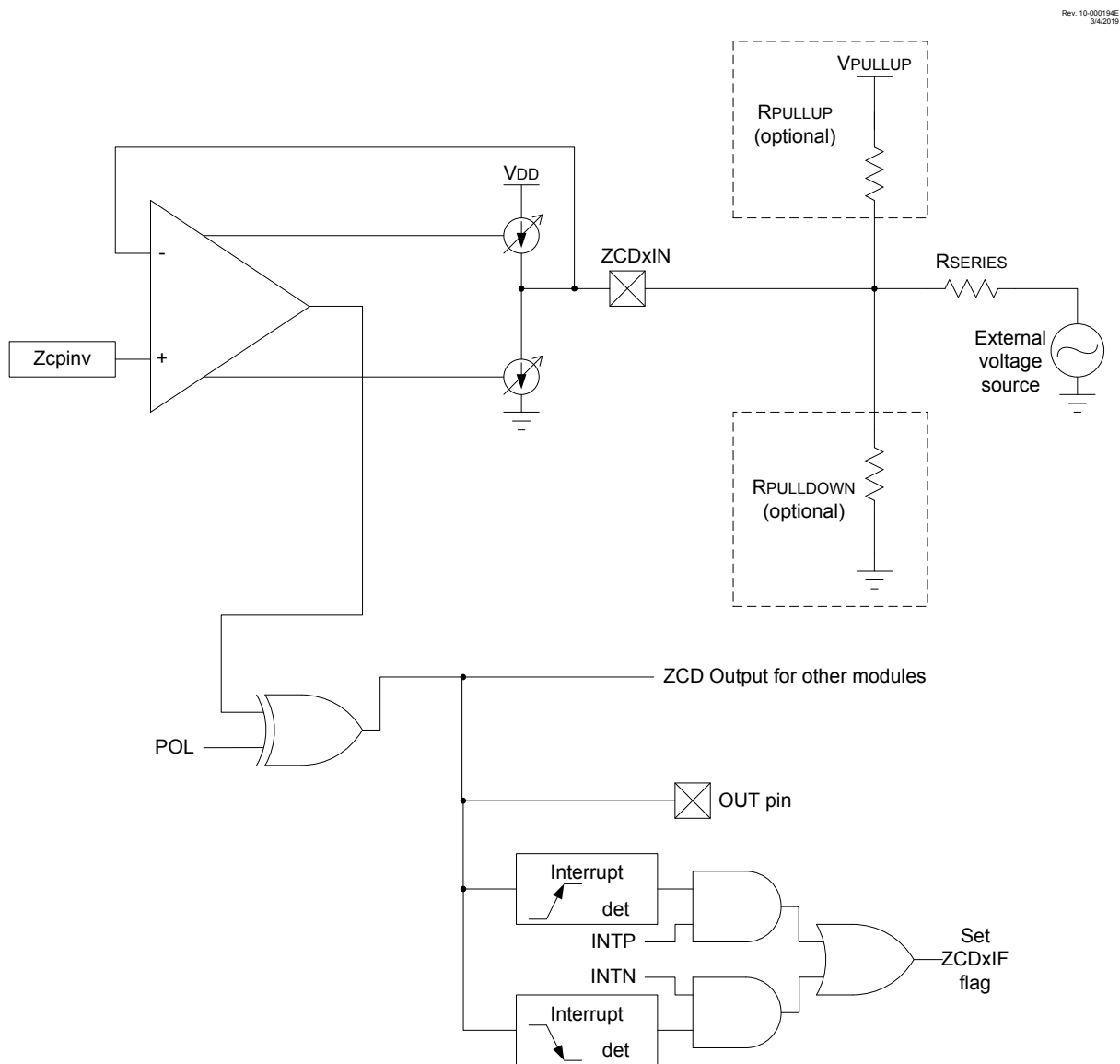

Rev. 10-000194E
3/4/2019

The ZCD module is useful when monitoring an A/C waveform for, but not limited to, the following purposes:

- A/C period measurement
- Accurate long term time measurement
- Dimmer phase delayed drive
- Low EMI cycle switching

38.1 External Resistor Selection

The ZCD module requires a current-limiting resistor in series with the external voltage source. The impedance and rating of this resistor depends on the external source peak voltage. Select a resistor value that will drop all of the peak voltage when the current through the resistor is less than the maximum input current (ZC02). Refer to the **“Electrical Specifications”** chapter for more details. Make sure that the ZCD I/O pin internal weak pull-up is disabled so it does not interfere with the current source and sink.

Equation 38-1. External Resistor

$$R_{SERIES} = \frac{V_{PEAK}}{I_{ZCD}}$$

Figure 38-2. External Voltage Source

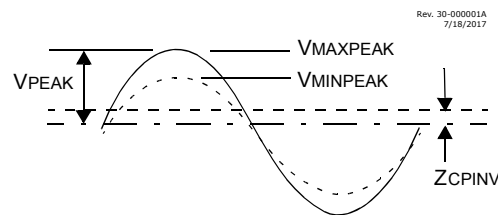

38.2 ZCD Logic Output

The ZCD module includes a Status bit, which can be read to determine whether the current source or sink is active. The **OUT** bit is set when the current sink is active and is cleared when the current source is active. The **OUT** bit is affected by the polarity bit.

The **OUT** signal can also be used as input to other modules. This is controlled by the registers of the corresponding module.

38.3 ZCD Logic Polarity

The **POL** bit inverts the **OUT** bit relative to the current source and sink output. When the **POL** bit is set, an **OUT** high indicates that the current source is active and a low output indicates that the current sink is active. The **POL** bit affects the ZCD interrupts.

38.4 ZCD Interrupts

An interrupt will be generated upon a change in the ZCD logic output when the appropriate interrupt enables are set. The ZCD module has a rising edge detector and a falling edge detector.

The **ZCDIF** bit of the **PIRx** register will be set when either edge detector is triggered and its associated enable bit is set. The **INTP** enables rising edge interrupts and the **INTN** bit enables falling edge interrupts.

To fully enable the interrupt, the following bits must be set:

- **ZCDIE** bit of the **PIEx** register
- **INTP** bit for rising edge detection

- INTN bit for falling edge detection
- GIEL and GIE bits of the INTCON0 register

Changing the POL bit will cause an interrupt, regardless of the level of the SEN bit.

The ZCDIF bit of the PIRx register must be cleared in software as part of the interrupt service. If another edge is detected while this flag is being cleared, the flag will still be set at the end of the sequence.

38.5 Correction for Z_{CPINV} Offset

The actual voltage at which the ZCD switches is the reference voltage at the noninverting input of the ZCD op amp. For external voltage source waveforms other than square waves, this voltage offset from zero causes the zero-cross event to occur either too early or too late.

38.5.1 Correction by AC Coupling

When the external voltage source is sinusoidal, the effects of the Z_{CPINV} offset can be eliminated by isolating the external voltage source from the ZCD pin with a capacitor, in addition to the voltage reducing resistor. The capacitor will cause a phase shift resulting in the ZCD output switch in advance of the actual zero-crossing event. The phase shift will be the same for both rising and falling zero-crossings, which can be compensated for by either delaying the CPU response to the ZCD switch by a timer or other means or selecting a capacitor value large enough that the phase shift is negligible.

To determine the series resistor and capacitor values for this configuration, start by computing the impedance, Z , to obtain a peak current less than the maximum input current (ZC02). Refer to the "**Electrical Specifications**" chapter for more details. Next, arbitrarily select a suitably large nonpolar capacitor and compute its reactance, X_C , at the external voltage source frequency. Finally, compute the series resistor, capacitor peak voltage, and phase shift using the formulas shown below.

When this technique is used and the input signal is not present, the ZCD will tend to oscillate. To avoid this oscillation, connect the ZCD pin to V_{DD} or GND with a high-impedance resistor.

Note: In this example, the impedance value is calculated for a peak current of 300 μ A.

Equation 38-2. R-C Equations

V_{PEAK} = external voltage source peak voltage

f = external voltage source frequency

C = series capacitor

R = series resistor

V_C = peak capacitor voltage

Φ = capacitor induced zero-crossing phase advance in radians

T_Φ = time ZC event occurs before actual zero-crossing

$$Z = \frac{V_{PEAK}}{3 \times 10^{-4}}$$

$$X_C = \frac{1}{2\pi f C}$$

$$R = \sqrt{Z^2 - X_C^2}$$

$$V_C = X_C(3 \times 10^{-4})$$

$$\Phi = \tan^{-1}\left(\frac{X_C}{R}\right)$$

$$T_\Phi = \frac{\Phi}{2\pi f}$$

Equation 38-3. R-C Calculation Example

$$V_{rms} = 120$$

$$V_{PEAK} = V_{rms} \times \sqrt{2} = 169.7$$

$$f = 60 \text{ Hz}$$

$$C = 0.1 \mu\text{F}$$

$$Z = \frac{V_{PEAK}}{3 \times 10^{-4}} = \frac{169.7}{3 \times 10^{-4}} = 565.7 \text{ k}\Omega$$

$$X_C = \frac{1}{2\pi f C} = \frac{1}{2\pi \times 60 \times 10^{-7}} = 26.53 \text{ k}\Omega$$

$$R = \sqrt{Z^2 - X_C^2} = 565.1 \text{ k}\Omega \text{ (computed)}$$

$$R_a = 560 \text{ k}\Omega \text{ (used)}$$

$$Z_R = \sqrt{R_a^2 + X_C^2} = 560.6 \text{ k}\Omega$$

$$I_{PEAK} = \frac{V_{PEAK}}{Z_R} = 302.7 \times 10^{-6} \text{ A}$$

$$V_C = X_C \times I_{PEAK} = 8.0 \text{ V}$$

$$\Phi = \tan^{-1}\left(\frac{X_C}{R}\right) = 0.047 \text{ radians}$$

$$T_\Phi = \frac{\Phi}{2\pi f} = 125.6 \mu\text{s}$$

38.5.2 Correction by Offset Current

When the waveform is varying relative to V_{SS} , the zero-cross is detected too early as the waveform falls and too late as the waveform rises. When the waveform is varying relative to V_{DD} , the zero-cross is detected too late as the waveform rises and too early as the waveform falls. The actual offset time can be determined for sinusoidal waveforms with the corresponding equations shown below.

Equation 38-4. ZCD Event Offset

When External Voltage source is relative to V_{SS} :

$$T_{offset} = \frac{\sin^{-1}\left(\frac{Z_{CPINV}}{V_{PEAK}}\right)}{2\pi f}$$

When External Voltage source is relative to V_{DD} :

$$T_{offset} = \frac{\sin^{-1}\left(\frac{V_{DD} - Z_{CPINV}}{V_{PEAK}}\right)}{2\pi f}$$

This offset time can be compensated for by adding a pull-up or pull-down biasing resistor to the ZCD pin. A pull-up resistor is used when the external voltage source is varying relative to V_{SS} . A pull-down resistor is used when the voltage is varying relative to V_{DD} . The resistor adds a bias to the ZCD pin so that the target external voltage source must go to zero to pull the pin voltage to the Z_{CPINV} switching voltage. The pull-up or pull-down value can be determined with the equations shown below.

Equation 38-5. ZCD Pull-up/Pull-down Resistor

When External Voltage source is relative to V_{SS} :

$$R_{pullup} = \frac{R_{SERIES}(V_{pullup} - Z_{CPINV})}{Z_{CPINV}}$$

When External Voltage source is relative to V_{DD} :

$$R_{pulldown} = \frac{R_{SERIES}(Z_{CPINV})}{(V_{DD} - Z_{CPINV})}$$

38.6 Handling V_{PEAK} Variations

If the peak amplitude of the external voltage is expected to vary, the series resistor must be selected to keep the ZCD current source and to sink below the design maximum range specified by ZC02, and above a reasonable minimum range, depending on the application. The compensating pull-up for this series resistance can be determined with the equations shown in [Equation 38-5](#) because the pull-up value is independent from the peak voltage.



Tip: It is recommended that the maximum peak voltage be no more than six times the minimum peak voltage.

38.7 Operation During Sleep

The ZCD current sources and interrupts are unaffected by Sleep.

38.8 Effects of a Reset

The ZCD circuit can be configured to default to the Active or Inactive state on Power-on Reset (POR). When the \overline{ZCD} Configuration bit is cleared, the ZCD circuit will be active at POR. When the \overline{ZCD} Configuration bit is set, the [SEN](#) bit must be set to enable the ZCD module.

38.9 Disabling the ZCD Module

The ZCD module can be disabled in two ways:

1. The \overline{ZCD} Configuration bit disables the ZCD module when set. When this is the case, then the ZCD module will be enabled by setting the [SEN](#) bit. When the \overline{ZCD} bit is clear, the ZCD is always enabled and the [SEN](#) bit has no effect.
2. The ZCD can also be disabled using the ZCDMD bit of the PMDx register. This is subject to the status of the \overline{ZCD} bit.

38.10 Register Definitions: ZCD Control

Long bit name prefixes for the ZCD peripherals are shown in the table below. Refer to the “**Long Bit Names**” section of the “**Register and Bit Naming Conventions**” chapter for more information.

Table 38-1. ZCD Long Bit Name Prefixes

Peripheral	Bit Name Prefix
ZCD	ZCD

38.10.1 ZCDCON

Name: ZCDCON
Offset: 0x021F

Zero-Cross Detect Control Register

Bit	7	6	5	4	3	2	1	0
	SEN		OUT	POL			INTP	INTN
Access	R/W		R	R/W			R/W	R/W
Reset	0		x	0			0	0

Bit 7 – SEN Zero-Cross Detect Software Enable

This bit is ignored when the ZCD fuse is cleared.

Value	Condition	Description
x	ZCD Config fuse = 0	Zero-cross detect is always enabled. This bit is ignored.
1	ZCD Config fuse = 1	Zero-cross detect is enabled. ZCD pin is forced to output to source and sink current.
0	ZCD Config fuse = 1	Zero-cross detect is disabled. ZCD pin operates according to PPS and TRIS controls.

Bit 5 – OUT Zero-Cross Detect Data Output

Value	Condition	Description
1	POL = 0	ZCD pin is sinking current
0	POL = 0	ZCD pin is sourcing current
1	POL = 1	ZCD pin is sourcing current
0	POL = 1	ZCD pin is sinking current

Bit 4 – POL Zero-Cross Detect Polarity

Value	Description
1	ZCD logic output is inverted
0	ZCD logic output is not inverted

Bit 1 – INTP Zero-Cross Detect Positive-Going Edge Interrupt Enable

Value	Description
1	The ZCDIF bit is set on low-to-high ZCD_output transition
0	The ZCDIF bit is unaffected by low-to-high ZCD_output transition

Bit 0 – INTN Zero-Cross Detect Negative-Going Edge Interrupt Enable

Value	Description
1	The ZCDIF bit is set on high-to-low ZCD_output transition
0	The ZCDIF bit is unaffected by high-to-low ZCD_output transition

38.11 Register Summary - ZCD

Offset	Name	Bit Pos.	7	6	5	4	3	2	1	0
0x00	Reserved									
...										
0x021E										
0x021F	ZCDCON	7:0	SEN		OUT	POL			INTP	INTN

39. Charge Pump

This family of devices offers a dedicated charge pump, which is controlled through the Charge Pump Control (CPON) register. The primary purpose of the charge pump is to supply a constant voltage to the gates of transistor devices contained in analog peripherals, signal and reference input pass-gates, and to prevent degradation of transistor performance at low operating voltages.

The charge pump offers the following modes:

- Manually Enabled
- Automatically Enabled
- Disabled

39.1 Manually Enabled

The charge pump can be manually enabled via the Charge Pump Enable (CPON) bits. When the CPON bits are configured as '11', the charge pump is enabled. In this case, the charge pump provides additional voltage to all analog systems, regardless of V_{DD} levels, but also consumes additional current.

39.2 Automatically Enabled

The charge pump can also be enabled automatically. This allows the application to determine when to enable the charge pump. If the charge pump is enabled while V_{DD} levels are above a sufficient threshold, the charge pump does not improve analog performance, but also consumes additional current. Allowing hardware to monitor V_{DD} and determine when to enable the charge pump prevents unnecessary current consumption.

When the CPON bits are configured as '10', charge pump hardware monitors V_{DD} and compares the V_{DD} levels to a reference voltage threshold (V_{AUTO}), which is set to 4.6V. When hardware detects a V_{DD} level lower than the threshold, the charge pump is automatically enabled. If V_{DD} returns to a level above the threshold, hardware automatically disables the charge pump.

When the CPON bits are configured as '01', charge pump hardware waits for an analog peripheral, such as the ADC, to be enabled before monitoring V_{DD} . In this case, charge pump hardware monitors all analog peripherals, and once an analog peripheral is enabled, hardware begins to compare V_{DD} to V_{AUTO} . When hardware detects a V_{DD} level lower than the threshold, hardware enables the charge pump. If V_{DD} returns to a level above the threshold, or if the analog peripheral is disabled, the charge pump is automatically disabled.

39.3 Disabled

The charge pump is disabled by default (CPON = 00). Clearing the CPON bits will disable the charge pump.

39.4 Charge Pump Oscillator

The Charge Pump Oscillator Selection (CPOS) bit selects the charge pump oscillator source. The CPOS bit allows the user to select between the charge pump's internal oscillator or the oscillator driving the ADC.

When CPOS is set (CPOS = 1), the charge pump utilizes its internal oscillator. The charge pump's internal oscillator provides a very steady output voltage, but at the expense of higher operating current.

When CPOS is clear (CPOS = 0) and the ADGO bit is clear (GO = 0), the charge pump is clocked by the ADCRC. When ADGO is set (GO = 1), the charge pump is clocked by a derivative of the F_{OSC} (as determined by the ADCLK register). This allows the charge pump to operate at a lower current when the ADC is not converting, while offering higher performance when the ADC is converting.

39.5 Charge Pump Threshold

The Charge Pump Threshold (CPT) bit indicates whether or not V_{DD} is at an acceptable operating level. Charge pump hardware compares V_{DD} to the threshold voltage (V_{AUTO}), which is set at 4.6V. If V_{DD} is above V_{AUTO} , the CPT bit is set (CPT = 1). If V_{DD} is below V_{AUTO} , CPT is clear (CPT = 0).

39.6 Charge Pump Ready

The Charge Pump Ready Status (CPRDY) bit indicates whether or not the charge pump is ready for use. When CPRDY is set (CPRDY = 1), the charge pump has reached a steady-state operation and is ready for use. When CPRDY is clear (CPRDY = 0), the charge pump is either in the OFF state or has not reached a steady-state operation.

39.7 Register Definitions: Charge Pump

39.7.1 CPCON**Name:** CPCON**Offset:** 0x020D

Charge Pump Control Register

Bit	7	6	5	4	3	2	1	0
	CPON[1:0]		CPOS			CPREQ	CPT	CPRDY
Access	R/W	R/W	R/W			R	R	R
Reset	0	0	0			0	0	0

Bits 7:6 – CPON[1:0]

Charge Pump Enable

Value	Description
11	Charge pump is enabled
10	Charge pump is automatically enabled when $V_{DD} < V_{AUTO}$ ($V_{AUTO} = 4.6V$)
01	Charge pump is automatically enabled when an analog peripheral is enabled ($ADCON0.ON = 1$) and $V_{DD} < V_{AUTO}$
00	Charge pump is disabled

Bit 5 – CPOS

Charge Pump Oscillator Selection

Value	Condition	Description
1		Charge pump clock is the internal charge pump oscillator
0	When ADC GO bit = 1	Charge pump clock is FOSC (oscillator frequency determined by ADCLK)
0	When ADC GO bit = 0	Charge pump clock is the ADCRC

Bit 2 – CPREQ

Charge Pump Request Status

Value	Description
1	Charge pump has been requested by an analog peripheral
0	Charge pump has not been requested by an analog peripheral

Bit 1 – CPT

Charge Pump Threshold

Value	Description
1	V_{DD} is above the charge pump auto-enable threshold (V_{AUTO})
0	V_{DD} is below the charge pump auto-enable threshold (V_{AUTO})

Bit 0 – CPRDY

Charge Pump Ready Status

Value	Description
1	Charge pump has reached a steady-state operation
0	Charge pump is off or has not reached a steady-state operation

39.8 Register Summary - Charge Pump

Offset	Name	Bit Pos.	7	6	5	4	3	2	1	0
0x00	Reserved									
...										
0x020C										
0x020D	CPCON	7:0	CPON[1:0]		CPOS			CPREQ	CPT	CPRDY

40. Instruction Set Summary

The PIC16F181 devices incorporate the standard set of 50 PIC16 core instructions. Each instruction is a 14-bit word containing the operation code (opcode) and all required operands. The opcodes are broken into three broad categories:

- Byte-Oriented
- Bit-Oriented
- Literal and Control

The literal and control category contains the most varied instruction word format.

[Table 40-3](#) lists the instructions recognized by the XC8 assembler.

All instructions are executed within a single instruction cycle, with the following exceptions, which may take two or three cycles:

- Subroutine entry takes two cycles (*CALL*, *CALLW*)
- Returns from interrupts or subroutines take two cycles (*RETURN*, *RETLW*, *RETFIE*)
- Program branching takes two cycles (*GOTO*, *BRA*, *BRW*, *BTFSS*, *BTFSC*, *DECFSZ*, *INCSFZ*)
- One additional instruction cycle will be used when any instruction references an indirect file register and when the file select register is pointing to program memory

One instruction cycle consists of four oscillator cycles; for an oscillator frequency of 4 MHz, this gives a nominal instruction execution rate of 1 MHz.

All instruction examples use the format '0xhh' to represent a hexadecimal number, where 'h' signifies a hexadecimal digit.

40.1 Read-Modify-Write Operations

Any instruction that specifies a file register as part of the instruction performs a Read-Modify-Write (RMW) operation. The register is read, the data are modified, and the result is stored according to either the Working (W) register or the originating file register, depending on the state of the destination designator 'd' (see [Table 40-1](#) for more information). A read operation is performed on a register even if the instruction writes to that register.

Table 40-1. Opcode Field Descriptions

Field	Description
f	Register file address (0x00 to 0x7F)
W	Working register (accumulator)
b	Bit address within an 8-bit file register
k	Literal field, constant data or label
x	"Don't care" location (= 0 or 1). The assembler will generate code with x = 0. It is the recommended form of use for compatibility with all Microchip software tools.
d	Destination select; d = 0: store result in W, d = 1: store result in file register f.
n	FSR or INDF number. (0-1)
mm	Pre/post increment/decrement mode selection

Table 40-2. Abbreviation Descriptions

Field	Description
PC	Program Counter
TO	Time-Out bit
C	Carry bit

.....continued	
Field	Description
DC	Digit Carry bit
Z	Zero bit
PD	Power-Down bit

40.2 Standard Instruction Set

Table 40-3. Instruction Set

Mnemonic, Operands	Description	Cycles	14-Bit Opcode				Status Affected	Notes	
			MSb			LSb			
BYTE-ORIENTED OPERATIONS									
ADDWF	f, d	Add WREG and f	1	00	0111	dfff	ffff	C, DC, Z	2
ADDWFC	f, d	Add WREG and Carry bit to f	1	11	1101	dfff	ffff	C, DC, Z	2
ANDWF	f, d	AND WREG with f	1	00	0101	dfff	ffff	Z	2
ASRF	f, d	Arithmetic Right Shift	1	11	0111	dfff	ffff	C, Z	2
LSLF	f, d	Logical Left Shift	1	11	0101	dfff	ffff	C, Z	2
LSRF	f, d	Logical Right Shift	1	11	0110	dfff	ffff	C, Z	2
CLRF	f	Clear f	1	00	0001	1fff	ffff	Z	2
CLRW	-	Clear WREG	1	00	0001	0000	00xx	Z	
COMF	f, d	Complement f	1	00	1001	dfff	ffff	Z	2
DECf	f, d	Decrement f	1	00	0011	dfff	ffff	Z	2
INCF	f, d	Increment f	1	00	1010	dfff	ffff	Z	2
IORWF	f, d	Inclusive OR WREG with f	1	00	0100	dfff	ffff	Z	2
MOVF	f, d	Move f	1	00	1000	dfff	ffff	Z	2
MOVWF	f	Move WREG to f	1	00	0000	1fff	ffff	None	2
RLF	f, d	Rotate Left f through Carry	1	00	1101	dfff	ffff	C	2
RRF	f, d	Rotate Right f through Carry	1	00	1100	dfff	ffff	C	2
SUBWF	f, d	Subtract WREG from f	1	00	0010	dfff	ffff	C, DC, Z	2
SUBWFB	f, d	Subtract WREG from f with Borrow	1	11	1011	dfff	ffff	C, DC, Z	2
SWAPF	f, d	Swap nibbles in f	1	00	1110	dfff	ffff	None	2

.....continued

Mnemonic, Operands	Description	Cycles	14-Bit Opcode				Status Affected	Notes	
			MSb			LSb			
XORWF	f, d	Exclusive OR WREG with f	1	00	0110	dfff	ffff	Z	2
BYTE-ORIENTED SKIP OPERATIONS									
DECFSZ	f, d	Decrement f, Skip if 0	1(2)	00	1011	dfff	ffff	None	1, 2
INCFSZ	f, d	Increment f, Skip if 0	1(2)	00	1111	dfff	ffff	None	1, 2
BIT-ORIENTED FILE REGISTER OPERATIONS									
BCF	f, b	Bit Clear f	1	01	00bb	bfff	ffff	None	2
BSF	f, b	Bit Set f	1	01	01bb	bfff	ffff	None	2
BIT-ORIENTED SKIP OPERATIONS									
BTFSC	f, b	Bit Test f, Skip if Clear	1(2)	01	10bb	bfff	ffff	None	1, 2
BTFSS	f, b	Bit Test f, Skip if Set	1(2)	1010	11bb	bfff	ffff	None	1, 2
LITERAL OPERATIONS									
ADDLW	k	Add literal and WREG	1	11	1110	kkkk	kkkk	C, DC, Z	
ANDLW	k	AND literal with WREG	1	11	1001	kkkk	kkkk	Z	
IORLW	k	Inclusive OR literal with WREG	1	11	1000	kkkk	kkkk	Z	
MOVLB	k	Move literal to BSR	1	00	000	0k	kkkk	None	
MOVLP	k	Move literal to PCLATH	1	11	0001	1kkk	kkkk	None	
MOVLW	k	Move literal to W	1	11	0000	kkkk	kkkk	None	
SUBLW	k	Subtract W from literal	1	11	1100	kkkk	kkkk	C, DC, Z	
XORLW	k	Exclusive OR literal with W	1	11	1010	kkkk	kkkk	Z	
CONTROL OPERATIONS									

.....continued

Mnemonic, Operands		Description	Cycles	14-Bit Opcode				Status Affected	Notes
				MSb			LSb		
BRA	k	Relative Branch	2	11	001k	kkkk	kkkk	None	
BRW	—	Relative Branch with WREG	2	00	0000	0000	1011	None	
CALL	k	Call Subroutine	2	10	0kkk	kkkk	kkkk	None	
CALLW	—	Call Subroutine with WREG	2	00	0000	0000	1010	None	
GOTO	k	Go to address	2	10	1kkk	kkkk	kkkk	None	
RETFIE	k	Return from interrupt	2	00	0000	0000	1001	None	
RETLW	k	Return with literal in WREG	2	11	0100	kkkk	kkkk	None	
RETURN	—	Return from Subroutine	2	00	0000	0000	1000	None	
INHERENT OPERATIONS									
CLRWDT	—	Clear Watchdog Timer	1	00	0000	0110	0100	\overline{TO} , \overline{PD}	
NOP	—	No Operation	1	00	0000	0000	0000	None	
RESET	—	Software device Reset	1	00	0000	0000	0001	None	
SLEEP	—	Go into Standby mode	1	00	0000	0110	0011	\overline{TO} , \overline{PD}	
TRIS	f	Load TRIS register with WREG	1	00	0000	0110	0fff	None	
C-COMPILER OPTIMIZED									
ADDFSR	n, k	Add Literal k to FSRn	1	11	0001	0nkk	kkkk	None	
MOVIW	n, mm	Move Indirect FSRn to WREG with pre/post inc/dec modifier, mm	1	00	0000	0001	0nmm	Z	2, 3
	k[n]	Move INDFn to WREG, Indexed Indirect.	1	11	1111	0nkk	kkkk	Z	2
MOVWI	n, mm	Move WREG to Indirect FSRn with pre/post inc/dec modifier, mm	1	00	0000	0001	1nmm	None	2, 3
	k[n]	Move WREG to INDFn, Indexed Indirect.	1	11	1111	1nkk	kkkk	None	2

Notes:

1. If the Program Counter (PC) is modified or a conditional test is true, the instruction requires two cycles. The second cycle is executed as a NOP.
2. If this instruction addresses an INDF register and the MSb of the corresponding FSR is set, this instruction will require one additional instruction cycle.
3. Details on MOVIW and MOVWI instruction descriptions are available in the next section.

40.2.1 Standard Instruction Set

ADDFSR	Add Literal to FSRn
Syntax:	[<i>label</i>] ADDFSR FSRn, k
Operands:	$-32 \leq k \leq 31$; $n \in [0, 1]$
Operation:	$FSR(n) + k \rightarrow FSR(n)$
Status Affected:	None
Description:	The signed 6-bit literal 'k' is added to the contents of the FSRnH:FSRnL register pair. FSRn is limited to the range 0000h-FFFFh. Moving beyond these bounds will cause the FSR to wrap-around.

ADDLW	Add Literal to W
Syntax:	[<i>label</i>] ADDLW k
Operands:	$0 \leq k \leq 255$
Operation:	$(W) + k \rightarrow (W)$
Status Affected:	C, DC, Z
Description:	The contents of W are added to the 8-bit literal 'k' and the result is placed in W.

ADDWF	Add W to f
Syntax:	[<i>label</i>] ADDWF f, d
Operands:	$0 \leq f \leq 127$ $d \in [0,1]$
Operation:	$(W) + (f) \rightarrow \text{dest}$
Status Affected:	C, DC, Z
Description:	Add the contents of the W register with register 'f'. If 'd' is '0', the result is stored in the W register. If 'd' is '1', the result is stored back in register 'f'.

ADDWFC	Add W and Carry Bit to f
Syntax:	[<i>label</i>] ADDWFC f {,d}
Operands:	$0 \leq f \leq 127$ $d \in [0,1]$
Operation:	$(W) + (f) + (C) \rightarrow \text{dest}$
Status Affected:	C, DC, Z
Description:	Add W, the Carry flag and data memory location 'f'. If 'd' is '0', the result is placed in W. If 'd' is '1', the result is placed in data memory location 'f'.

ANDLW	AND Literal with W
Syntax:	[<i>label</i>] ANDLW k
Operands:	$0 \leq k \leq 255$
Operation:	$(W) .\text{AND. } k \rightarrow (W)$
Status Affected:	Z
Description:	The contents of W are AND'ed with the 8-bit literal 'k'. The result is placed in W.

ANDWF	AND W with f
Syntax:	[<i>label</i>] ANDWF f, d
Operands:	$0 \leq f \leq 127$ $d \in [0,1]$
Operation:	$(W) .\text{AND. } (f) \rightarrow \text{dest}$

.....continued

ANDWF	AND W with f
Status Affected:	Z
Description:	AND the W register with register 'f'. If 'd' is '0', the result is stored in the W register. If 'd' is '1', the result is stored back in register 'f'.

ASRF	Arithmetic Right Shift
Syntax:	[label] ASRF f, d
Operands:	$0 \leq f \leq 127$ $d \in [0,1]$
Operation:	$(f[7]) \rightarrow \text{dest}[7]$ $(f[7:1]) \rightarrow \text{dest}[6:0]$ $(f[0]) \rightarrow C$
Status Affected:	C, Z
Description:	The contents of register 'f' are shifted one bit to the right through the Carry flag. The MSb remains unchanged. If 'd' is '0', the result is placed in W. If 'd' is '1', the result is stored back in register 'f'. Register f → C

BCF	Bit Clear f
Syntax:	[label] BCF f, b
Operands:	$0 \leq f \leq 127$ $0 \leq b \leq 7$
Operation:	$0 \rightarrow f[b]$
Status Affected:	None
Description:	Bit 'b' in register 'f' is cleared.

BRA	Relative Branch
Syntax:	[label] BRA label [label] BRA \$+k
Operands:	$-256 \leq \text{label} - \text{PC} + 1 \leq 255$ $-256 \leq k \leq 255$
Operation:	$(\text{PC}) + 1 + k \rightarrow \text{PC}$
Status Affected:	None
Description:	Add the signed 9-bit literal 'k' to the PC. Since the PC will have incremented to fetch the next instruction, the new address will be $\text{PC} + 1 + k$. This instruction is a two-cycle instruction. This branch has a limited range.

BRW	Relative Branch with W
Syntax:	[label] BRW
Operands:	None
Operation:	$(\text{PC}) + (\text{W}) \rightarrow \text{PC}$
Status Affected:	None
Description:	Add the contents of W (unsigned) to the PC. Since the PC will have incremented to fetch the next instruction, the new address will be $\text{PC} + 1 + (\text{W})$. This instruction is a two-cycle instruction.

BSF	Bit Set f
Syntax:	[label] BSF f, b
Operands:	$0 \leq f \leq 127$ $0 \leq b \leq 7$

.....continued

BSF	Bit Set f
Operation:	1 → (f[b])
Status Affected:	None
Description:	Bit 'b' in register 'f' is set.

BTFSC	Bit Test File, Skip If Clear
Syntax:	[label] BTFSC f, b
Operands:	0 ≤ f ≤ 127 0 ≤ b ≤ 7
Operation:	skip if (f[b]) = 0
Status Affected:	None
Description:	If bit 'b' in register 'f' is '1', the next instruction is executed. If bit 'b', in register 'f', is '0', the next instruction is discarded, and a NOP is executed instead, making this a two-cycle instruction.

BTFSS	Bit Test File, Skip If Set
Syntax:	[label] BTFSS f, b
Operands:	0 ≤ f ≤ 127 0 ≤ b < 7
Operation:	skip if (f[b]) = 1
Status Affected:	None
Description:	If bit 'b' in register 'f' is '0', the next instruction is executed. If bit 'b' is '1', then the next instruction is discarded, and a NOP is executed instead, making this a two-cycle instruction.

CALL	Subroutine Call
Syntax:	[label] CALL k
Operands:	0 ≤ k ≤ 2047
Operation:	(PC) + 1 → TOS, k → PC[10:0], (PCLATH[6:3]) → PC[14:11]
Status Affected:	None
Description:	Call Subroutine. First, return address (PC + 1) is pushed onto the stack. The 11-bit immediate address is loaded into PC bits [10:0]. The upper bits of the PC are loaded from PCLATH. CALL is a two-cycle instruction.

CALLW	Subroutine Call with W
Syntax:	[label] CALLW
Operands:	None
Operation:	(PC) + 1 → TOS, (W) → PC[7:0], (PCLATH[6:0]) → PC[14:8]
Status Affected:	None
Description:	Subroutine call with W. First, the return address (PC + 1) is pushed onto the return stack. Then, the contents of W is loaded into PC[7:0], and the contents of PCLATH into PC[14:8]. CALLW is a two-cycle instruction.

CLRF	Clear f
Syntax:	[label] CLRF f

.....continued

CLRF	Clear f
Operands:	$0 \leq f \leq 127$
Operation:	000h \rightarrow f 1 \rightarrow Z
Status Affected:	Z
Description:	The contents of register 'f' are cleared and the Z bit is set.

CLRW	Clear W
Syntax:	[<i>label</i>] CLRW
Operands:	None
Operation:	00h \rightarrow (W) 1 \rightarrow Z
Status Affected:	Z
Description:	W register is cleared. Zero (Z) bit is set.

CLRWDT	Clear Watchdog Timer
Syntax:	[<i>label</i>] CLRWDT
Operands:	None
Operation:	00h \rightarrow WDT, 00h \rightarrow WDT prescaler, 1 \rightarrow \overline{TO} , 1 \rightarrow \overline{PD}
Status Affected:	\overline{TO} , \overline{PD}
Description:	The CLRWDT instruction resets the Watchdog Timer. It also resets the prescaler of the WDT. Status bits, \overline{TO} and \overline{PD} , are set.

COMF	Complement f
Syntax:	[<i>label</i>] COMF f, d
Operands:	$0 \leq f \leq 127$ $d \in [0,1]$
Operation:	(f) \rightarrow dest
Status Affected:	Z
Description:	The contents of register 'f' are complemented. If 'd' is '0', the result is stored in W. If 'd' is '1', the result is stored back in register 'f'.

DECF	Decrement f
Syntax:	[<i>label</i>] DECF f, d
Operands:	$0 \leq f \leq 127$ $d \in [0,1]$
Operation:	(f) - 1 \rightarrow dest
Status Affected:	Z
Description:	Decrement register 'f'. If 'd' is '0', the result is stored in the W register. If 'd' is '1', the result is stored back in register 'f'.

DECFSZ	Decrement f, Skip If 0
Syntax:	[<i>label</i>] DECFSZ f, d

.....continued

DECFSZ	Decrement f, Skip If 0
Operands:	$0 \leq f \leq 127$ $d \in [0,1]$
Operation:	$(f) - 1 \rightarrow \text{dest}$, skip if result = 0
Description:	The contents of register 'f' are decremented. If 'd' is '0', the result is placed in the W register. If 'd' is '1', the result is placed back in register 'f'. If the result is '1', the next instruction is executed. If the result is '0', then a NOP is executed instead, making it a two-cycle instruction.

GOTO	Unconditional Branch
Syntax:	[label] GOTO k
Operands:	$0 \leq k \leq 2047$
Operation:	$k \rightarrow \text{PC}[10:0]$ $\text{PCLATH}[6:3] \rightarrow \text{PC}[14:11]$
Status Affected:	None
Description:	GOTO is an unconditional branch. The 11-bit immediate value is loaded into PC bits [10:0]. The upper bits of PC are loaded from PCLATH[4:3]. GOTO is a two-cycle instruction.

INCF	Increment f
Syntax:	[label] INCF f, d
Operands:	$0 \leq f \leq 127$ $d \in [0,1]$
Operation:	$(f) + 1 \rightarrow \text{dest}$
Status Affected:	Z
Description:	The contents of register 'f' are incremented. If 'd' is '0', the result is placed in the W register. If 'd' is '1', the result is placed back in register 'f'.

INCFSZ	Increment f, Skip If 0
Syntax:	[label] INCFSZ f, d
Operands:	$0 \leq f \leq 127$ $d \in [0,1]$
Operation:	$(f) + 1 \rightarrow \text{dest}$, skip if result = 0
Status Affected:	None
Description:	The contents of register 'f' are incremented. If 'd' is '0', the result is placed in the W register. If 'd' is '1', the result is placed back in register 'f'. If the result is '1', the next instruction is executed. If the result is '0', a NOP is executed instead, making it a two-cycle instruction.

IORLW	Inclusive OR Literal with W
Syntax:	[label] IORLW k
Operands:	$0 \leq k \leq 255$
Operation:	$(W) .OR. k \rightarrow (W)$
Status Affected:	Z

.....continued

IORLW	Inclusive OR Literal with W
Description:	The contents of W are ORed with the 8-bit literal 'k'. The result is placed in W.

IORWF	Inclusive OR W with f
Syntax:	IORWF f, d
Operands:	$0 \leq f \leq 127$ $d \in [0,1]$
Operation:	(W) .OR. (f) \rightarrow dest
Status Affected:	Z
Description:	Inclusive OR the W register with register 'f'. If 'd' is '0', the result is placed in the W register. If 'd' is '1', the result is placed back in register 'f'.

LSLF	Logical Left Shift
Syntax:	[label] LSLF f {,d}
Operands:	$0 \leq f \leq 127$ $d \in [0,1]$
Operation:	(f[7]) \rightarrow C (f[6:0]) \rightarrow dest[7:1] $0 \rightarrow$ dest[0]
Status Affected:	C, Z
Description:	The contents of register 'f' are shifted one bit to the left through the Carry flag. A '0' is shifted into the LSB. If 'd' is '0', the result is placed in W. If 'd' is '1', the result is stored back in register 'f'. C \leftarrow Register f \leftarrow 0

LSRF	Logical Right Shift
Syntax:	[label] LSRF f {,d}
Operands:	$0 \leq f \leq 127$ $d \in [0,1]$
Operation:	$0 \rightarrow$ dest[7] (f[7:1]) \rightarrow dest[6:0], (f[0]) \rightarrow C
Status Affected:	C, Z
Description:	The contents of register 'f' are shifted one bit to the right through the Carry flag. A '0' is shifted into the MSb. If 'd' is '0', the result is placed in W. If 'd' is '1', the result is stored back in register 'f'. 0 \rightarrow Register f \rightarrow C

MOVF	Move f
Syntax:	[label] MOVF f, d
Operands:	$0 \leq f \leq 127$ $d \in [0,1]$
Operation:	f \rightarrow dest
Status Affected:	Z
Description:	The contents of register f is moved to a destination dependent upon the status of d. If d = 0, destination is W register. If d = 1, the destination is file register f itself. d = 1 is useful to test a file register since status flag Z is affected.

.....continued

MOVF	Move f
Words:	1
Cycles:	1

Example:	<code>MOVF FSR, 0</code>
After Instruction W = value in FSR register Z = 1	

MOVIW	Move INDFn to W																				
Syntax:	[<i>label</i>] MOVIW ++FSRn [<i>label</i>] MOVIW --FSRn [<i>label</i>] MOVIW FSRn++ [<i>label</i>] MOVIW FSRn-- [<i>label</i>] MOVIW k[FSRn]																				
Operands:	$n \in [0,1]$ $mm \in [00,01,10,11]$ $-32 \leq k \leq 31$																				
Operation:	INDFn \rightarrow (W) Effective address is determined by <ul style="list-style-type: none"> FSR + 1 (preincrement) FSR - 1 (predecrement) FSR + k (relative offset) After the Move, the FSR value will be either: <ul style="list-style-type: none"> FSR + 1 (all increments) FSR - 1 (all decrements) Unchanged 																				
Status Affected:	Z <table border="1"> <thead> <tr> <th></th> <th>MODE</th> <th>SYNTAX</th> <th>mm</th> </tr> </thead> <tbody> <tr> <td>Preincrement</td> <td></td> <td>++FSRn</td> <td>00</td> </tr> <tr> <td>Predecrement</td> <td></td> <td>--FSRn</td> <td>01</td> </tr> <tr> <td>Postincrement</td> <td></td> <td>FSRn++</td> <td>10</td> </tr> <tr> <td>Postdecrement</td> <td></td> <td>FSRn--</td> <td>11</td> </tr> </tbody> </table>		MODE	SYNTAX	mm	Preincrement		++FSRn	00	Predecrement		--FSRn	01	Postincrement		FSRn++	10	Postdecrement		FSRn--	11
	MODE	SYNTAX	mm																		
Preincrement		++FSRn	00																		
Predecrement		--FSRn	01																		
Postincrement		FSRn++	10																		
Postdecrement		FSRn--	11																		
Description:	This instruction is used to move data between W and one of the indirect registers (INDFn). Before/after this move, the pointer (FSRn) is updated by pre/post incrementing/decrementing it. The INDFn registers are not physical registers. Any instruction that accesses an INDFn register actually accesses the register at the address specified by the FSRn. FSRn is limited to the range 0000h - FFFFh. Incrementing/decrementing it beyond these bounds will cause it to wrap-around.																				

MOVLB	Move Literal to BSR
Syntax:	[<i>label</i>] MOVLB k
Operands:	$0 \leq k \leq 127$
Operation:	$k \rightarrow \text{BSR}$
Status Affected:	None
Description:	The 6-bit literal 'k' is loaded into the Bank Select Register (BSR).

MOVLP	Move Literal to PCLATH
Syntax:	[<i>label</i>] MOVLP k
Operands:	$0 \leq k \leq 127$
Operation:	$k \rightarrow \text{PCLATH}$
Status Affected:	None
Description:	The 7-bit literal 'k' is loaded into the PCLATH register.

MOVLW	Move Literal to W
Syntax:	[<i>label</i>] MOVLW k
Operands:	$0 \leq k \leq 255$
Operation:	$k \rightarrow (W)$
Status Affected:	None
Description:	The 8-bit literal 'k' is loaded into W register. The "don't cares" will assemble as '0's.
Words:	1
Cycles:	1

Example:	MOVLW	5Ah
After Instruction W = 5Ah		

MOVWF	Move W to f
Syntax:	[<i>label</i>] MOVWF f
Operands:	$0 \leq f \leq 127$
Operation:	$(W) \rightarrow f$
Status Affected:	None
Description:	Move data from W to register 'f'.
Words:	1
Cycles:	1

Example:	MOVWF	LATA
Before Instruction LATA = FFh W = 4Fh After Instruction LATA = 4Fh W = 4Fh		

MOVWI	Move W to INDFn
Syntax:	[<i>label</i>] MOVWI ++FSRn [<i>label</i>] MOVWI --FSRn [<i>label</i>] MOVWI FSRn++ [<i>label</i>] MOVWI FSRn-- [<i>label</i>] MOVWI k[FSRn]
Operands:	$n \in [0,1]$ $mm \in [00,01,10,11]$ $-32 \leq k \leq 31$

.....continued

MOVWI	Move W to INDFn															
Operation:	<p>(W) → INDFn</p> <p>Effective address is determined by</p> <ul style="list-style-type: none"> FSR + 1 (preincrement) FSR - 1 (predecrement) FSR + k (relative offset) <p>After the Move, the FSR value will be either:</p> <ul style="list-style-type: none"> FSR + 1 (all increments) FSR - 1 (all decrements) Unchanged 															
Status Affected:	None															
	<table border="1"> <thead> <tr> <th>MODE</th> <th>SYNTAX</th> <th>mm</th> </tr> </thead> <tbody> <tr> <td>Preincrement</td> <td>++FSRn</td> <td>00</td> </tr> <tr> <td>Predecrement</td> <td>--FSRn</td> <td>01</td> </tr> <tr> <td>Postincrement</td> <td>FSRn++</td> <td>10</td> </tr> <tr> <td>Postdecrement</td> <td>FSRn--</td> <td>11</td> </tr> </tbody> </table>	MODE	SYNTAX	mm	Preincrement	++FSRn	00	Predecrement	--FSRn	01	Postincrement	FSRn++	10	Postdecrement	FSRn--	11
	MODE	SYNTAX	mm													
	Preincrement	++FSRn	00													
	Predecrement	--FSRn	01													
Postincrement	FSRn++	10														
Postdecrement	FSRn--	11														
Description:	<p>This instruction is used to move data between W and one of the indirect registers (INDFn). Before/after this move, the pointer (FSRn) is updated by pre/post incrementing/decrementing it. The INDFn registers are not physical registers.</p> <p>Any instruction that accesses an INDFn register actually accesses the register at the address specified by the FSRn.</p> <p>FSRn is limited to the range 0000h-FFFFh.</p> <p>Incrementing/decrementing it beyond these bounds will cause it to wrap-around.</p> <p>The increment/decrement operation on FSRn will not affect any Status bits.</p>															

NOP	No Operation
Syntax:	[label] NOP
Operands:	None
Operation:	No operation
Status Affected:	None
Description:	No operation.
Words:	1
Cycles:	1

Example:	NOP
None.	

RESET	Software Reset
Syntax:	[label] RESET
Operands:	None
Operation:	Execute a device Reset. Resets the $\bar{R}I$ flag of the PCON register.
Status Affected:	None
Description:	This instruction provides a way to execute a hardware Reset by software.

RETFIE	Return from Interrupt
Syntax:	[label] RETFIE k
Operands:	None

.....continued

RETFIE	Return from Interrupt			
Operation:	(TOS) → PC, 1 → GIE			
Status Affected:	None			
Description:	Return from Interrupt. Stack is POPed and Top-of-Stack (TOS) is loaded in the PC. Interrupts are enabled by setting the Global Interrupt Enable bit, GIE (INTCON[7]). This is a two-cycle instruction.			
Words:	1			
Cycles:	2			

Example:	RETFIE
After Interrupt PC = TOS GIE = 1	

RETLW	Return Literal to W			
Syntax:	[label] RETLW k			
Operands:	0 ≤ k ≤ 255			
Operation:	k → (W), (TOS) → PC,			
Status Affected:	None			
Description:	The W register is loaded with the 8-bit literal 'k'. The program counter is loaded from the top of the stack (the return address). This is a two-cycle instruction.			
Words:	1			
Cycles:	2			

Example:	<pre> CALL TABLE ; W contains table ; offset value ; W now has ; table value : TABLE ADDWF PC ; W = offset RETLW k1 ; Begin table RETLW k2 ; : : RETLW kn ; End of table </pre>			
Before Instruction W = 07h After Instruction W = value of k8				

RETURN	Return from Subroutine			
Syntax:	[label] RETURN			
Operands:	None			
Operation:	(TOS) → PC,			
Status Affected:	None			
Encoding:	0000	0000	0001	001s

.....continued

RETURN	Return from Subroutine
Description:	Return from subroutine. The stack is POPped and the top of the stack (TOS) is loaded into the Program Counter. This is a two-cycle instruction.

RLF	Rotate Left f through Carry
Syntax:	[<i>label</i>] RLF f, d
Operands:	$0 \leq f \leq 127$ $d \in [0,1]$
Operation:	$(f[n]) \rightarrow \text{dest}[n + 1]$, $(f[7]) \rightarrow C$, $(C) \rightarrow \text{dest}[0]$
Status Affected:	C
Encoding:	0011 01da ffff ffff
Description:	The contents of register 'f' are rotated one bit to the left through the Carry flag. If 'd' is '0', the result is placed in W. If 'd' is '1', the result is stored back in register 'f' (default). <div style="text-align: center;"> </div>
Words:	1
Cycles:	1

Example:	RLF	REG1, 0
Before Instruction REG1 = 1110 0110 C = 0		
After Instruction REG = 1110 0110 W = 1100 1100 C = 1		

RRF	Rotate Right f through Carry
Syntax:	[<i>label</i>] RRF f, d
Operands:	$0 \leq f \leq 127$ $d \in [0,1]$
Operation:	$(f[n]) \rightarrow \text{dest}[n - 1]$, $(f[0]) \rightarrow C$, $(C) \rightarrow \text{dest}[7]$
Status Affected:	C
Description:	The contents of register 'f' are rotated one bit to the right through the Carry flag. If 'd' is '0', the result is placed in W. If 'd' is '1', the result is placed back in register 'f' (default). <div style="text-align: center;"> </div>

SLEEP	Enter Sleep Mode
Syntax:	[<i>label</i>] SLEEP
Operands:	None

.....continued

SLEEP		Enter Sleep Mode
Operation:		00h → WDT, 0 → WDT prescaler, 1 → \overline{TO} , 0 → \overline{PD}
Status Affected:		\overline{TO} , \overline{PD}
Description:		The Power-Down (\overline{PD}) Status bit is cleared. The Time-Out (\overline{TO}) Status bit is set. Watchdog Timer and its prescaler are cleared.

SUBLW		Subtract W from Literal
Syntax:		[<i>label</i>] SUBLW k
Operands:		$0 \leq k \leq 255$
Operation:		$k - (W) \rightarrow (W)$
Status Affected:		C, DC, Z
Description:		The W register is subtracted (two's complement method) from the 8-bit literal 'k'. The result is placed in the W register. C = 0, $W > k$ C = 1, $W \leq k$ DC = 0, $W[3:0] > k[3:0]$ DC = 1, $W[3:0] \leq k[3:0]$

SUBWF		Subtract W from f
Syntax:		[<i>label</i>] SUBWF f, d
Operands:		$0 \leq f \leq 127$ $d \in [0,1]$
Operation:		$(f) - (W) \rightarrow (\text{dest})$
Status Affected:		C, DC, Z
Description:		Subtract (two's complement method) W register from register 'f'. If 'd' is '0', the result is stored in the W register. If 'd' is '1', the result is stored back in register 'f'. C = 0, $W > f$ C = 1, $W \leq f$ DC = 0, $W[3:0] > f[3:0]$ DC = 1, $W[3:0] \leq f[3:0]$

SUBWFB		Subtract W from f with Borrow
Syntax:		[<i>label</i>] SUBWFB f {,d}
Operands:		$0 \leq f \leq 127$ $d \in [0,1]$
Operation:		$(W) - (f) - (\overline{B}) \rightarrow \text{dest}$
Status Affected:		C, DC, Z
Description:		Subtract W and the Borrow flag (Carry) from register 'f' (two's complement method). If 'd' is '0', the result is stored in W. If 'd' is '1', the result is stored back in register 'f'.

SWAPF		Swap Nibbles in f
Syntax:		[<i>label</i>] SWAPF f, d
Operands:		$0 \leq f \leq 127$ $d \in [0,1]$

.....continued	
SWAPF	Swap Nibbles in f
Operation:	(f[3:0]) → dest[7:4], (f[7:4]) → dest[3:0]
Status Affected:	None
Description:	The upper and lower nibbles of register 'f' are exchanged. If 'd' is '0', the result is placed in W. If 'd' is '1', the result is placed in register 'f' (default).

TRIS	Load TRIS Register with W
Syntax:	[<i>label</i>] TRIS f
Operands:	$5 \leq f \leq 7$
Operation:	(W) → TRIS register 'f'
Status Affected:	None
Description:	Move data from W register to TRIS register. When 'f' = 5, TRISA is loaded. When 'f' = 6, TRISB is loaded. When 'f' = 7, TRISC is loaded.

XORLW	Exclusive OR Literal with W
Syntax:	[<i>label</i>] XORLW k
Operands:	$0 \leq k \leq 255$
Operation:	(W) .XOR. k → (W)
Status Affected:	Z
Description:	The contents of W are XORed with the 8-bit literal 'k'. The result is placed in W.

XORWF	Exclusive OR W with f
Syntax:	[<i>label</i>] XORWF f, d
Operands:	$0 \leq f \leq 127$ $d \in [0,1]$
Operation:	(W) .XOR. (f) → dest
Status Affected:	Z
Description:	Exclusive OR the contents of the W register with register 'f'. If 'd' is '0', the result is stored in the W register. If 'd' is '1', the result is stored back in register 'f'.

41. ICSP™ - In-Circuit Serial Programming™

ICSP programming allows customers to manufacture circuit boards with unprogrammed devices. Programming can be done after the assembly process, allowing the device to be programmed with the most recent firmware or a custom firmware. Five pins are needed for ICSP programming:

- ICSPCLK
- ICSPDAT
- \overline{MCLR}/V_{PP}
- V_{DD}
- V_{SS}

In Program/Verify mode, the program memory, User IDs and the Configuration bits are programmed through serial communications. The ICSPDAT pin is a bidirectional I/O used for transferring the serial data and the ICSPCLK pin is the clock input. For more information on ICSP, refer to the appropriate Family Programming Specification.

41.1 High-Voltage Programming Entry Mode

The device is placed into High-Voltage Programming Entry mode by holding the ICSPCLK and ICSPDAT pins low, then raising the voltage on \overline{MCLR}/V_{PP} to V_{IH} .

41.2 Low-Voltage Programming Entry Mode

The Low-Voltage Programming Entry mode allows the PIC® Flash MCUs to be programmed using V_{DD} only, without high voltage. When the LVP Configuration bit is set to '1', the low-voltage ICSP programming entry is enabled. To disable the Low-Voltage ICSP mode, the LVP bit must be programmed to '0'.

Entry into the Low-Voltage Programming Entry mode requires the following steps:

1. \overline{MCLR} is brought to V_{IL} .
2. A 32-bit key sequence is presented on ICSPDAT, while clocking ICSPCLK.

Once the key sequence is complete, \overline{MCLR} must be held at V_{IL} for as long as Program/Verify mode is to be maintained.

If low-voltage programming is enabled ($LVP = 1$), the \overline{MCLR} Reset function is automatically enabled and cannot be disabled. See the \overline{MCLR} section for more information.

The LVP bit can only be reprogrammed to '0' by using the High-Voltage Programming mode.

41.3 Common Programming Interfaces

Connection to a target device is typically done through an ICSP header. A commonly found connector on development tools is the RJ-11 in the 6P6C (6-pin, 6-connector) configuration. See [Figure 41-1](#).

Figure 41-1. ICD RJ-11 Style Connector Interface

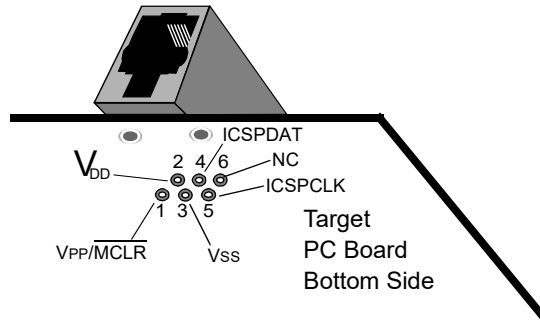

Pin Description

- 1 = V_{PP}/MCLR
- 2 = V_{DD} Target
- 3 = V_{SS} (ground)
- 4 = ICSPDAT
- 5 = ICSPCLK
- 6 = No Connect

Another connector often found in use with the PICkit™ programmers is a standard 6-pin header with 0.1 inch spacing. Refer to [Figure 41-2](#).

For additional interface recommendations, refer to the specific device programming manual prior to PCB design.

It is recommended that isolation devices be used to separate the programming pins from other circuitry. The type of isolation is highly dependent on the specific application and may include devices such as resistors, diodes, or even jumpers. See [Figure 41-3](#) for more information.

Figure 41-2. PICkit™ Programmer Style Connector Interface

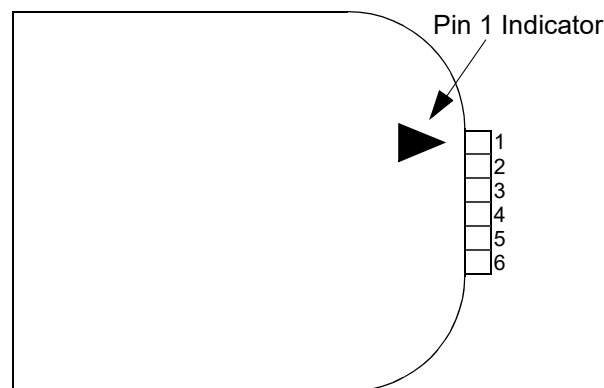

Pin Description⁽¹⁾:

- 1 = V_{PP}/\overline{MCLR}
- 2 = V_{DD} Target
- 3 = V_{SS} (ground)
- 4 = ICSPDAT
- 5 = ICSPCLK
- 6 = No Connect

Note:

- 1. The 6-pin header (0.100" spacing) accepts 0.025" square pins.

Figure 41-3. Typical Connection for ICSP™ Programming

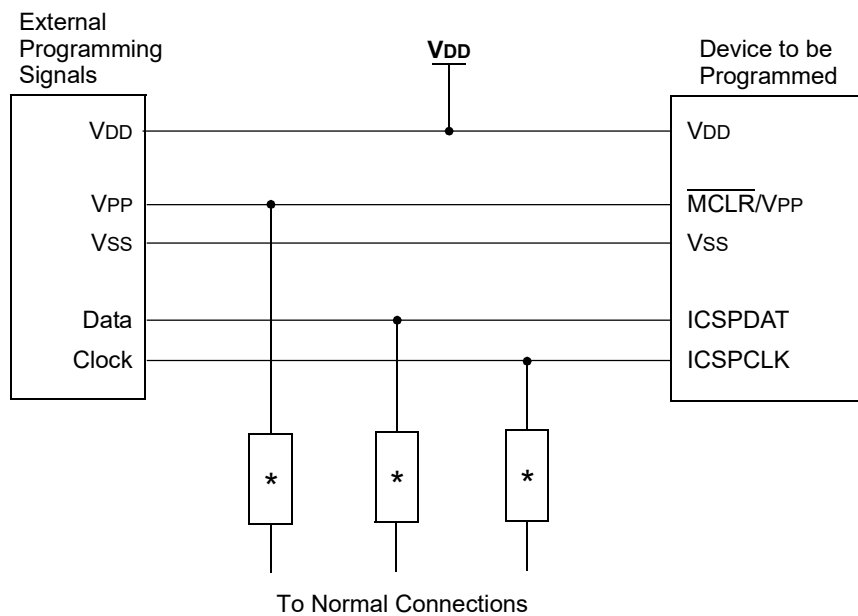

* Isolation devices (as required).

42. Register Summary

Offset	Name	Bit Pos.	7	6	5	4	3	2	1	0
0x00	INDF0	7:0	INDF0[7:0]							
0x01	INDF1	7:0	INDF1[7:0]							
0x02	PCL	7:0	PCL[7:0]							
0x03	STATUS	7:0				TO	PD	Z	DC	C
0x04	FSR0	7:0	FSR0[7:0]							
		15:8	FSR0[15:8]							
0x06	FSR1	7:0	FSR1[7:0]							
		15:8	FSR1[15:8]							
0x08	BSR	7:0	BSR[5:0]							
0x09	WREG	7:0	WREG[7:0]							
0x0A	PCLATH	7:0	PCLATH[6:0]							
0x0B	INTCON	7:0	GIE	PEIE						INTEDG
0x0C	PORTA	7:0			RA5	RA4	RA3	RA2	RA1	RA0
0x0D	PORTB	7:0	RB7	RB6	RB5	RB4				
0x0E	PORTC	7:0	RC7	RC6	RC5	RC4	RC3	RC2	RC1	RC0
0x0F	Reserved									
0x11										
0x12	TRISA	7:0			TRISA5	TRISA4	Reserved	TRISA2	TRISA1	TRISA0
0x13	TRISB	7:0	TRISB7	TRISB6	TRISB5	TRISB4				
0x14	TRISC	7:0	TRISC7	TRISC6	TRISC5	TRISC4	TRISC3	TRISC2	TRISC1	TRISC0
0x15	Reserved									
0x17										
0x18	LATA	7:0			LATA5	LATA4		LATA2	LATA1	LATA0
0x19	LATB	7:0	LATB7	LATB6	LATB5	LATB4				
0x1A	LATC	7:0	LATC7	LATC6	LATC5	LATC4	LATC3	LATC2	LATC1	LATC0
0x1B	Reserved									
0x8B										
0x8C	PIR0	7:0			TMR0IF	IOCIF				INTF
0x8D	PIR1	7:0	TMR1GIF	TMR1IF	OSFIF	CSWIF	ACTIF	SCANIF	CRCIF	NVMIF
0x8E	PIR2	7:0		CCP2IF	CCP1IF		TMR4IF	TMR2IF	TMR3GIF	TMR3IF
0x8F	PIR3	7:0					PWM2IF	PWM2PIF	PWM1IF	PWM1PIF
0x90	PIR4	7:0	RC1IF	TX1IF	CLC4IF	CLC3IF	CLC2IF	CLC1IF	CWG1IF	NCO1IF
0x91	PIR5	7:0	CM2IF	CM1IF	BCL2IF	SSP2IF	BCL1IF	SSP1IF	RC2IF	TX2IF
0x92	PIR6	7:0						ZCDIF	ADTIF	ADIF
0x93	Reserved									
0x95										
0x96	PIE0	7:0			TMR0IE	IOIE				INTE
0x97	PIE1	7:0	TMR1GIE	TMR1IE	OSFIE	CSWIE	ACTIE	SCANIE	CRCIE	NVMIE
0x98	PIE2	7:0		CCP2IE	CCP1IE		TMR4IE	TMR2IE	TMR3GIE	TMR3IE
0x99	PIE3	7:0					PWM2IE	PWM2PIE	PWM1IE	PWM1PIE
0x9A	PIE4	7:0	RC1IE	TX1IE	CLC4IE	CLC3IE	CLC2IE	CLC1IE	CWG1IE	NCO1IE
0x9B	PIE5	7:0	CM2IE	CM1IE	BCL2IE	SSP2IE	BCL1IE	SSP1IE	RC2IE	TX2IE
0x9C	PIE6	7:0						ZCDIE	ADTIE	ADIE
0x9D	Reserved									
0x010B										
0x010C	PMD0	7:0	TMR0MD	CLKRMD	IOCMD	ACTMD	SYSCMD	SCANMD	CRCMD	NVMMD
0x010D	PMD1	7:0	PWM1MD	CCP2MD	CCP1MD		TMR4MD	TMR2MD	TMR3MD	TMR1MD
0x010E	PMD2	7:0	CLC3MD	CLC2MD	CLC1MD	CWG1MD	NCO1MD			PWM2MD
0x010F	PMD3	7:0	CM2MD	CM1MD	FVRMD	MSSP2MD	MSSP1MD	UART2MD	UART1MD	CLC4MD
0x0110	PMD4	7:0				ZCDMD		DAC2MD	DAC1MD	ADCMD
0x0111	Reserved									
0x018B										

.....continued										
Offset	Name	Bit Pos.	7	6	5	4	3	2	1	0
0x018C	WDTCON0	7:0					PS[4:0]			SEN
0x018D	WDTCON1	7:0			CS[2:0]			WINDOW[2:0]		
0x018E	WDTPSL	7:0			PSCNTL[7:0]					
0x018F	WDTPSH	7:0			PSCNTH[7:0]					
0x0190	WDTTMR	7:0			TMR[4:0]			STATE	PSCNT[17:16]	
0x0191	BORCON	7:0	SBOREN							BORRDY
0x0192	PCON0	7:0	STKOVF	STKUNF	WDTWV	RWDT	RMCLR	RI	POR	BOR
0x0193	PCON1	7:0							MEMV	
0x0194	...									
0x019B	Reserved									
0x019C	TMR0L	7:0			TMR0L[7:0]					
0x019D	TMR0H	7:0			TMR0H[7:0]					
0x019E	T0CON0	7:0	EN		OUT	MD16		OUTPS[3:0]		
0x019F	T0CON1	7:0		CS[2:0]		ASYNC		CKPS[3:0]		
0x01A0	...									
0x020B	Reserved									
0x020C	FVRCON	7:0	EN	RDY	TSEN	TSRNG	CDAFVR[1:0]		ADFVR[1:0]	
0x020D	CPCON	7:0	CPON[1:0]		CPOS			CPREQ	CPT	CPRDY
0x020E	...									
0x021E	Reserved									
0x021F	ZCDCON	7:0	SEN		OUT	POL			INTP	INTN
0x0220	...									
0x028B	Reserved									
0x028C	CPUDOZE	7:0	IDLEN	DOZEN	ROI	DOE		DOZE[2:0]		
0x028D	OSCCON1	7:0			NOSC[2:0]			NDIV[3:0]		
0x028E	OSCCON2	7:0			COSC[2:0]			CDIV[3:0]		
0x028F	OSCCON3	7:0	CSWHOLD	SOSCPWR		ORDY	NOSCR			
0x0290	OSCCON4	7:0	EXTOR	HFOR	MFOR	LFOR	SOR	ADOR	SFOR	PLLR
0x0291	OSCCON5	7:0	EXTOEN	HFOEN	MFOEN	LFOEN	SOSCEN	ADOEN		PLLEN
0x0292	OSCTUNE	7:0			TUN[5:0]					
0x0293	OSCFRQ	7:0							FRQ[2:0]	
0x0294	ACTCON	7:0	ACTEN	ACTUD			ACTLOCK		ACTORS	
0x0295	Reserved									
0x0296	CLKRCON	7:0	EN			DC[1:0]		DIV[2:0]		
0x0297	CLKRCLK	7:0						CLK[3:0]		
0x0298	...									
0x030B	Reserved									
0x030C	TMR1	7:0	TMR1[7:0]			TMR1[15:8]				
0x030E	T1CON	7:0			CKPS[1:0]			SYNC	RD16	ON
0x030F	T1GCON	7:0	GE	GPOL	GTM	GSPM	GGO/DONE	GVAL		
0x0310	T1GATE	7:0					GSS[4:0]			
0x0311	T1CLK	7:0					CS[4:0]			
0x0312	TMR3	7:0	TMR3[7:0]			TMR3[15:8]				
0x0314	T3CON	7:0			CKPS[1:0]			SYNC	RD16	ON
0x0315	T3GCON	7:0	GE	GPOL	GTM	GSPM	GGO/DONE	GVAL		
0x0316	T3GATE	7:0					GSS[4:0]			
0x0317	T3CLK	7:0					CS[4:0]			
0x0318	...									
0x038B	Reserved									
0x038C	T2TMR	7:0	T2TMR[7:0]			T2TMR[15:8]				
0x038D	T2PR	7:0	T2PR[7:0]			T2PR[15:8]				
0x038E	T2CON	7:0	ON		CKPS[2:0]			OUTPS[3:0]		
0x038F	T2HLT	7:0	PSYNC	CPOL	CSYNC		MODE[4:0]			

.....continued										
Offset	Name	Bit Pos.	7	6	5	4	3	2	1	0
0x0390	T2CLKCON	7:0							CS[3:0]	
0x0391	T2RST	7:0						RSEL[4:0]		
0x0392	T4TMR	7:0				T4TMR[7:0]				
0x0393	T4PR	7:0				T4PR[7:0]				
0x0394	T4CON	7:0	ON		CKPS[2:0]			OUTPS[3:0]		
0x0395	T4HLT	7:0	PSYNC	CPOL	CSYNC			MODE[4:0]		
0x0396	T4CLKCON	7:0						CS[3:0]		
0x0397	T4RST	7:0						RSEL[4:0]		
0x0398	...									
0x040B	Reserved									
0x040C	CCPR1	7:0	CCPR[7:0]							
		15:8	CCPR[15:8]							
0x040E	CCP1CON	7:0	EN		OUT	FMT		MODE[3:0]		
0x040F	CCP1CAP	7:0						CTS[3:0]		
0x0410	CCPR2	7:0	CCPR[7:0]							
		15:8	CCPR[15:8]							
0x0412	CCP2CON	7:0	EN		OUT	FMT		MODE[3:0]		
0x0413	CCP2CAP	7:0						CTS[3:0]		
0x0414	...									
0x041E	Reserved									
0x041F	CCPTMRS0	7:0					C2TSEL[1:0]		C1TSEL[1:0]	
0x0420	...									
0x048B	Reserved									
0x048C	PWM1ERS	7:0					ERS[3:0]			
0x048D	PWM1CLK	7:0					CLK[3:0]			
0x048E	PWM1LDS	7:0					LDS[2:0]			
0x048F	PWM1PR	7:0	PR[7:0]							
		15:8	PR[15:8]							
0x0491	PWM1CPRE	7:0	CPRE[7:0]							
0x0492	PWM1PIPOS	7:0	PIPOS[7:0]							
0x0493	PWM1GIR	7:0							S1P2	S1P1
0x0494	PWM1GIE	7:0							S1P2	S1P1
0x0495	PWM1CON	7:0	EN					LD	ERSPOL	ERSNOW
0x0496	PWM1S1CFG	7:0	POL2	POL1			PPEN	MODE[2:0]		
0x0497	PWM1S1P1	7:0	P1[7:0]							
		15:8	P1[15:8]							
0x0499	PWM1S1P2	7:0	P2[7:0]							
		15:8	P2[15:8]							
0x049B	...									
0x049D	Reserved									
0x049E	PWMLOAD	7:0							MPWM2LD	MPWM1LD
0x049F	PWMEN	7:0							MPWM2EN	MPWM1EN
0x04A0	...									
0x050B	Reserved									
0x050C	PWM2ERS	7:0					ERS[3:0]			
0x050D	PWM2CLK	7:0					CLK[3:0]			
0x050E	PWM2LDS	7:0					LDS[2:0]			
0x050F	PWM2PR	7:0	PR[7:0]							
		15:8	PR[15:8]							
0x0511	PWM2CPRE	7:0	CPRE[7:0]							
0x0512	PWM2PIPOS	7:0	PIPOS[7:0]							
0x0513	PWM2GIR	7:0							S1P2	S1P1
0x0514	PWM2GIE	7:0							S1P2	S1P1
0x0515	PWM2CON	7:0	EN					LD	ERSPOL	ERSNOW
0x0516	PWM2S1CFG	7:0	POL2	POL1			PPEN	MODE[2:0]		

.....continued

Offset	Name	Bit Pos.	7	6	5	4	3	2	1	0			
0x0517	PWM2S1P1	7:0	P1[7:0]										
		15:8	P1[15:8]										
0x0519	PWM2S1P2	7:0	P2[7:0]										
		15:8	P2[15:8]										
0x051B ... 0x058B	Reserved												
0x058C	NCO1ACC	7:0	ACC[7:0]										
		15:8	ACC[15:8]										
		23:16								ACC[19:16]			
0x058F	NCO1INC	7:0	INC[7:0]										
		15:8	INC[15:8]										
		23:16								INC[19:16]			
0x0592	NCO1CON	7:0	EN		OUT	POL				PFM			
0x0593	NCO1CLK	7:0	PWS[2:0]				CKS[3:0]						
0x0594 ... 0x060B	Reserved												
0x060C	CWG1CLK	7:0								CS			
0x060D	CWG1ISM	7:0								ISM[4:0]			
0x060E	CWG1DBR	7:0								DBR[5:0]			
0x060F	CWG1DBF	7:0								DBF[5:0]			
0x0610	CWG1CON0	7:0	EN	LD				MODE[2:0]					
0x0611	CWG1CON1	7:0			IN		POLD	POLC	POLB	POLA			
0x0612	CWG1AS0	7:0	SHUTDOWN	REN	LSBD[1:0]		LSAC[1:0]						
0x0613	CWG1AS1	7:0	AS7E	AS6E	AS5E	AS4E	AS3E	AS2E	AS1E	AS0E			
0x0614	CWG1STR	7:0	OVRD	OVRC	OVRB	OVRA	STRD	STRC	STRB	STRA			
0x0615 ... 0x068B	Reserved												
0x068C	CLCnCON	7:0	EN		OUT	INTP	INTN	MODE[2:0]					
0x068D	CLCnPOL	7:0	POL				G4POL	G3POL	G2POL	G1POL			
0x068E	CLCnSEL0	7:0								D1S[6:0]			
0x068F	CLCnSEL1	7:0								D2S[6:0]			
0x0690	CLCnSEL2	7:0								D3S[6:0]			
0x0691	CLCnSEL3	7:0								D4S[6:0]			
0x0692	CLCnGLS0	7:0	G1D4T	G1D4N	G1D3T	G1D3N	G1D2T	G1D2N	G1D1T	G1D1N			
0x0693	CLCnGLS1	7:0	G2D4T	G2D4N	G2D3T	G2D3N	G2D2T	G2D2N	G2D1T	G2D1N			
0x0694	CLCnGLS2	7:0	G3D4T	G3D4N	G3D3T	G3D3N	G3D2T	G3D2N	G3D1T	G3D1N			
0x0695	CLCnGLS3	7:0	G4D4T	G4D4N	G4D3T	G4D3N	G4D2T	G4D2N	G4D1T	G4D1N			
0x0696	CLCSELECT	7:0								SLCT[3:0]			
0x0697	CLCDATA	7:0								CLC4OUT	CLC3OUT	CLC2OUT	CLC1OUT
0x0698 ... 0x070B	Reserved												
0x070C	RC1REG	7:0	RCREG[7:0]										
0x070D	TX1REG	7:0	TXREG[7:0]										
0x070E	SP1BRG	7:0	SPBRG[7:0]										
		15:8	SPBRG[15:8]										
0x0710	RC1STA	7:0	SPEN	RX9	SREN	CREN	ADDEN	FERR	OERR	RX9D			
0x0711	TX1STA	7:0	CSRC	TX9	TXEN	SYNC	SENDB	BRGH	TRMT	TX9D			
0x0712	BAUD1CON	7:0	ABDOVF	RCIDL		SCKP	BRG16		WUE	ABDEN			
0x0713 ... 0x0715	Reserved												
0x0716	RC2REG	7:0	RCREG[7:0]										
0x0717	TX2REG	7:0	TXREG[7:0]										
0x0718	SP2BRG	7:0	SPBRG[7:0]										
		15:8	SPBRG[15:8]										
0x071A	RC2STA	7:0	SPEN	RX9	SREN	CREN	ADDEN	FERR	OERR	RX9D			
0x071B	TX2STA	7:0	CSRC	TX9	TXEN	SYNC	SENDB	BRGH	TRMT	TX9D			

.....continued

Offset	Name	Bit Pos.	7	6	5	4	3	2	1	0	
0x071C	BAUD2CON	7:0	ABDOVF	RCIDL		SCKP	BRG16		WUE	ABDEN	
0x071D	...										
0x078B	Reserved										
0x078C	SSP1BUF	7:0	BUF[7:0]								
0x078D	SSP1ADD	7:0	ADD[7:0]								
0x078E	SSP1MSK	7:0	MSK[6:0]								MSK0
0x078F	SSP1STAT	7:0	SMP	CKE	D/Ā	P	S	R/W	UA	BF	
0x0790	SSP1CON1	7:0	WCOL	SSPOV	SSPEN	CKP	SSPM[3:0]				
0x0791	SSP1CON2	7:0	GCEN	ACKSTAT	ACKDT	ACKEN	RCEN	PEN	RSEN	SEN	
0x0792	SSP1CON3	7:0	ACKTIM	PCIE	SCIE	BOEN	SDAHT	SBCDE	AHEN	DHEN	
0x0793	...										
0x0795	Reserved										
0x0796	SSP2BUF	7:0	BUF[7:0]								
0x0797	SSP2ADD	7:0	ADD[7:0]								
0x0798	SSP2MSK	7:0	MSK[6:0]								MSK0
0x0799	SSP2STAT	7:0	SMP	CKE	D/Ā	P	S	R/W	UA	BF	
0x079A	SSP2CON1	7:0	WCOL	SSPOV	SSPEN	CKP	SSPM[3:0]				
0x079B	SSP2CON2	7:0	GCEN	ACKSTAT	ACKDT	ACKEN	RCEN	PEN	RSEN	SEN	
0x079C	SSP2CON3	7:0	ACKTIM	PCIE	SCIE	BOEN	SDAHT	SBCDE	AHEN	DHEN	
0x079D	...										
0x080B	Reserved										
0x080C	CM1CON0	7:0	EN	OUT		POL			HYS	SYNC	
0x080D	CM1CON1	7:0							INTP	INTN	
0x080E	CM1NCH	7:0							NCH[2:0]		
0x080F	CM1PCH	7:0							PCH[2:0]		
0x0810	CM2CON0	7:0	EN	OUT		POL			HYS	SYNC	
0x0811	CM2CON1	7:0							INTP	INTN	
0x0812	CM2NCH	7:0							NCH[2:0]		
0x0813	CM2PCH	7:0							PCH[2:0]		
0x0814	...										
0x081E	Reserved										
0x081F	CMOUT	7:0							C2OUT	C1OUT	
0x0820	...										
0x088B	Reserved										
0x088C	DAC1CON	7:0	EN	REFRNG	OE[1:0]		PSS[1:0]			NSS	
0x088D	DAC1DATL	7:0	DAC1R[7:0]								
0x088E	...										
0x088F	Reserved										
0x0890	DAC2CON	7:0	EN				PSS[1:0]			NSS	
0x0891	DAC2DATL	7:0	DAC2R[7:0]								
0x0892	...										
0x1C8B	Reserved										
0x1C8C	NVMADR	7:0	NVMADR[7:0]								
		15:8	NVMADR[14:8]								
0x1C8E	NVMDAT	7:0	NVMDAT[7:0]								
		15:8	NVMDAT[13:8]								
0x1C90	NVMCON1	7:0		NVMREGS	LWLO	FREE	WRERR	WREN	WR	RD	
0x1C91	NVMCON2	7:0	NVMCON2[7:0]								
0x1C92	SCANHADR	7:0	SCANHADRL[7:0]								
		15:8	SCANHADRH[7:0]								
0x1C94	Reserved										
0x1C95	SCANLADR	7:0	SCANLADRL[7:0]								
		15:8	SCANLADRH[7:0]								
0x1C97	Reserved										

.....continued

Offset	Name	Bit Pos.	7	6	5	4	3	2	1	0	
0x1C98	SCANCON0	7:0	EN	SGO	BUSY	DABORT	INTM			MD[1:0]	
0x1C99	SCANTRIG	7:0								TSEL[3:0]	
0x1C9A	CRCDATA	7:0								CRCDATA[7:0]	
		15:8								CRCDATAH[7:0]	
		23:16									CRCDATAU[7:0]
		31:24									CRCDATAT[7:0]
0x1C9E	CRCOUT	7:0								CRCOUTL[7:0]	
		15:8								CRCOUTH[7:0]	
		23:16									CRCOUTU[7:0]
		31:24									CRCOUTT[7:0]
0x1C9E	CRCSHIFT	7:0								CRCSHIFTL[7:0]	
		15:8								CRCSHIFTH[7:0]	
		23:16									CRCSHIFTU[7:0]
		31:24									CRCSHIFTT[7:0]
0x1C9E	CRCXOR	7:0								CRCXORL[7:0]	
		15:8								CRCXORH[7:0]	
		23:16									CRCXORU[7:0]
		31:24									CRCXORT[7:0]
0x1CA2	CRCCON0	7:0	EN	GO	BUSY	ACCM		SETUP[1:0]	SHIFTM	FULL	
0x1CA3	CRCCON1	7:0							PLEN[4:0]		
0x1CA4	CRCCON2	7:0							DLEN[4:0]		
0x1CA5	Reserved										
...	Reserved										
0x1D0B	Reserved										
0x1D0C	ADLTH	7:0								LTH[7:0]	
		15:8								LTH[15:8]	
0x1D0E	ADUTH	7:0								UTH[7:0]	
		15:8								UTH[15:8]	
0x1D10	ADERR	7:0								ERR[7:0]	
		15:8								ERR[15:8]	
0x1D12	ADSTPT	7:0								STPT[7:0]	
		15:8								STPT[15:8]	
0x1D14	ADFLTR	7:0								FLTR[7:0]	
		15:8								FLTR[15:8]	
0x1D16	ADACC	7:0								ACC[7:0]	
		15:8								ACC[15:8]	
		23:16									ACC[17:16]
0x1D19	ADCNT	7:0								CNT[7:0]	
0x1D1A	ADRPT	7:0								RPT[7:0]	
0x1D1B	ADPREV	7:0								PREV[7:0]	
		15:8								PREV[15:8]	
0x1D1D	ADRES	7:0								RES[7:0]	
		15:8								RES[15:8]	
0x1D1F	ADPCH	7:0								PCH[5:0]	
0x1D20	ADNCH	7:0								NCH[5:0]	
0x1D21	ADACQ	7:0								ACQ[7:0]	
		15:8								ACQ[12:8]	
0x1D23	ADCAP	7:0								CAP[4:0]	
0x1D24	ADPRE	7:0								PRE[7:0]	
		15:8								PRE[12:8]	
0x1D26	ADCON0	7:0	ON	CONT		CS		FM[1:0]	IC	GO	
0x1D27	ADCON1	7:0	PPOL	IPEN	GPOL				PCSC	DSEN	
0x1D28	ADCON2	7:0	PSIS		CRS[2:0]		ACLR			MD[2:0]	
0x1D29	ADCON3	7:0			CALC[2:0]		SOI			TMD[2:0]	
0x1D2A	ADSTAT	7:0	AOV	UTHR	LTHR	MATH				STAT[2:0]	
0x1D2B	ADREF	7:0								PREF[1:0]	
0x1D2C	ADACT	7:0								ACT[4:0]	
0x1D2D	ADCLK	7:0								CS[5:0]	
0x1D2E	ADCG1A	7:0			CGA5	CGA4			CGA2	CGA1	CGA0
0x1D2F	ADCG1B	7:0	CGB7	CGB6	CGB5	CGB4					

.....continued

Offset	Name	Bit Pos.	7	6	5	4	3	2	1	0
0x1D30	ADCG1C	7:0	CGC7	CGC6	CGC5	CGC4	CGC3	CGC2	CGC1	CGC0
0x1D31	Reserved									
...										
0x1D8B										
0x1D8C	RA0PPS	7:0					RA0PPS[5:0]			
0x1D8D	RA1PPS	7:0					RA1PPS[5:0]			
0x1D8E	RA2PPS	7:0					RA2PPS[5:0]			
0x1D8F	Reserved									
0x1D90		RA4PPS	7:0				RA4PPS[5:0]			
0x1D91		RA5PPS	7:0				RA5PPS[5:0]			
0x1D92	Reserved									
...										
0x1D97										
0x1D98	RB4PPS	7:0					RB4PPS[5:0]			
0x1D99	RB5PPS	7:0					RB5PPS[5:0]			
0x1D9A	RB6PPS	7:0					RB6PPS[5:0]			
0x1D9B	RB7PPS	7:0					RB7PPS[5:0]			
0x1D9C	RC0PPS	7:0					RC0PPS[5:0]			
0x1D9D	RC1PPS	7:0					RC1PPS[5:0]			
0x1D9E	RC2PPS	7:0					RC2PPS[5:0]			
0x1D9F	RC3PPS	7:0					RC3PPS[5:0]			
0x1DA0	RC4PPS	7:0					RC4PPS[5:0]			
0x1DA1	RC5PPS	7:0					RC5PPS[5:0]			
0x1DA2	RC6PPS	7:0					RC6PPS[5:0]			
0x1DA3	RC7PPS	7:0					RC7PPS[5:0]			
0x1DA4	Reserved									
...										
0x1E0B										
0x1E0C	PPSLOCK	7:0								PPSLOCKED
0x1E0D	INTPPS	7:0				PORT[2:0]			PIN[2:0]	
0x1E0E	TOCKIPPS	7:0				PORT[2:0]			PIN[2:0]	
0x1E0F	T1CKIPPS	7:0				PORT[2:0]			PIN[2:0]	
0x1E10	T1GPPS	7:0				PORT[2:0]			PIN[2:0]	
0x1E11	T3CKIPPS	7:0				PORT[2:0]			PIN[2:0]	
0x1E12	T3GPPS	7:0				PORT[2:0]			PIN[2:0]	
0x1E13	Reserved									
...										
0x1E18										
0x1E19	T2INPPS	7:0				PORT[2:0]			PIN[2:0]	
0x1E1A	T4INPPS	7:0				PORT[2:0]			PIN[2:0]	
0x1E1B	Reserved									
...										
0x1E1D										
0x1E1E	CCP1PPS	7:0				PORT[2:0]			PIN[2:0]	
0x1E1F	CCP2PPS	7:0				PORT[2:0]			PIN[2:0]	
0x1E20	Reserved									
...										
0x1E23										
0x1E24	PWMIN0PPS	7:0				PORT[2:0]			PIN[2:0]	
0x1E25	PWMIN1PPS	7:0				PORT[2:0]			PIN[2:0]	
0x1E26	PWM1ERSPPS	7:0				PORT[2:0]			PIN[2:0]	
0x1E27	PWM2ERSPPS	7:0				PORT[2:0]			PIN[2:0]	
0x1E28	Reserved									
...										
0x1E38										
0x1E39	CWG1PPS	7:0				PORT[2:0]			PIN[2:0]	
0x1E3A	Reserved									
...										
0x1E3C										
0x1E3D	CLCIN0PPS	7:0				PORT[2:0]			PIN[2:0]	
0x1E3E	CLCIN1PPS	7:0				PORT[2:0]			PIN[2:0]	

.....continued

Offset	Name	Bit Pos.	7	6	5	4	3	2	1	0
0x1EEB	Reserved									
0x1EEC	RC4I2C	7:0		SLEW	PU[1:0]				TH[1:0]	
0x1EED	RC5I2C	7:0		SLEW	PU[1:0]				TH[1:0]	
0x1EEE ... 0x8004	Reserved									
0x8005	REVISIONID	7:0	MJRREV[1:0]		MNRREV[5:0]					
		15:8			Reserved	Reserved	MJRREV[5:2]			
0x8006	DEVICEID	7:0	DEV[7:0]							
		15:8			Reserved	Reserved	DEV[11:8]			
0x8007	CONFIG1	7:0	RSTOSC[2:0]			FEXTOSC[2:0]				
		15:8			FCMEN	VDDAR	CSWEN			CLKOUTEN
0x8008	CONFIG2	7:0	BOREN[1:0]		LPBOREN	PWRTS[1:0]			MCLRE	
		15:8			DEBUG	STVREN	PPS1WAY	ZCD	BORV	DACAUTOEN
0x8009	CONFIG3	7:0	WDTE[1:0]			WDTCP[4:0]				
		15:8			WDTCCS[2:0]			WDTCCWS[2:0]		
0x800A	CONFIG4	7:0	WRTAPP			SAFEN	BBEN	BBSIZE[2:0]		
		15:8			LVP		WRTSAF	WRTD	WRTC	WRTB
0x800B	CONFIG5	7:0							CPD	CP
		15:8								

43. Electrical Specifications

43.1 Absolute Maximum Ratings^(†)

Parameter	Rating	
Ambient temperature under bias	-40°C to +125°C	
Storage temperature	-65°C to +150°C	
Voltage on pins with respect to V_{SS}		
• on V _{DD} pin:	-0.3V to +6.5V	
• on MCLR pin:	-0.3V to +9.0V	
• on all other pins:	-0.3V to (V _{DD} + 0.3V)	
Maximum current⁽¹⁾		
• on V _{SS} pin	-40°C ≤ T _A ≤ +85°C 85°C < T _A ≤ +125°C	300 mA 120 mA
• on V _{DD} pin	-40°C ≤ T _A ≤ +85°C 85°C < T _A ≤ +125°C	250 mA 85 mA
• on any standard I/O pin		±25 mA
Clamp current, I _K (V _{PIN} < 0 or V _{PIN} > V _{DD})		±20 mA
Total power dissipation ⁽²⁾		800 mW

Notes:

- Maximum current rating requires even load distribution across I/O pins. Maximum current rating may be limited by the device package power dissipation characterizations, see [Thermal Characteristics](#) to calculate device specifications.

- Power dissipation is calculated as follows:

$$P_{DIS} = V_{DD} \times \{I_{DD} - \sum I_{OH}\} + \sum \{(V_{DD} - V_{OH}) \times I_{OH}\} + \sum (V_{OI} \times I_{OL})$$

- Internal Power Dissipation is calculated as follows:

$$P_{INTERNAL} = I_{DD} \times V_{DD}$$

where I_{DD} is current to run the chip alone without driving any load on the output pins.

- I/O Power Dissipation is calculated as follows:

$$P_{I/O} = \sum (I_{OL} \times V_{OL}) + \sum (I_{OH} \times (V_{DD} - V_{OH}))$$

- Derated Power is calculated as follows:

$$P_{DER} = PD_{MAX}(T_J - T_A) / \theta_{JA}$$

where T_A = Ambient Temperature, T_J = Junction Temperature.

CAUTION

Notice: Stresses above those listed under the *Absolute Maximum Ratings* section may cause permanent damage to the device. This is a stress rating only and functional operation of the device at those or any other conditions above those indicated in the operation listings of this specification is not implied. Exposure above maximum rating conditions for extended periods may affect device reliability.

43.2 Standard Operating Conditions

The standard operating conditions for any device are defined as:

Parameter	Condition
Operating Voltage:	$V_{DDMIN} \leq V_{DD} \leq V_{DDMAX}$
Operating Temperature:	$T_{AMIN} \leq T_A \leq T_{AMAX}$

Parameter	Ratings
V_{DD} — Operating Supply Voltage⁽¹⁾	
V_{DDMIN} ($F_{OSC} \leq 16$ MHz)	+1.8V
V_{DDMIN} ($F_{OSC} \leq 32$ MHz)	+2.5V
V_{DDMAX}	+5.5V
T_A — Operating Ambient Temperature Range	
Industrial Temperature	T_{A_MIN} -40°C T_{A_MAX} +85°C
Extended Temperature	T_{A_MIN} -40°C T_{A_MAX} +125°C

Note:

- See Parameter **D002**, DC Characteristics: Supply Voltage.

Figure 43-1. Voltage Frequency Graph, $-40^{\circ}\text{C} \leq T_A \leq +125^{\circ}\text{C}$

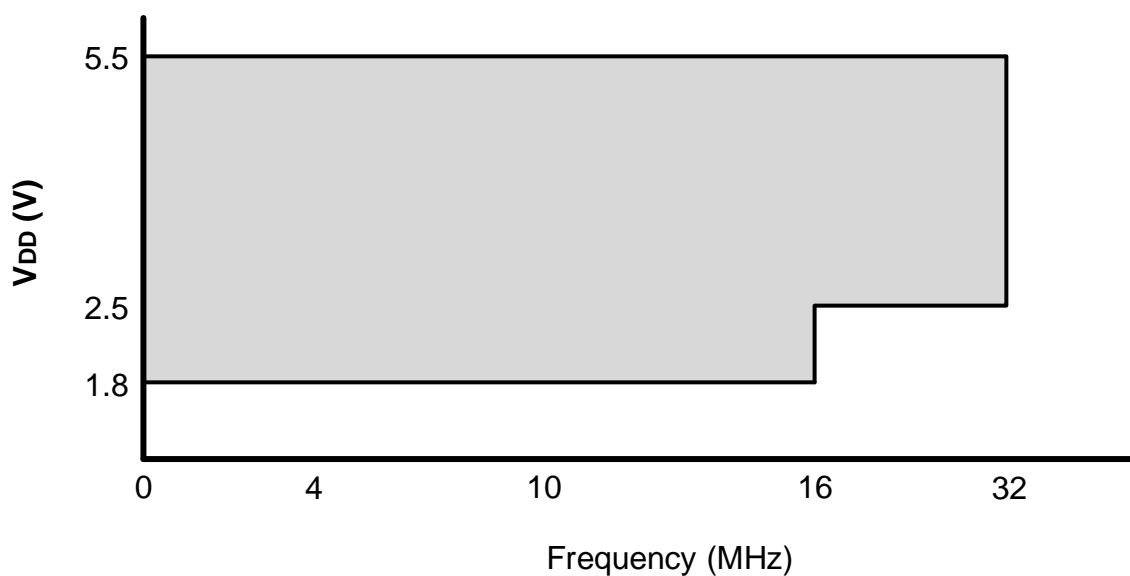

Notes:

- The shaded region indicates the permissible combinations of voltage and frequency.
- Refer to the **“External Clock/Oscillator Timing Requirements”** section for each Oscillator mode’s supported frequencies.

43.3 DC Characteristics

43.3.1 Supply Voltage

Table 43-1.

Standard Operating Conditions (unless otherwise stated)							
Param. No.	Sym.	Characteristic	Min.	Typ.†	Max.	Units	Conditions
Supply Voltage							
D002	V _{DD}		1.8	—	5.5	V	F _{OSC} ≤ 16 MHz
			2.5	—	5.5	V	F _{OSC} > 16 MHz
RAM Data Retention⁽¹⁾							
D003	V _{DR}		1.7	—	—	V	Device in Sleep mode
Power-on Reset Release Voltage⁽²⁾							
D004	V _{POR}		—	1.6	—	V	BOR and LPBOR disabled ⁽³⁾
Power-on Reset Rearm Voltage⁽²⁾							
D005	V _{PORR}		—	1	—	V	BOR and LPBOR disabled ⁽³⁾
V_{DD} Rise Rate to ensure internal Power-on Reset signal⁽²⁾							
D006	S _{VDD}		0.05	—	—	V/ms	BOR and LPBOR disabled ⁽³⁾
† Data in “Typ.” column is at 3.0V, 25°C unless otherwise stated. These parameters are for design guidance only and are not tested.							
Notes:							
1. This is the limit to which V _{DD} can be lowered in Sleep mode without losing RAM data.							
2. See the following figure, POR and POR REARM with Slow Rising V _{DD} .							
3. See the “Reset, WDT, Oscillator Start-up Timer, Brown-Out Reset and Low-Power Brown-Out Reset Specifications” section for BOR and LPBOR trip point information.							

Figure 43-2. POR and POR Rearm with Slow Rising V_{DD}

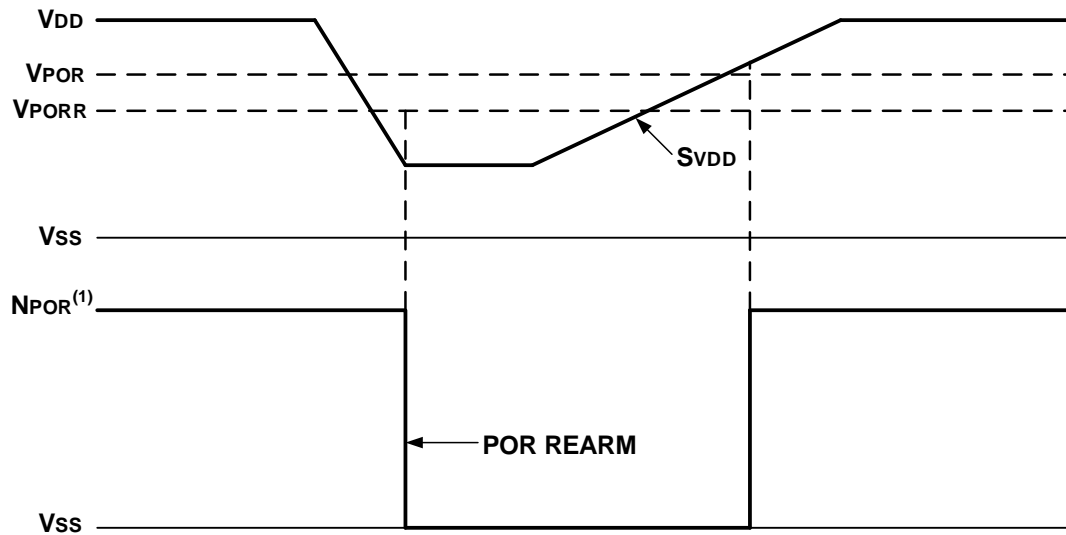

Note:

1. When N_{POR} is low, the device is held in Reset.

43.3.2 Supply Current (I_{DD})^(1,2)

Table 43-2.

Standard Operating Conditions (unless otherwise stated)								
Param. No.	Sym.	Device Characteristics	Min.	Typ.†	Max.	Units	Conditions	
							V_{DD}	Note
D100	$I_{DD_{XT4}}$	XT = 4 MHz	—	628	862	μA	3.0V	
D100A	$I_{DD_{XT4}}$	XT = 4 MHz	—	487	696	μA	3.0V	All PMD bits are 1
D101	$I_{DD_{HFO16}}$	HFINTOSC = 16 MHz	—	2.4	2.9	mA	3.0V	
D101A	$I_{DD_{HFO16}}$	HFINTOSC = 16 MHz	—	1.7	2.3	mA	3.0V	All PMD bits are 1
D102	$I_{DD_{HFOPLL}}$	HFINTOSC = 32 MHz	—	4.7	5.5	mA	3.0V	
D102A	$I_{DD_{HFOPLL}}$	HFINTOSC = 32 MHz	—	3.3	4.2	mA	3.0V	All PMD bits are 1
D103	$I_{DD_{HSPLL64}}$	HS+PLL = 32 MHz	—	4.4	5.2	mA	3.0V	
D103A	$I_{DD_{HSPLL64}}$	HS+PLL = 32 MHz	—	3.4	4.3	mA	3.0V	All PMD bits are 1
D104	$I_{DD_{IDLE}}$	Idle mode, HFINTOSC = 16 MHz	—	1.26	1.7	mA	3.0V	
D105	$I_{DD_{DOZE}}^{(3)}$	Doze mode, HFINTOSC = 16 MHz, Doze Ratio = 16	—	1.35	1.8	mA	3.0V	

.....continued

Standard Operating Conditions (unless otherwise stated)								
Param. No.	Sym.	Device Characteristics	Min.	Typ.†	Max.	Units	Conditions	
							V _{DD}	Note
† Data in “Typ.” column is at 3.0V, 25°C unless otherwise stated. These parameters are for design guidance only and are not tested.								
Notes:								
1. The test conditions for all I _{DD} measurements in Active Operation mode are: OSC1 = external square wave, from rail-to-rail; all I/O pins are outputs driven low; $\overline{MCLR} = V_{DD}$; WDT disabled.								
2. The supply current is mainly a function of the operating voltage and frequency. Other factors, such as I/O pin loading and switching rate, oscillator type, internal code execution pattern and temperature, also have an impact on the current consumption.								
3. $I_{DD_{DOZE}} = [I_{DD_{IDLE}} * (N-1)/N] + I_{DD_{HFO}} 16/N$ where N = Doze Ratio (see the CPUDOZE register).								
4. PMD bits are all in the Default state, no modules are disabled.								

43.3.3 Power-Down Current (I_{PD})^(1,2,3)

Table 43-3.

Standard Operating Conditions (unless otherwise stated)									
Param. No.	Sym.	Device Characteristics	Min.	Typ.†	Max. +85°C	Max. +125°C	Units	Conditions	
								V _{DD}	Note
D200	I _{PD}	I _{PD} Base	—	0.13	2	6	µA	3.0V	
D201	I _{PD_WDT}	Low-Frequency Internal Oscillator/WDT	—	0.55	3	7	µA	3.0V	
D202	I _{PD_SOSC}	Secondary Oscillator (S _{Osc})	—	1.2	4.6	9.2	µA	3.0V	
D203	I _{PD_LPBOR}	Low-Power Brown-out Reset (LPBOR)	—	0.25	2.5	7.3	µA	3.0V	
D204	I _{PD_FVR_BUF1}	FVR Buffer 1 (ADC)	—	171	325	350	µA	3.0V	
D204A	I _{PD_FVR_BUF2}	FVR Buffer 2 (DAC/ CMP)	—	40	68	77	µA	3.0V	
D205	I _{PD_BOR}	Brown-out Reset (BOR)	—	27	46	53	µA	3.0V	
D207	I _{PD_ADCA}	ADC - Active	—	0.13	2	6	µA	3.0V	ADC is not converting (Note 4)
D208	I _{PD_CMP}	Comparator1	—	27	43	49	µA	3.0V	
D208A	I _{PD_CMP}	Comparator2	—	27	43	49	µA	3.0V	

* These parameters are characterized but not tested.

† Data in “Typ.” column is at 3.0V, 25°C unless otherwise stated. These parameters are for design guidance only and are not tested.

Notes:

1. The peripheral current is the sum of the base I_{DD} and the additional current consumed when this peripheral is enabled. The peripheral Δ current can be determined by subtracting the base I_{DD} or I_{PD} current from this limit. Max. values will be used when calculating total current consumption.
2. The power-down current in Sleep mode does not depend on the oscillator type. Power-down current is measured with the part in Sleep mode with all I/O pins in High-Impedance state and tied to V_{SS}.
3. All peripheral currents listed are on a per-peripheral basis if more than one instance of a peripheral is available.
4. ADC clock source is ADCRC.

43.3.4 I/O Ports

Table 43-4.

Standard Operating Conditions (unless otherwise stated)							
Param. No.	Sym.	Device Characteristics	Min.	Typ.†	Max.	Units	Conditions
Input Low-Voltage							
	V _{IL}	I/O PORT:					
D300		• with TTL buffer	—	—	0.8	V	4.5V ≤ V _{DD} ≤ 5.5V
D301			—	—	0.15 V _{DD}	V	1.8V ≤ V _{DD} < 4.5V
D302		• with Schmitt Trigger buffer	—	—	0.2 V _{DD}	V	2.0V ≤ V _{DD} ≤ 5.5V
D303		• with I ² C levels	—	—	0.3 V _{DD}	V	1.8V ≤ V _{DD} ≤ 5.5V
D304		• with SMBus 2.0	—	—	0.8	V	2.7V ≤ V _{DD} ≤ 5.5V
D305		• with SMBus 3.0	—	—	0.8	V	
D306		MCLR	—	—	0.2 V _{DD}	V	
High/Low-Voltage							
	V _{IH}	I/O PORT:					
D320		• with TTL buffer	2.0	—	—	V	4.5V ≤ V _{DD} ≤ 5.5V
D321			0.25 V _{DD} + 0.8	—	—	V	1.8V ≤ V _{DD} < 4.5V
D322		• with Schmitt Trigger buffer	0.8 V _{DD}	—	—	V	2.0V ≤ V _{DD} ≤ 5.5V
D323		• with I ² C levels	0.7 V _{DD}	—	—	V	
D324		• with SMBus 2.0	2.1	—	—	V	2.7V ≤ V _{DD} ≤ 5.5V
D325		• with SMBus 3.0	1.35	—	—	V	
D326		MCLR	0.7 V _{DD}	—	—	V	
Input Leakage Current⁽¹⁾							
D340	I _{IL}	I/O PORTS	—	±5	±125	nA	V _{SS} ≤ V _{PIN} ≤ V _{DD} , Pin at high-impedance, 85°C
D341			—	±5	±1000	nA	V _{SS} ≤ V _{PIN} ≤ V _{DD} , Pin at high-impedance, 125°C
D342		MCLR ⁽²⁾	—	±50	±200	nA	V _{SS} ≤ V _{PIN} ≤ V _{DD} , Pin at high-impedance, 85°C
Weak Pull-up Current							
D350	I _{PUR}		80	140	200	μA	V _{DD} = 3.0V, V _{PIN} = V _{SS}
Output Low-Voltage							
D360	V _{OL}	I/O PORTS	—	—	0.6	V	I _{OL} = 10.0 mA, V _{PIN} = 3.0V
Output High-Voltage							

.....continued

Standard Operating Conditions (unless otherwise stated)

Param. No.	Sym.	Device Characteristics	Min.	Typ.†	Max.	Units	Conditions
D370	V _{OH}	I/O PORTS	V _{DD} - 0.7	—	—	V	I _{OH} = 6.0 mA, V _{PIN} = 3.0V

All I/O Pins

D380	C _{IO}		—	5	50	pF	
------	-----------------	--	---	---	----	----	--

† Data in “Typ” column is at 3.0V, 25°C unless otherwise stated. These parameters are for design guidance only and are not tested.

Notes:

1. Negative current is defined as current sourced by the pin.
2. The leakage current on the $\overline{\text{MCLR}}$ pin is strongly dependent on the applied voltage level. The specified levels represent normal operating conditions. Higher leakage current may be measured at different input voltages.

43.3.5 Memory Programming Specifications

Table 43-5.

Standard Operating Conditions (unless otherwise stated)

Param No.	Sym.	Device Characteristics	Min.	Typ†	Max.	Units	Conditions
Data EEPROM Memory Specifications							
MEM20	E _D	DataEE Byte Endurance	100k	—	—	E/W	-40°C ≤ T _A ≤ +85°C
MEM21	T _{D_RET}	Characteristic Retention	—	40	—	Year	Provided no other specifications are violated
MEM23	V _{D_RW}	V _{DD} for Read or Erase/Write operation	V _{DDMIN}	—	V _{DDMAX}	V	
MEM24	T _{D_BEW}	Byte Erase and Write Cycle Time	—	—	11	ms	
Program Flash Memory Specifications							
MEM30	E _p	Flash Memory Cell Endurance	10k	—	—	E/W	-40°C ≤ T _A ≤ +85°C (Note 1)
MEM32	T _{P_RET}	Characteristic Retention	—	40	—	Year	Provided no other specifications are violated
MEM33	V _{P_RD}	V _{DD} for Read operation	V _{DDMIN}	—	V _{DDMAX}	V	
MEM34	V _{P_REW}	V _{DD} for Row Erase or Write operation	V _{DDMIN}	—	V _{DDMAX}	V	
MEM35	T _{P_REW}	Self-Timed Page Write	—	—	—	ms	
MEM36	T _{SE}	Self-Timed Page Erase	—	—	—	ms	
MEM37	T _{P_WRD}	Self-Timed Word Write	—	—	—	µs	

† Data in “Typ” column is at 3.0V, 25°C unless otherwise stated. These parameters are for design guidance only and are not tested.

Note:

1. Flash Memory Cell Endurance for the Flash memory is defined as: One Row Erase operation and one Self-Timed Write.

43.3.6 Thermal Characteristics

Table 43-6.

Standard Operating Conditions (unless otherwise stated)					
Param No.	Sym.	Characteristic	Typ.	Units	Conditions
TH01	θ_{JA}	Thermal Resistance Junction to Ambient	—	°C/W	14-pin PDIP package
			—	°C/W	14-pin SOIC package
			—	°C/W	14-pin TSSOP package
			—	°C/W	16-pin VQFN 4x4 mm package
			—	°C/W	20-pin PDIP package
			—	°C/W	20-pin SOIC package
			—	°C/W	20-pin SSOP package
			—	°C/W	20-pin VQFN 4x4 mm package
TH02	T_{JMAX}	Maximum Junction Temperature	150	°C	
TH03	PD	Power Dissipation	—	W	$PD = P_{INTERNAL} + P_{I/O}$
TH04	$P_{INTERNAL}$	Internal Power Dissipation	—	W	$P_{INTERNAL} = I_{DD} \times V_{DD}^{(1)}$
TH05	$P_{I/O}$	I/O Power Dissipation	—	W	$P_{I/O} = \Sigma(I_{OL} * V_{OL}) + \Sigma(I_{OH} * (V_{DD} - V_{OH}))$
TH06	P_{DER}	Derated Power	—	W	$P_{DER} = PD_{MAX} (T_J - T_A) / \theta_{JA}^{(2)}$

Notes:

- I_{DD} is current to run the chip alone without driving any load on the output pins.
- T_A = Ambient Temperature, T_J = Junction Temperature.

43.4 AC Characteristics

Figure 43-3. Load Conditions

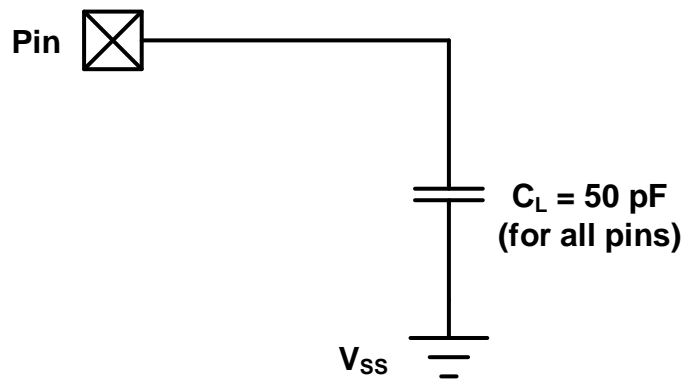

43.4.1 External Clock/Oscillator Timing Requirements

Figure 43-4. Clock Timing

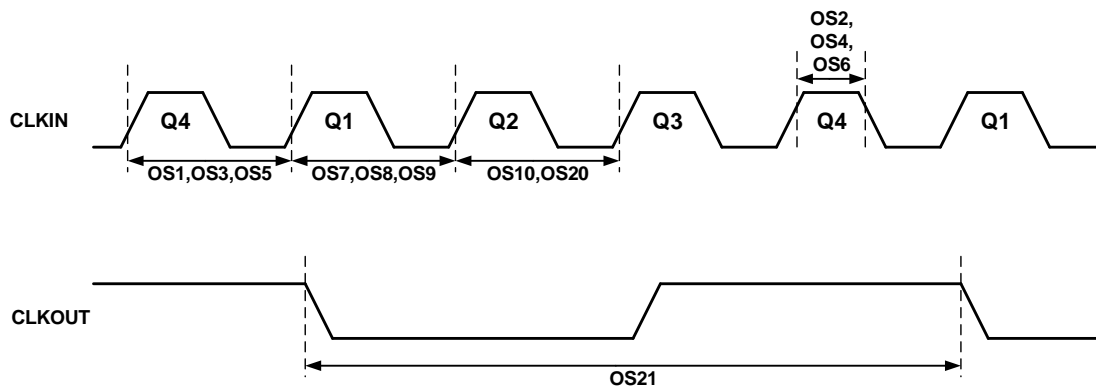

Table 43-7.

Standard Operating Conditions (unless otherwise stated)							
Param No.	Sym.	Characteristic	Min.	Typ. †	Max.	Units	Conditions
ECL Oscillator							
OS1	F_{ECL}	Clock Frequency	—	—	1	MHz	
OS2	T_{ECL_DC}	Clock Duty Cycle	40	—	60	%	
ECH Oscillator							
OS5	F_{ECH}	Clock Frequency	—	—	32	MHz	$V_{DD} \geq 2.5V$
			—	—	16	MHz	$V_{DD} < 2.5V$
OS6	T_{ECH_DC}	Clock Duty Cycle	40	—	60	%	
LP Oscillator							
OS7	F_{LP}	Clock Frequency	—	—	100	kHz	(Note 4)
XT Oscillator							
OS8	F_{XT}	Clock Frequency	—	—	4	MHz	(Note 4)
HS Oscillator							
OS9	F_{HS}	Clock Frequency	—	—	20	MHz	$V_{DD} > 2.5V$ (Note 4)
Secondary Oscillator							
OS10	F_{SEC}	Clock Frequency	—	32.768	—	kHz	(Note 4)
System Oscillator							
OS20	F_{OSC}	System Clock Frequency	—	—	32	MHz	(Note 2, Note 3)
OS21	F_{CY}	Instruction Frequency	—	$F_{OSC}/4$	—	MHz	
OS22	T_{CY}	Instruction Period	125	$1/F_{CY}$	—	ns	

.....continued

Standard Operating Conditions (unless otherwise stated)							
Param No.	Sym.	Characteristic	Min.	Typ. †	Max.	Units	Conditions
Notes:							
1. Instruction cycle period (TCY) equals four times the input oscillator time base period. All specified values are based on characterization data for that particular oscillator type under standard operating conditions with the device executing code. Exceeding these specified limits may result in an unstable oscillator operation and/or higher than expected current consumption. All devices are tested to operate at “min” values with an external clock applied to OSC1 pin. When an external clock input is used, the “max” cycle time limit is “DC” (no clock) for all devices.							
2. The system clock frequency (F_{OSC}) is selected by the “main clock switch controls” as described in the “ Power Saving Operation Modes ” section.							
3. The system clock frequency (F_{OSC}) must meet the voltage requirements defined in the “ Standard Operating Conditions ” section.							
4. LP, XT and HS oscillator modes require an appropriate crystal or resonator to be connected to the device. For clocking the device with the external square wave, one of the EC mode selections must be used.							

43.4.2 Internal Oscillator Parameters⁽¹⁾

Table 43-8.

Standard Operating Conditions (unless otherwise stated)							
Param No.	Sym.	Characteristic	Min.	Typ. †	Max.	Units	Conditions
OS50	F_{HFOSC}	Precision Calibrated HFINTOSC Frequency	—	4 8 16 32	—	MHz	(Note 2)
OS51	$F_{HFOSCLP}$	Low-Power Optimized HFINTOSC Frequency	—	1	—	MHz	-40°C to 85°C
			—	2	—	MHz	-40°C to 85°C
			—	1	—	MHz	-40°C to 125 °C
			—	2	—	MHz	-40°C to 125 °C
OS52	F_{MFOSC}	Internal Calibrated MFINTOSC Frequency	—	500	—	kHz	
OS53*	F_{LFOSC}	Internal LFINTOSC Frequency	—	31	—	kHz	
OS54*	$T_{HFOSCST}$	HFINTOSC Wake-up from Sleep Start-up Time	—	—	—	µs	
OS56	$T_{LFOSCST}$	LFINTOSC Wake-up from Sleep Start-up Time	—	—	—	ms	

* These parameters are characterized but not tested.

† Data in “Typ” column is at 3.0V, 25°C unless otherwise stated. These parameters are for design guidance only and are not tested.

Notes:

- To ensure these oscillator frequency tolerances, V_{DD} and V_{SS} must be capacitively decoupled as close to the device as possible. 0.1 µF and 0.01 µF values in parallel are recommended.
- See the figure below.

Figure 43-5. Precision Calibrated HFINTOSC Frequency Accuracy Over Device V_{DD} and Temperature

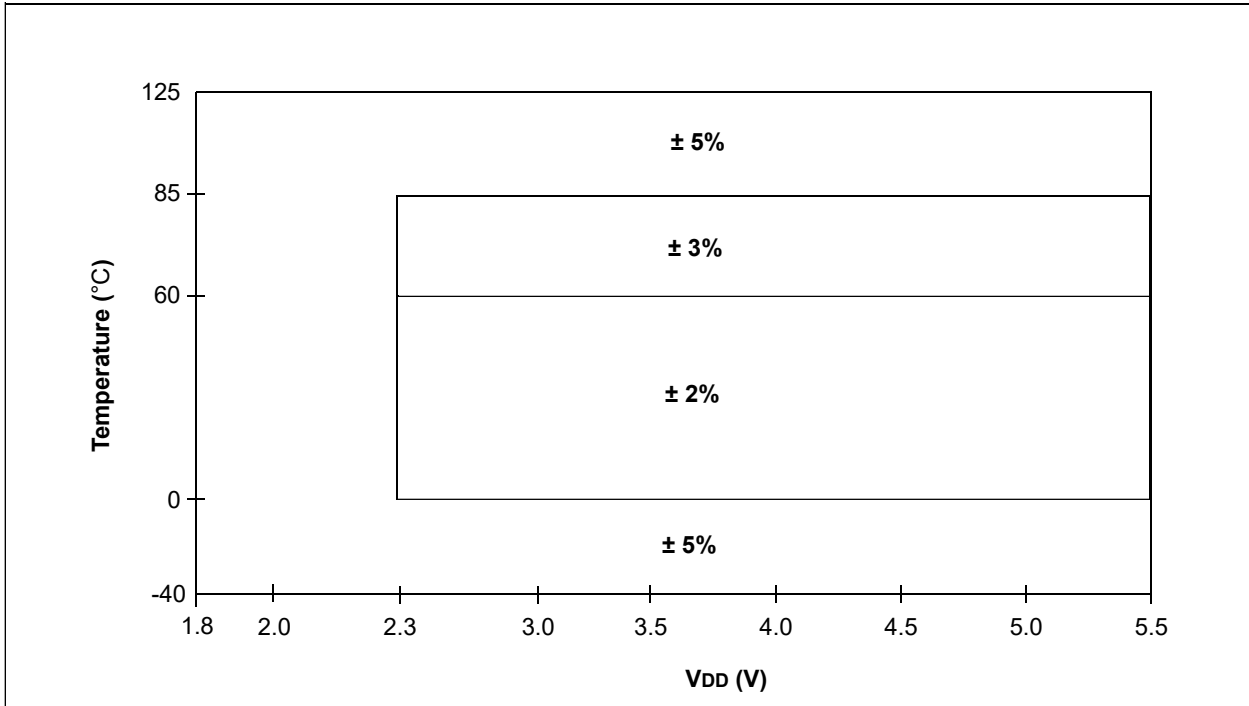

43.4.3 I/O and CLKOUT Timing Specifications

Figure 43-6. CLKOUT and I/O Timing

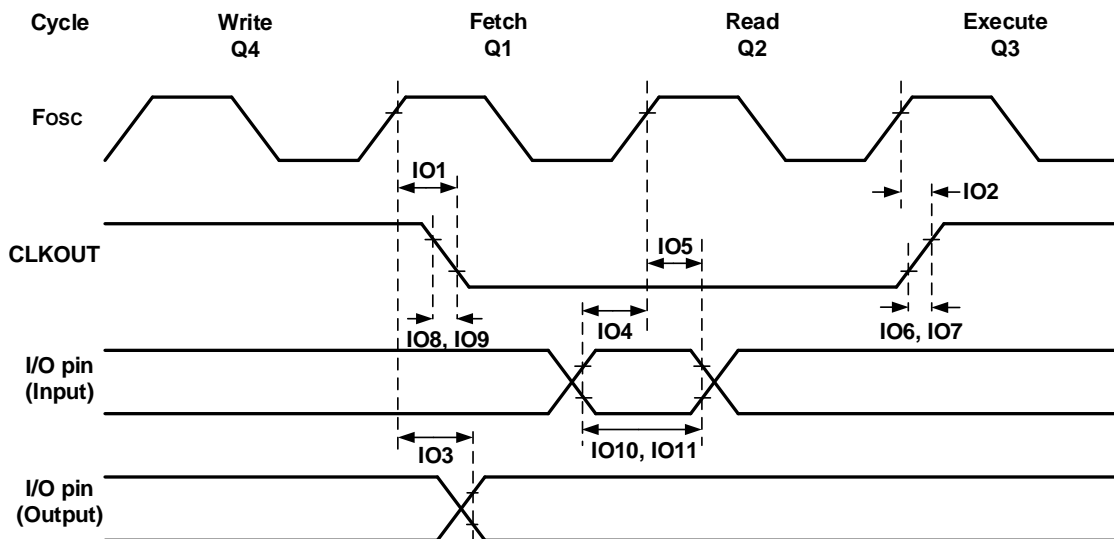

Table 43-9. I/O and CLKOUT Timing Specifications

Standard Operating Conditions (unless otherwise stated)							
Param No.	Sym.	Characteristic	Min.	Typ. †	Max.	Units	Conditions
IO1*	T _{CLKOUTH}	CLKOUT rising edge delay (rising edge F _{OSC} (Q1 cycle) to falling edge CLKOUT)	—	—	70	ns	
IO2*	T _{CLKOUTL}	CLKOUT falling edge delay (rising edge F _{OSC} (Q3 cycle) to rising edge CLKOUT)	—	—	72	ns	
IO3*	T _{IO_VALID}	Port output valid time (rising edge F _{OSC} (Q1 cycle) to port valid)	—	50	70	ns	
IO4*	T _{IO_SETUP}	Port input setup time (Setup time before rising edge F _{OSC} - Q2 cycle)	20	—	—	ns	
IO5*	T _{IO_HOLD}	Port input hold time (Hold time after rising edge F _{OSC} - Q2 cycle)	50	—	—	ns	
IO6*	T _{IOR_SLREN}	Port I/O rise time, slew rate enabled	—	25	—	ns	V _{DD} = 3.0V
IO7*	T _{IOR_SLRDIS}	Port I/O rise time, slew rate disabled	—	5	—	ns	V _{DD} = 3.0V
IO8*	T _{IOF_SLREN}	Port I/O fall time, slew rate enabled	—	25	—	ns	V _{DD} = 3.0V
IO9*	T _{IOF_SLRDIS}	Port I/O fall time, slew rate disabled	—	5	—	ns	V _{DD} = 3.0V
IO10*	T _{INT}	INT pin high or low time to trigger an interrupt	25	—	—	ns	
IO11*	T _{IOC}	Interrupt-on-Change minimum high or low time to trigger interrupt	25	—	—	ns	

* These parameters are characterized but not tested.

43.4.4 Reset, WDT, Power-up Timer, and Brown-Out Reset Specifications

Figure 43-7. Reset, Watchdog Timer, and Power-up Timer Timing

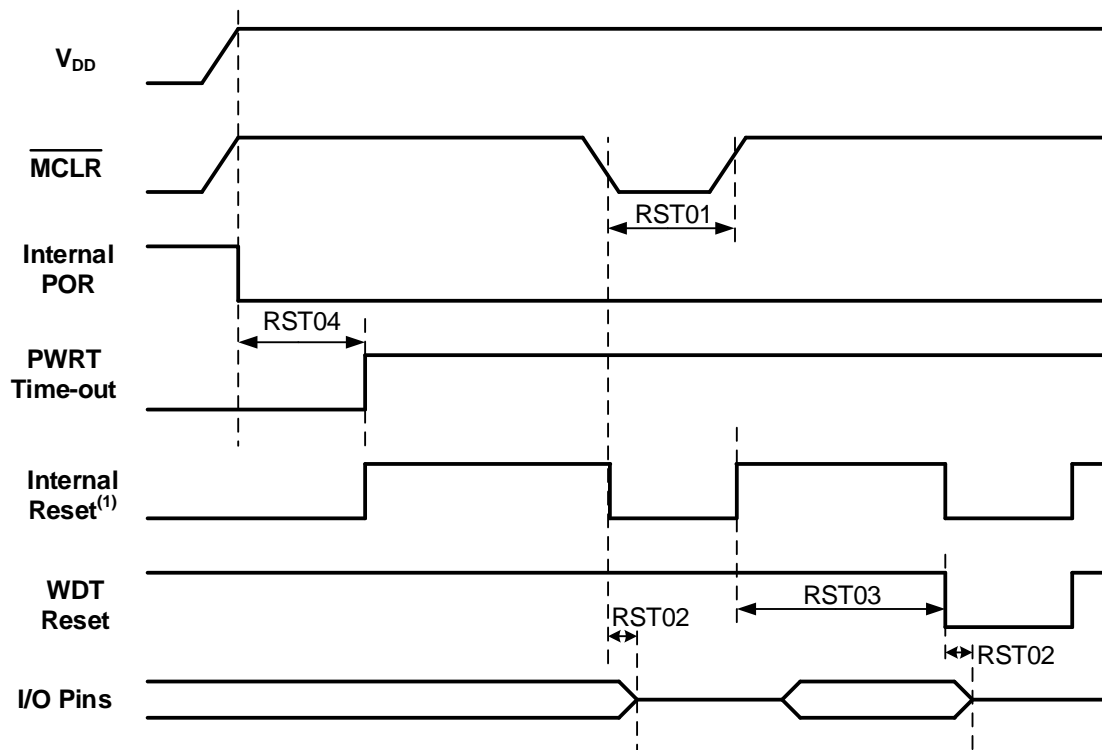

Note:

1. Asserted low.

Figure 43-8. Brown-out Reset Timing and Characteristics

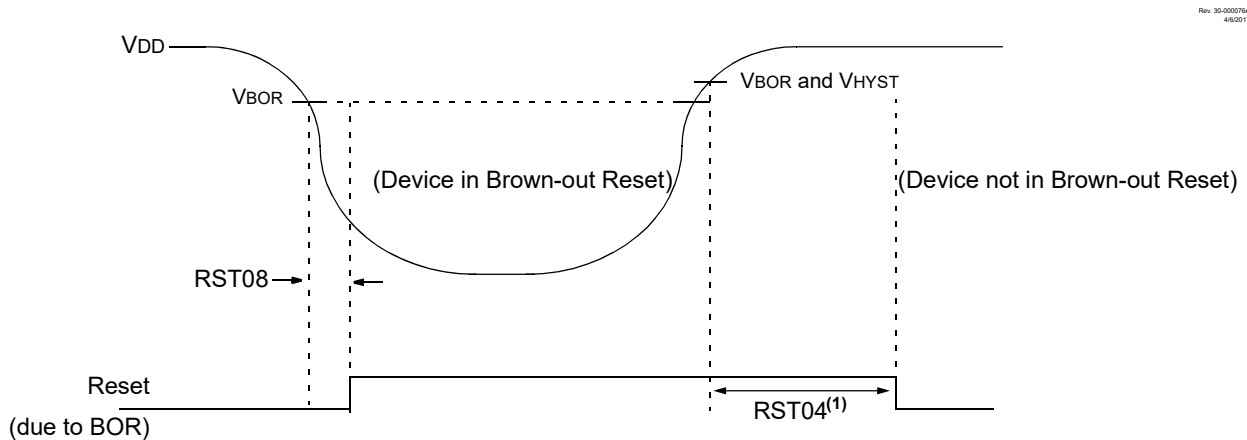

Note:

1. Only if $\overline{\text{PWRTE}}$ bit in the Configuration Word register is programmed to '1'; 2 ms delay if $\overline{\text{PWRTE}} = 0$.

Table 43-10.

Standard Operating Conditions (unless otherwise stated)

Param No.	Sym.	Characteristic	Min.	Typ. †	Max.	Units	Conditions
RST01*	T_{MCLR}	MCLR Pulse-Width Low to ensure Reset	—	—	—	μs	
RST02*	T_{IOZ}	I/O high-impedance from Reset detection	—	—	2	μs	
RST03	T_{WDT}	Watchdog Timer Time-out Period	—	16	—	ms	WDTCPS = 00100
RST04*	T_{PWRT}	Power-up Timer Period	—	65	—	ms	
RST05	T_{OST}	Oscillator Start-up Timer Period ^(1,2)	—	1024	—	T_{OSC}	
RST06	V_{BOR}	Brown-out Reset Voltage	—	2.65	—	V	BORV = 0
			—	1.9	—	V	BORV = 1
RST07	V_{BORHYS}	Brown-out Reset Hysteresis	—	60	—	mV	BORV = 0
RST08	T_{BORDC}	Brown-out Reset Response Time	—	3	—	μs	
RST09	V_{LPBOR}	Low-Power Brown-out Reset Voltage	1.8	1.9	2.2	V	

* These parameters are characterized but not tested.

† Data in "Typ" column is at 3.0V, 25°C unless otherwise stated. These parameters are for design guidance only and are not tested.

Notes:

1. By design, the Oscillator Start-up Timer (OST) counts the first 1024 cycles, independent of frequency.
2. To ensure these voltage tolerances, V_{DD} and V_{SS} must be capacitively decoupled as close to the device as possible. 0.1 μF and 0.01 μF values in parallel are recommended.

43.4.5 Analog-to-Digital Converter (ADC) Accuracy Specifications⁽¹⁾

Table 43-11.

Standard Operating Conditions (unless otherwise stated)							
$V_{DD} = 3.0V$, $T_A = 25^\circ C$, $T_{AD} = 1 \mu s$, $F_{OSC} \leq 8 MHz$, $ADC_{VREF} = V_{DD}/V_{SS}$, Differential Mode							
Param No.	Sym.	Characteristic	Min.	Typ. †	Max.	Units	Conditions
AD01	N_R	Resolution	—	—	12	bit	
AD02*	E_{IL}	Integral Nonlinearity Error	-6	± 0.5	+6	LSb	$ADC_{REF+} = 3.0V$, $ADC_{REF-} = 0V$
AD03*	E_{DL}	Differential Nonlinearity Error	-1	± 0.5	+2.5	LSb	$ADC_{REF+} = 3.0V$, $ADC_{REF-} = 0V$
AD04*	E_{OFF}	Offset Error	-11.5	± 3	+11.5	LSb	$ADC_{REF+} = 3.0V$, $ADC_{REF-} = 0V$
AD05*	E_{GN}	Gain Error	-4	± 1	+4	LSb	$ADC_{REF+} = 3.0V$, $ADC_{REF-} = 0V$
AD06	V_{ADREF}	ADC Reference Voltage ($AD_{REF+} - AD_{REF-}$)	1.8	—	V_{DD}	V	
AD07	V_{AIN}	Full-Scale Range	V_{SS}	—	AD_{REF+}	V	
AD08	Z_{AIN}	Recommended Impedance of Analog Voltage Source	—	1	—	k Ω	
AD09	R_{VREF}	ADC Voltage Reference Ladder Impedance	—	50	—	k Ω	(Note 2)

* These parameters are characterized but not tested.
† Data in "Typ" column is at 3.0V, 25°C unless otherwise stated. These parameters are for design guidance only and are not tested.

Notes:

- Total Absolute Error is the sum of the offset, gain and integral nonlinearity (INL) errors.
- This is the impedance seen by the V_{REF} pads when the external reference pads are selected.

43.4.6 Analog-to-Digital Converter (ADC) Conversion Timing Specifications

Table 43-12.

Standard Operating Conditions (unless otherwise stated)							
Param No.	Sym.	Characteristic	Min.	Typ. †	Max.	Units	Conditions
AD20	T_{AD}	ADC Clock Period	0.5	—	9	μs	Using F_{OSC} as the ADC clock source $ADOCS = 0$
			—	2	—	μs	Using ADCRC as the ADC clock source $ADOCS = 1$
AD21	T_{CNV}	Conversion Time	—	$14 T_{AD} + 2T_{CY}$	—	—	Using F_{OSC} as the ADC clock source $ADOCS = 0$
			—	$16 T_{AD} + 2T_{CY}$	—	—	Using ADCRC as the ADC clock source $ADOCS = 1$
AD22	T_{HCD}	Sample-and-Hold Capacitor Disconnect Time	—	$2 T_{AD} + 1T_{CY}$	—	—	Using F_{OSC} as the ADC clock source $ADOCS = 0$
			—	$3 T_{AD} + 2T_{CY}$	—	—	Using ADCRC as the ADC clock source $ADOCS = 1$

* These parameters are characterized but not tested.
† Data in "Typ" column is at 3.0V, 25°C unless otherwise stated. These parameters are for design guidance only and are not tested.

Figure 43-9. ADC Conversion Timing (ADC Clock F_{OSC} -Based)

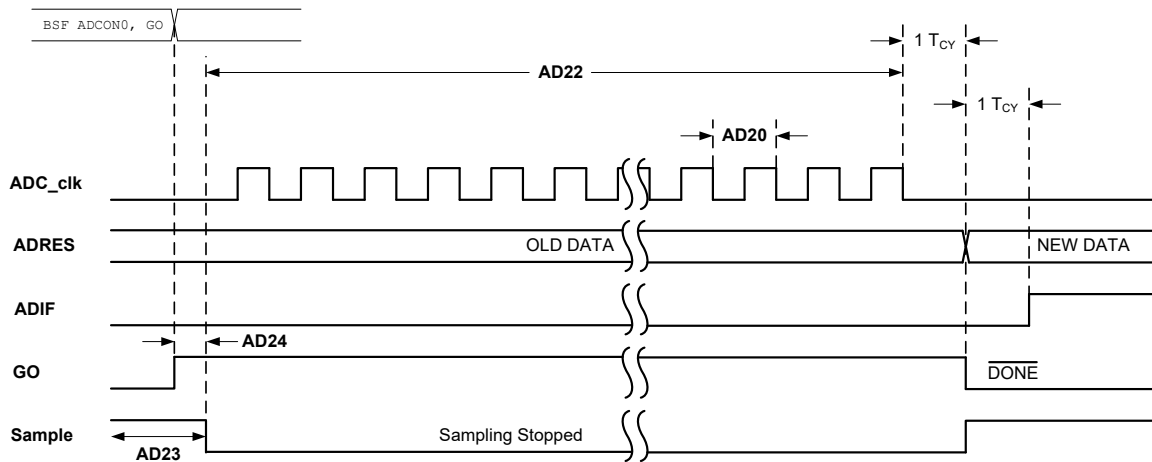
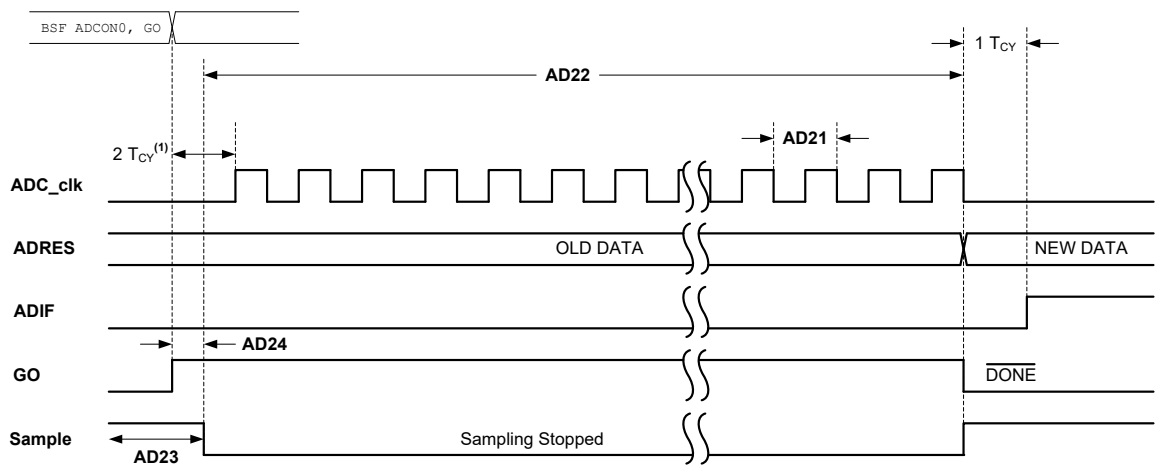

Figure 43-10. ADC Conversion Timing (ADC Clock from ADCRC)



Note:

1. If the ADC clock source is selected as ADCRC, a time of T_{CY} is added before the ADC clock starts. This allows the `SLEEP` instruction to be executed.

43.4.7 8-Bit DAC Specifications

Table 43-13.

Standard Operating Conditions (unless otherwise stated)							
$V_{DD} = 3.0V, T_A = 25^\circ C$							
Param No.	Sym.	Characteristic	Min.	Typ. †	Max.	Units	Conditions
DAC01*	C_{LSB}	Step Size	—	$(V_{DACREF+} - V_{DACREF-})/256$	—	V	
DAC02	C_{INL}	Integral Error	—	—	±1.4	LSb	
DAC03	C_{DNL}	Differential Error	—	—	±1	LSb	
DAC04	C_{OFF}	Offset Error	—	—	±1	LSb	
DSB05	C_{GN}	Gain Error	—	—	±1.5	LSb	
DSB06*	C_R	Unit Resistor Value	—	—	—	kΩ	
DSB07*	C_{ST}	Settling Time ⁽¹⁾	—	—	10	μs	
DSB08*	C_{ACC}	Absolute Accuracy	—	—	±4	LSb	

* These parameters are characterized but not tested.
† Data in “Typ” column is at 3.0V, 25°C unless otherwise stated. These parameters are for design guidance only and are not tested.
Note:
1. Settling time measured while DACR[7:0] transitions from ‘b00000000 to ‘b11111111.

43.4.8 Comparator Specifications

Table 43-14.

Standard Operating Conditions (unless otherwise stated)							
$V_{DD} = 3.0V, T_A = 25^\circ C$							
Param No.	Sym.	Characteristic	Min.	Typ. †	Max.	Units	Conditions
CM01	V_{IOFF}	Input Offset Voltage	—	—	±50	mV	$V_{ICM} = V_{DD}/2$
CM02	V_{ICM}	Input Common-Mode Range	GND	—	V_{DD}	V	
CM03	CMRR	Common-Mode Input Rejection Ratio	—	50	—	dB	
CM04	V_{HYST}	Comparator Hysteresis	10	25	45	mV	
CM05	$T_{RESP}^{(1)}$	Response Time, Rising Edge	—	300	600	ns	
		Response Time, Falling Edge	—	220	500	ns	

* These parameters are characterized but not tested.
† Data in “Typ” column is at 3.0V, 25°C unless otherwise stated. These parameters are for design guidance only and are not tested.
Note:
1. Response time measured with one comparator input at $V_{DD}/2$, while the other input transitions from V_{SS} to V_{DD} .

43.4.9 Zero-Cross Detect (ZCD) Specifications

Table 43-15.

Standard Operating Conditions (unless otherwise stated)							
$V_{DD} = 3.0V, T_A = 25^\circ C$							
Param No.	Sym.	Characteristic	Min.	Typ. †	Max.	Units	Conditions
ZC01	V_{PINZC}	Voltage on Zero-Cross Pin	—	0.9	—	V	
ZC02	I_{ZCD_MAX}	Maximum source or sink current	—	—	600	μA	

.....continued

Standard Operating Conditions (unless otherwise stated)							
$V_{DD} = 3.0V, T_A = 25^\circ C$							
Param No.	Sym.	Characteristic	Min.	Typ. †	Max.	Units	Conditions
ZC03	T _{RESPH}	Response Time, Rising Edge	—	1	—	µs	
	T _{RESPL}	Response Time, Falling Edge	—	1	—	µs	

† Data in “Typ” column is at 3.0V, 25°C unless otherwise stated. These parameters are for design guidance only and are not tested.

43.4.10 Fixed Voltage Reference (FVR) Specifications

Table 43-16.

Standard Operating Conditions (unless otherwise stated)							
Param No.	Sym.	Characteristic	Min.	Typ. †	Max.	Units	Conditions
FVR01	V _{FVR1}	1x Gain (1.024V)	-4	—	-4	%	$V_{DD} \geq 2.5V, -40^\circ C$ to $85^\circ C$
FVR02	V _{FVR2}	2x Gain (2.048V)	-4	—	+4	%	$V_{DD} \geq 2.5V, -40^\circ C$ to $85^\circ C$
FVR03	V _{FVR4}	4x Gain (4.096V)	-5	—	+5	%	$V_{DD} \geq 4.75V, -40^\circ C$ to $85^\circ C$
FVR04	T _{FVRST}	FVR Start-up Time	—	25	—	µs	

43.4.11 Temperature Indicator Requirements

Table 43-17.

Standard Operating Conditions (unless otherwise stated)								
Param No.	Sym.	Characteristic	Min.	Typ. †	Max.	Units	Conditions	
TS01*	T _{ACQMIN}	Minimum ADC Acquisition Time Delay	—	25	—	µs		
TS02*	M _V	Voltage Sensitivity	High Range	—	-3.75	—	mV/°C	TSRNG = 1
			Low Range	—	-2.75	—	mV/°C	TSRNG = 0

* These parameters are characterized but not tested.
† Data in “Typ” column is at 3.0V, 25°C unless otherwise stated. These parameters are for design guidance only and are not tested.

43.4.12 Timer0 and Timer1 External Clock Requirements

Table 43-18.

Standard Operating Conditions (unless otherwise stated)							
Operating Temperature: $-40^\circ C \leq T_A \leq +125^\circ C$							
Param No.	Sym.	Characteristic	Min.	Typ. †	Max.	Units	Conditions
40*	T _{T0H}	T0CKI High Pulse-Width	No Prescaler	$0.5T_{CY}+20$	—	—	ns
			With Prescaler	10	—	—	ns
41*	T _{T0L}	T0CKI Low Pulse-Width	No Prescaler	$0.5T_{CY}+20$	—	—	ns
			With Prescaler	10	—	—	ns
42*	T _{T0P}	T0CKI Period	Greater of: 20 or $(T_{CY}+40)/N$		—	—	ns N = Prescale value
45*	T _{T1H}	T1CKI High Time	Synchronous, No Prescaler	$0.5T_{CY}+20$	—	—	ns
			Synchronous, with Prescaler	15	—	—	ns
			Asynchronous	30	—	—	ns

.....continued

Standard Operating Conditions (unless otherwise stated)								
Operating Temperature: $-40^{\circ}\text{C} \leq T_A \leq +125^{\circ}\text{C}$								
Param No.	Sym.	Characteristic		Min.	Typ. †	Max.	Units	Conditions
46*	T _{T1L}	T1CKI Low Time	Synchronous, No Prescaler	$0.5T_{CY}+20$	—	—	ns	
			Synchronous, with Prescaler	15	—	—	ns	
			Asynchronous	30	—	—	ns	
47*	T _{T1P}	T1CKI Input Period	Synchronous	Greater of: 30 or $(T_{CY}+40)/N$	—	—	ns	N = Prescale value
			Asynchronous	60	—	—	ns	
49*	TCKEZ _{TMR1}	Delay from External Clock Edge to Timer Increment		$2 T_{OSC}$	—	$7 T_{OSC}$	—	Timers in Sync mode

* These parameters are characterized but not tested.
† Data in "Typ" column is at 3.0V, 25°C unless otherwise stated. These parameters are for design guidance only and are not tested.

Figure 43-11. Timer0 and Timing1 External Clock Timings

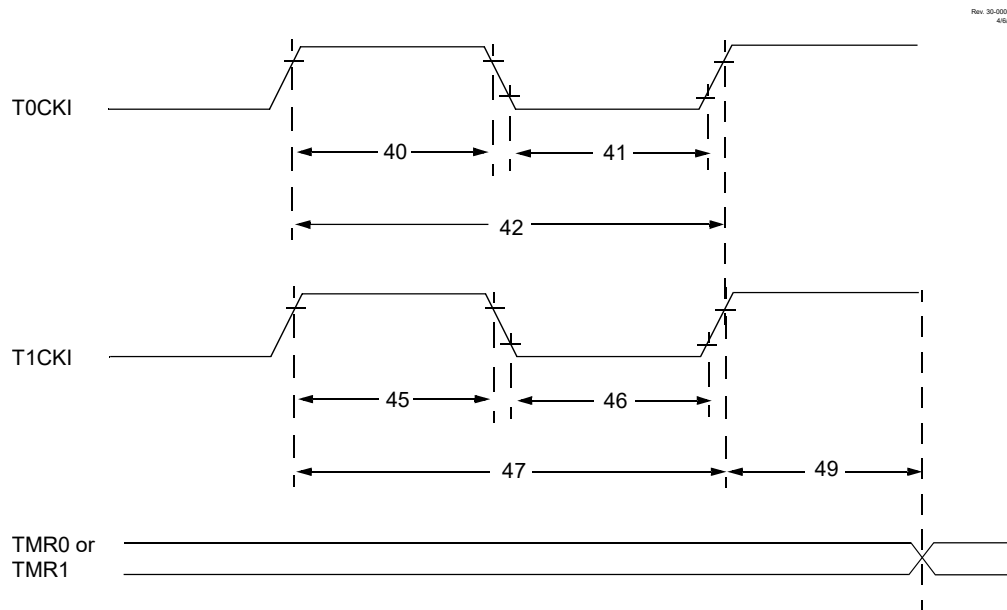

43.4.13 Capture/Compare/PWM Requirements (CCP)

Table 43-19.

Standard Operating Conditions (unless otherwise stated)								
Operating Temperature: $-40^{\circ}\text{C} \leq T_A \leq +125^{\circ}\text{C}$								
Param No.	Sym.	Characteristic		Min.	Typ. †	Max.	Units	Conditions
CC01*	T _{CCL}	CCPx Input Low Time	No Prescaler	$0.5T_{CY}+20$	—	—	ns	
			With Prescaler	20	—	—	ns	
CC02*	T _{CCH}	CCPx Input High Time	No Prescaler	$0.5T_{CY}+20$	—	—	ns	
			With Prescaler	20	—	—	ns	
CC03*	T _{CCP}	CCPx Input Period		$(3T_{CY}+40)/N$	—	—	ns	N = Prescale value

.....continued

Standard Operating Conditions (unless otherwise stated)
Operating Temperature: $-40^{\circ}\text{C} \leq T_A \leq +125^{\circ}\text{C}$

Param No.	Sym.	Characteristic	Min.	Typ. †	Max.	Units	Conditions
-----------	------	----------------	------	--------	------	-------	------------

* These parameters are characterized but not tested.
† Data in "Typ" column is at 3.0V, 25°C unless otherwise stated. These parameters are for design guidance only and are not tested.

Figure 43-12. Capture/Compare/PWM Timings (CCP)

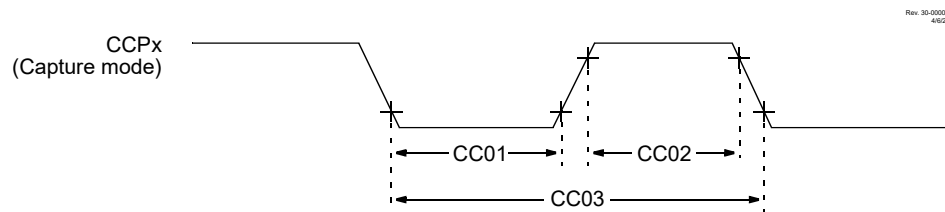

Note: Refer to [Figure 43-3](#) for load conditions.

43.4.14 EUSART Synchronous Transmission Requirements

Table 43-20.

Standard Operating Conditions (unless otherwise stated)						
Param No.	Sym.	Characteristic	Min.	Max.	Units	Conditions
US120	$T_{CKH2DTV}$	SYNC XMIT (Host and Client)	—	—	ns	$3.0\text{V} \leq V_{DD} \leq 5.5\text{V}$
		Clock high to data-out valid	—	—	ns	$1.8\text{V} \leq V_{DD} \leq 5.5\text{V}$
US121	T_{CKRF}	Clock out rise time and fall time (Host mode)	—	—	ns	$3.0\text{V} \leq V_{DD} \leq 5.5\text{V}$
			—	—	ns	$1.8\text{V} \leq V_{DD} \leq 5.5\text{V}$
US122	T_{DTRF}	Data-out rise time and fall time	—	—	ns	$3.0\text{V} \leq V_{DD} \leq 5.5\text{V}$
			—	—	ns	$1.8\text{V} \leq V_{DD} \leq 5.5\text{V}$

Figure 43-13. EUSART Synchronous Transmission (Host/Client) Timing

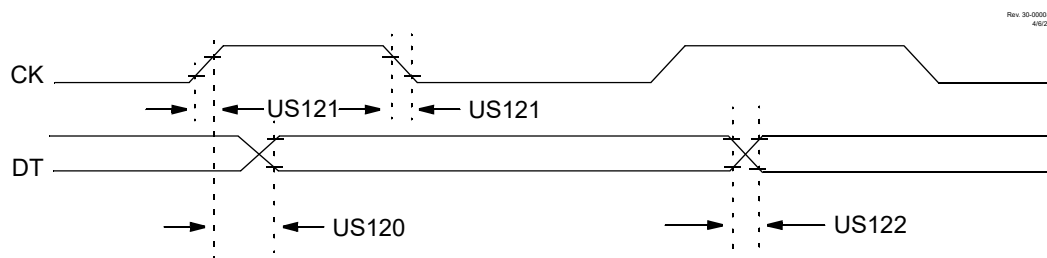

Note: Refer to [Figure 43-3](#) for load conditions.

43.4.15 EUSART Synchronous Receive Requirements

Table 43-21.

Standard Operating Conditions (unless otherwise stated)						
Param No.	Sym.	Characteristic	Min.	Max.	Units	Conditions
US125	$T_{DTV2CKL}$	SYNC RCV (Host and Client) Data-setup before CK ↓ (DT hold time)	—	—	ns	
US126	$T_{CKL2DTL}$	Data-hold after CK ↓ (DT hold time)	—	—	ns	

Figure 43-14. EUSART Synchronous Receive (Host/Client) Timing

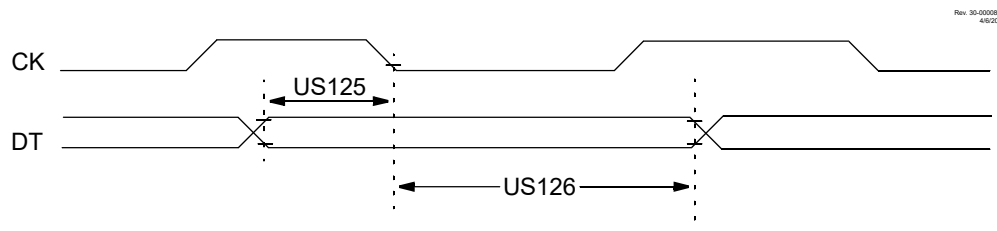

Note: Refer to Figure 43-3 for load conditions.

43.4.16 SPI Mode Requirements

Table 43-22. SPI Mode

Standard Operating Conditions (unless otherwise stated)							
Param No.	Sym.	Characteristic	Min.	Typ. †	Max.	Units	Conditions
SP70*	$T_{SSL2SCKH}$, $T_{SSL2SCKL}$	SDO to SCK↓ or SCK↑ input	$2.25 \cdot T_{CY}$	—	—	ns	
SP71*	T_{SCKH}	SCK output high time	$T_{CY} + 20$	—	$0.5 T_{SCK} + 12$	ns	
SP72*	T_{SCKL}	SCK output low time	$T_{CY} + 20$	—	$0.5 T_{SCK} + 12$	ns	
SP73*	$T_{D1V2SCKH}$, $T_{D1V2SCKL}$	Setup time of SDI data input to SCK edge	85	—	—	ns	
SP74*	$T_{SCK2D1L}$, $T_{SCK2D1L}$	Hold time of SDI data input to SCK edge	0	—	—	ns	
		Hold time of SDI data input to final SCK	$0.5 T_{SCK}$	—	—	ns	CKE = 0, SMP = 1
SP75*	$T_{DO\uparrow}$	SDO data output rise time	—	10	25	ns	$C_L = 50$ pF
SP76*	$T_{DO\downarrow}$	SDO data output fall time	—	10	25	ns	$C_L = 50$ pF
SP78*	$T_{SCK\uparrow}$	SCK output rise time	—	10	25	ns	$C_L = 50$ pF
SP79*	$T_{SCK\downarrow}$	SCK output fall time	—	10	25	ns	$C_L = 50$ pF
SP80*	$T_{SCK2DOV}$, $T_{SCK2DOV}$	SDO data output valid after SCK edge	—	—	—	ns	$C_L = 50$ pF
SP81*	$T_{DOV2SCKH}$, $T_{DOV2SCKL}$	SDO data output valid to first SCK edge	$1 T_{CY}$	—	—	ns	$C_L = 50$ pF CKE = 1
SP82*	$T_{SSL2DOV}$	SDO data output valid after $\overline{SS}\downarrow$ edge	—	—	50	ns	$C_L = 20$ pF
SP83*	$T_{SCK2SSH}$, $T_{SCK2SSH}$	$\overline{SS}\uparrow$ after last SCK edge	$1.5 T_{CY} + 40$	—	—	ns	

* These parameters are characterized but not tested.

† Data in “Typ” column is at 3.0V, 25°C unless otherwise stated. These parameters are for design guidance only and are not tested.

Note:

1. The SMP bit in the SSPxSTAT register must be set and the slew rate control must be disabled on the clock and data pins (clear the corresponding bits in SLRCONx register) for SPI to operate over 4 MHz.

Figure 43-15. SPI Host Mode Timing (CKE = 0, SMP = 0)

Rev. 30-000083A
4/6/2017

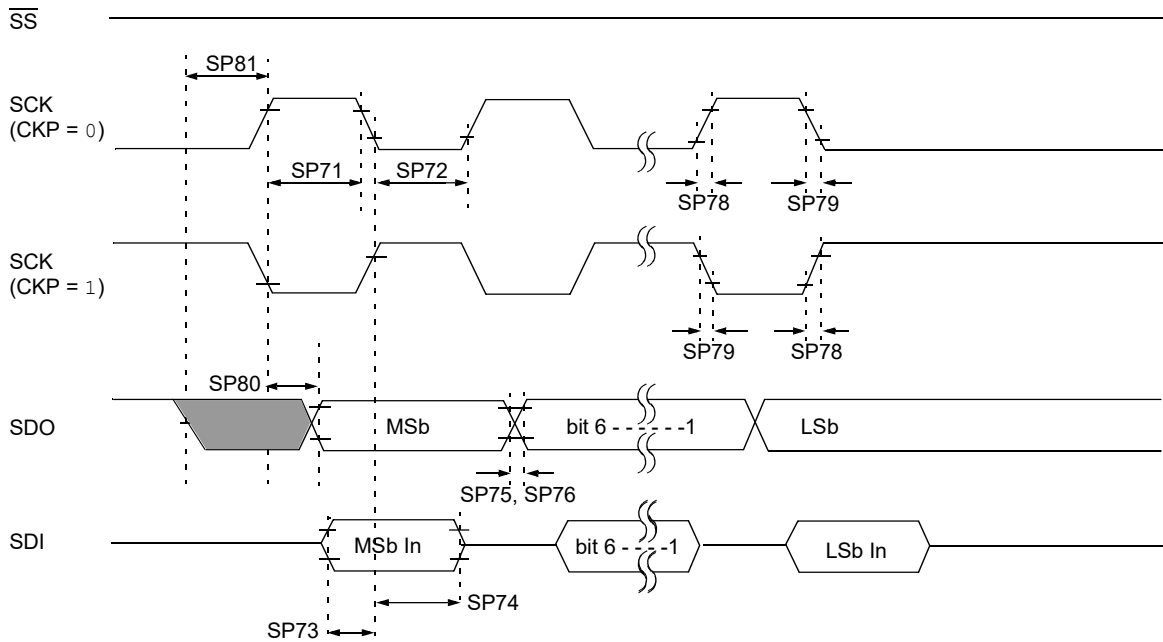

Note: Refer to Figure 43-3 for load conditions.

Figure 43-16. SPI Host Mode Timing (CKE = 1, SMP = 1)

Rev. 30-000084A
4/6/2017

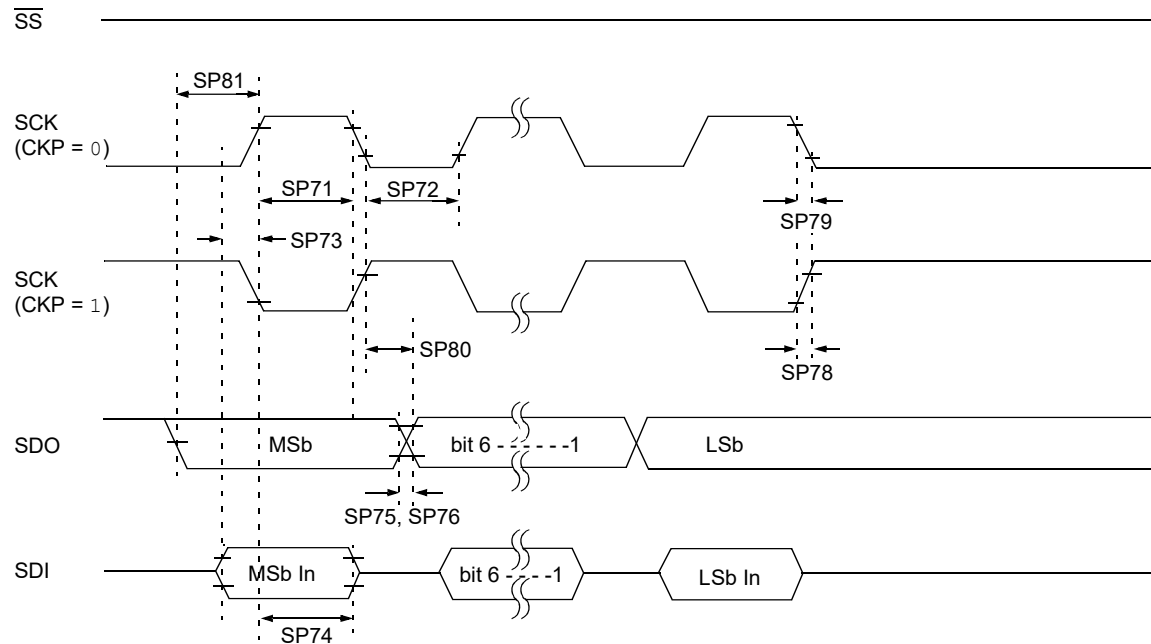

Note: Refer to Figure 43-3 for load conditions.

Figure 43-17. SPI Client Mode Timing (CKE = 0)

Rev. 30-000085A
48/0217

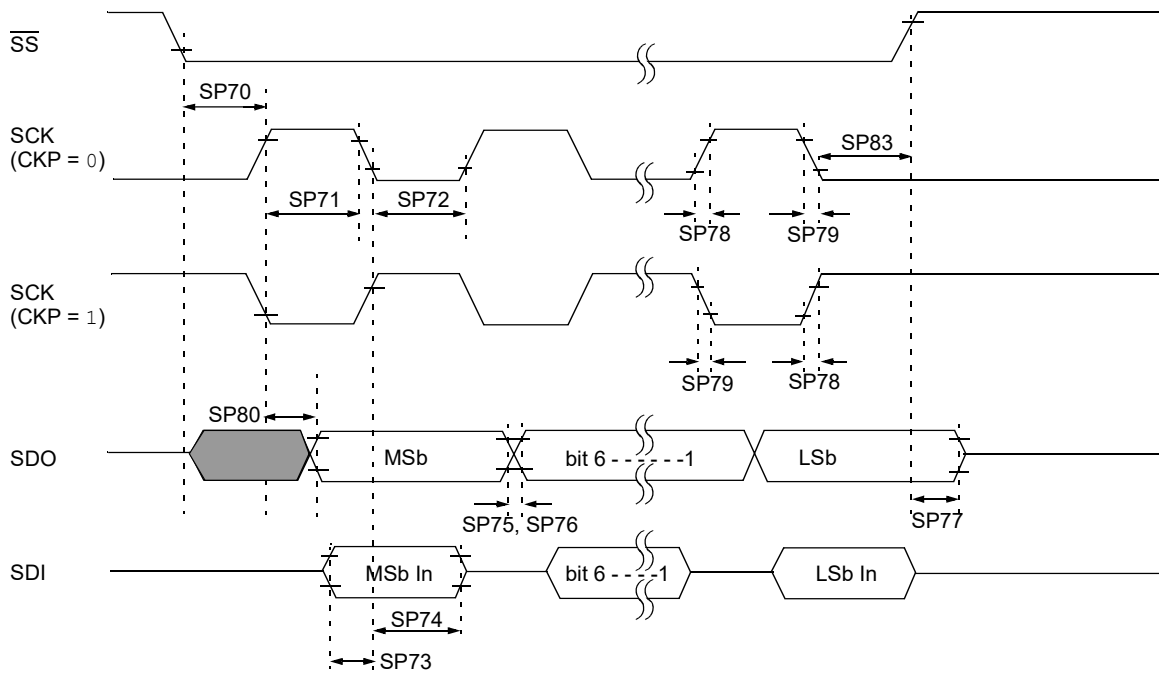

Note: Refer to Figure 43-3 for load conditions.

Figure 43-18. SPI Client Mode Timing (CKE = 1)

Rev. 30-000085A
48/0217

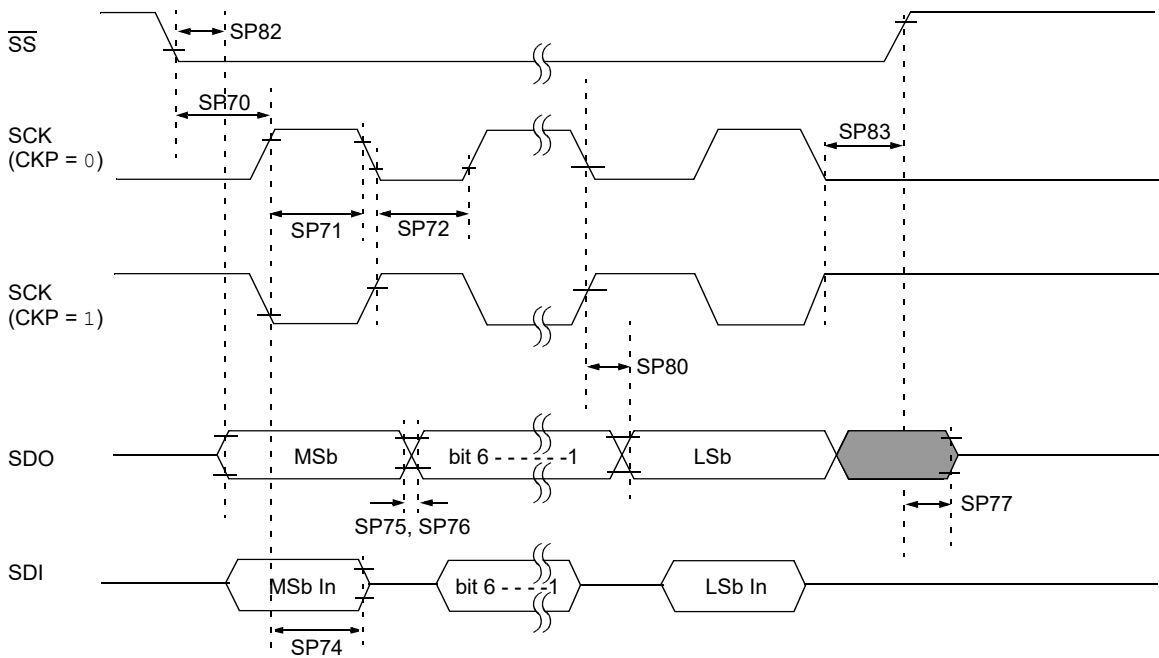

Note: Refer to Figure 43-3 for load conditions.

43.4.17 I²C Bus Start/Stop Bits Requirements

Table 43-23.

Standard Operating Conditions (unless otherwise stated)								
Param. No.	Sym.	Characteristic	Min.	Typ. †	Max.	Units	Conditions	
SP90*	T _{SU:STA}	Start condition	100 kHz mode	4700	—	—	ns	Only relevant for Repeated Start condition
		Setup time	400 kHz mode	600	—	—		
SP91*	T _{HD:STA}	Start condition	100 kHz mode	4000	—	—	ns	After this period, the first clock pulse is generated
		Hold time	400 kHz mode	600	—	—		
SP92*	T _{SU:STO}	Stop condition	100 kHz mode	4000	—	—	ns	
		Setup time	400 kHz mode	600	—	—		
SP93*	T _{HD:STO}	Stop condition	100 kHz mode	4700	—	—	ns	
		Hold time	400 kHz mode	1300	—	—		

* These parameters are characterized but not tested.

Figure 43-19. I²C Bus Start/Stop Bits Timing

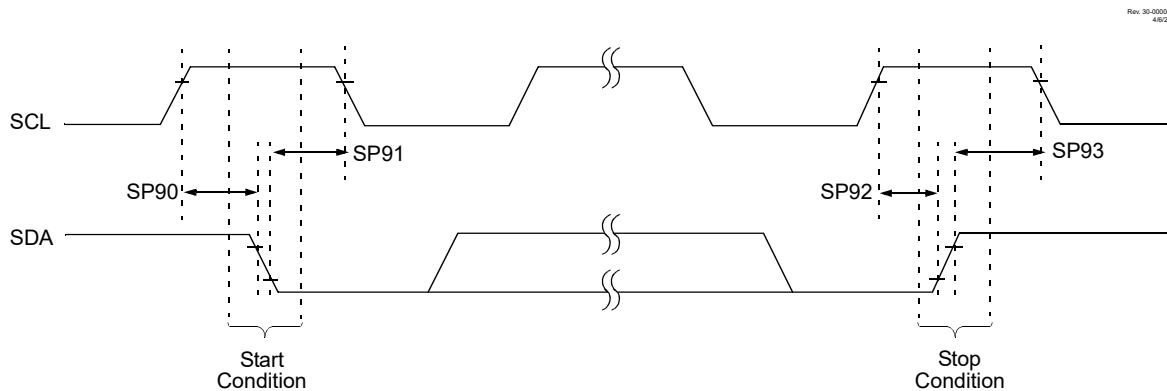

Note: Refer to Figure 43-3 for load conditions.

43.4.18 I²C Bus Data Requirements

Table 43-24.

Standard Operating Conditions (unless otherwise stated)							
Param. No.	Sym.	Characteristic	Min.	Max.	Units	Conditions	
SP100*	T _{HIGH}	Clock high time	100 kHz mode	4000	—	ns	Device must operate at a minimum of 1.5 MHz
			400 kHz mode	600	—	ns	Device must operate at a minimum of 10 MHz
SP101*	T _{LOW}	Clock low time	100 kHz mode	4700	—	ns	Device must operate at a minimum of 1.5 MHz
			400 kHz mode	1300	—	ns	Device must operate at a minimum of 10 MHz
SP102*	T _R	SDA and SCL rise time	100 kHz mode	—	1000	ns	
			400 kHz mode	20	300	ns	C _B is specified to be from 10-400 pF

.....continued

Standard Operating Conditions (unless otherwise stated)							
Param. No.	Sym.	Characteristic		Min.	Max.	Units	Conditions
SP103*	T _F	SDA and SCL fall time	100 kHz mode	—	250	ns	C _B is specified to be from 10-400 pF
			400 kHz mode	20 × (V _{DD} /5.5V)	250	ns	
SP106*	T _{HD:DAT}	Data input hold time	100 kHz mode	0	—	ns	
			400 kHz mode	0	—	ns	
SP107*	T _{SU:DAT}	Data input setup time	100 kHz mode	250	—	ns	(Note 2)
			400 kHz mode	100	—	ns	
SP109*	T _{AA}	Output valid from clock	100 kHz mode	—	3450	ns	(Note 1)
			400 kHz mode	—	900	ns	
SP110*	T _{BUF}	Bus free time	100 kHz mode	4700	—	ns	Time the bus must be free before a new transmission can start
			400 kHz mode	1300	—	ns	
SP111	C _B	Bus capacitive loading	100 kHz mode	—	400	pF	
			400 kHz mode	—	400	pF	

* These parameters are characterized but not tested.

Notes:

1. As a transmitter, the device must provide this internal minimum delay time to bridge the undefined region (min. 300 ns) of the falling edge of SCL to avoid unintended generation of Start or Stop conditions.
2. A Fast mode (400 kHz) I²C bus device can be used in a Standard mode (100 kHz) I²C bus system, but the requirement T_{SU:DAT} ≥ 250 ns must then be met. This will automatically be the case if the device does not stretch the low period of the SCL signal. If such a device does stretch the low period of the SCL signal, it must output the next data bit to the SDA line TR max. + T_{SU:DAT} = 1000 + 250 = 1250 ns (according to the Standard mode I²C bus specification), before the SCL line is released.
3. Using internal I²C pull-ups. For greater bus capacitance use external pull-ups.

Figure 43-20. I²C Bus Data Timing

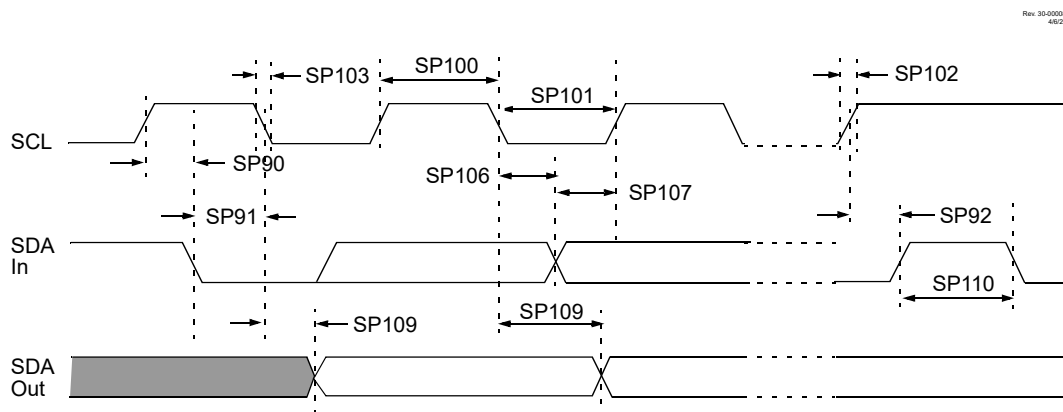

Note: Refer to [Figure 43-3](#) for load conditions.

43.4.19 Configurable Logic Cell (CLC) Characteristics

Table 43-25.

Standard Operating Conditions (unless otherwise stated)								
Operating Temperature: $-40^{\circ}\text{C} \leq T_A \leq +125^{\circ}\text{C}$								
Param No.	Sym.	Characteristic		Min.	Typ. †	Max.	Units	Conditions
CLC01*	T_{CLCIN}	CLC input time		—	7	IO5	ns	(Note 1)
CLC02*	T_{CLC}	CLC module input to output propagation time		—	24	—	ns	$V_{\text{DD}} = 1.8\text{V}$
				—	12	—	ns	$V_{\text{DD}} > 3.6\text{V}$
CLC03*	T_{CLCOUT}	CLC output time	Rise Time	—	IO6	—	—	(Note 1)
			Fall Time	—	IO8	—	—	(Note 1)
CLC04*	F_{CLCMAX}	CLC maximum switching frequency		—	—	OS20	—	

* These parameters are characterized but not tested.
† Data in "Typ" column is at 3.0V, 25°C unless otherwise stated. These parameters are for design guidance only and are not tested.

Note:
1. See the "I/O and CLKOUT Timing Specifications" section for IO5, IO6 and IO8 rise and fall times.

Figure 43-21. CLC Propagation Timing

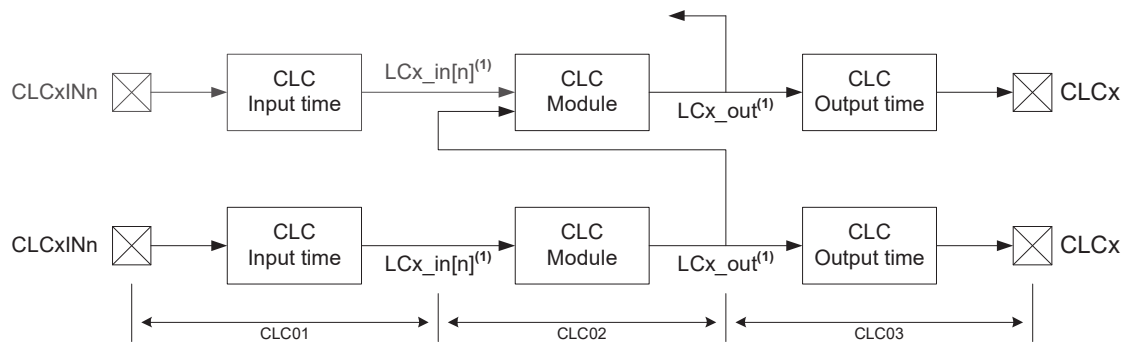

44. DC and AC Characteristics Graphs and Tables

Graphs and tables are not available at this time.

45. Packaging Information

Package Marking Information

Legend:	XX...X	Customer-specific information or Microchip part number
	Y	Year code (last digit of calendar year)
	YY	Year code (last 2 digits of calendar year)
	WW	Week code (week of January 1 is week '01')
	NNN	Alphanumeric traceability code
	(e3)	Pb-free JEDEC® designator for Matte Tin (Sn)

Note: In the event the full Microchip part number cannot be marked on one line, it will be carried over to the next line, thus limiting the number of available characters for customer-specific information.

14-Lead TSSOP (4.4 mm)

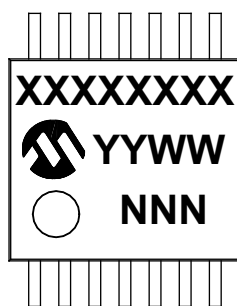

Example

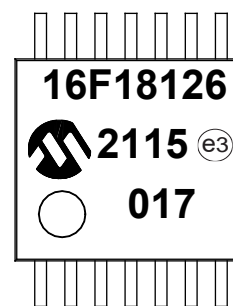

14-Lead SOIC (3.90 mm)

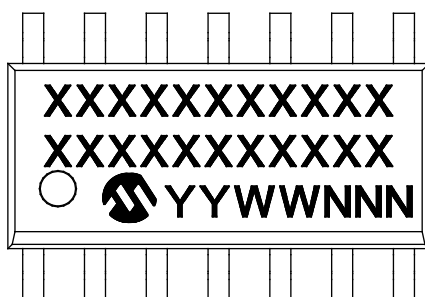

Example

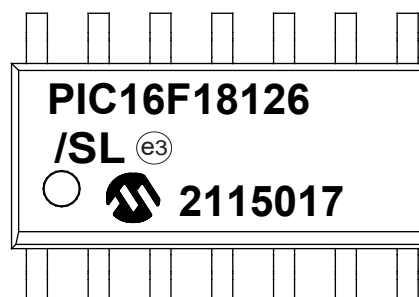

14-Lead Plastic Dual In-Line – 300 mil Body [PDIP]

14-Lead PDIP (300 mil)

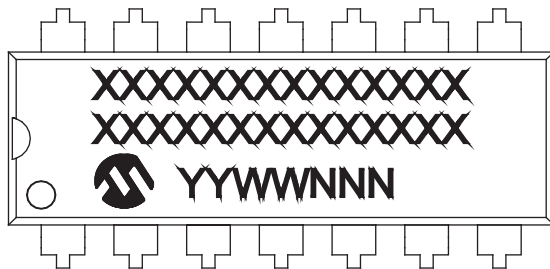

Example

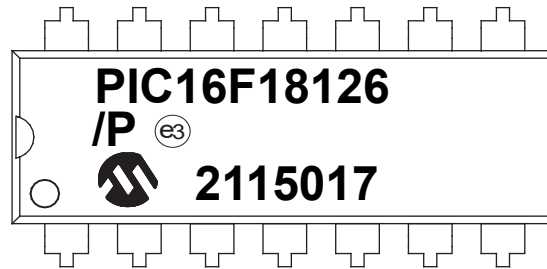

16-Lead VQFN (4x4x1 mm)

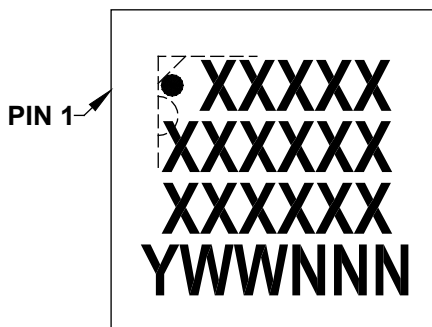

Example

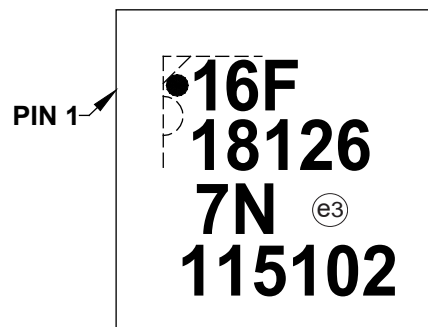

20-Lead PDIP (300 mil)

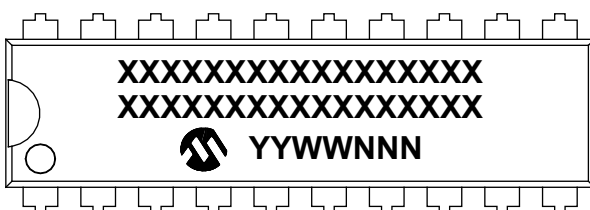

Example

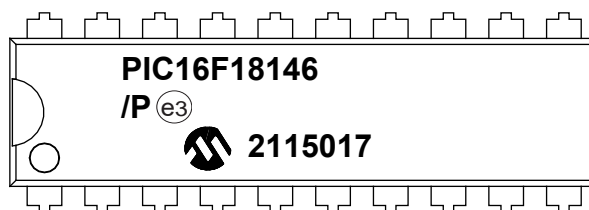

Rev. 30-099020A
10/21/2017

Rev. 35-00002B
09/12/17

20-Lead SSOP (5.30 mm)

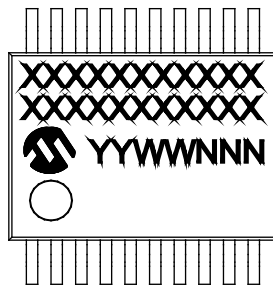

Example

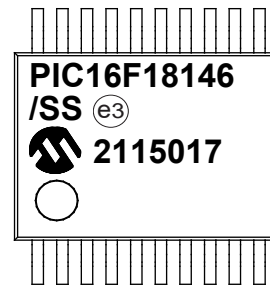

Rev. 30-00000C
09/12/17

20-Lead SOIC (7.50 mm)

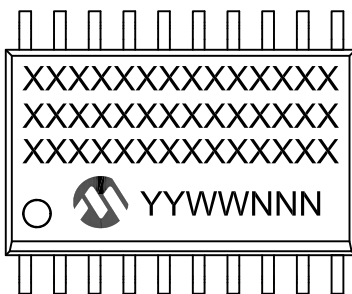

Example

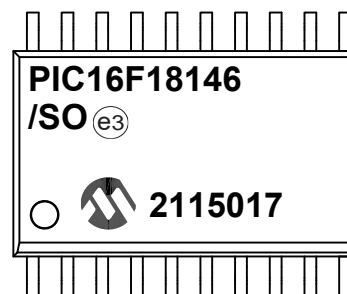

Rev. 30-00002E
12/10/2019

20-Lead VQFN (4x4x1 mm)

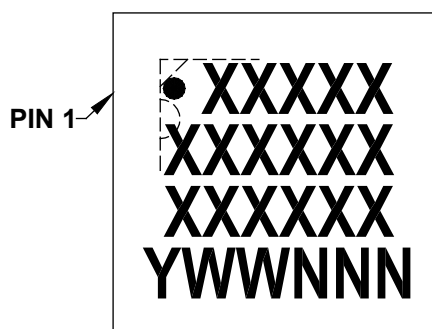

Example

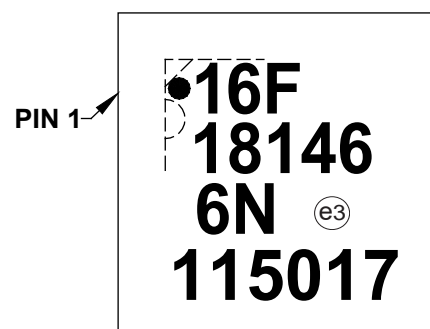

45.1 Package Details

The following sections give the technical details of the packages.

14-Lead Plastic Dual In-Line (P) – 300 mil Body [PDIP]

Note: For the most current package drawings, please see the Microchip Packaging Specification located at <http://www.microchip.com/packaging>

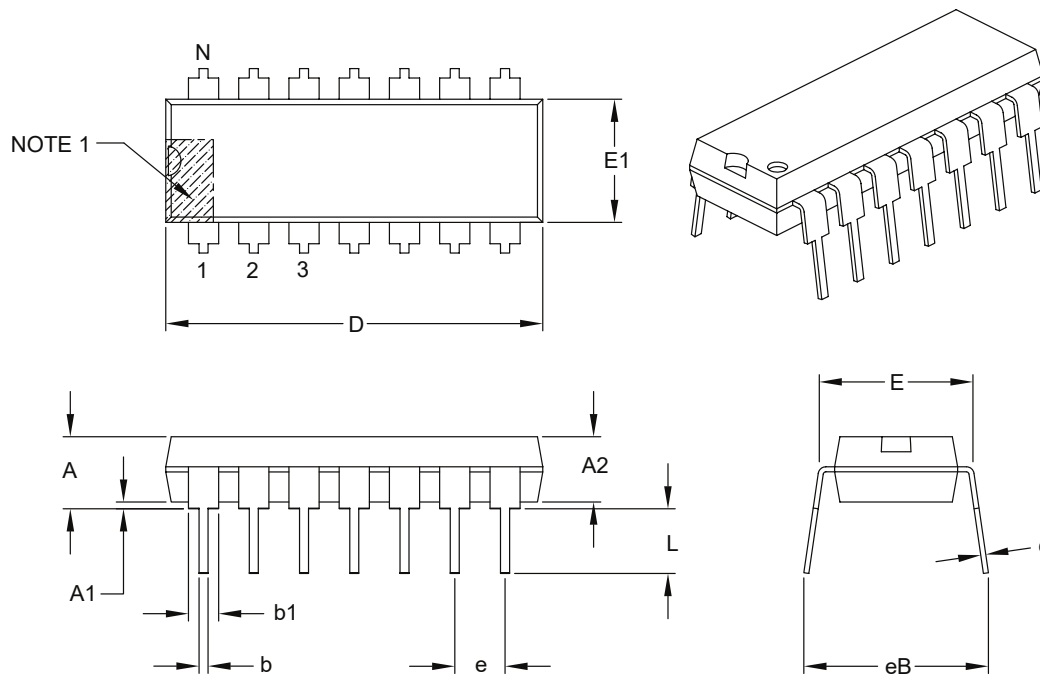

Dimension Limits	Units	INCHES		
		MIN	NOM	MAX
Number of Pins	N	14		
Pitch	e	.100 BSC		
Top to Seating Plane	A	–	–	.210
Molded Package Thickness	A2	.115	.130	.195
Base to Seating Plane	A1	.015	–	–
Shoulder to Shoulder Width	E	.290	.310	.325
Molded Package Width	E1	.240	.250	.280
Overall Length	D	.735	.750	.775
Tip to Seating Plane	L	.115	.130	.150
Lead Thickness	c	.008	.010	.015
Upper Lead Width	b1	.045	.060	.070
Lower Lead Width	b	.014	.018	.022
Overall Row Spacing §	eB	–	–	.430

Notes:

1. Pin 1 visual index feature may vary, but must be located with the hatched area.
2. § Significant Characteristic.
3. Dimensions D and E1 do not include mold flash or protrusions. Mold flash or protrusions shall not exceed .010" per side.
4. Dimensioning and tolerancing per ASME Y14.5M.

BSC: Basic Dimension. Theoretically exact value shown without tolerances.

Microchip Technology Drawing C04-005B

14-Lead Plastic Small Outline (SL) - Narrow, 3.90 mm Body [SOIC]

Note: For the most current package drawings, please see the Microchip Packaging Specification located at <http://www.microchip.com/packaging>

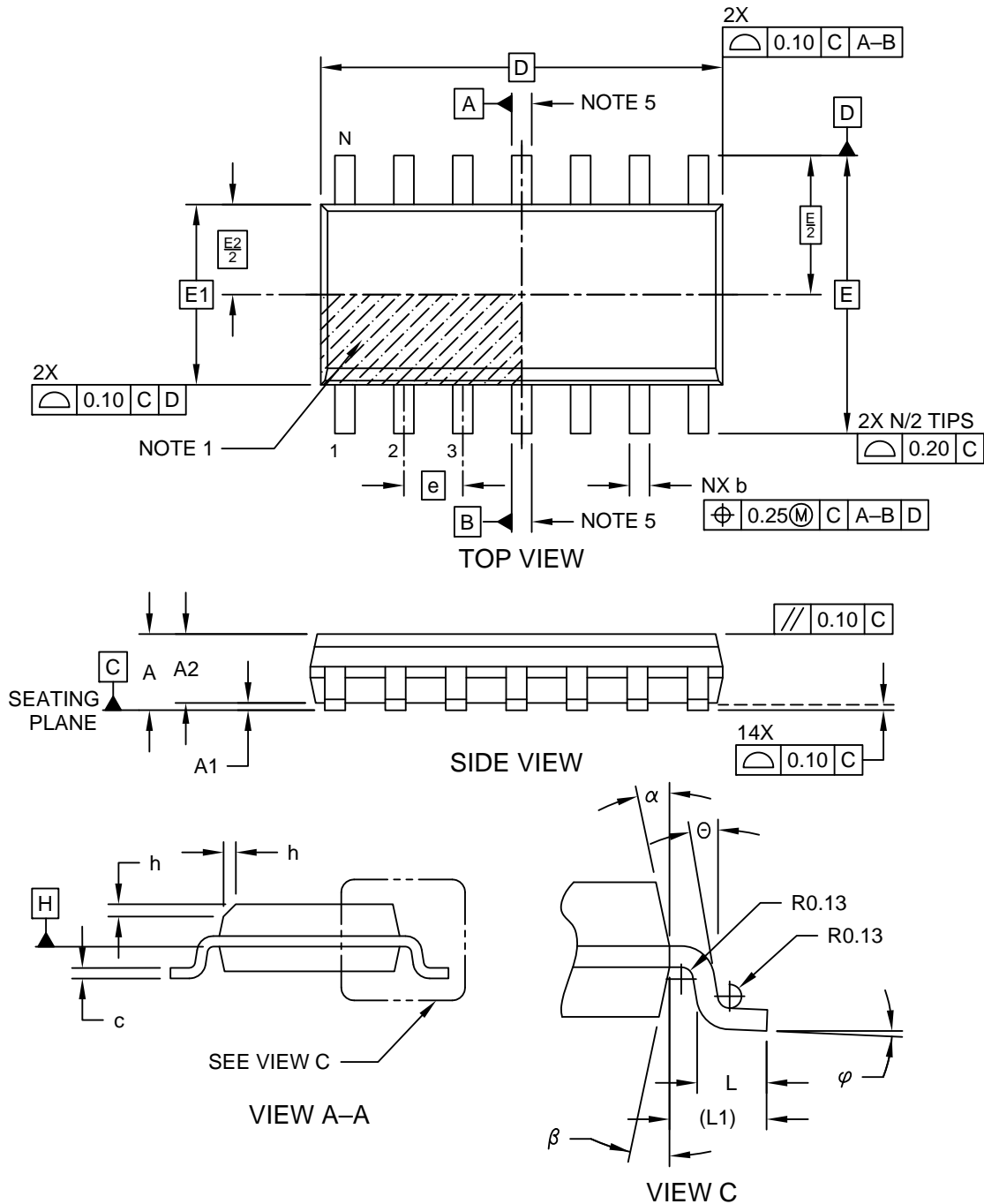

Microchip Technology Drawing No. C04-065-SL Rev D Sheet 1 of 2

14-Lead Plastic Small Outline (SL) - Narrow, 3.90 mm Body [SOIC]

Note: For the most current package drawings, please see the Microchip Packaging Specification located at <http://www.microchip.com/packaging>

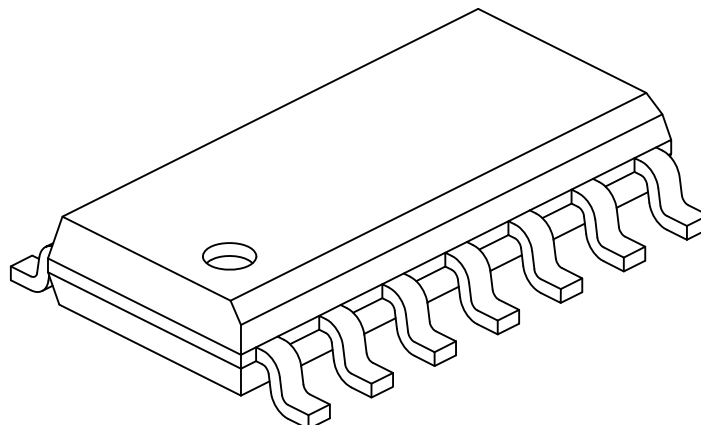

Dimension Limits	Units	MILLIMETERS		
		MIN	NOM	MAX
Number of Pins	N	14		
Pitch	e	1.27 BSC		
Overall Height	A	-	-	1.75
Molded Package Thickness	A2	1.25	-	-
Standoff §	A1	0.10	-	0.25
Overall Width	E	6.00 BSC		
Molded Package Width	E1	3.90 BSC		
Overall Length	D	8.65 BSC		
Chamfer (Optional)	h	0.25	-	0.50
Foot Length	L	0.40	-	1.27
Footprint	L1	1.04 REF		
Lead Angle	∅	0°	-	-
Foot Angle	∅	0°	-	8°
Lead Thickness	c	0.10	-	0.25
Lead Width	b	0.31	-	0.51
Mold Draft Angle Top	α	5°	-	15°
Mold Draft Angle Bottom	β	5°	-	15°

Notes:

- Pin 1 visual index feature may vary, but must be located within the hatched area.
- § Significant Characteristic
- Dimension D does not include mold flash, protrusions or gate burrs, which shall not exceed 0.15 mm per end. Dimension E1 does not include interlead flash or protrusion, which shall not exceed 0.25 mm per side.
- Dimensioning and tolerancing per ASME Y14.5M
BSC: Basic Dimension. Theoretically exact value shown without tolerances.
REF: Reference Dimension, usually without tolerance, for information purposes only.
- Datums A & B to be determined at Datum H.

Microchip Technology Drawing No. C04-065-SL Rev D Sheet 2 of 2

14-Lead Plastic Small Outline (SL) - Narrow, 3.90 mm Body [SOIC]

Note: For the most current package drawings, please see the Microchip Packaging Specification located at <http://www.microchip.com/packaging>

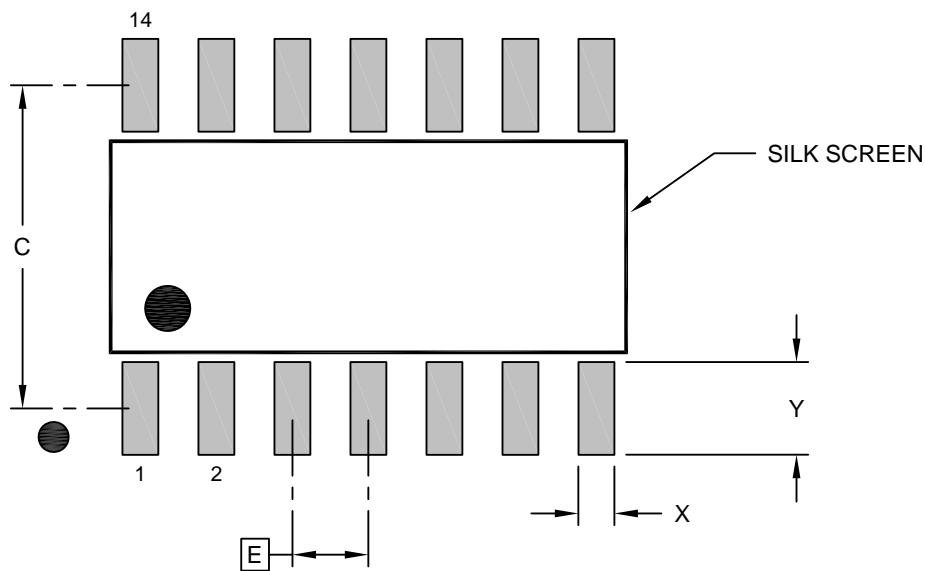

RECOMMENDED LAND PATTERN

Dimension Limits	Units	MILLIMETERS		
		MIN	NOM	MAX
Contact Pitch	E		1.27 BSC	
Contact Pad Spacing	C		5.40	
Contact Pad Width (X14)	X			0.60
Contact Pad Length (X14)	Y			1.55

Notes:

1. Dimensioning and tolerancing per ASME Y14.5M

BSC: Basic Dimension. Theoretically exact value shown without tolerances.

Microchip Technology Drawing No. C04-2065-SL Rev D

14-Lead Plastic Thin Shrink Small Outline Package [ST] - 4.4 mm Body [TSSOP]

Note: For the most current package drawings, please see the Microchip Packaging Specification located at <http://www.microchip.com/packaging>

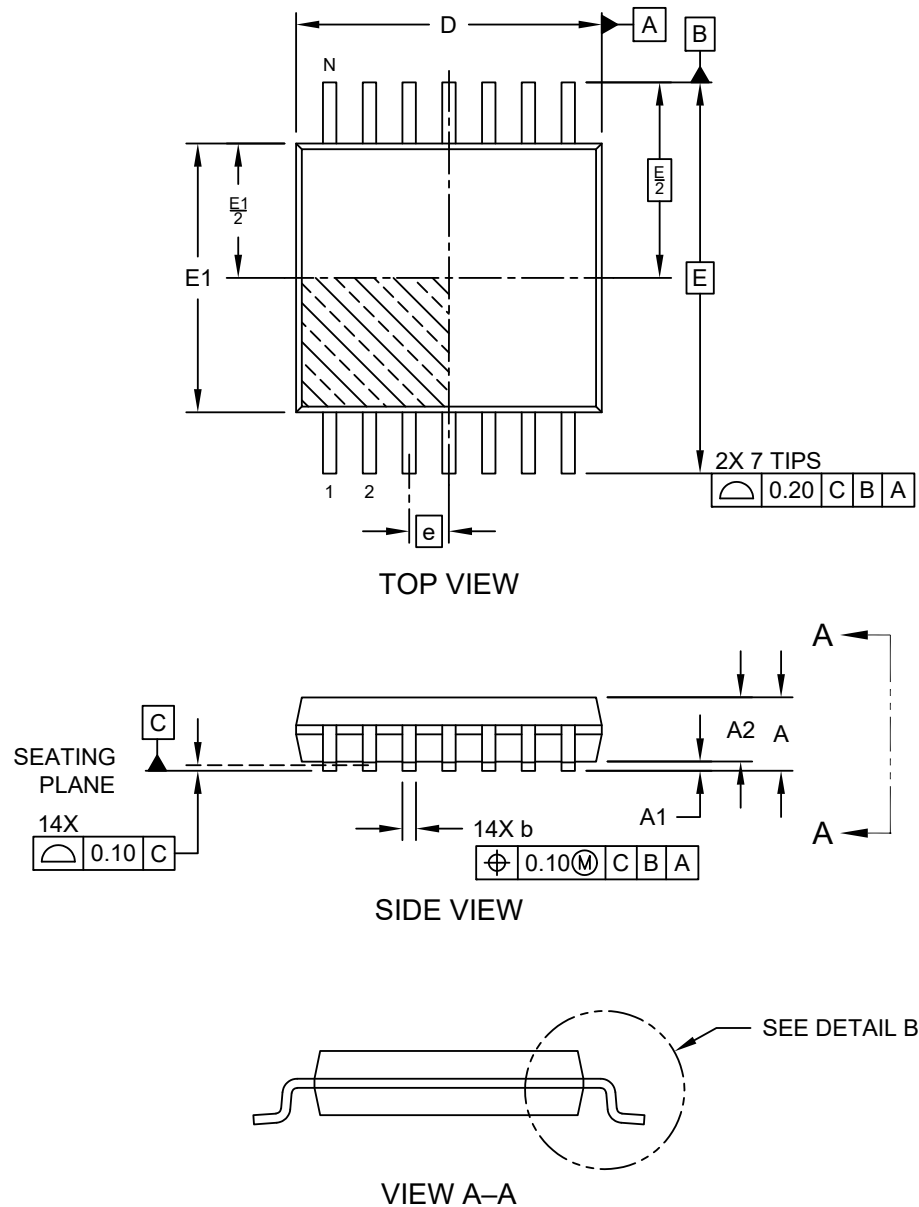

Microchip Technology Drawing C04-087-ST Rev F Sheet 1 of 2

14-Lead Plastic Thin Shrink Small Outline Package [ST] - 4.4 mm Body [TSSOP]

Note: For the most current package drawings, please see the Microchip Packaging Specification located at <http://www.microchip.com/packaging>

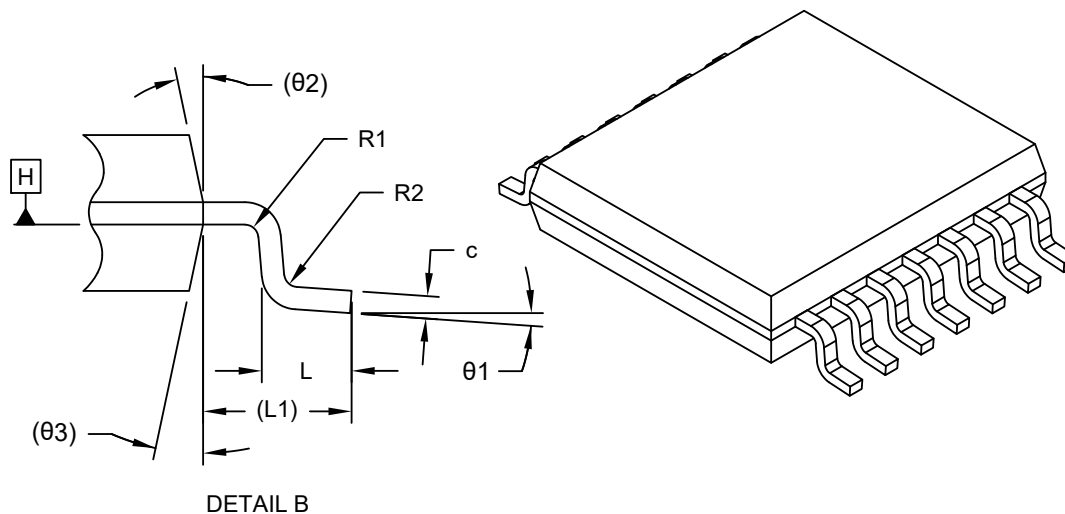

Dimension Limits	Units	MILLIMETERS		
		MIN	NOM	MAX
Number of Terminals	N	14		
Pitch	e	0.65 BSC		
Overall Height	A	–	–	1.20
Standoff	A1	0.05	–	0.15
Molded Package Thickness	A2	0.80	1.00	1.05
Overall Length	D	4.90	5.00	5.10
Overall Width	E	6.40 BSC		
Molded Package Width	E1	4.30	4.40	4.50
Terminal Width	b	0.19	–	0.30
Terminal Thickness	c	0.09	–	0.20
Terminal Length	L	0.45	0.60	0.75
Footprint	L1	1.00 REF		
Lead Bend Radius	R1	0.09	–	–
Lead Bend Radius	R2	0.09	–	–
Foot Angle	θ1	0°	–	8°
Mold Draft Angle	θ2	–	12° REF	–
Mold Draft Angle	θ3	–	12° REF	–

Notes:

- Pin 1 visual index feature may vary, but must be located within the hatched area.
- Dimensioning and tolerancing per ASME Y14.5M
BSC: Basic Dimension. Theoretically exact value shown without tolerances.
REF: Reference Dimension, usually without tolerance, for information purposes only.

Microchip Technology Drawing C04-087-ST Rev F Sheet 2 of 2

14-Lead Plastic Thin Shrink Small Outline Package [ST] – 4.4 mm Body [TSSOP]

Note: For the most current package drawings, please see the Microchip Packaging Specification located at <http://www.microchip.com/packaging>

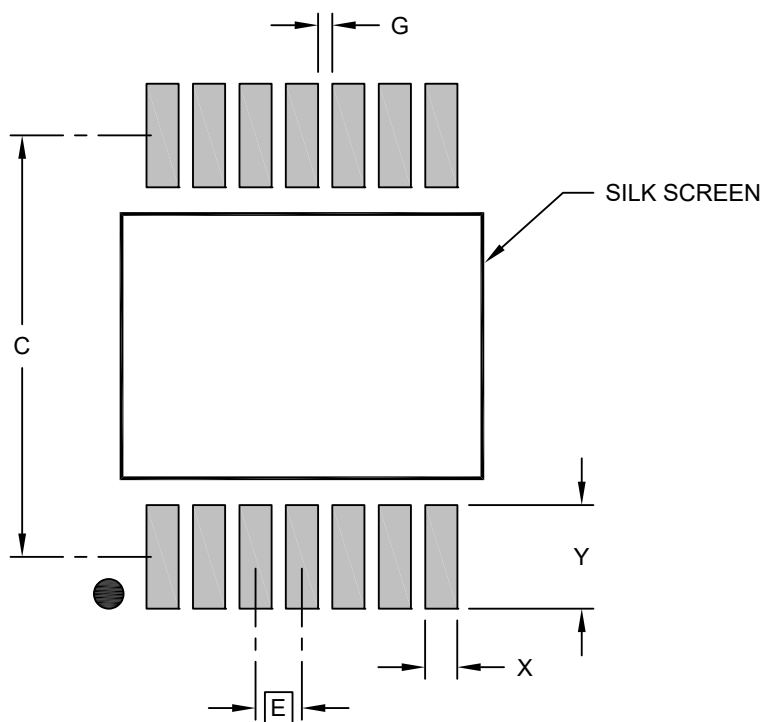

RECOMMENDED LAND PATTERN

Dimension Limits	Units	MILLIMETERS		
		MIN	NOM	MAX
Contact Pitch	E	0.65 BSC		
Contact Pad Spacing	C		5.90	
Contact Pad Width (X14)	X			0.45
Contact Pad Length (X14)	Y			1.45
Contact Pad to Contact Pad (X12)	G	0.20		

Notes:

- Dimensioning and tolerancing per ASME Y14.5M
BSC: Basic Dimension. Theoretically exact value shown without tolerances.

Microchip Technology Drawing C04-2087-ST Rev F

**16-Lead Plastic Quad Flat, No Lead Package (7N) - 4x4x1.0 mm Body [VQFN]
Wettable Flanks (Stepped), 0.40 mm Terminal Length**

Note: For the most current package drawings, please see the Microchip Packaging Specification located at <http://www.microchip.com/packaging>

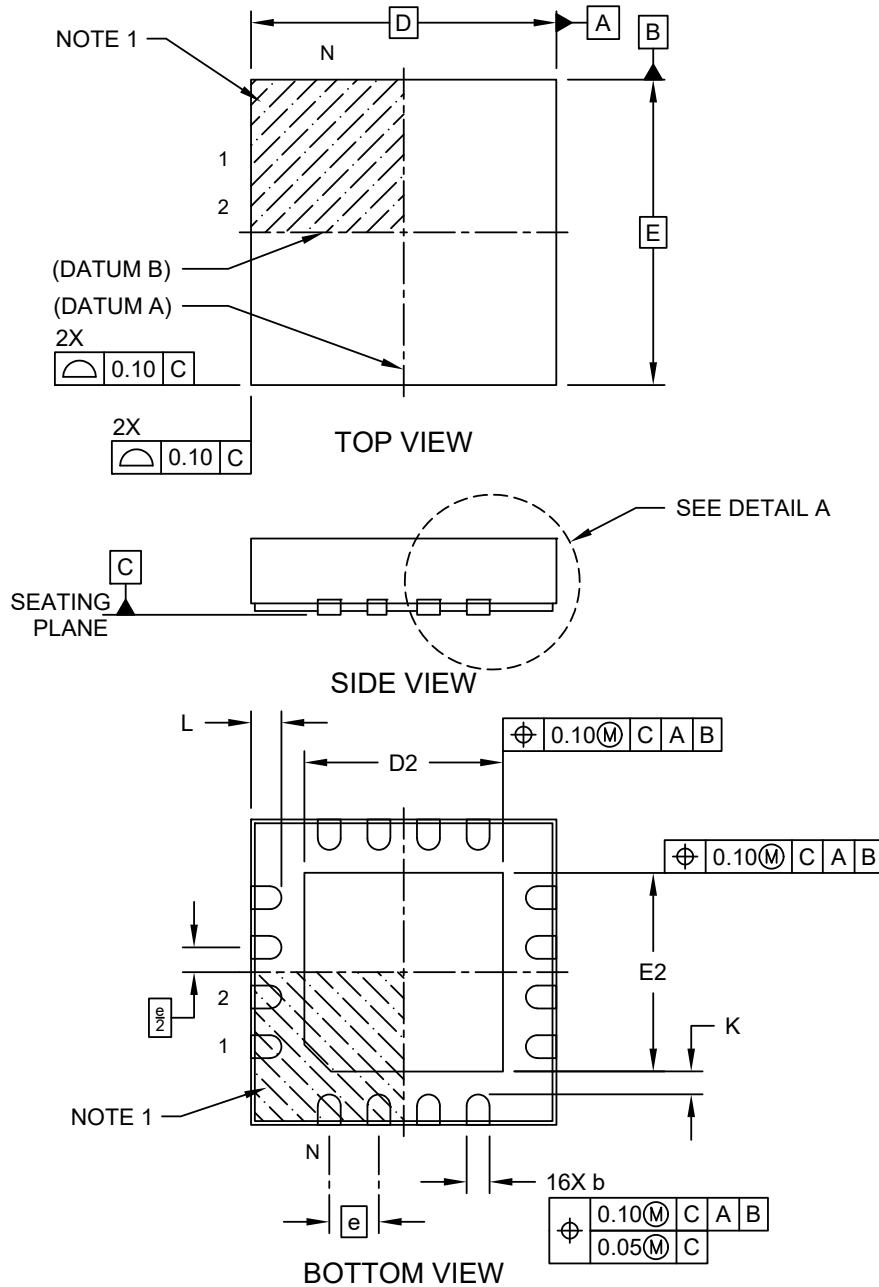

Microchip Technology Drawing C04-403-7N Rev. D Sheet 1 of 2

16-Lead Plastic Quad Flat, No Lead Package (7N) - 4x4x1.0 mm Body [VQFN] Wettable Flanks (Stepped), 0.40 mm Terminal Length

Note: For the most current package drawings, please see the Microchip Packaging Specification located at <http://www.microchip.com/packaging>

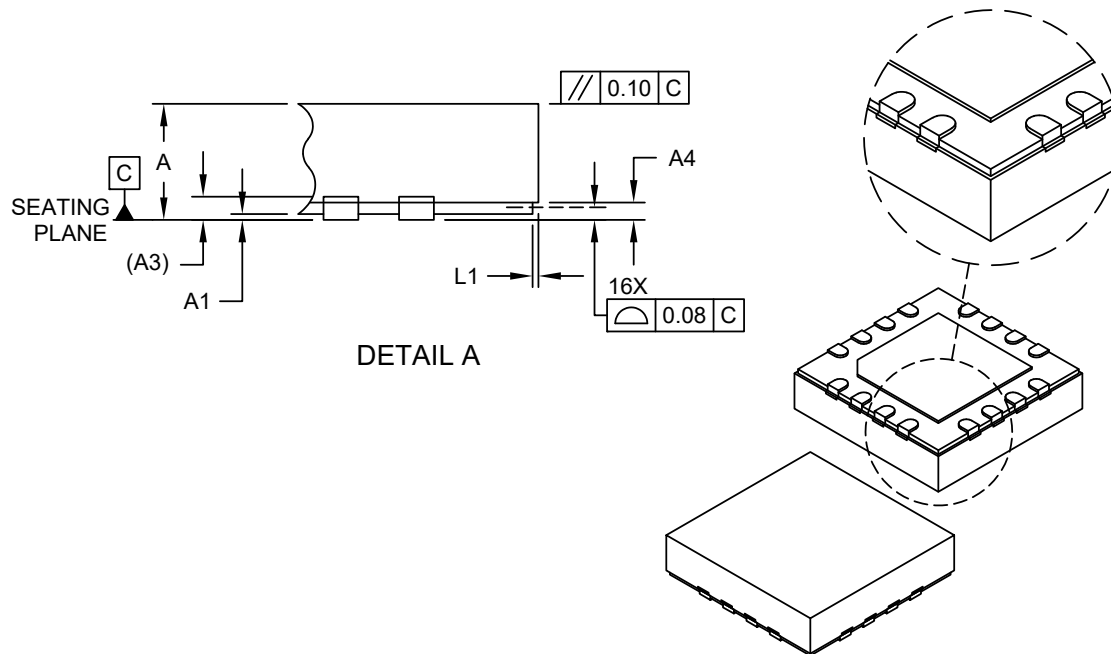

Dimension	Units	MILLIMETERS		
		MIN	NOM	MAX
Number of Terminals	N	16		
Pitch	e	0.65 BSC		
Overall Height	A	0.80	0.90	1.00
Standoff	A1	0.00	0.02	0.05
Terminal Thickness	A3	0.20 REF		
Step Height	A4	0.10	-	0.19
Overall Width	E	4.00 BSC		
Exposed Pad Width	E2	2.50	2.60	2.70
Overall Length	D	4.00 BSC		
Exposed Pad Length	D2	2.50	2.60	2.70
Terminal Width	b	0.25	0.30	0.35
Terminal Length	L	0.30	0.40	0.50
Step Length	L1	0.035	0.060	0.085
Terminal-to-Exposed Pad	K	0.30	-	-

Notes:

- Pin 1 visual index feature may vary, but must be located within the hatched area.
- Package is saw singulated
- Dimensioning and tolerancing per ASME Y14.5M
 - BSC: Basic Dimension. Theoretically exact value shown without tolerances.
 - REF: Reference Dimension, usually without tolerance, for information purposes only.

Microchip Technology Drawing C04-403-7N Rev. D Sheet 2 of 2

16-Lead Plastic Quad Flat, No Lead Package (7N) - 4x4x1.0 mm Body [VQFN] Wettable Flanks (Stepped), 0.40 mm Terminal Length

Note: For the most current package drawings, please see the Microchip Packaging Specification located at <http://www.microchip.com/packaging>

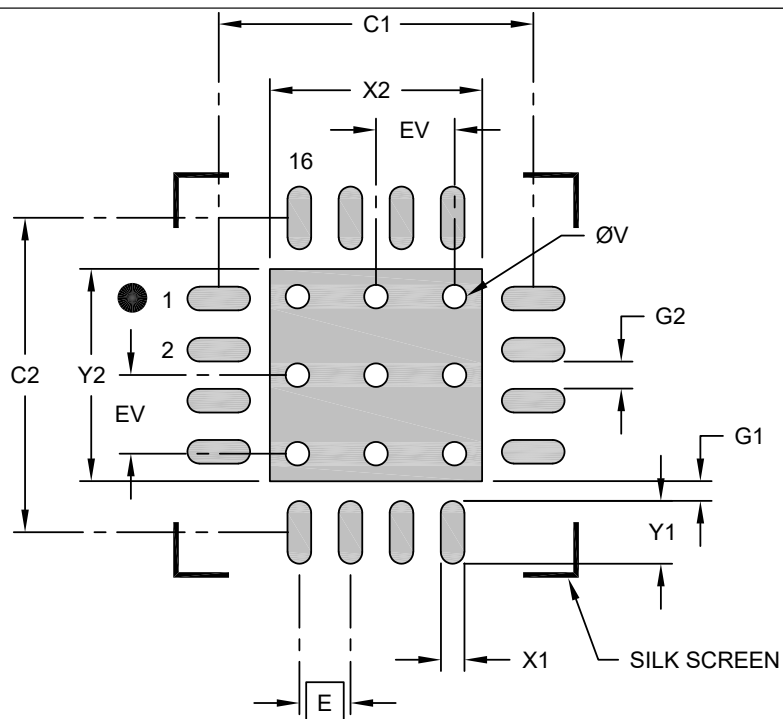

RECOMMENDED LAND PATTERN

Dimension Limits	Units	MILLIMETERS		
		MIN	NOM	MAX
Contact Pitch	E	0.65 BSC		
Optional Center Pad Width	X2			2.70
Optional Center Pad Length	Y2			2.70
Contact Pad Spacing	C1		4.00	
Contact Pad Spacing	C2		4.00	
Contact Pad Width (X16)	X1			0.30
Contact Pad Length (X16)	Y1			0.80
Contact Pad to Center Pad (X16)	G1	0.20		
Contact Pad to Contact Pad (X12)	G2	0.35		
Thermal Via Diameter	V		0.30	
Thermal Via Pitch	EV		1.00	

Notes:

- Dimensioning and tolerancing per ASME Y14.5M
BSC: Basic Dimension. Theoretically exact value shown without tolerances.
- For best soldering results, thermal vias, if used, should be filled or tented to avoid solder loss during reflow process

Microchip Technology Drawing C04-2403-7N Rev. D

20-Lead Plastic Dual In-Line (P) – 300 mil Body [PDIP]

Note: For the most current package drawings, please see the Microchip Packaging Specification located at <http://www.microchip.com/packaging>

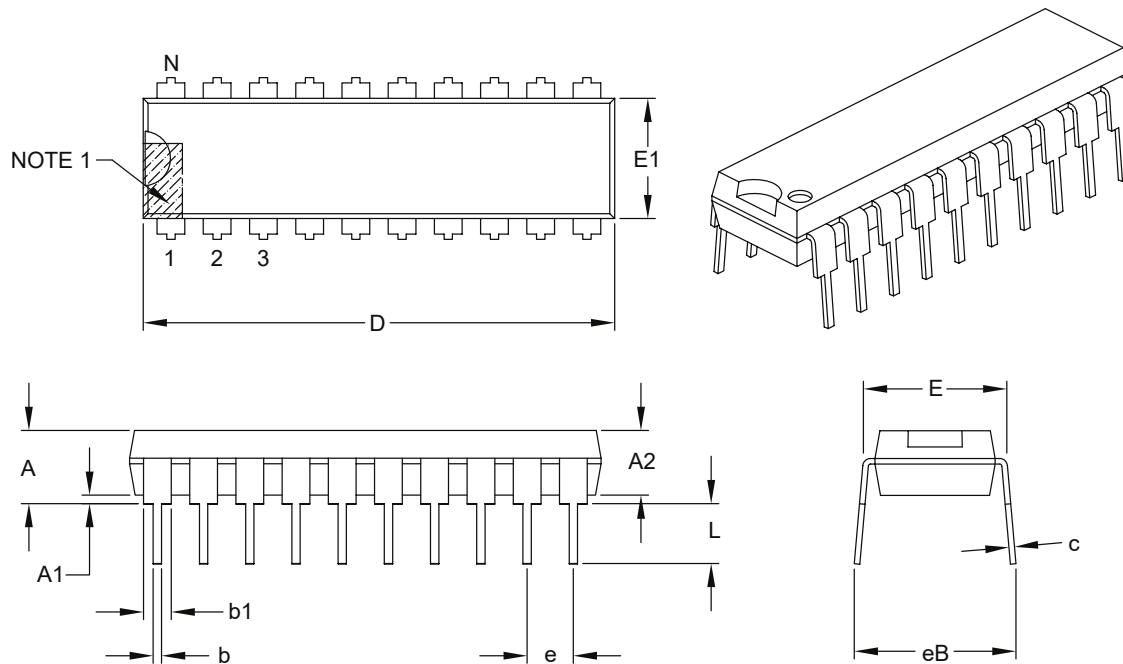

Dimension Limits	Units	INCHES		
		MIN	NOM	MAX
Number of Pins	N	20		
Pitch	e	.100 BSC		
Top to Seating Plane	A	–	–	.210
Molded Package Thickness	A2	.115	.130	.195
Base to Seating Plane	A1	.015	–	–
Shoulder to Shoulder Width	E	.300	.310	.325
Molded Package Width	E1	.240	.250	.280
Overall Length	D	.980	1.030	1.060
Tip to Seating Plane	L	.115	.130	.150
Lead Thickness	c	.008	.010	.015
Upper Lead Width	b1	.045	.060	.070
Lower Lead Width	b	.014	.018	.022
Overall Row Spacing §	eB	–	–	.430

Notes:

- Pin 1 visual index feature may vary, but must be located within the hatched area.
- § Significant Characteristic.
- Dimensions D and E1 do not include mold flash or protrusions. Mold flash or protrusions shall not exceed .010" per side.
- Dimensioning and tolerancing per ASME Y14.5M.

BSC: Basic Dimension. Theoretically exact value shown without tolerances.

Microchip Technology Drawing C04-019B

20-Lead Plastic Small Outline (SO) - Wide, 7.50 mm Body [SOIC]

Note: For the most current package drawings, please see the Microchip Packaging Specification located at <http://www.microchip.com/packaging>

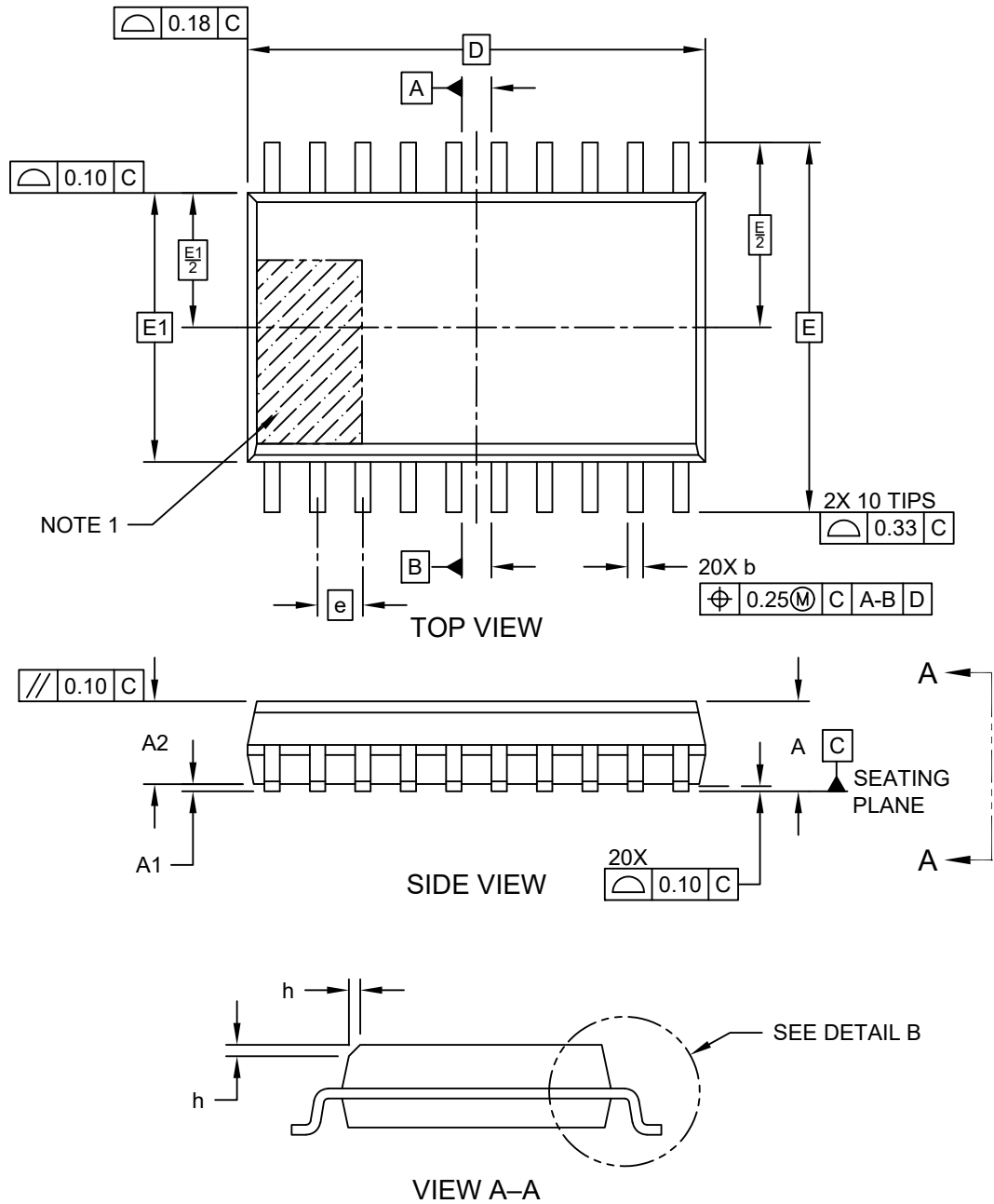

Microchip Technology Drawing C04-094 Rev F Sheet 1 of 2

20-Lead Plastic Small Outline (SO) - Wide, 7.50 mm Body [SOIC]

Note: For the most current package drawings, please see the Microchip Packaging Specification located at <http://www.microchip.com/packaging>

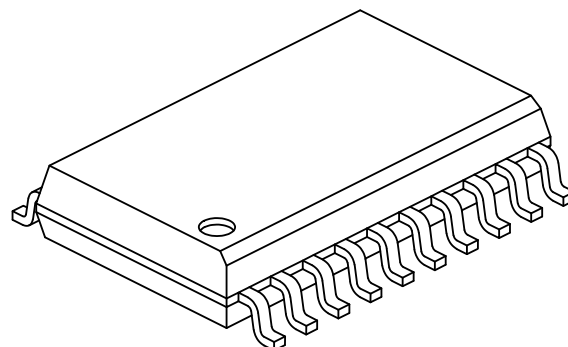
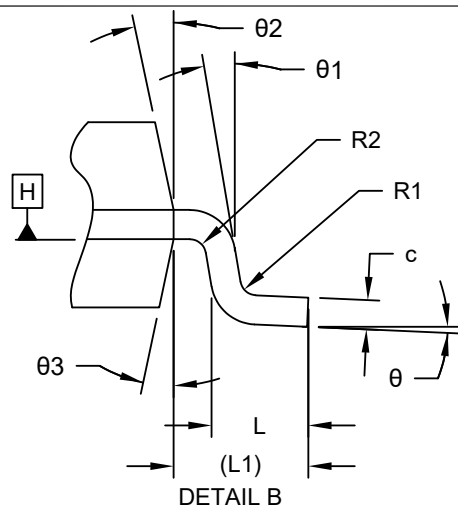

Dimension Limits	Units	MILLIMETERS		
		MIN	NOM	MAX
Number of Terminals	N	20		
Pitch	e	1.27 BSC		
Overall Height	A	-	-	2.65
Standoff §	A1	0.10	-	0.30
Molded Package Thickness	A2	2.05	-	-
Overall Length	D	12.78 BSC		
Overall Width	E	10.33 BSC		
Molded Package Width	E1	7.49 BSC		
Terminal Width	b	0.31	-	0.51
Terminal Thickness	c	0.25	-	0.75
Corner Chamfer	h	0.25	-	0.75
Terminal Length	L	0.40	0.65	1.27
Footprint	L1	1.40 REF		
Lead Bend Radius	R1	0.07	-	-
Lead Bend Radius	R2	0.07	-	-
Foot Angle	θ	0°	-	8°
Lead Angle	θ1	0°	-	-
Mold Draft Angle	θ2	5°	-	15°
Mold Draft Angle	θ3	5°	-	15°

Notes:

- Pin 1 visual index feature may vary, but must be located within the hatched area.
- Dimensioning and tolerancing per ASME Y14.5M
BSC: Basic Dimension. Theoretically exact value shown without tolerances.
REF: Reference Dimension, usually without tolerance, for information purposes only.
- Dimension D does not include mold flash, protrusions or gate burrs, which shall not exceed 0.15 mm per end. Dimension E1 does not include interlead flash or protrusion, which shall not exceed 0.25 mm per side.
- § Significant Characteristic

Microchip Technology Drawing C04-094 Rev F Sheet 2 of 2

20-Lead Plastic Small Outline (SO) - Wide, 7.50 mm Body [SOIC]

Note: For the most current package drawings, please see the Microchip Packaging Specification located at <http://www.microchip.com/packaging>

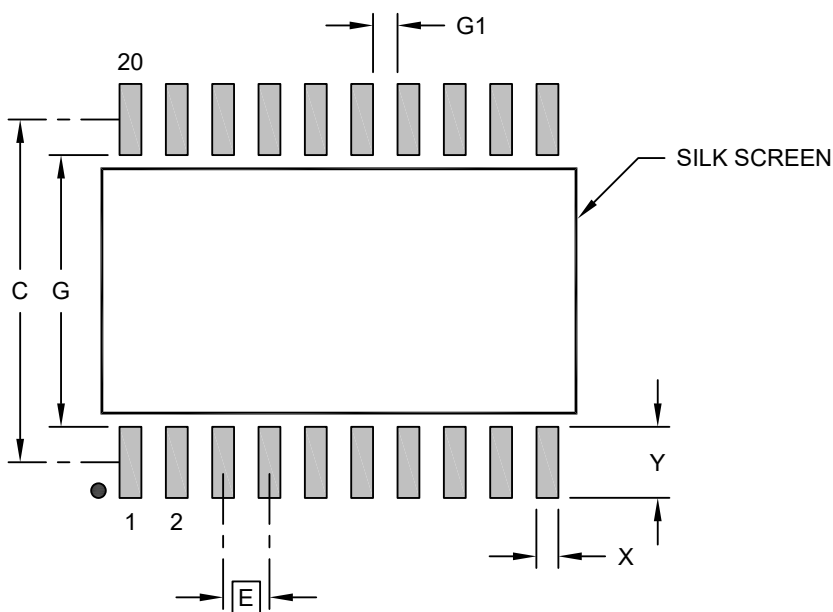

RECOMMENDED LAND PATTERN

		MILLIMETERS		
Units		MIN	NOM	MAX
Dimension Limits				
Contact Pitch	E	1.27 BSC		
Contact Pad Spacing	C		9.40	
Contact Pad Width (X20)	X			0.60
Contact Pad Length (X20)	Y			1.95
Contact Pad to Contact Pad	G	0.67		
Contact Pad to Contact Pad	G1	7.45		

Notes:

- Dimensioning and tolerancing per ASME Y14.5M
BSC: Basic Dimension. Theoretically exact value shown without tolerances.
- For best soldering results, thermal vias, if used, should be filled or tented to avoid solder loss during reflow process

Microchip Technology Drawing C04-2094 Rev
F

**20-Lead Plastic Quad Flat, No Lead Package (6N,6NX) - 4x4x1.0 mm Body [VQFN]
Wettable Flanks (Stepped), 0.40 mm Terminal Length**

Note: For the most current package drawings, please see the Microchip Packaging Specification located at <http://www.microchip.com/packaging>

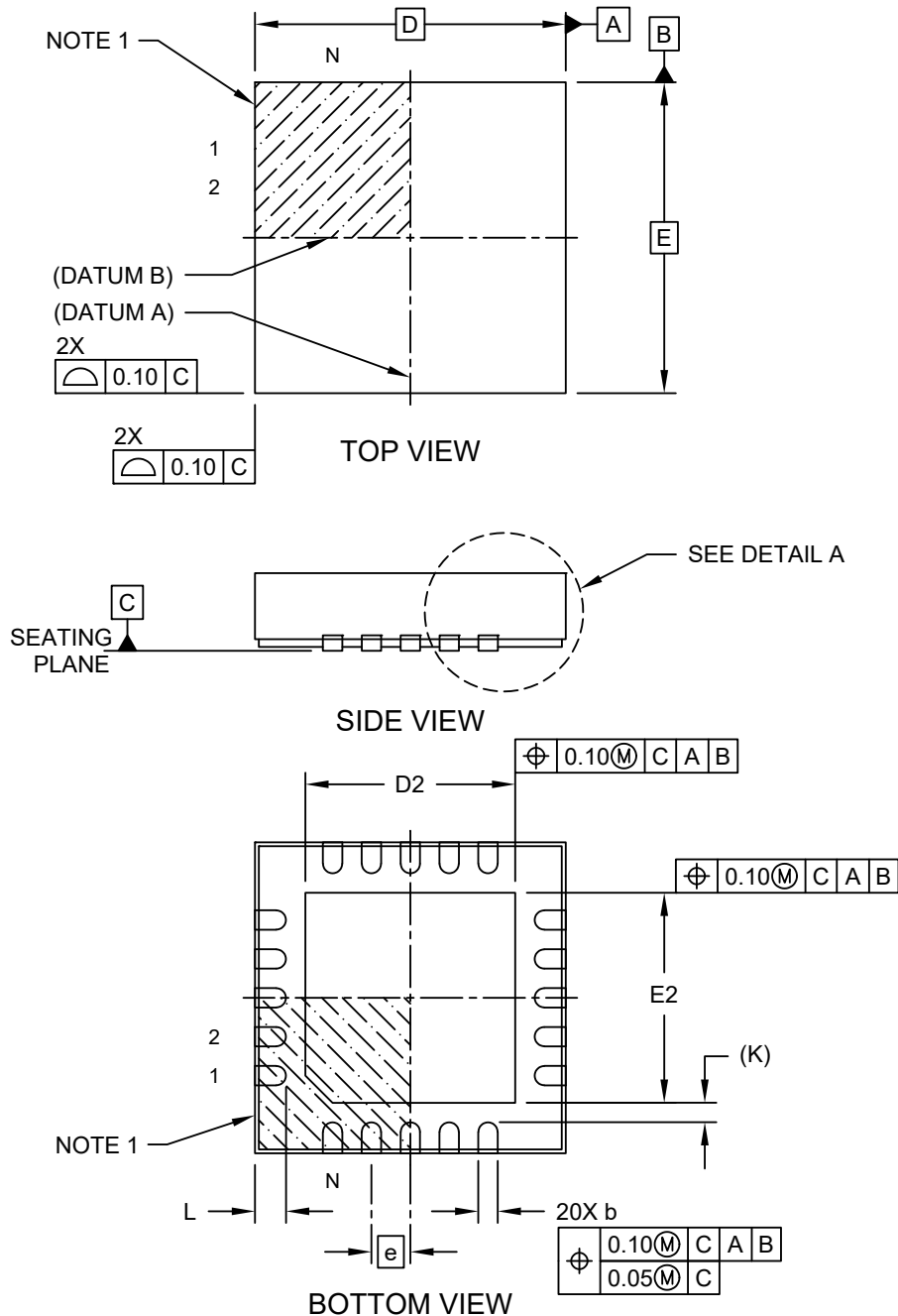

Microchip Technology Drawing C04-402E Sheet 1 of 2

20-Lead Plastic Quad Flat, No Lead Package (6N,6NX) - 4x4x1.0 mm Body [VQFN] Wettable Flanks (Stepped), 0.40 mm Terminal Length

Note: For the most current package drawings, please see the Microchip Packaging Specification located at <http://www.microchip.com/packaging>

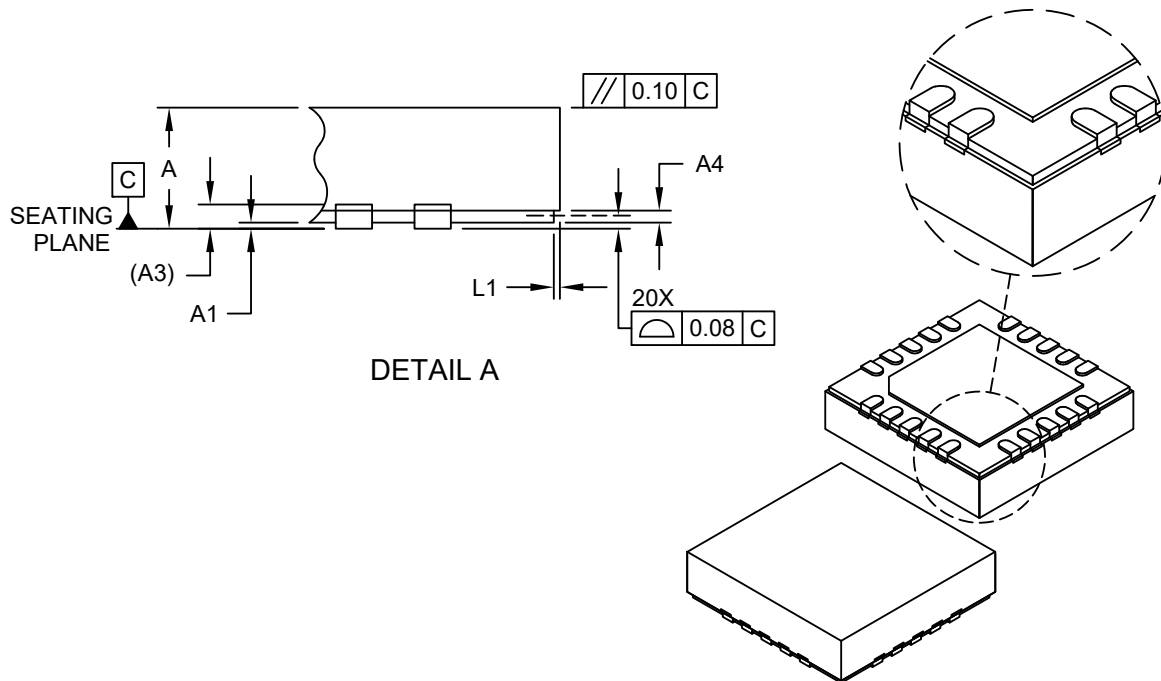

Dimension Limits	Units	MILLIMETERS		
		MIN	NOM	MAX
Number of Terminals	N	20		
Pitch	e	0.50 BSC		
Overall Height	A	0.80	0.90	1.00
Standoff	A1	0.00	0.02	0.05
Terminal Thickness	A3	0.20 REF		
Step Height	A4	0.10	-	0.19
Overall Width	E	4.00 BSC		
Exposed Pad Width	E2	2.60	2.70	2.80
Overall Length	D	4.00 BSC		
Exposed Pad Length	D2	2.60	2.70	2.80
Terminal Width	b	0.20	0.25	0.30
Terminal Length	L	0.30	0.40	0.50
Step Length	L1	0.035	0.060	0.085
Terminal-to-Exposed Pad	K	0.25 REF		

Notes:

1. Pin 1 visual index feature may vary, but must be located within the hatched area.
2. Package is saw singulated
3. Dimensioning and tolerancing per ASME Y14.5M

BSC: Basic Dimension. Theoretically exact value shown without tolerances.

REF: Reference Dimension, usually without tolerance, for information purposes only.

Microchip Technology Drawing C04-402E Sheet 2 of 2

**20-Lead Plastic Quad Flat, No Lead Package (6N,6NX) - 4x4x1.0 mm Body [VQFN]
Wettable Flanks (Stepped), 0.40 mm Terminal Length**

Note: For the most current package drawings, please see the Microchip Packaging Specification located at <http://www.microchip.com/packaging>

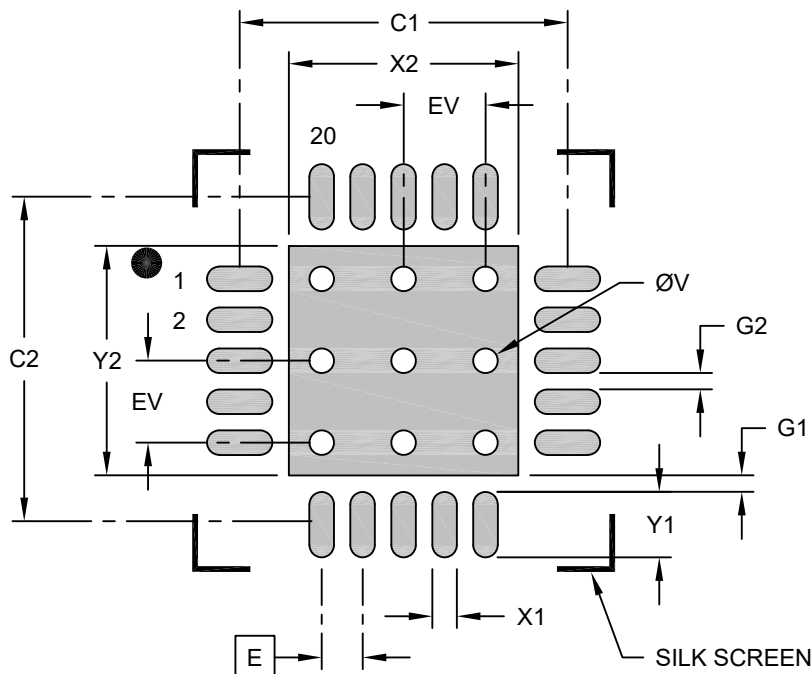

RECOMMENDED LAND PATTERN

Dimension Limits	Units	MILLIMETERS		
		MIN	NOM	MAX
Contact Pitch	E	0.50 BSC		
Optional Center Pad Width	X2			2.80
Optional Center Pad Length	Y2			2.80
Contact Pad Spacing	C1		4.00	
Contact Pad Spacing	C2		4.00	
Contact Pad Width (X20)	X1			0.30
Contact Pad Length (X20)	Y1			0.80
Contact Pad to Center Pad (X20)	G1	0.25		
Contact Pad to Contact Pad (X16)	G2	0.20		
Thermal Via Diameter	V		0.30	
Thermal Via Pitch	EV		1.00	

Notes:

1. Dimensioning and tolerancing per ASME Y14.5M
BSC: Basic Dimension. Theoretically exact value shown without tolerances.
2. For best soldering results, thermal vias, if used, should be filled or tented to avoid solder loss during reflow process

Microchip Technology Drawing C04-2402E

20-Lead Plastic Shrink Small Outline (SS) - 5.30 mm Body [SSOP]

Note: For the most current package drawings, please see the Microchip Packaging Specification located at <http://www.microchip.com/packaging>

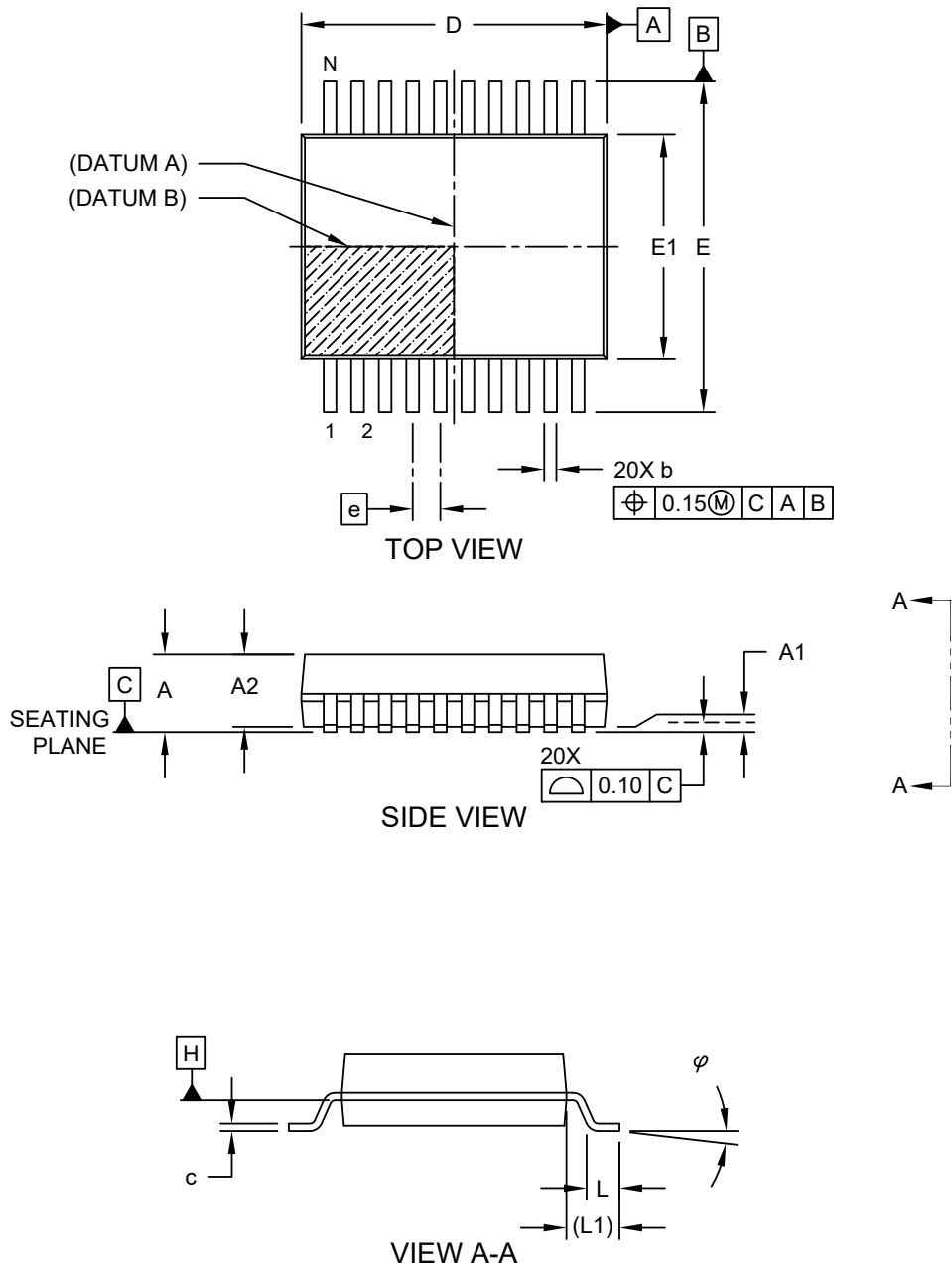

Microchip Technology Drawing C04-072 Rev C Sheet 1 of 2

20-Lead Plastic Shrink Small Outline (SS) - 5.30 mm Body [SSOP]

Note: For the most current package drawings, please see the Microchip Packaging Specification located at <http://www.microchip.com/packaging>

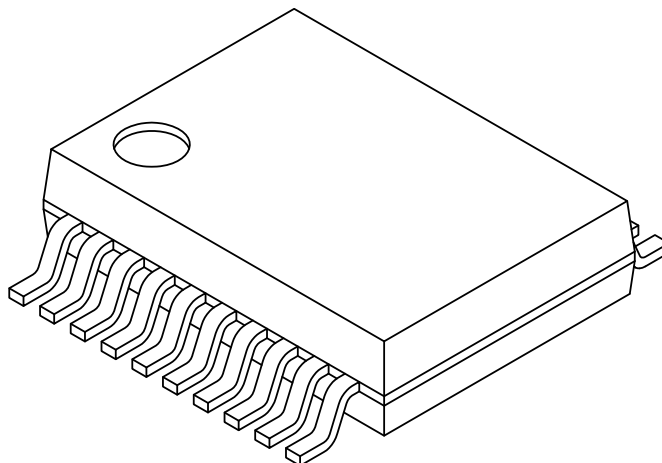

Dimension Limits	Units	MILLIMETERS		
		MIN	NOM	MAX
Number of Pins	N	20		
Pitch	e	0.65 BSC		
Overall Height	A	-	-	2.00
Molded Package Thickness	A2	1.65	1.75	1.85
Standoff	A1	0.05	-	-
Overall Width	E	7.40	7.80	8.20
Molded Package Width	E1	5.00	5.30	5.60
Overall Length	D	6.90	7.20	7.50
Foot Length	L	0.55	0.75	0.95
Footprint	L1	1.25 REF		
Lead Thickness	c	0.09	-	0.25
Foot Angle	φ	0°	4°	8°
Lead Width	b	0.22	-	0.38

Notes:

- Pin 1 visual index feature may vary, but must be located within the hatched area.
- Dimensions D and E1 do not include mold flash or protrusions. Mold flash or protrusions shall not exceed 0.20mm per side.
- Dimensioning and tolerancing per ASME Y14.5M

BSC: Basic Dimension. Theoretically exact value shown without tolerances.

REF: Reference Dimension, usually without tolerance, for information purposes only.

Microchip Technology Drawing C04-072 Rev C Sheet 2 of 2

20-Lead Plastic Shrink Small Outline (SS) - 5.30 mm Body [SSOP]

Note: For the most current package drawings, please see the Microchip Packaging Specification located at <http://www.microchip.com/packaging>

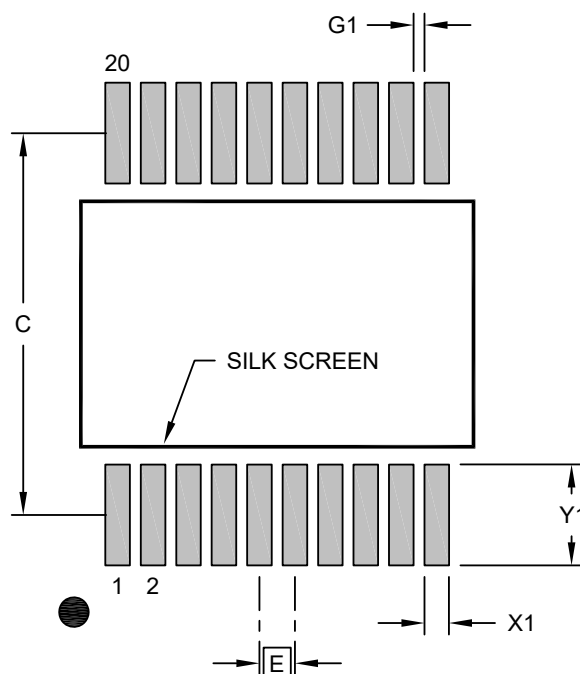

RECOMMENDED LAND PATTERN

Dimension Limits	Units	MILLIMETERS		
		MIN	NOM	MAX
Contact Pitch	E	0.65 BSC		
Contact Pad Spacing	C		7.00	
Contact Pad Width (X20)	X1			0.45
Contact Pad Length (X20)	Y1			1.85
Contact Pad to Center Pad (X18)	G1	0.20		

Notes:

- Dimensioning and tolerancing per ASME Y14.5M
BSC: Basic Dimension. Theoretically exact value shown without tolerances.
- For best soldering results, thermal vias, if used, should be filled or tented to avoid solder loss during reflow process

Microchip Technology Drawing C04-2072 Rev C

46. Appendix A: Revision History

Doc. Rev.	Date	Comments
E	10/2023	Updated electrical specs; other minor corrections and improvements.
D	8/2022	Updated electrical spec data; other minor corrections and improvements.
C	3/2022	Adding Charge Pump section.
B	2/2022	Preliminary document release.
A	8/2021	Initial document release.

Microchip Information

The Microchip Website

Microchip provides online support via our website at www.microchip.com/. This website is used to make files and information easily available to customers. Some of the content available includes:

- **Product Support** – Data sheets and errata, application notes and sample programs, design resources, user's guides and hardware support documents, latest software releases and archived software
- **General Technical Support** – Frequently Asked Questions (FAQs), technical support requests, online discussion groups, Microchip design partner program member listing
- **Business of Microchip** – Product selector and ordering guides, latest Microchip press releases, listing of seminars and events, listings of Microchip sales offices, distributors and factory representatives

Product Change Notification Service

Microchip's product change notification service helps keep customers current on Microchip products. Subscribers will receive email notification whenever there are changes, updates, revisions or errata related to a specified product family or development tool of interest.

To register, go to www.microchip.com/pcn and follow the registration instructions.

Customer Support

Users of Microchip products can receive assistance through several channels:

- Distributor or Representative
- Local Sales Office
- Embedded Solutions Engineer (ESE)
- Technical Support

Customers should contact their distributor, representative or ESE for support. Local sales offices are also available to help customers. A listing of sales offices and locations is included in this document.

Technical support is available through the website at: www.microchip.com/support

Product Identification System

To order or obtain information, e.g., on pricing or delivery, refer to the factory or the listed sales office.

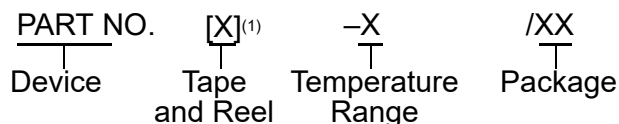

Device:	PIC16F18126, PIC16F18146	
Tape & Reel Option:	Blank	= Tube
	T	= Tape & Reel
Temperature Range:	I	= -40°C to +85°C (Industrial)
	E	= -40°C to +125°C (Extended)
Package:	P	= 14-lead PDIP
	SL	= 14-lead SOIC
	ST	= 14-lead TSSOP
	7N	= 16-lead VQFN
	P	= 20-lead PDIP
	SO	= 20-lead SOIC
	SS	= 20-lead SSOP
	6N	= 20-lead VQFN

Examples:

- PIC16F18126 T-E/P: Tape and Reel, Extended temperature, 14-lead PDIP
- PIC16F18146 T-I/SS: Tape and Reel, Industrial temperature, 20-lead SSOP

Notes:

1. Tape and Reel identifier only appears in the catalog part number description. This identifier is used for ordering purposes and is not printed on the device package. Check with your Microchip Sales Office for package availability with the Tape and Reel option.
2. Small form-factor packaging options may be available. Please check www.microchip.com/packaging for small-form factor package availability, or contact your local Sales Office.

Microchip Devices Code Protection Feature

Note the following details of the code protection feature on Microchip products:

- Microchip products meet the specifications contained in their particular Microchip Data Sheet.
- Microchip believes that its family of products is secure when used in the intended manner, within operating specifications, and under normal conditions.
- Microchip values and aggressively protects its intellectual property rights. Attempts to breach the code protection features of Microchip product is strictly prohibited and may violate the Digital Millennium Copyright Act.
- Neither Microchip nor any other semiconductor manufacturer can guarantee the security of its code. Code protection does not mean that we are guaranteeing the product is “unbreakable”. Code protection is constantly evolving. Microchip is committed to continuously improving the code protection features of our products.

Legal Notice

This publication and the information herein may be used only with Microchip products, including to design, test, and integrate Microchip products with your application. Use of this information in any other manner violates these terms. Information regarding device applications is provided

only for your convenience and may be superseded by updates. It is your responsibility to ensure that your application meets with your specifications. Contact your local Microchip sales office for additional support or, obtain additional support at www.microchip.com/en-us/support/design-help/client-support-services.

THIS INFORMATION IS PROVIDED BY MICROCHIP "AS IS". MICROCHIP MAKES NO REPRESENTATIONS OR WARRANTIES OF ANY KIND WHETHER EXPRESS OR IMPLIED, WRITTEN OR ORAL, STATUTORY OR OTHERWISE, RELATED TO THE INFORMATION INCLUDING BUT NOT LIMITED TO ANY IMPLIED WARRANTIES OF NON-INFRINGEMENT, MERCHANTABILITY, AND FITNESS FOR A PARTICULAR PURPOSE, OR WARRANTIES RELATED TO ITS CONDITION, QUALITY, OR PERFORMANCE.

IN NO EVENT WILL MICROCHIP BE LIABLE FOR ANY INDIRECT, SPECIAL, PUNITIVE, INCIDENTAL, OR CONSEQUENTIAL LOSS, DAMAGE, COST, OR EXPENSE OF ANY KIND WHATSOEVER RELATED TO THE INFORMATION OR ITS USE, HOWEVER CAUSED, EVEN IF MICROCHIP HAS BEEN ADVISED OF THE POSSIBILITY OR THE DAMAGES ARE FORESEEABLE. TO THE FULLEST EXTENT ALLOWED BY LAW, MICROCHIP'S TOTAL LIABILITY ON ALL CLAIMS IN ANY WAY RELATED TO THE INFORMATION OR ITS USE WILL NOT EXCEED THE AMOUNT OF FEES, IF ANY, THAT YOU HAVE PAID DIRECTLY TO MICROCHIP FOR THE INFORMATION.

Use of Microchip devices in life support and/or safety applications is entirely at the buyer's risk, and the buyer agrees to defend, indemnify and hold harmless Microchip from any and all damages, claims, suits, or expenses resulting from such use. No licenses are conveyed, implicitly or otherwise, under any Microchip intellectual property rights unless otherwise stated.

Trademarks

The Microchip name and logo, the Microchip logo, Adaptec, AVR, AVR logo, AVR Freaks, BesTime, BitCloud, CryptoMemory, CryptoRF, dsPIC, flexPWR, HELDO, IGLOO, JukeBlox, KeeLoq, Kleer, LANCheck, LinkMD, maXStylus, maXTouch, MediaLB, megaAVR, Microsemi, Microsemi logo, MOST, MOST logo, MPLAB, OptoLyzer, PIC, picoPower, PICSTART, PIC32 logo, PolarFire, Prochip Designer, QTouch, SAM-BA, SenGenuity, SpyNIC, SST, SST Logo, SuperFlash, Symmetricom, SyncServer, Tachyon, TimeSource, tinyAVR, UNI/O, Vectron, and XMEGA are registered trademarks of Microchip Technology Incorporated in the U.S.A. and other countries.

AgileSwitch, ClockWorks, The Embedded Control Solutions Company, EtherSynch, Flashtec, Hyper Speed Control, HyperLight Load, Libero, motorBench, mTouch, Powermite 3, Precision Edge, ProASIC, ProASIC Plus, ProASIC Plus logo, Quiet-Wire, SmartFusion, SyncWorld, TimeCesium, TimeHub, TimePictra, TimeProvider, and ZL are registered trademarks of Microchip Technology Incorporated in the U.S.A.

Adjacent Key Suppression, AKS, Analog-for-the-Digital Age, Any Capacitor, AnyIn, AnyOut, Augmented Switching, BlueSky, BodyCom, Clockstudio, CodeGuard, CryptoAuthentication, CryptoAutomotive, CryptoCompanion, CryptoController, dsPICDEM, dsPICDEM.net, Dynamic Average Matching, DAM, ECAN, Espresso T1S, EtherGREEN, EyeOpen, GridTime, IdealBridge, IGaT, In-Circuit Serial Programming, ICSP, INICnet, Intelligent Paralleling, IntelliMOS, Inter-Chip Connectivity, JitterBlocker, Knob-on-Display, MarginLink, maxCrypto, maxView, memBrain, Mindi, MiWi, MPASM, MPF, MPLAB Certified logo, MPLIB, MPLINK, mSiC, MultiTRAK, NetDetach, Omniscient Code Generation, PICDEM, PICDEM.net, PICkit, PICtail, Power MOS IV, Power MOS 7, PowerSmart, PureSilicon, QMatrix, REAL ICE, Ripple Blocker, RTAX, RTG4, SAM-ICE, Serial Quad I/O, simpleMAP, SimpliPHY, SmartBuffer, SmartHLS, SMART-I.S., storClad, SQI, SuperSwitcher, SuperSwitcher II, Switchtec, SynchroPHY, Total Endurance, Trusted Time, TSHARC, Turing, USBCheck, VariSense, VectorBlox, VeriPHY, ViewSpan, WiperLock, XpressConnect, and ZENA are trademarks of Microchip Technology Incorporated in the U.S.A. and other countries.

SQTP is a service mark of Microchip Technology Incorporated in the U.S.A.

The Adaptec logo, Frequency on Demand, Silicon Storage Technology, and Symmcom are registered trademarks of Microchip Technology Inc. in other countries.

GestIC is a registered trademark of Microchip Technology Germany II GmbH & Co. KG, a subsidiary of Microchip Technology Inc., in other countries.

All other trademarks mentioned herein are property of their respective companies.

© 2021-2023, Microchip Technology Incorporated and its subsidiaries. All Rights Reserved.

ISBN: 978-1-6683-3123-1

Quality Management System

For information regarding Microchip's Quality Management Systems, please visit www.microchip.com/quality.

Worldwide Sales and Service

AMERICAS	ASIA/PACIFIC	ASIA/PACIFIC	EUROPE
<p>Corporate Office 2355 West Chandler Blvd. Chandler, AZ 85224-6199 Tel: 480-792-7200 Fax: 480-792-7277 Technical Support: www.microchip.com/support Web Address: www.microchip.com</p> <p>Atlanta Duluth, GA Tel: 678-957-9614 Fax: 678-957-1455</p> <p>Austin, TX Tel: 512-257-3370</p> <p>Boston Westborough, MA Tel: 774-760-0087 Fax: 774-760-0088</p> <p>Chicago Itasca, IL Tel: 630-285-0071 Fax: 630-285-0075</p> <p>Dallas Addison, TX Tel: 972-818-7423 Fax: 972-818-2924</p> <p>Detroit Novi, MI Tel: 248-848-4000</p> <p>Houston, TX Tel: 281-894-5983</p> <p>Indianapolis Noblesville, IN Tel: 317-773-8323 Fax: 317-773-5453 Tel: 317-536-2380</p> <p>Los Angeles Mission Viejo, CA Tel: 949-462-9523 Fax: 949-462-9608 Tel: 951-273-7800</p> <p>Raleigh, NC Tel: 919-844-7510</p> <p>New York, NY Tel: 631-435-6000</p> <p>San Jose, CA Tel: 408-735-9110 Tel: 408-436-4270</p> <p>Canada - Toronto Tel: 905-695-1980 Fax: 905-695-2078</p>	<p>Australia - Sydney Tel: 61-2-9868-6733</p> <p>China - Beijing Tel: 86-10-8569-7000</p> <p>China - Chengdu Tel: 86-28-8665-5511</p> <p>China - Chongqing Tel: 86-23-8980-9588</p> <p>China - Dongguan Tel: 86-769-8702-9880</p> <p>China - Guangzhou Tel: 86-20-8755-8029</p> <p>China - Hangzhou Tel: 86-571-8792-8115</p> <p>China - Hong Kong SAR Tel: 852-2943-5100</p> <p>China - Nanjing Tel: 86-25-8473-2460</p> <p>China - Qingdao Tel: 86-532-8502-7355</p> <p>China - Shanghai Tel: 86-21-3326-8000</p> <p>China - Shenyang Tel: 86-24-2334-2829</p> <p>China - Shenzhen Tel: 86-755-8864-2200</p> <p>China - Suzhou Tel: 86-186-6233-1526</p> <p>China - Wuhan Tel: 86-27-5980-5300</p> <p>China - Xian Tel: 86-29-8833-7252</p> <p>China - Xiamen Tel: 86-592-2388138</p> <p>China - Zhuhai Tel: 86-756-3210040</p>	<p>India - Bangalore Tel: 91-80-3090-4444</p> <p>India - New Delhi Tel: 91-11-4160-8631</p> <p>India - Pune Tel: 91-20-4121-0141</p> <p>Japan - Osaka Tel: 81-6-6152-7160</p> <p>Japan - Tokyo Tel: 81-3-6880-3770</p> <p>Korea - Daegu Tel: 82-53-744-4301</p> <p>Korea - Seoul Tel: 82-2-554-7200</p> <p>Malaysia - Kuala Lumpur Tel: 60-3-7651-7906</p> <p>Malaysia - Penang Tel: 60-4-227-8870</p> <p>Philippines - Manila Tel: 63-2-634-9065</p> <p>Singapore Tel: 65-6334-8870</p> <p>Taiwan - Hsin Chu Tel: 886-3-577-8366</p> <p>Taiwan - Kaohsiung Tel: 886-7-213-7830</p> <p>Taiwan - Taipei Tel: 886-2-2508-8600</p> <p>Thailand - Bangkok Tel: 66-2-694-1351</p> <p>Vietnam - Ho Chi Minh Tel: 84-28-5448-2100</p>	<p>Austria - Wels Tel: 43-7242-2244-39 Fax: 43-7242-2244-393</p> <p>Denmark - Copenhagen Tel: 45-4485-5910 Fax: 45-4485-2829</p> <p>Finland - Espoo Tel: 358-9-4520-820</p> <p>France - Paris Tel: 33-1-69-53-63-20 Fax: 33-1-69-30-90-79</p> <p>Germany - Garching Tel: 49-8931-9700</p> <p>Germany - Haan Tel: 49-2129-3766400</p> <p>Germany - Heilbronn Tel: 49-7131-72400</p> <p>Germany - Karlsruhe Tel: 49-721-625370</p> <p>Germany - Munich Tel: 49-89-627-144-0 Fax: 49-89-627-144-44</p> <p>Germany - Rosenheim Tel: 49-8031-354-560</p> <p>Israel - Ra'anana Tel: 972-9-744-7705</p> <p>Italy - Milan Tel: 39-0331-742611 Fax: 39-0331-466781</p> <p>Italy - Padova Tel: 39-049-7625286</p> <p>Netherlands - Drunen Tel: 31-416-690399 Fax: 31-416-690340</p> <p>Norway - Trondheim Tel: 47-72884388</p> <p>Poland - Warsaw Tel: 48-22-3325737</p> <p>Romania - Bucharest Tel: 40-21-407-87-50</p> <p>Spain - Madrid Tel: 34-91-708-08-90 Fax: 34-91-708-08-91</p> <p>Sweden - Gothenberg Tel: 46-31-704-60-40</p> <p>Sweden - Stockholm Tel: 46-8-5090-4654</p> <p>UK - Wokingham Tel: 44-118-921-5800 Fax: 44-118-921-5820</p>