

Scope

This user's guide introduces the SAM9X60-Curiosity board (EV40E67A) and describes the development and debugging capabilities running on SAM9 Arm®-based embedded MPUs.

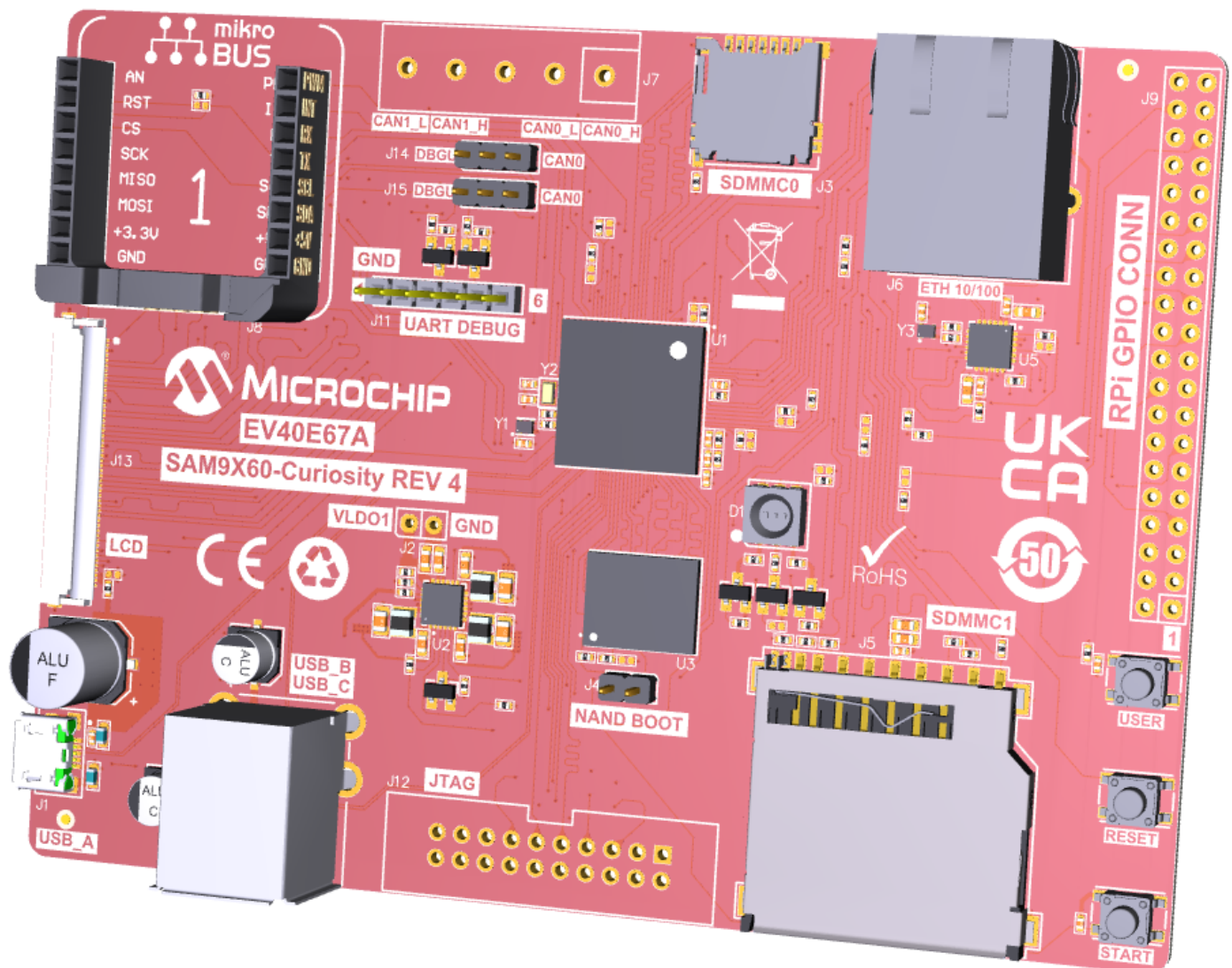

1. Introduction

1.1 Document Layout

The document is organized as follows:

- Chapter 1. "Introduction"
- Chapter 2. "Product Overview" – Important information about the SAM9X60-Curiosity board
- Chapter 3. "Function Blocks" – Specifications of the SAM9X60-Curiosity and high-level description of the major components and interfaces
- Chapter 4. "Installation and Operation" – Instructions on how to get started with the SAM9X60-Curiosity board
- Appendix. "Schematics and Layouts" – SAM9X60-Curiosity schematics and layout diagrams

1.2 Recommended Reading

The following Microchip documents are available and recommended as supplemental reference resources:

- SAM9X60 Data Sheet. Lit. Number DS60001579
- SAM9X60 SiP Data Sheet. Lit. Number DS60001580

2. Product Overview

The SAM9X60-Curiosity follows the Microchip MPU strategy for low-cost evaluation kits, showcasing all the features that the SAM9X60D1G MPU can offer.

2.1 SAM9X60-Curiosity Features

Table 2-1. SAM9X60-Curiosity Features

Characteristic	Specification	Featured Components
Processor	233-ball TFBGA, 14x14 mm, 0.8 mm pitch	Microchip SAM9X60D1G-I / 4FB
External clock	24 MHz Oscillator MEMS	DSC6102HI2B-024.0000T
	32.768 KHz Crystal	FC-12M 32.7680KA-A3
	25 MHz Clock generator for ETH PHY	DSC6102HI2B-025.000
Memory	1 Gb DDR2	Internal Memory
	One 4 Gb NAND Flash	Macronix MX30LF4G28AD-XKI
	One 2 Kb EEPROM	Microchip 24AA025E48
SD/MMC	One μ SD card interface	-
	One SD card / Radio Module interface	-
USB	One Micro-B USB device	Microchip MIC2026-1YM
	Two stacked USB Type-A connectors	
CAN	Two CAN interfaces	2 * Microchip MCP2542
Ethernet	One Ethernet 10/100	Microchip KSZ8081RNAIA-TR
	One RJ45 connector	
LCD	One LCD RGB666 interface	-
Debug port	One UART Debug connector	-
	One JTAG interface	-
Board monitor	One RGB (Red, Green, Blue) LED	-
	Three push button switches	-
Expansion	Raspberry Pi® 40-pin GPIO connector	Hundreds of possible Click™ extensions featuring Microchip functions inside
	One mikroBUS™ connector	
Power management	Power Supply Unit	Microchip MCP16501TA-E/RMB
Board supply	System 5 V _{DC} from USB A	-

Note: Raspberry Pi is a trademark of Raspberry Pi Trading.

2.2 Evaluation Kit Specifications

Table 2-2. Evaluation Kit Specifications

Characteristic	Specification
Board Identification	SAM9X60-Curiosity
Board Supply Voltage	USB powered
Temperature	Operating: -40°C to +85°C
Relative Humidity	0 to 90% (non-condensing)
Main board dimensions	115 mm × 85 mm x 17.1 mm
RoHS Status	RoHS 3 Compliant
China RoHS Status	EFUP50
REACH Status	REACH Compliant

2.3 Power Sources

One option is available to power up the SAM9X60-Curiosity board:

- Powering through the USB Micro-B connector on the USBA port (J1)

Table 2-3. Electrical Characteristics

Electrical Parameters	Value
Input voltage	5 V _{DC}
Maximum input voltage (limits)	6 V _{DC}
Maximum 3.3 V _{DC} current	300 mA

 The SAM9X60-Curiosity board runs at a 3.3V voltage level logic. The maximum voltage that the I/O pins can tolerate is 3.3V. Providing higher voltages (e.g., 5V) to an I/O pin could damage the board.

2.4 Connectors on Board

The fully-featured SAM9X60-Curiosity board integrates multiple peripherals and interface connectors, as shown in the following figure.

Figure 2-1. SAM9X60-Curiosity Connectors

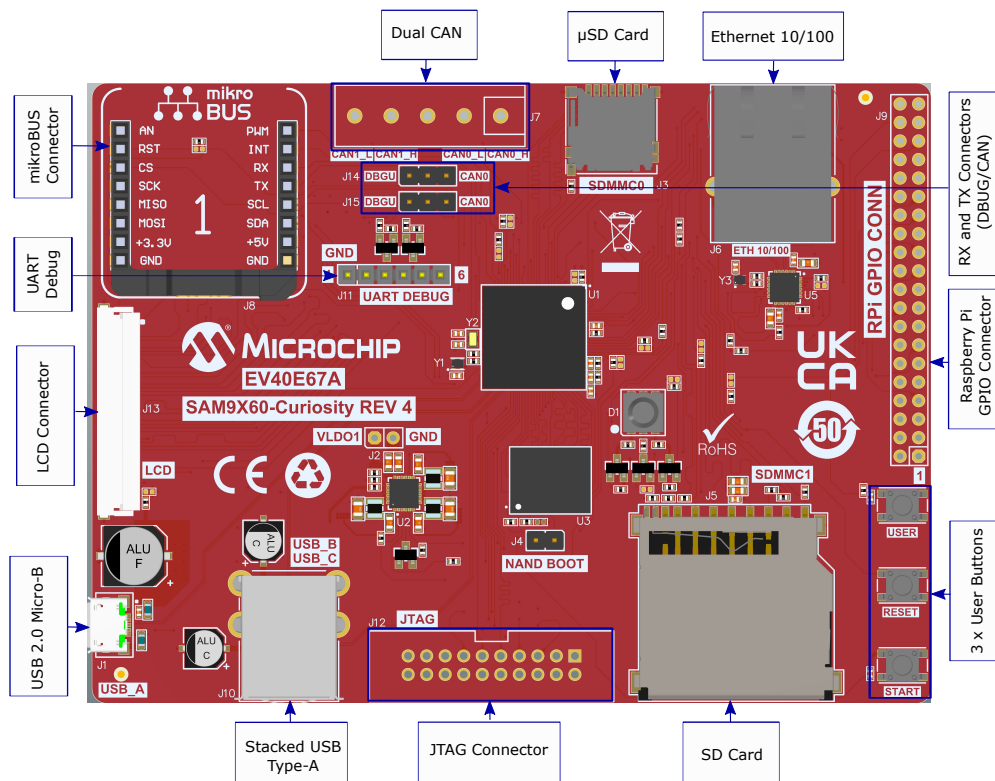

Table 2-4. SAM9X60-Curiosity Board Interface Connectors

Connector	Interfaces to
J1	USB 2.0 Micro-B (USB-A)
J3	μSD-CARD connector
J5	SD Card / Radio module connector
J6	Ethernet 10/100 RJ45 (port 1)
J7	Dual CAN (DNP)
J8	mikroBUS connector
J9	Raspberry Pi GPIO connector (DNP)
J10A	Stacked USB Type-A (USB-B)
J10B	Stacked USB Type-A (USB-C)
J11	FTDI connector (UART debugger)
J12	JTAG connector (DNP)
J13	LCD connector
J14	RX connector (Debug/CAN0)
J15	TX connector (Debug/CAN0)

2.5 Default Jumper Settings

Table 2-5. SAM9X60-Curiosity Jumper Settings

Jumper	Default Setting	Function
J4	Closed	NAND BOOT: <ul style="list-style-type: none"> • Opened: Disable BOOT • Closed: Enable BOOT
J14	1-2	RX Selection: <ul style="list-style-type: none"> • 1-2: DEBUG RX • 2-3: CAN0 RX
J15	1-2	TX Selection: <ul style="list-style-type: none"> • 1-2: DEBUG TX • 2-3: CAN0 TX

2.6 Kit Content

The SAM9X60-Curiosity kit includes the following:

- The SAM9X60-Curiosity board inside an ESD bag
- One USB-A to USB Micro-B cable

3. Function Blocks

This section covers the specifications of the SAM9X60-Curiosity and provides a high-level description of the board's major components and interfaces. This document is not intended to provide detailed documentation about the processor or about any other component used on the board. It is expected that the user will refer to the appropriate documents of these devices to access detailed information.

Figure 3-1. SAM9X60-Curiosity Block Diagram

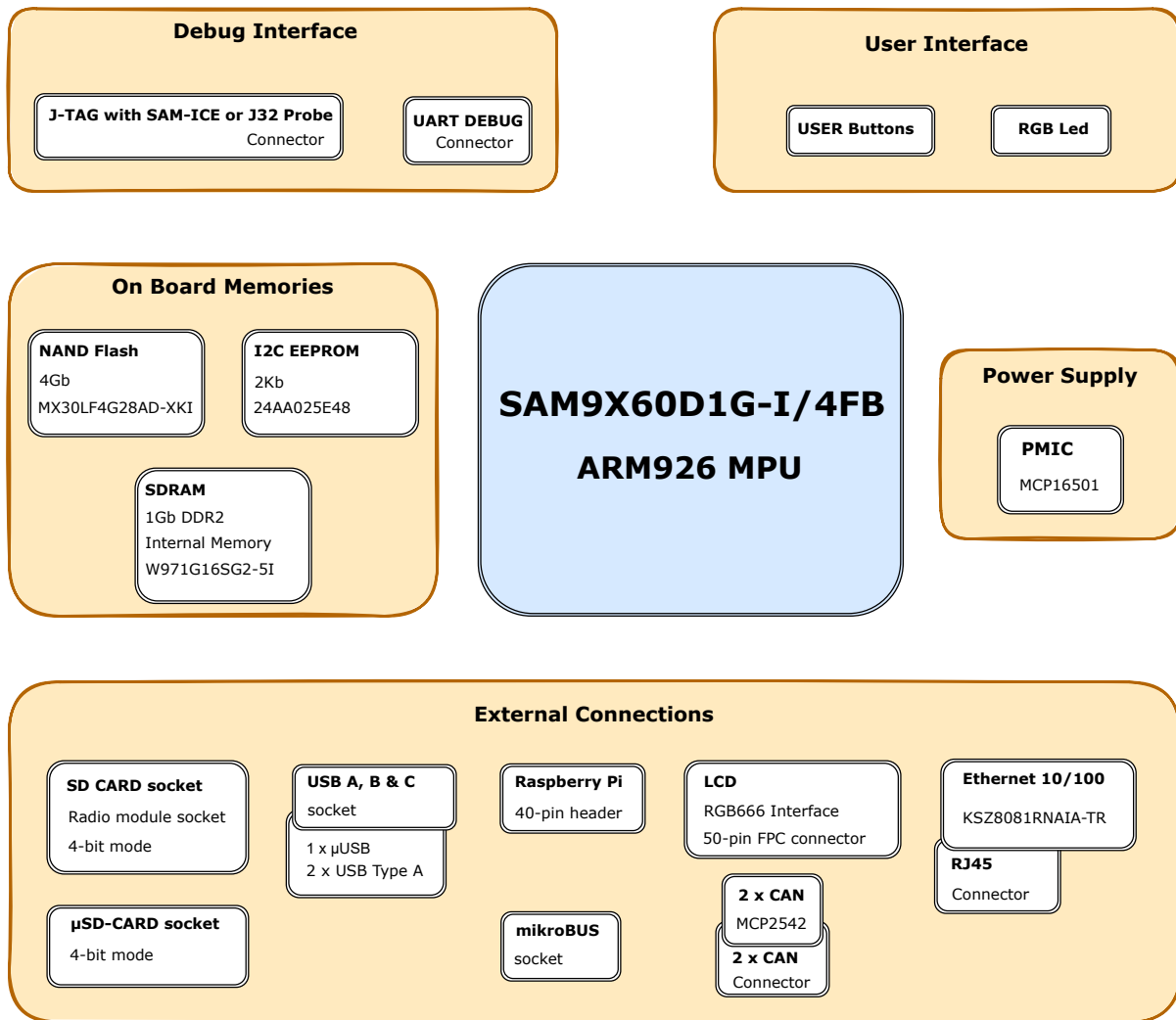

3.1 Power Supply Topology and Power Distribution

This section describes the implementation and the circuitry that ensures adequate voltage stability and current budget for all the devices on the board and a correct power-up sequence for the MPU. The power-up and power-down sequences indicated in the [SAM9X60 Data Sheet](#) must be respected for a reliable operation of the device.

3.1.1 Input Power Options

The SAM9X60-Curiosity board can be powered through:

- USB port A (J1)

The USB-powered operation comes from the USB device port connected to a PC or a 5 V_{DC} supply. The USB supply is enough to power the board in most applications. It is important to note that when the USB supply is used, the USB port has limited power.

The following figure shows the input power supply topology.

Figure 3-2. Input Power Option

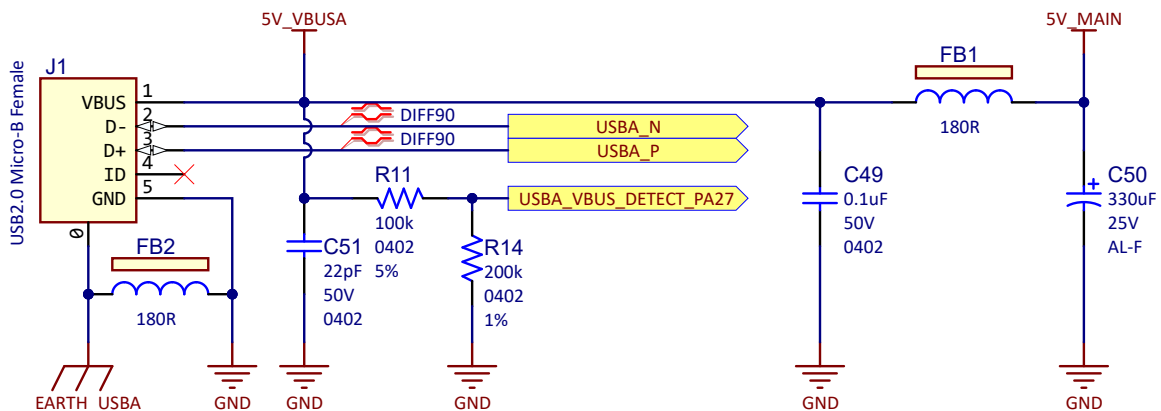

Note: USB-powered operation eliminates additional wires and batteries. It is the preferred mode of operation for any project that requires only a 5V source at up to 500 mA.

3.1.2 Power Management Integrated Circuit

The MCP16501 is a high-performance power management IC providing three output voltages with maximum efficiency, compatible with Microchip's eMPUs (Embedded Microprocessor Units) and associated DRAM memories. It is compatible with SAMA5D2, SAM9X6 and SAMA7G MPUs, which are supported by dedicated variants.

The MCP16501 integrates three DC-DC Buck regulators and one auxiliary LDO, and provides a comprehensive interface to the MPU.

All Buck channels can support loads up to 1A and are 100% duty cycle-capable.

For more information about the MCP16501, refer to the product [web page](#).

Detailed information on the SAM9X60D1G MPU power supplies and power-up/down considerations are described in section "Electrical Characteristics" in the [SAM9X60 Data Sheet](#).

The MCP16501 comes preset to supply all the voltage rails needed by the system:

- 1.8V supplies SAM9X60D1G DDR2 pads (VDDIOM) and devices.
- 1.15V supplies SAM9X60D1G Core (VDDCORE).
- 3.3V supplies SAM9X60D1G I/O pads.

The figure below shows the power management scheme.

Figure 3-3. Power Management Integrated Circuit

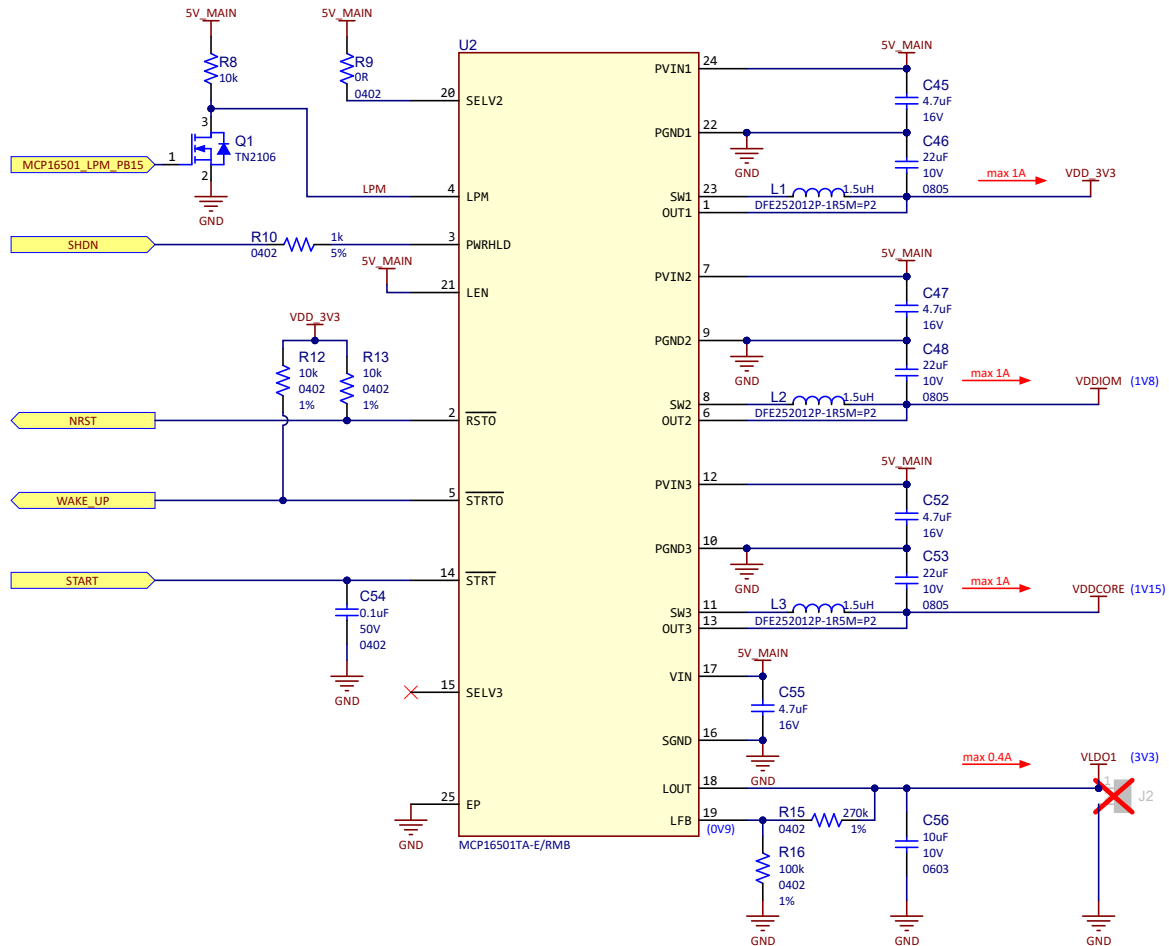

3.2 Processor

The SAM9X60D1G is a high-performance, ultra-low power ARM926EJ-S CPU-based embedded microprocessor (MPU) running up to 600 MHz, with an integrated 1 Gbit DDR2 memory. The device integrates powerful peripherals for connectivity and user interface applications, and offers security functions (tamper detection, etc.), TRNG, as well as high-performance crypto accelerators for AES and SHA.

Refer to the [SAM9X60 Data Sheet](#) for more information.

3.2.1 Power Supply

The PMIC (main regulator) provides all power supplies required by the SAM9X60D1G device:

- 1.15V for VDDCORE
- 1.8V for VDDIOM
- 3.3V for VDDIOP0, VDDIOP1, VDDIOQSPI, VDDUTMII, VDDPLLA, VDDANA, VDDOSC, VDDNF and VDDBU

Decoupling capacitors are placed close to the MPU power pins to stabilize the voltage rails.

Figure 3-4. Processor Power Supplies

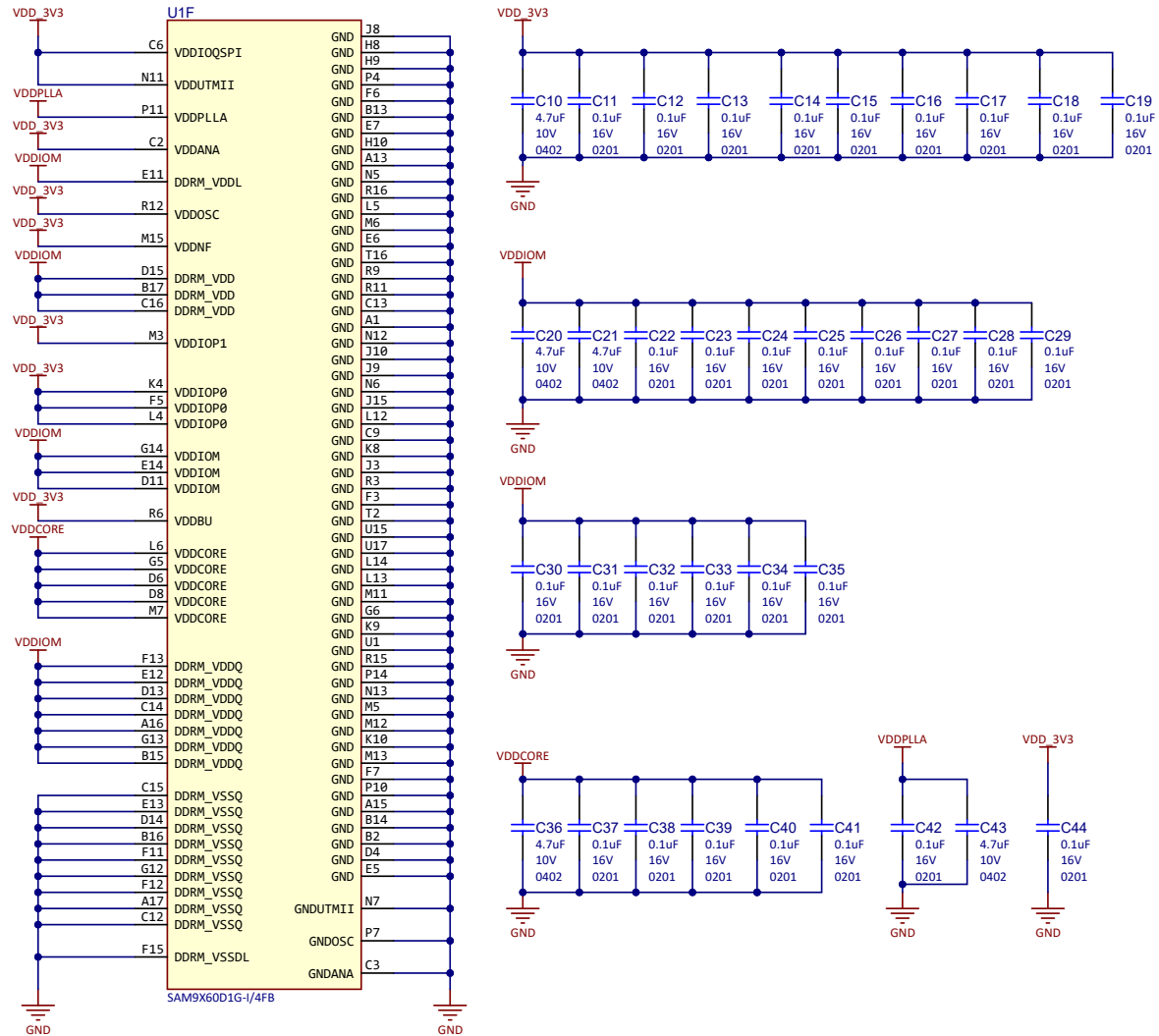

3.2.2 Main Configuration and Control

This block depicts the main block for processor configuration and control:

- XIN and XOUT are the Main Clock Oscillator input/output.
- XIN32 and XOUT32 are the Slow Clock Oscillator input/output.
- SHDN is an output signal used to enable and disable an external power supply circuit.
- WKUP is an event detection input pin used to wake up the processor from Shutdown state.
- JTAGSEL is an input that when pulled high enables the JTAG boundary scan.
- TCK, TDI, TDO, TMS and RTCK are used for JTAG communication.
- NRST is the processor main reset input.
- HSD_A/B/C are the three USB ports embedded inside the MPU.
- RTUNE is used for USB external tuning.
- TST input is reserved for processor manufacturing tests.
- ADVREFP and ADVREFN are the positive and negative reference points for the Analog to Digital Converter. A small low-pass filter is placed to reduce the input noise and improve accuracy.
- DDR_VREF pin serves as a voltage reference input for the DDR I/Os.

- DDRCAL is used to calibrate all DDR I/Os.

Figure 3-5. Processor Main Configuration and Control

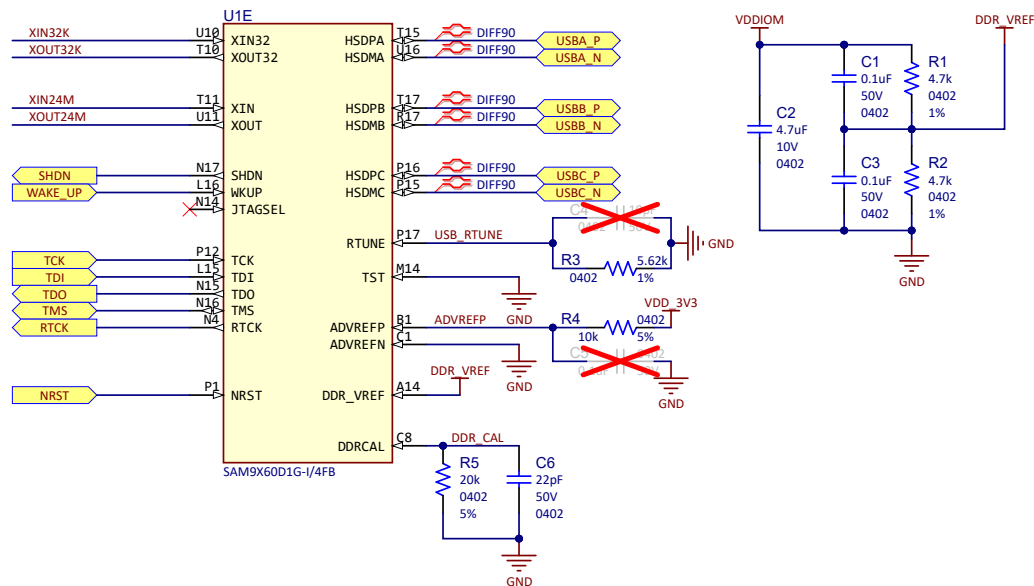

3.2.3 Clock Circuitry

The embedded MPU generates its necessary clocks based on two oscillators: one slow clock (SLCK) oscillator running at 32.768 kHz and one main clock oscillator running at 24 MHz.

The main clock oscillator is implemented with a MEMS (Micro Electro-Mechanical System) device DSC6102.

Figure 3-6. Processor Clock Circuitry

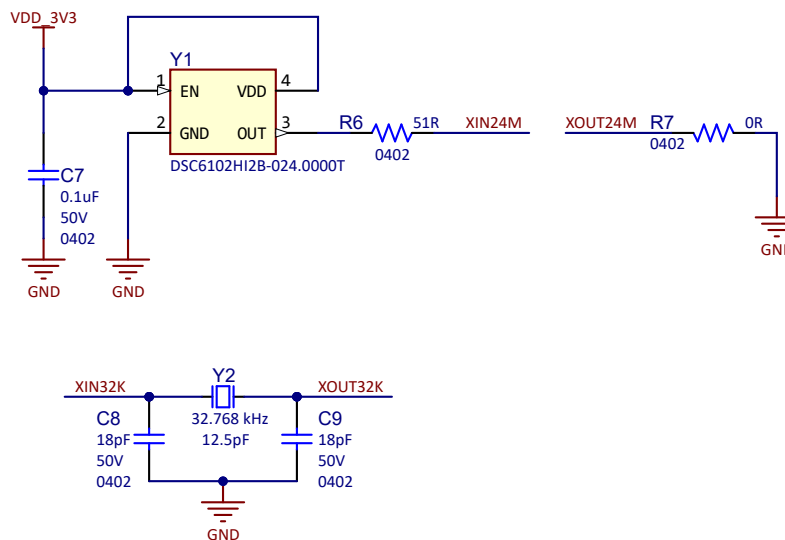

3.2.4 Reset Circuitry

Three reset sources for the SAM9X60D1G MPU are placed on the board:

- Power-on Reset from the power management unit MCP16501
- User push button reset SW1
- External JTAG reset

3.2.5 PIOs

The following sections depict all the signals connected to the SAM9X60D1G MPU ports.

See [Table 3-1](#) for details about each port's functions.

Figure 3-7. Processor PIOs PA and PC

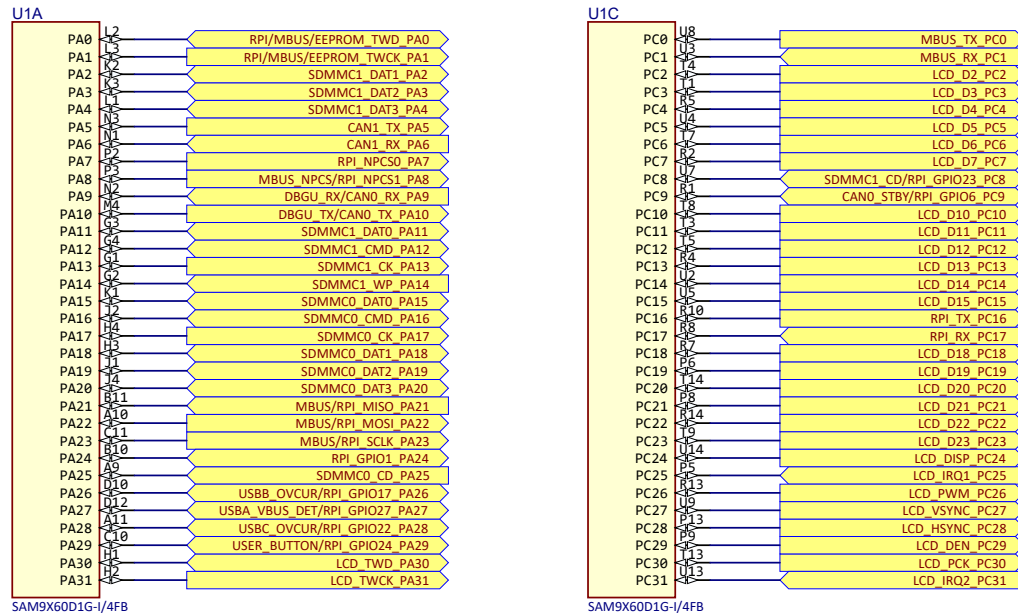
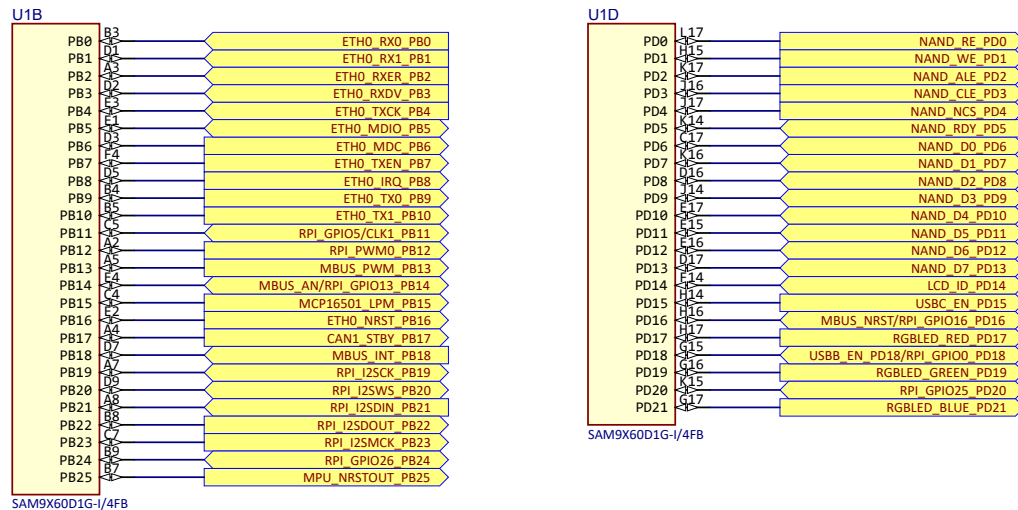

Figure 3-8. Processor PIOs PB and PD



Some of the ports were multiplexed to accommodate more devices on the evaluation kit and to showcase all the functions the SAM9X60D1G MPU can address off a single PIO wire.

Most of the ports that share multiple functions are split through passive resistors placed on the board as close to the MPU as possible, therefore no other hardware change must be made. In most cases, the user can use only one of their functions at a time, or can develop a composite driver enabling the use of multiple functions at the same time.

Figure 3-9. Processor PIO Muxing

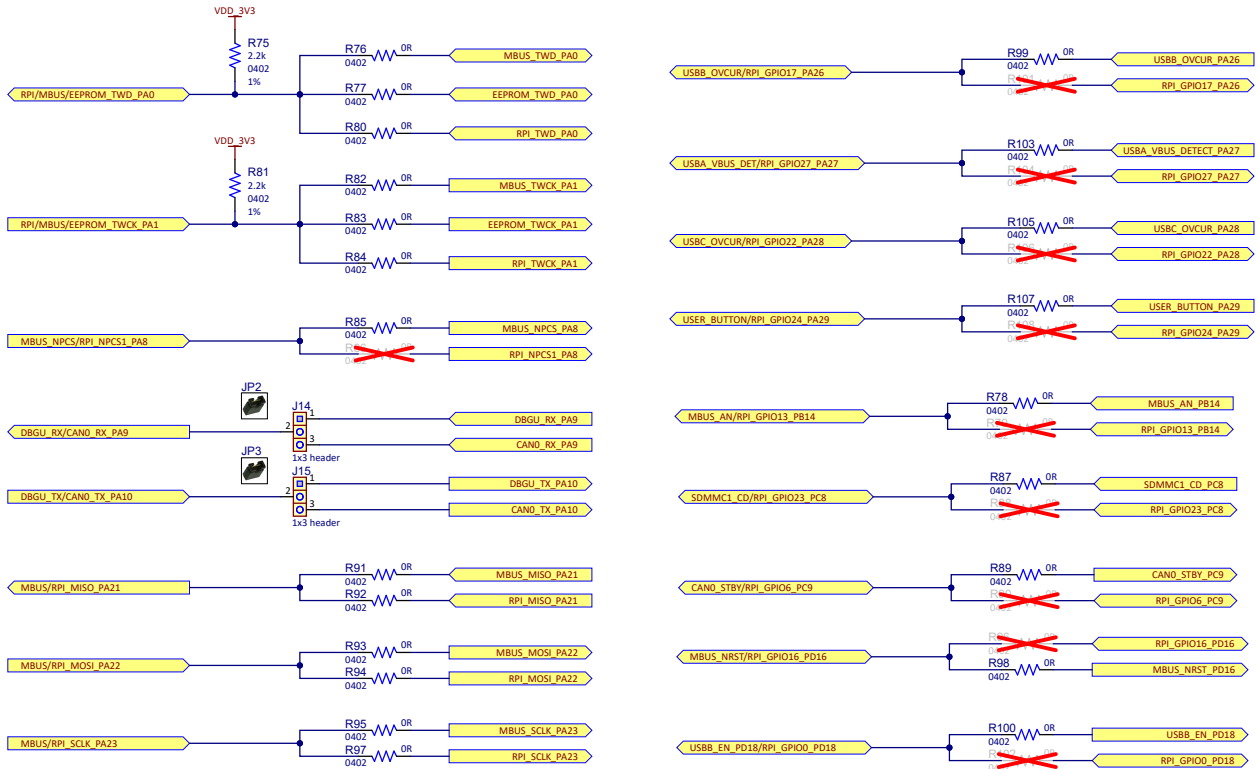

Table 3-1. Processor PIOs Pin Assignment and Signal Description

Pad	Power Rail	Function	I/O Type
PA0	VDD_3V3	MBUS_TWD	TWI Data (TWD) bidirectional line shared between the mikroBUS, EEPROMs and external 40-pin connector
	VDD_3V3	EEPROM_TWD	
	VDD_3V3	RPI_TWD	
PA1	VDD_3V3	MBUS_TWCK	TWI Clock (TWCK) output line shared between the mikroBUS, EEPROMs and external 40-pin connector
	VDD_3V3	EEPROM_TWCK	
	VDD_3V3	RPI_TWCK	
PA2	VDD_3V3	SDMMC1_DAT1	Data 1 bidirectional line going to the SD card connector
PA3	VDD_3V3	SDMMC1_DAT2	Data 2 bidirectional line going to the SD card connector
PA4	VDD_3V3	SDMMC1_DAT3	Data 3 bidirectional line going to the SD card connector
PA5	VDD_3V3	CAN1_TX	CAN Transmit output line going to the second CAN transceiver MCP2542
PA6	VDD_3V3	CAN1_RX	CAN Receive input line going to the second CAN transceiver MCP2542
PA7	VDD_3V3	RPI_NPCS0	SPI Chip Select 0 output line for the external 40-pin connector
PA8	VDD_3V3	MBUS_NPCS	SPI Chip Select 0 output line for the mikroBUS connector
	VDD_3V3	RPI_NPCS1	SPI Chip Select 1 output line for the external 40-pin connector
PA9	VDD_3V3	DBGU_RX	DEBUG UART Receive (DRX) input line
	VDD_3V3	CAN0_RX	CAN Receive input line going to the first CAN transceiver MCP2542
PA10	VDD_3V3	DBGU_TX	DEBUG UART Transmit (DTX) output line
	VDD_3V3	CAN0_TX	CAN Transmit output line going to the first CAN transceiver MCP2542
PA11	VDD_3V3	SDMMC1_DAT0	Data 0 bidirectional line going to the SD card connector
PA12	VDD_3V3	SDMMC1_CMD	Command (CMD) bidirectional line going to the SD card connector
PA13	VDD_3V3	SDMMC1_CLK	Clock (CLK) output line going to the SD card connector
PA14	VDD_3V3	SDMMC1_WP	Write protect (WP) input line going to the SD card connector

.....continued

Pad	Power Rail	Function	I/O Type
PA15	VDD_3V3	SDMMC0_DAT0	Data 0 bidirectional line going to the μSD card connector
PA16	VDD_3V3	SDMMC0_CMD	Command (CMD) bidirectional line going to the μSD card connector
PA17	VDD_3V3	SDMMC0_CK	Clock (CLK) output line going to the μSD card connector
PA18	VDD_3V3	SDMMC0_DAT1	Data 1 bidirectional line going to the μSD card connector
PA19	VDD_3V3	SDMMC0_DAT2	Data 2 bidirectional line going to the μSD card connector
PA20	VDD_3V3	SDMMC0_DAT3	Data 3 bidirectional line going to the μSD card connector
PA21	VDD_3V3	MBUS_MISO	SPI Host Input Client Output (MISO) input line shared between the mikroBUS and external 40-pin connectors
	VDD_3V3	RPI_MISO	
PA22	VDD_3V3	MBUS_MOSI	SPI Host Output Client Input (MOSI) output line shared between the mikroBUS and external 40-pin connectors
	VDD_3V3	RPI_MOSI	
PA23	VDD_3V3	MBUS_SCLK	SPI Clock (SCLK) output line shared between the mikroBUS and external 40-pin connectors
	VDD_3V3	RPI_SCLK	
PA24	VDD_3V3	RPI_GPIO1	GPIO going to the external 40-pin connector
PA25	VDD_3V3	SDMMC0_CD	Card Detect input line going to the μSD card connector
PA26	VDD_3V3	USBV_OVCCR	USBV over current flag input
	VDD_3V3	RPI_GPIO17	GPIO going to the external 40-pin connector
PA27	VDD_3V3	USBA_VBUS_DETECT	USBA VBUS detect input
	VDD_3V3	RPI_GPIO27	GPIO going to the external 40-pin connector
PA28	VDD_3V3	USBC_OVCCR	USBC over current flag input
	VDD_3V3	RPI_GPIO22	GPIO going to the external 40-pin connector
PA29	VDD_3V3	USER_BUTTON	GPIO used as input to probe the changes of the user button
	VDD_3V3	RPI_GPIO24	GPIO going to the external 40-pin connector
PA30	VDD_3V3	LCD_TWD	TWI Data (TWD) bidirectional line going to the LCD connector
PA31	VDD_3V3	LCD_TWCK	TWI Clock (TWCK) output line going to the LCD connector
PB0	VDD_3V3	ETH0_RX0	RMII Ethernet Receive Data 0 signal going to KSZ8081
PB1	VDD_3V3	ETH0_RX1	RMII Ethernet Receive Data 1 signal going to KSZ8081
PB2	VDD_3V3	ETH0_RXER	RMII Ethernet Receive Error signal going to KSZ8081
PB3	VDD_3V3	ETH0_RXDV	RMII Ethernet Receive Data Valid signal going to KSZ8081
PB4	VDD_3V3	ETH0_TXCK	RMII Ethernet Transmit Clock signal going to KSZ8081
PB5	VDD_3V3	ETH0_MDIO	RMII Ethernet Management Data I/O signal going to KSZ8081
PB6	VDD_3V3	ETH0_MDC	RMII Ethernet Management Data Clock signal going to KSZ8081
PB7	VDD_3V3	ETH0_TXEN	RMII Ethernet Transmit Enable signal going to KSZ8081
PB8	VDD_3V3	ETH0_IRQ	RMII Ethernet Interrupt Request signal going to KSZ8081
PB9	VDD_3V3	ETH0_TX0	RMII Ethernet Transmit Data 0 signal going to KSZ8081
PB10	VDD_3V3	ETH0_TX1	RMII Ethernet Transmit Data 1 signal going to KSZ8081
PB11	VDD_3V3	RPI_GPIO5/CLK1	GPIO going to the external 40-pin connector / Clock 1
PB12	VDD_3V3	RPI_PWM0	PWM0 signal output line going to the external 40-pin connector
PB13	VDD_3V3	MBUS_PWM	PWM signal output line going to the mikroBUS connector
PB14	VDD_3V3	MBUS_AN	Analog input from the mikroBUS connector
	VDD_3V3	RPI_GPIO13	GPIO going to the external 40-pin connector
PB15	VDD_3V3	MCP16501_LPM	MCP16501 Low Power Mode selection output
PB16	VDD_3V3	ETH0_Nrst	RMII Ethernet Reset signal going to KSZ8081
PB17	VDD_3V3	CAN1_STBY	GPIO used as output to place the second CAN transceivers in or out of standby
PB18	VDD_3V3	MBUS_INT	GPIO input used to signal any interrupt request from the mikroBUS connector
PB19	VDD_3V3	RPI_I2SCK	I2S Clock signal going to the external 40-pin connector

.....continued

Pad	Power Rail	Function	I/O Type
PB20	VDD_3V3	RPI_I2SWS	I2S Word Select signal going to the external 40-pin connector
PB21	VDD_3V3	RPI_I2SDIN	I2S Data IN signal going to the external 40-pin connector
PB22	VDD_3V3	RPI_I2SDOUT	I2S Data Out signal going to the external 40-pin connector
PB23	VDD_3V3	RPI_I2SMCK	I2S Host Clock signal going to the external 40-pin connector
PB24	VDD_3V3	RPI_GPIO26	GPIO signal going to the external 40-pin connector
PB25	VDD_3V3	MPU_NRSTOUT	Output signal used to reset all the devices on the board
PC0	VDD_3V3	MBUS_TX	UART Transmit (TX) output line going to the mikroBUS connector
PC1	VDD_3V3	MBUS_RX	UART Receive (RX) input line going to the mikroBUS connector
PC2	VDD_3V3	LCD_D2	LCD Data Output 2 (DAT2) signal going to the LCD connector
PC3	VDD_3V3	LCD_D3	LCD Data Output 3 (DAT3) signal going to the LCD connector
PC4	VDD_3V3	LCD_D4	LCD Data Output 4 (DAT4) signal going to the LCD connector
PC5	VDD_3V3	LCD_D5	LCD Data Output 5 (DAT5) signal going to the LCD connector
PC6	VDD_3V3	LCD_D6	LCD Data Output 6 (DAT6) signal going to the LCD connector
PC7	VDD_3V3	LCD_D7	LCD Data Output 7 (DAT7) signal going to the LCD connector
PC8	VDD_3V3	SDMMC1_CD	Card Detect signal going to the SD card connector
	VDD_3V3	RPI_GPIO23	GPIO going to the external 40-pin connector
PC9	VDD_3V3	CAN0_STBY	GPIO used as output to place the first CAN transceivers in or out of standby
	VDD_3V3	RPI_GPIO6	GPIO going to the external 40-pin connector
PC10	VDD_3V3	LCD_D10	LCD Data Output 10 (DAT10) signal going to the LCD connector
PC11	VDD_3V3	LCD_D11	LCD Data Output 11 (DAT11) signal going to the LCD connector
PC12	VDD_3V3	LCD_D12	LCD Data Output 12 (DAT12) signal going to the LCD connector
PC13	VDD_3V3	LCD_D13	LCD Data Output 13 (DAT13) signal going to the LCD connector
PC14	VDD_3V3	LCD_D14	LCD Data Output 14 (DAT14) signal going to the LCD connector
PC15	VDD_3V3	LCD_D15	LCD Data Output 15 (DAT15) signal going to the LCD connector
PC16	VDD_3V3	RPI_TX	UART Transmit output line going to the external 40-pin connector
PC17	VDD_3V3	RPI_RX	UART Receive input line going to the external 40-pin connector
PC18	VDD_3V3	LCD_D18	LCD Data Output 18 (DAT18) signal going to the LCD connector
PC19	VDD_3V3	LCD_D19	LCD Data Output 19 (DAT19) signal going to the LCD connector
PC20	VDD_3V3	LCD_D20	LCD Data Output 20 (DAT20) signal going to the LCD connector
PC21	VDD_3V3	LCD_D21	LCD Data Output 21 (DAT21) signal going to the LCD connector
PC22	VDD_3V3	LCD_D22	LCD Data Output 22 (DAT22) signal going to the LCD connector
PC23	VDD_3V3	LCD_D23	LCD Data Output 23 (DAT23) signal going to the LCD connector
PC24	VDD_3V3	LCD_DISP	LCD Display ON/OFF output signal going to the LCD connector
PC25	VDD_3V3	LCD_IRQ1	LCD maXTouch interrupt line
PC26	VDD_3V3	LCD_PWM	LCD PWM for Contrast Control output signal going to the LCD connector
PC27	VDD_3V3	LCD_VSYNC	LCD Vertical Synchronization output signal going to the LCD connector
PC28	VDD_3V3	LCD_HSYNC	LCD Horizontal Synchronization output signal going to the LCD connector
PC29	VDD_3V3	LCD_DEN	LCD Data Enable output signal going to the LCD connector
PC30	VDD_3V3	LCD_PCK	LCD Pixel Clock output signal going to the LCD connector
PC31	VDD_3V3	LCD_IRQ2	LCD Interrupt line for other I ² C devices
PD0	VDD_3V3	NAND_RE	NAND Flash Read Enable (RE) output signal going to MX30LF4G28AD-XKI
PD1	VDD_3V3	NAND_WE	NAND Flash Write Enable (OE) output signal going to MX30LF4G28AD-XKI
PD2	VDD_3V3	NAND_ALE	NAND Flash Address Latch Enable (ALE) output signal going to MX30LF4G28AD-XKI
PD3	VDD_3V3	NAND_CLE	NAND Flash Command Latch Enable (CLE) output signal going to MX30LF4G28AD-XKI

.....continued			
Pad	Power Rail	Function	I/O Type
PD4	VDD_3V3	NAND_NCS	NAND Flash Chip Select (CS) output signal going to MX30LF4G28AD-XKI
PD5	VDD_3V3	NAND_RDY	NAND Flash Ready/Busy (R/B#) input signal coming from MX30LF4G28AD-XKI
PD6	VDD_3V3	NAND_D0	NAND Flash Data 0 (D0) bidirectional signal going to MX30LF4G28AD-XKI
PD7	VDD_3V3	NAND_D1	NAND Flash Data 1 (D1) bidirectional signal going to MX30LF4G28AD-XKI
PD8	VDD_3V3	NAND_D2	NAND Flash Data 2 (D2) bidirectional signal going to MX30LF4G28AD-XKI
PD9	VDD_3V3	NAND_D3	NAND Flash Data 3 (D3) bidirectional signal going to MX30LF4G28AD-XKI
PD10	VDD_3V3	NAND_D4	NAND Flash Data 4 (D4) bidirectional signal going to MX30LF4G28AD-XKI
PD11	VDD_3V3	NAND_D5	NAND Flash Data 5 (D5) bidirectional signal going to MX30LF4G28AD-XKI
PD12	VDD_3V3	NAND_D6	NAND Flash Data 6 (D6) bidirectional signal going to MX30LF4G28AD-XKI
PD13	VDD_3V3	NAND_D7	NAND Flash Data 7 (D7) bidirectional signal going to MX30LF4G28AD-XKI
PD14	VDD_3V3	LCD_ID	ID LCD module
PD15	VDD_3V3	USBC_EN	Power delivery enable signal for USBC host interface
PD16	VDD_3V3	MBUS_NRST	Reset signal for the mikroBUS connector
	VDD_3V3	RPI_GPIO16	GPIO going to the external 40-pin connector
PD17	VDD_3V3	RGBLED_RED	D1 red LED
PD18	VDD_3V3	USBB_EN	Power delivery enable signal for USBB host interface
	VDD_3V3	RPI_GPIO0	GPIO going to the external 40-pin connector
PD19	VDD_3V3	RGBLED_GREEN	D1 green LED
PD20	VDD_3V3	RPI_GPIO25	GPIO going to the external 40-pin connector
PD21	VDD_3V3	RGBLED_BLUE	D1 blue LED

3.3 On-board Memories

The SAM9X60D1G features a DDR/SDR memory interface and an External Bus Interface (EBI) to enable interfacing to a wide range of external memories and to almost any type of parallel peripheral.

This section describes the memory devices mounted on the SAM9X60-Curiosity board:

- One DDR2 SDRAM
- One NAND Flash
- One serial EEPROM

Additional memory can be added to the board by:

- Installing an SD or MMC card in the SD/MMC slot,
- Installing a μ SD or MMC card in the SD/MMC slot,
- Using the USB ports.

Support is dependent upon driver support in the OS.

3.3.1 DDR2/SDRAM

SAM9X60D1G-I/4FB features an internal 16-bit DRAM Data bus, 1-Gbit DDR2 SDRAM memory . Refer to the SAM9X60 SiP Data Sheet for details, available on www.microchip.com/.

3.3.2 NAND Flash

The SAM9X60-Curiosity has native support for NAND Flash memory through its NAND Flash Controller. The board implements one MX30LF4G28AD 4 Gb (512M x 8) NAND Flash connected to Chip Select of the microprocessor.

Figure 3-10. NAND Flash

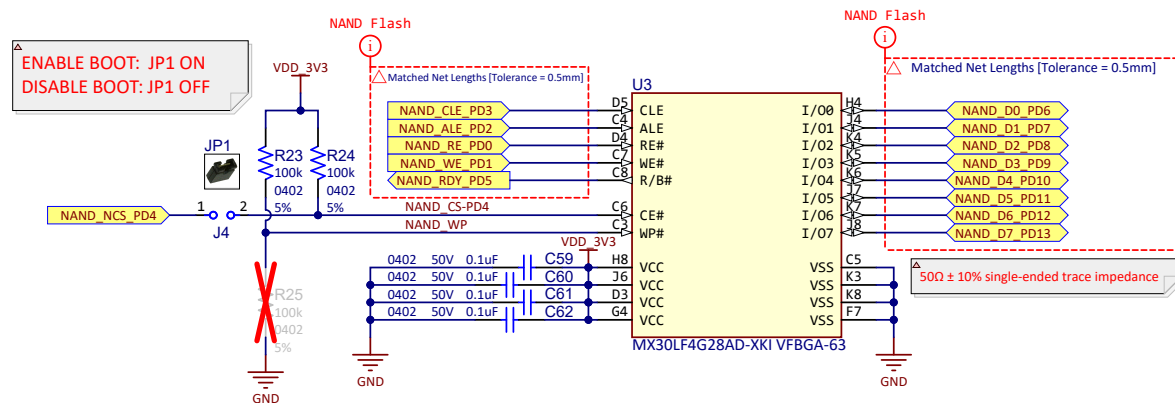

Table 3-2. NAND Flash Signal Descriptions

PIO	Signal Name	Signal Description
PD6	NAND_D0_PD6	Data 0
PD7	NAND_D1_PD7	Data 1
PD8	NAND_D2_PD8	Data 2
PD9	NAND_D3_PD9	Data 3
PD10	NAND_D4_PD10	Data 4
PD11	NAND_D5_PD11	Data 5
PD12	NAND_D6_PD12	Data 6
PD13	NAND_D7_PD13	Data 7
PD3	NAND_CLE_PD3	Command Latch Enable
PD2	NAND_ALE_PD2	Address Latch Enable
PD0	NAND_RE_PD0	Read Enable
PD1	NAND_WE_PD1	Write Enable
PD5	NAND_RDY_PD5	Ready/Busy#
PD4	NAND_NCS_PD4	Chip Select

3.3.3 Serial EEPROM with Unique MAC Address

The SAM9X60-Curiosity board embeds one Microchip 24AA025E48 serial EEPROM. The 24AA025E48 features 2048 bits of serial Electrically-Erasable Programmable Read-Only Memory (EEPROM) organized as 256 words of eight bits each and is accessed via an I²C-compatible (2-wire) serial interface. In addition, the 24AA025E48 incorporates an easy and inexpensive method to obtain a globally unique MAC or EUI address (EUI-48™). For more information about the 24AA025E48, refer to the product [web page](#).

The EUI-48 addresses can be assigned as the actual physical address of a system hardware device or node, or it can be assigned to a software instance. These addresses are factory-programmed by

Microchip and unique. They are permanently write-protected in an extended memory block located outside the standard 2-Kbit memory array.

Figure 3-11. EEPROM 24AA025E48

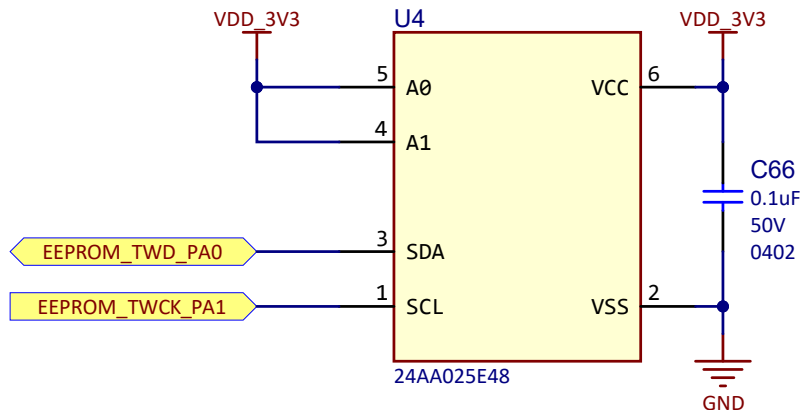

Table 3-3. EEPROM PIO Signal Descriptions

PIO	Signal Name	Shared PIO	Signal Description
PA0	EEPROM_TWD_PA0	TWI and SPI	TWI data
PA1	EEPROM_TWCK_PA1	TWI and SPI	TWI clock

In the SAM9X60-Curiosity usage context, the EEPROM device is used as a “software label” to store board information such as chip type, manufacturer name and production date, using the last two 16-byte blocks in memory. The information contained in these blocks should not be modified.

3.4 Peripherals

Several interfaces and connectors are implemented in the SAM9X60-Curiosity with the purpose of enabling the user to test all the features that the MPU can offer and to facilitate a reference design for future customer applications.

This section describes the following peripherals mounted on the SAM9X60-Curiosity board:

- [3.4.1. Ethernet 10/100 Port \(GMAC\)](#)
- [3.4.2. USB Host/Device](#)
- [3.4.3. Controller Area Network \(CAN\) Interface](#)
- [3.4.4. Liquid Crystal Display \(LCD\) Interface](#)
- [3.4.5. Secure Digital Multimedia Cards \(SDMMC\)](#)
- [3.4.6. mikroBUS Interface](#)
- [3.4.7. GPIO Interface](#)

3.4.1 Ethernet 10/100 Port (GMAC)

The KSZ8081 is a single-supply 10Base-T/100Base-TX Ethernet physical-layer transceiver for transmission and reception of data over standard CAT-5 unshielded twisted pair (UTP) cable. The KSZ8081 is a highly-integrated PHY solution. It reduces board cost and simplifies board layout by using on-chip termination resistors for the differential pairs and by integrating a low-noise regulator to supply the 1.2V core, and by offering 1.8/2.5/3.3V digital I/O interface support.

The KSZ8081RNA is connected over the Reduced Media Independent Interface (RMII) directly to the RMII-compliant MAC inside the SAM9X60D1G MPU. As the power-up default, the KSZ8081RNA uses a 25 MHz MEMS oscillator to generate all required clocks, including the 50-MHz RMII reference clock output for the MAC. For more information about the KSZ8081RNx, refer to the product [web page](#).

An individual unique 48-bit MAC address (Ethernet hardware address) is allocated to this product and is stored in the Microchip 24AA025E48 TWI serial EEPROM described in 3.3.3. [Serial EEPROM with Unique MAC Address](#).

Additionally, for monitoring and control purposes, an LED functionality is carried on the RJ45 connectors to indicate activity, link, and speed status.

Figure 3-12. Ethernet Interface

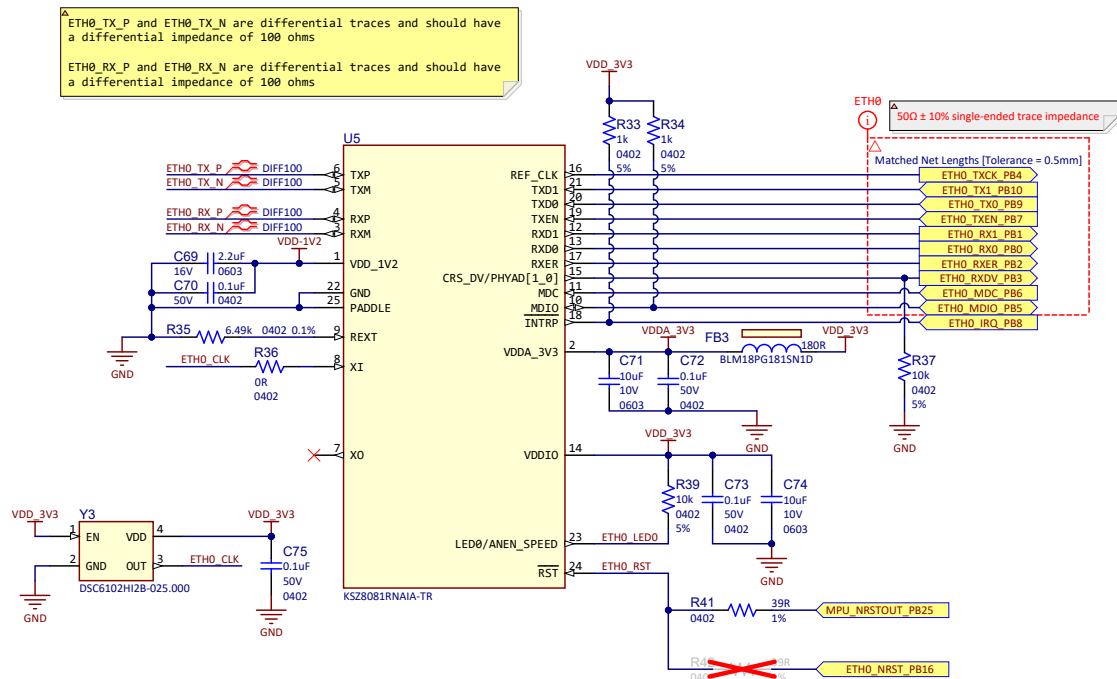

Table 3-4. Ethernet PHY 10/100 Signal Descriptions

PIO	Signal Name	Signal Description
PB4	ETH0_TXCK_PB4	Transmit clock
PB10	ETH0_TX1_PB10	Transmit data 1
PB9	ETH0_TX0_PB9	Transmit data 0
PB7	ETH0_TXEN_PB7	Transmit enable
PB1	ETH0_RX1_PB1	Receive data 1
PB0	ETH0_RX0_PB0	Receive data 0
PB2	ETH0_RXER_PB2	Receive error
PB3	ETH0_RXDV_PB3	Receive data valid
PB6	ETH0_MDC_PB6	Management data clock
PB5	ETH0_MDIO_PB5	Management data in/out
PB8	ETH0_IRQ_PB8	Interrupt request
PB25	MPU_NRSTOUT_PB25	Module reset
PB16	ETH0_NRST_PB16	Reset

Figure 3-13. Ethernet PHY Connector

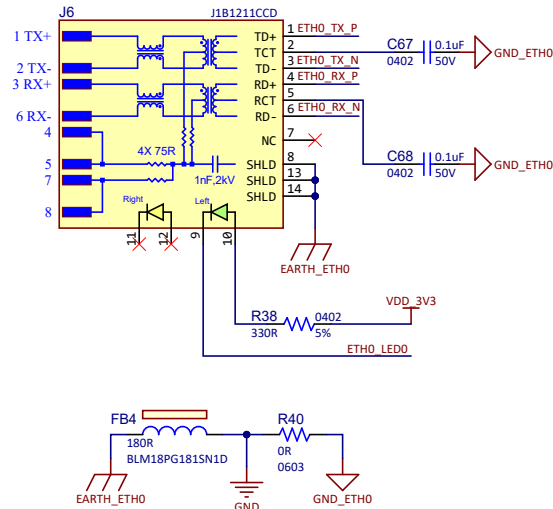

Table 3-5. Ethernet RJ45 Connector J6 Pin Assignment

Pin No	Signal Name	Signal Description
1	TD+	Transmit
2	TCT	-
3	TD-	Transmit
4	RD+	Receive
5	RCT	-
6	RD-	Receive
7	NC	-
8	EARTH / GND	Common ground
9	Left LED	LED green
10	Left LED	LED green
11	Right LED	LED yellow
12	Right LED	LED yellow
13	EARTH / GND	Common ground
14	EARTH / GND	Common ground

3.4.2 USB Host/Device

The USB (Universal Serial Bus) is a hot-pluggable general-purpose high-speed I/O standard for computer peripherals. The standard defines connector types, cabling, and communication protocols for interconnecting a wide variety of electronic devices. The USB 2.0 Specification defines data transfer rates as high as 480 Mbps (also known as High Speed USB). A USB host bus connector uses four pins: a power supply pin (5V), a differential pair (D+ and D- pins) and a ground pin.

The SAM9X60-Curiosity board features three USB communication ports named USB-A to USB-C™.

The USB-A port can act only as a USB device interface and can be accessed via the USB Micro-B connector (J1).

Two resistors are placed on its power rail to form a voltage divider, converting 5V into 3.3V that is then used to signal the presence of a USB host to the MPU.

The USB-A port is used as a power source, as mentioned in 3.1. [Power Supply Topology and Power Distribution](#). In most cases, this port is limited to 500 mA.

In the case of board bring-up, USB-A is the default port used to connect the MPU over SAM-BA (SAM Boot Assistance). For more information, refer to the product [web page](#).

Figure 3-14. USB-A Port

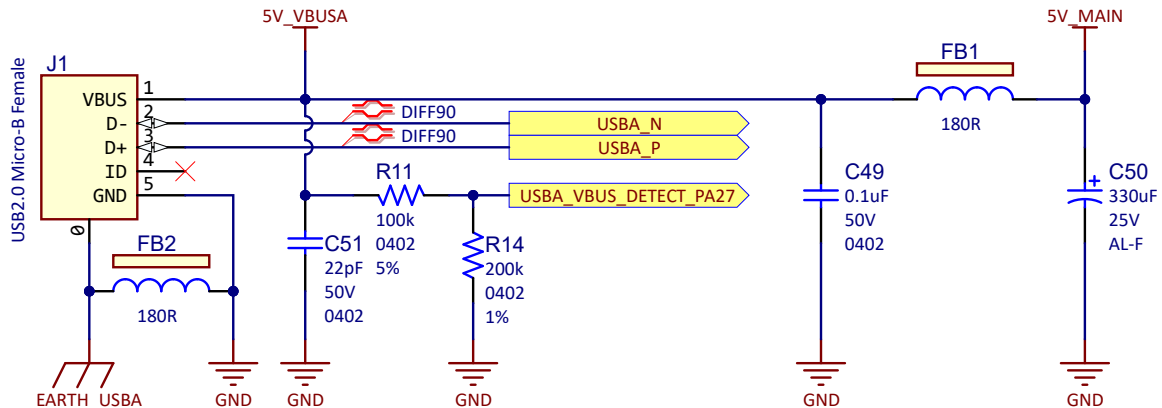

Table 3-6. USB-A Connector Signal Descriptions

Pin No	Signal Name	Signal Description
1	5V_VBUSA	First port 5V power
2	USBA_N	First port data minus
3	USBA_P	First port data plus
4	ID	– (not used)
5	GND	First port ground

Table 3-7. USB-A PIO Signal Descriptions

PIO	Signal Name	Signal Description
PA27	USBA_VBUS_DETECT_PA27	VBUS detection

The USB-B and USB-C ports are connected to the stacked USB Type-A connector (J10) and each port can act both as device and as host.

Figure 3-15. USB-B and USB-C Ports

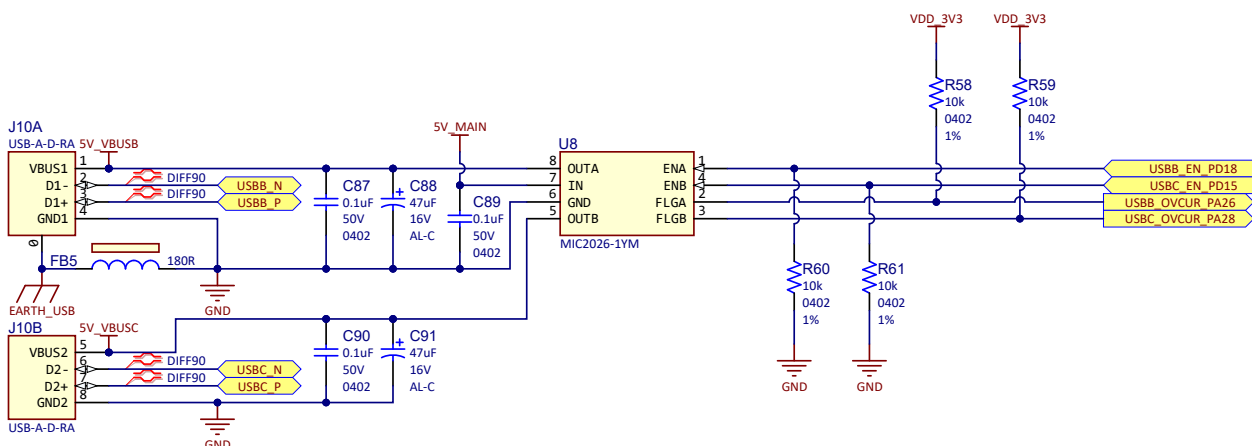

Table 3-8. USB-B and USB-C Connector Signal Descriptions

Pin No	Signal Name	Signal Description
0	EARTH_USB	Connector chassis connected to ground
1	5V_VBUSB	Second port 5V power

.....continued

Pin No	Signal Name	Signal Description
2	USBB_N	Second port data minus
3	USBB_P	Second port data plus
4	GND	Second port ground
5	5V_VBUS	Third port 5V power
6	USBC_N	Third port data minus
7	USBC_P	Third port data plus
8	GND	Third port ground

In Host mode, the USB Host ports B and C are equipped with 500 mA high-side power switches to enable self-powered and bus-powered applications. The USBx_EN_PDxx signal controls the current limiting power switch MIC2026, which in turn supplies power to a client device. Per the USB specification, bus-powered USB 2.0 devices are limited to a maximum of 500 mA, therefore the MIC2026 limits the current and indicates an overcurrent with the USBx_OVCUR_PAx signal. For more information about the MIC2026, refer to the product [web page](#).

Table 3-9. USB Power Switch PIO Signal Descriptions

PIO	Signal Name	Signal Description
PD18	USBB_EN_PD18	Power switch enable (active high)
PA26	USBB_OVCUR_PA26	Indicates overcurrent (open drain)
PD15	USBC_EN_PD15	Power switch enable (active high)
PA28	USBC_OVCUR_PA28	Indicates overcurrent (open drain)

3.4.3 Controller Area Network (CAN) Interface

Two MCP2542 transceivers are placed on the SAM9X60-Curiosity.

The MCP2542 is a high-speed CAN transceiver that provides the interface between the Controller Area Network (CAN) protocol controller and the physical two-wire bus. For more information about the MCP2542, refer to the product [web page](#).

Figure 3-16. Dual CAN Interface

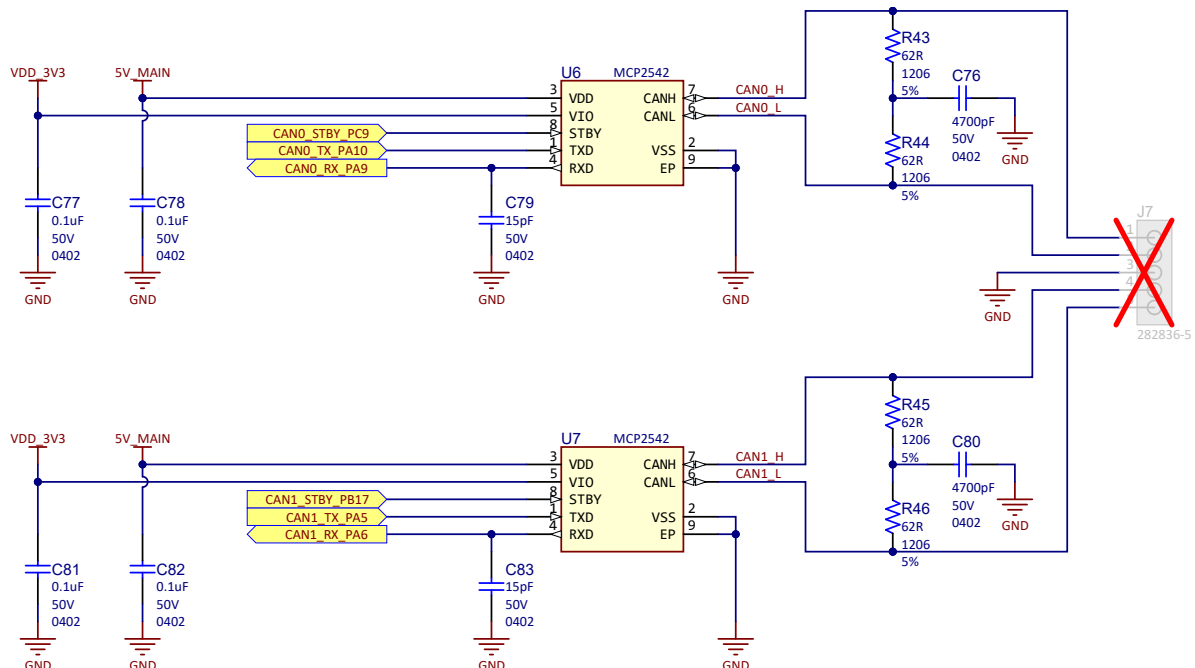

Table 3-10. CAN Signal Descriptions

PIO	Signal Name	Signal Description
PC9	CAN0_STBY_PC9	CAN standby port 0
PA10	CAN0_TX_PA10	CAN transmit port 0
PA9	CAN0_RX_PA9	CAN receive port 0
PB17	CAN1_STBY_PB17	CAN standby port 1
PA5	CAN1_TX_PA5	CAN transmit port 1
PA6	CAN1_RX_PA6	CAN receive port 1

CAN0 function and Debug UART (RX) are shared and selectable through the J14 connector.

CAN0 function and Debug UART (TX) are shared and selectable through the J15 connector.

Table 3-11. CAN Connector J7 Signal Description

Pin No	Signal Name	Signal Description
1	CAN0_H	Differential positive port 0
2	CAN0_L	Differential negative port 0
3	GND	Common ground
4	CAN1_H	Differential positive port 1
5	CAN1_L	Differential negative port 1



Attention: CAN connector (J7) is not assembled in the board.

3.4.4 Liquid Crystal Display (LCD) Interface

The SAM9X60-Curiosity board provides a connector with 24 bits of data and control signals to the LCD interface.

Optional displays such as AC320005-5 (refer to the product [web page](#)) can be connected to the board.

In order to operate correctly with various LCD modules, two power supplies are available: 3.3V and 5 V_{DC} (default). The selection is made with OR resistors.

J13 is a 1.27-mm pitch, 50-pin header. It gives access to the LCD signals.

Figure 3-17. LCD Connector

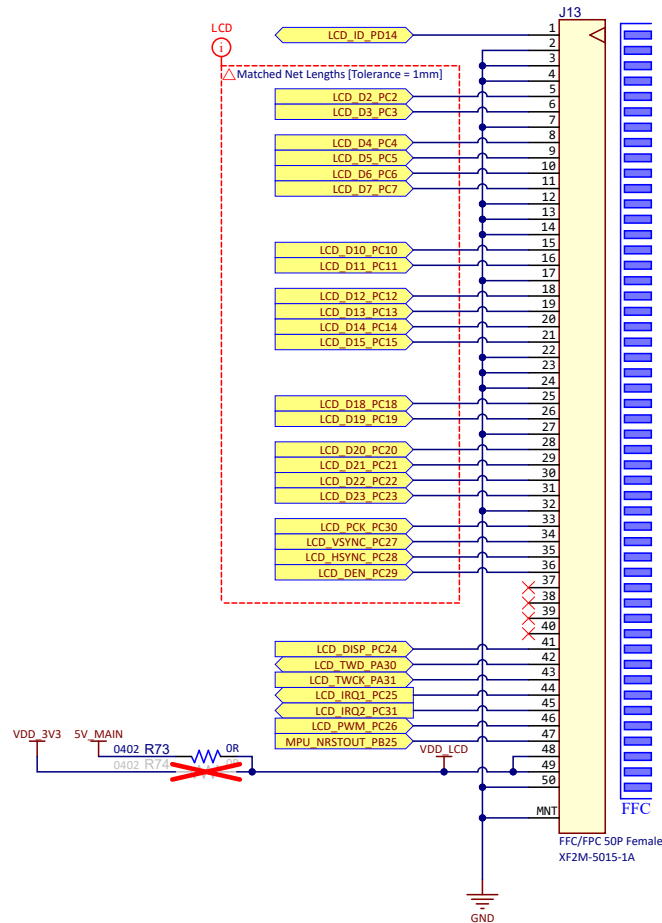

Table 3-12. LCD Connector J13 Signal Descriptions

Pin No	LCD pin	PIO	Signal	Function
1	ID	PD14	LCD_ID_PD14	ID LCD module
2	GND	-	GND	Ground
3	GND	-	GND	Ground
4	GND	-	GND	Ground
5	LCDDAT2	PC2	LCD_D2_PC2	Data line
6	LCDDAT3	PC3	LCD_D3_PC3	Data line
7	GND	-	GND	Ground
8	LCDDAT4	PC4	LCD_D4_PC4	Data line
9	LCDDAT5	PC5	LCD_D5_PC5	Data line
10	LCDDAT6	PC6	LCD_D6_PC6	Data line
11	LCDDAT7	PC7	LCD_D7_PC7	Data line
12	GND	-	GND	Ground
13	GND	-	GND	Ground
14	GND	-	GND	Ground
15	LCDDAT10	PC10	LCD_D10_PC10	Data line
16	LCDDAT11	PC11	LCD_D11_PC11	Data line
17	GND	-	GND	Ground
18	LCDDAT12	PC12	LCD_D12_PC12	Data line

.....continued				
Pin No	LCD pin	PIO	Signal	Function
19	LCDDAT13	PC13	LCD_D13_PC13	Data line
20	LCDDAT14	PC14	LCD_D14_PC14	Data line
21	LCDDAT15	PC15	LCD_D15_PC15	Data line
22	GND	-	GND	Ground
23	GND	-	GND	Ground
24	GND	-	GND	Ground
25	LCDDAT18	PC18	LCD_D18_PC18	Data line
26	LCDDAT19	PC19	LCD_D19_PC19	Data line
27	GND	-	GND	Ground
28	LCDDAT20	PC20	LCD_D20_PC20	Data line
29	LCDDAT21	PC21	LCD_D21_PC21	Data line
30	LCDDAT22	PC22	LCD_D22_PC22	Data line
31	LCDDAT23	PC23	LCD_D23_PC23	Data line
32	GND	-	GND	Ground
33	LCDPCK	PC30	LCD_PCK_PC30	Pixel clock
34	LCDVSYNC	PC27	LCD_VSYNC_PC27	Vertical synchronization
35	LCDHSYNC	PC28	LCD_HSYNC_PC28	Horizontal synchronization
36	LCDDEN	PC29	LCD_DEN_PC29	Data enable
37	-	-	NC	Not connected
38	-	-	NC	Not connected
39	-	-	NC	Not connected
40	-	-	NC	Not connected
41	LCDDISP	PC24	LCD_DISP_PC24	Display enable signal
42	TWD	PA30	LCD_TWD_PA30	I ² C data line (maXTouch)
43	TWCK	PA31	LCD_TWCK_PA31	I ² C clock line (maXTouch)
44	GPIO	PC25	LCD_IRQ1_PC25	maXTouch interrupt line
45	GPIO	PC31	LCD_IRQ2_PC31	Interrupt line for other I ² C devices
46	LCDPWM	PC26	LCD_PWM_PC26	Backlight control
47	RESET	PB25	MPU_NIRSTOUT_PB25	Reset for both display and maXTouch
48	3.3V/5V_MAIN	VDD	VDD	3.3V or 5V supply (0R)
49	3.3V/5V_MAIN	VDD	VDD	3.3V or 5V supply (0R)
50	GND	-	GND	Ground

3.4.5 Secure Digital Multimedia Cards (SDMMC)

The SD (Secure Digital) cards are a non-volatile memory card format used as a mass storage memory in mobile devices.

The SAM9X60D1G has two Secure Digital Multimedia Card (SDMMC) interfaces that support the MultiMedia Card (e.MMC) Specification V4.51, the SD Memory Card Specification V3.0, and the SDIO V3.0 specification. They are compliant with the SD Host Controller Standard V3.0 Specification.

A standard SD card connector, connected to the SDMMC interface, is mounted on the top side of the board. The SDMMC1 communication is based on an 8-pin interface (clock, command, four data and power lines). It includes a card detection switch. In addition, this interface has a write protect pin. The main purpose of this connector is to accommodate radio modules, such as the ATWILC3000-SD Evaluation Kit (AC164158). Details are available on the [Microchip web site](#).

Figure 3-18. SDMMC1 Connector

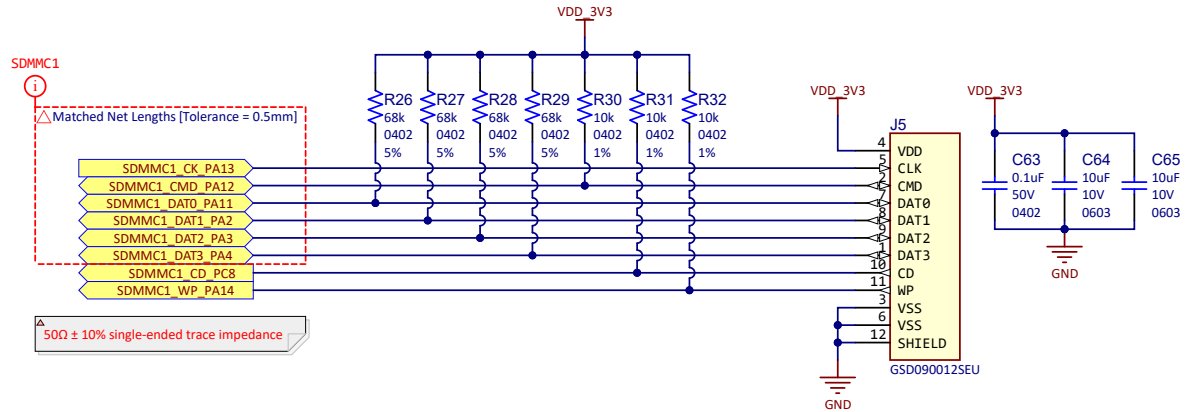

A standard μ SD card connector, connected to the SDMMC interface, is also mounted on the top side of the board. The SDMMC0 communication is based on an 8-pin interface (clock, command, four data and power lines). It includes a card detection switch. This connector gives access to the boot environment.

Figure 3-19. SDMMC0 Connector

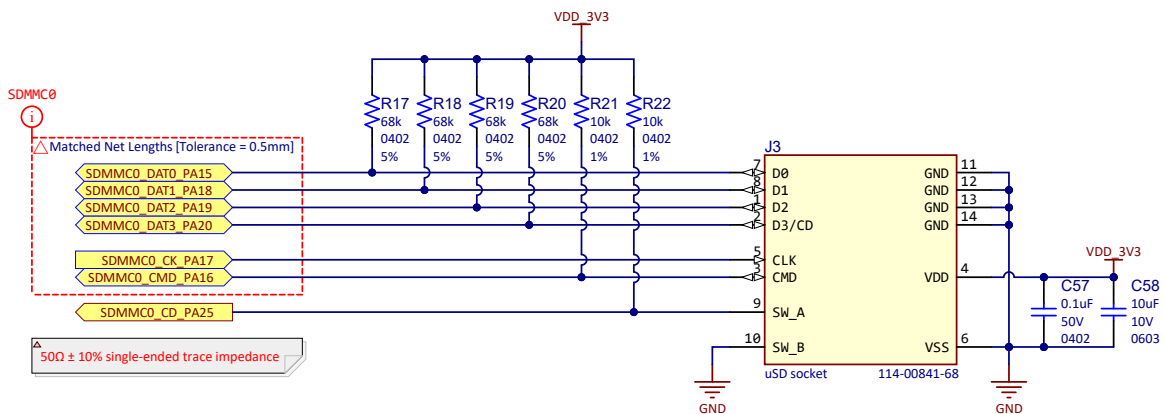

3.4.6 mikroBUS Interface

The SAM9X60-Curiosity hosts a mikroBUS socket (J8). The [mikroBUS standard](#) defines the main board sockets and add-on boards used for interfacing the microprocessor with integrated modules having a proprietary pin configuration. For details, refer to the mikroBUS documentation on [web page](#).

Figure 3-20. mikroBUS Interface

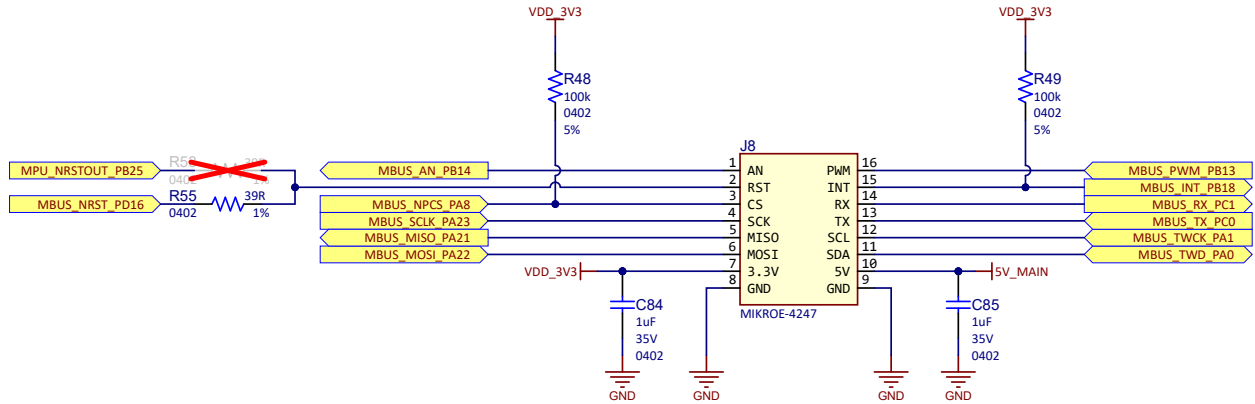

Table 3-13. mikroBUS Connector J8 Pin Assignment

Function	PIO	Mbus Signal	Pin #	Pin #	Mbus Signal	PIO	Function
Analog	PB14	AN	1	16	PWM	PB13	Pulse Width Modulated
Reset	PB25 o PD16	RST	2	15	INT	PB18	Interrupt
SPI Chip Select	PA8	CS	3	14	RX	PC1	UART receive (output from mikroBus into SAM)
SPI Clock	PA23	SCK	4	13	TX	PC0	UART transmit (input from SAM into mikroBus)
SPI MISO	PA21	MISO	5	12	SCL	PA1	TWI clock
SPI MOSI	PA22	MOSI	6	11	SDA	PA0	TWI data
VDD	-	3.3V	7	10	5V	-	VDD
Ground	-	GND	8	9	GND	-	Ground

3.4.7 GPIO Interface

The SAM9X60-Curiosity board features a 40-pin connector (Raspberry Pi-compatible) for free use.

Figure 3-21. GPIO Connector

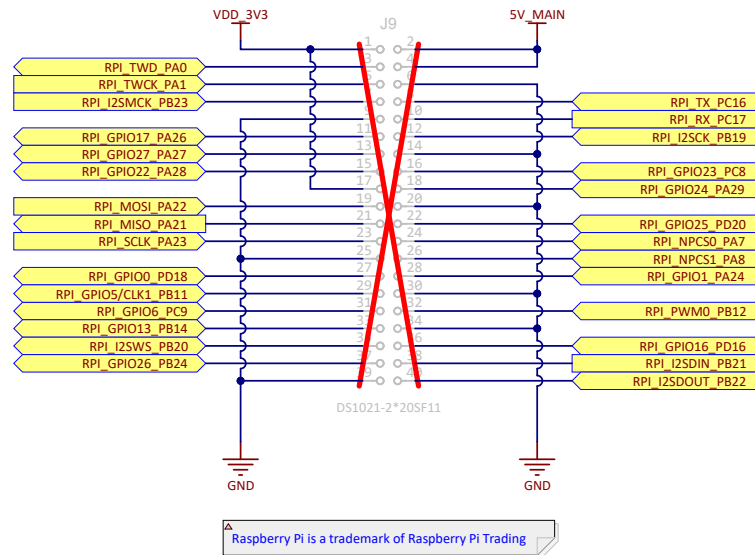

Table 3-14. GPIO Connector J9 Pin Assignment

Signal	Pin No	Pin No	Signal
VDD_3V3	1	2	5V_MAIN
RPI_TWD_PA0	3	4	5V_MAIN
RPI_TWCK_PA1	5	6	GND
RPI_I2SMCK_PB23	7	8	RPI_TX_PC16
GND	9	10	RPI_RX_PC17
RPI_GPIO17_PA26	11	12	RPI_I2SCK_PB19
RPI_GPIO27_PA27	13	14	GND
RPI_GPIO22_PA28	15	16	RPI_GPIO23_PC8
VDD_3V3	17	18	RPI_GPIO24_PA29
RPI_MOSI_PA22	19	20	GND
RPI_MISO_PA21	21	22	RPI_GPIO25_PD20
RPI_SCLK_PA23	23	24	RPI_NPCS0_PA7
GND	25	26	RPI_NPCS1_PA8
RPI_GPIO0_PD18	27	28	RPI_GPIO1_PA24
RPI_GPIO5/CLK1_PB11	29	30	GND
RPI_GPIO6_PC9	31	32	RPI_PWM0_PB12
RPI_GPIO13_PB14	33	34	GND
RPI_I2SWS_PB20	35	36	RPI_GPIO16_PD16
RPI_GPIO26_PB24	37	38	RPI_I2SDIN_PB21
GND	39	40	RPI_I2SDOUT_PB22



Attention: GPIO connector (J9) is not assembled on the board.

3.5 User Interaction and Debugging

The SAM9X60-Curiosity includes one main debugging interface to provide debug-level access to the SAM9X60-Curiosity:

- A JTAG interface connected directly to the MPU using connector J12 (DNP)

3.5.1 Serial Debug Com Port (FTDI)

The SAM9X60-Curiosity board features a dedicated serial port for debugging, accessible through header J11. Various interfaces can be used as a USB/Serial DBGU port bridge, such as the FTDI TTL-232R USB-to-TTL serial cable.

Figure 3-22. Serial Debug Com Port

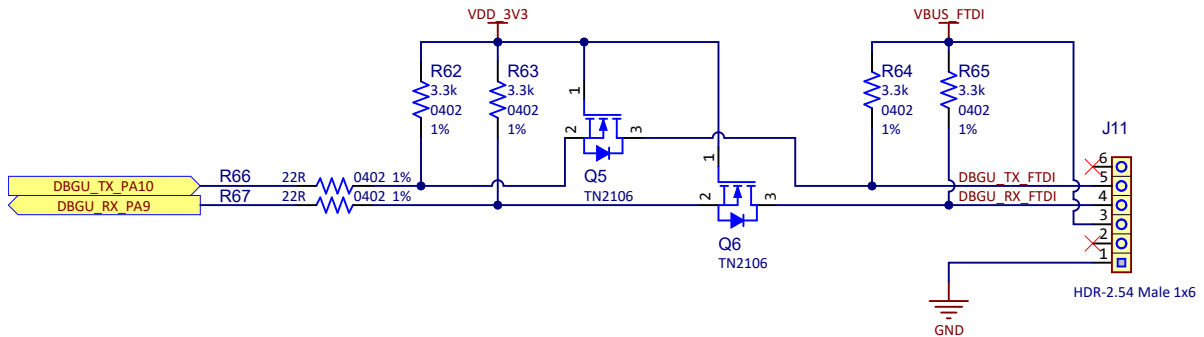

Table 3-15. Debug Com Port Signal Descriptions

PIO	Signal Name	Shared	Signal Description
PA9	DBGU_RX_PA9	DEBUG	Receive data
PA10	DBGU_TX_PA10	DEBUG	Transmit data

3.5.2 Debug JTAG

A 20-pin JTAG header (J12) is provided on the SAM9X60-Curiosity board to facilitate software development and debugging using various JTAG emulators. The interface signals have a voltage level of 3.3V.

Figure 3-23. JTAG Connector

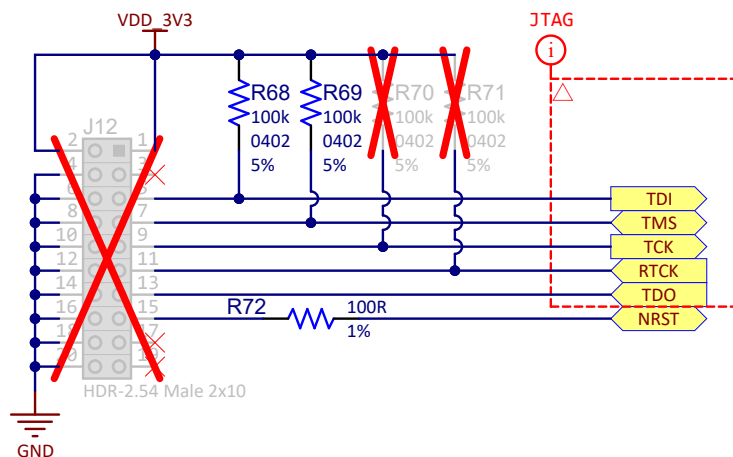

Table 3-16. JTAG/ICE Connector J23 Pin Assignment

Signal	Pin No	Pin No	Signal
VDD_3V3	2	1	VDD_3V3

.....continued

Signal	Pin No	Pin No	Signal
GND	4	3	NC
GND	6	5	TDI
GND	8	7	TMS
GND	10	9	TCK
GND	12	11	RTCK
GND	14	13	TDO
GND	16	15	NRST
GND	18	17	NC
GND	20	19	NC



Attention: JTAG connector (J12) is not assembled in the board.

3.5.3 Push Button Switches

The SAM9X60-Curiosity features three push buttons:

- One Board Reset push button (SW1); when pressed, the processor is reset.
- One User push button (SW2) connected to PIO_PA29. This is for user usage.
- One Start push button (SW3) connected to the MCP16501 pin. When pressed, the PMIC start-up sequence is initiated if the buck converters are off.

Figure 3-24. User Push Buttons

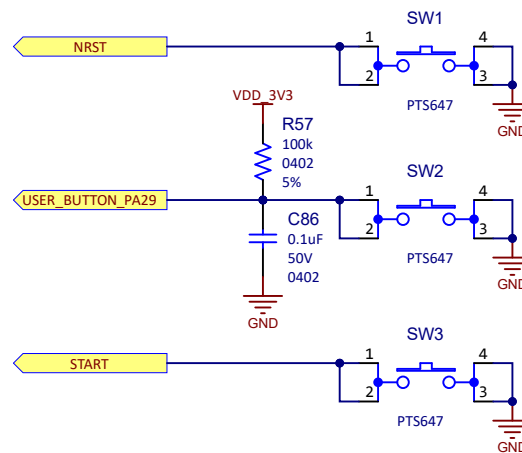

3.5.4 RGB LED

The SAM9X60-Curiosity board features one RGB LED. The three LED cathodes are controlled via GPIO PWM pins.

Figure 3-25. User LEDs

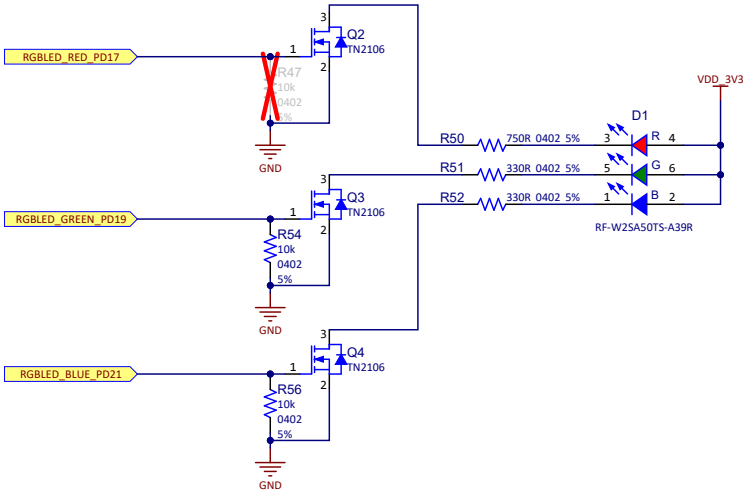

Table 3-17. RGB LED PIOs

Signal	PIO	Function
RGBLED_RED_PD17	PD17	Red LED
RGBLED_GREEN_PD19	PD19	Green LED
RGBLED_BLUE_PD21	PD21	Blue LED

4. Installation and Operation

4.1 System and Configuration Requirements

The SAM9X60-Curiosity requires the following:

- Personal computer
- USB cable (provided in the kit box)

4.2 Board Setup

Follow these steps before using the SAM9X60-Curiosity:

1. Unpack the board, taking care to avoid electrostatic discharge.
2. Check the default jumper settings (see [2.5. Default Jumper Settings](#)).
3. Connect the Micro-USB cable to connector J1 (USB-A port).
4. Connect the other end of the cable to a free port on your PC.
5. Connect a USB-UART converter to J11, making sure to also connect the VBUS_FTDI power source.
6. Open a terminal (console 115200, N, 8, 1) on your PC for the USB-UART converter.
7. Reset the board. A startup message appears on the console.

5. Ordering Information

Ordering Code	Board Marking
EV40E67A	SAM9X60-Curiosity

6. Errata

6.1 LCD Touchscreen Limitation

Due to missing on-board pull-up resistors on the I²C bus, the LCD touchscreen feature might not work properly with all displays.

Workaround

If higher speeds are required, add 3.3 kOhm pull-up resistors to VDD_3V3 on signals LCD_TWD_PA30 and LCD_TWCK_PA31.

7. Appendix. Schematics and Layouts

7.1 SAM9X60-Curiosity Schematics

This section contains the following schematics for the SAM9X60-Curiosity board:

- Block Diagram Schematic, [Figure 7-1](#)
- SAM9X60 SiP Schematic, [Figure 7-2](#)
- SAM9X60 SiP Power Schematic, [Figure 7-3](#)
- Power Management Schematic, [Figure 7-4](#)
- NAND Flash, SDMMCs and EEPROM Schematic, [Figure 7-5](#)
- Ethernet Schematic, [Figure 7-6](#)
- CAN Schematic, [Figure 7-7](#)
- User Interface Schematic, [Figure 7-8](#)
- USB Host Schematic, [Figure 7-9](#)
- Debug Interface and JTAG with SAM-ICE Schematic, [Figure 7-10](#)
- LCD RGB666 Interface Schematic, [Figure 7-11](#)
- PIO Muxing Schematic, [Figure 7-12](#)

Figure 7-1. Block Diagram Schematic

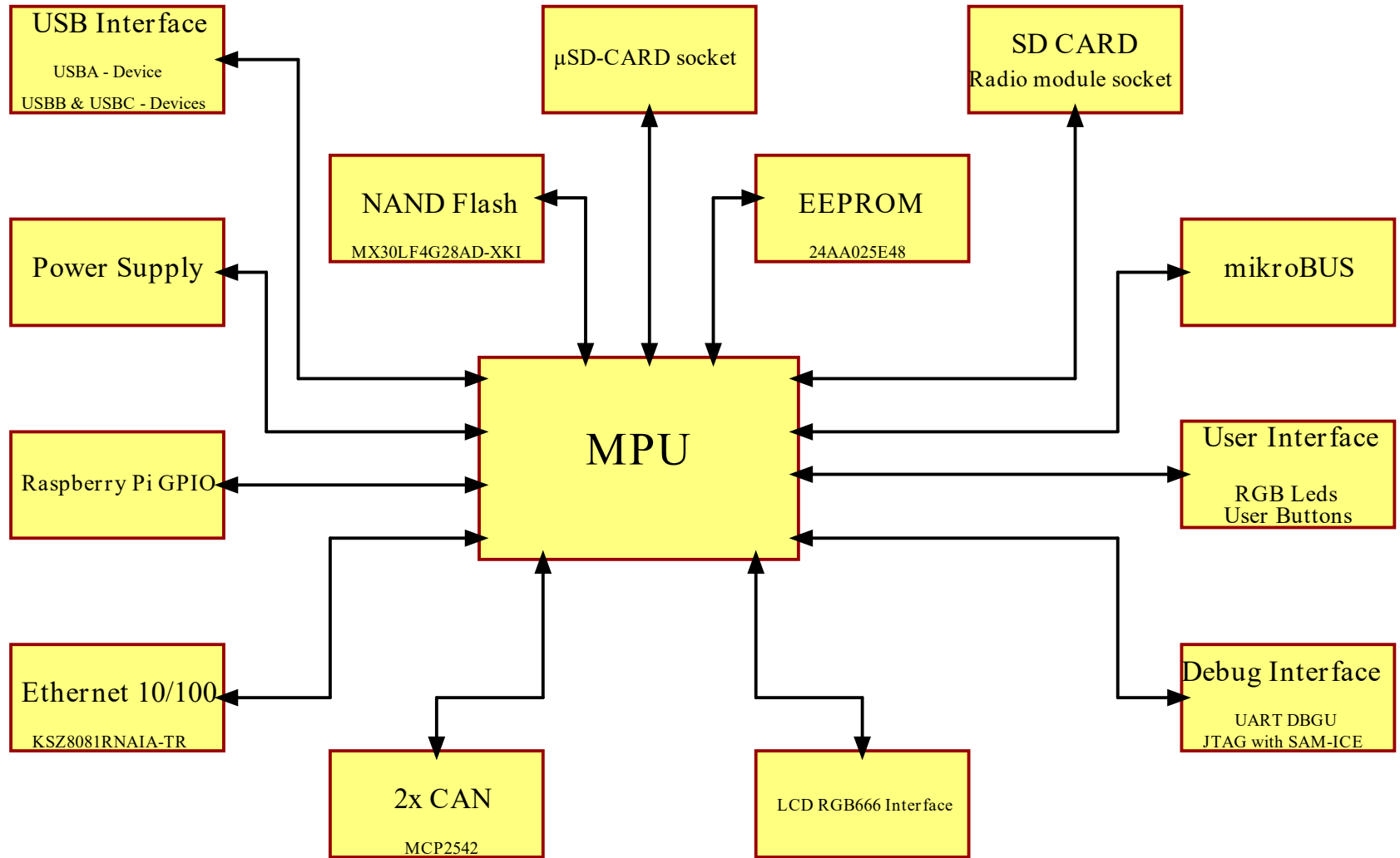

Figure 7-2. SAM9X60 SiP Schematic

SAM9X60 SiP

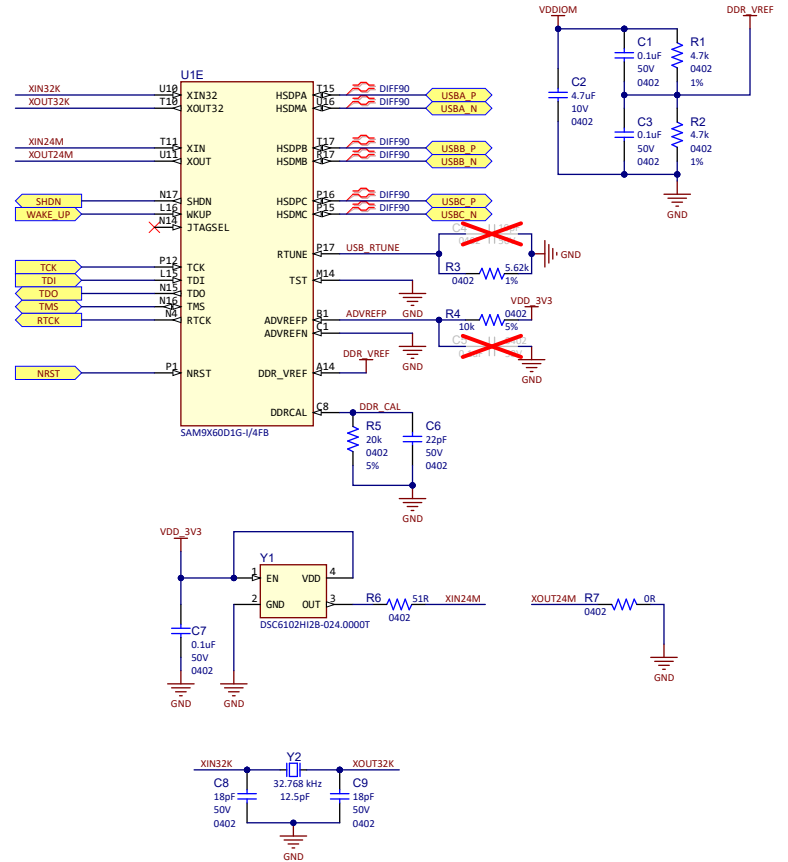
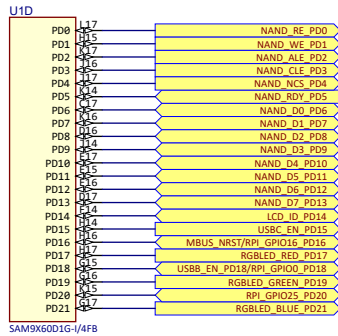
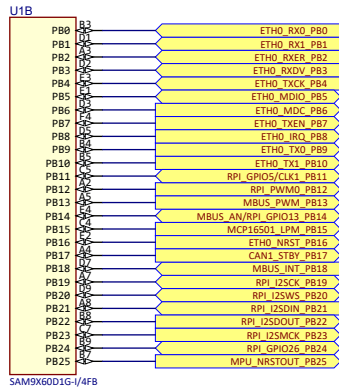
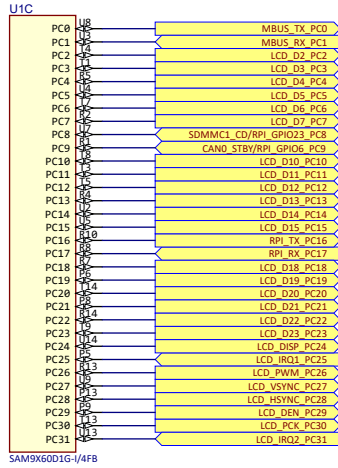
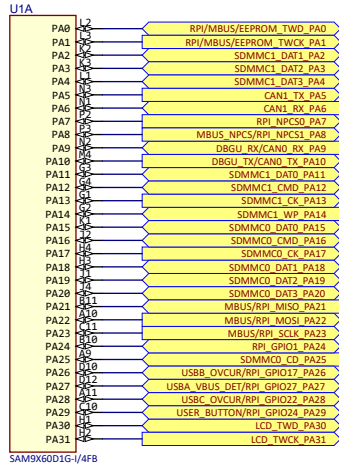

Figure 7-3. SAM9X60 SiP Power Schematic

SAM9X60 SiP Power

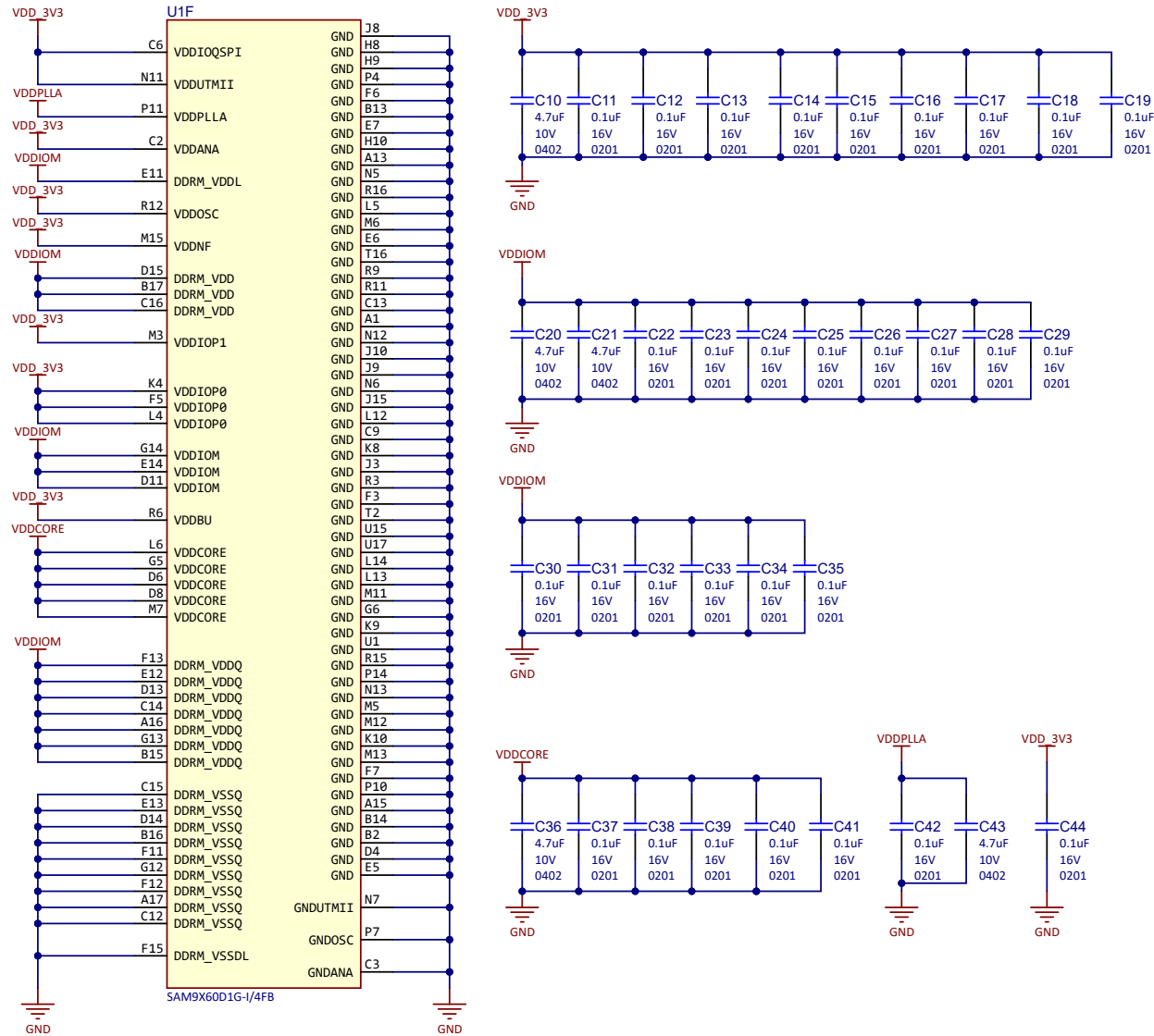

Figure 7-4. Power Management Schematic

Power Management

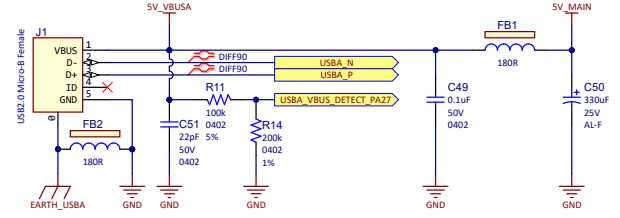
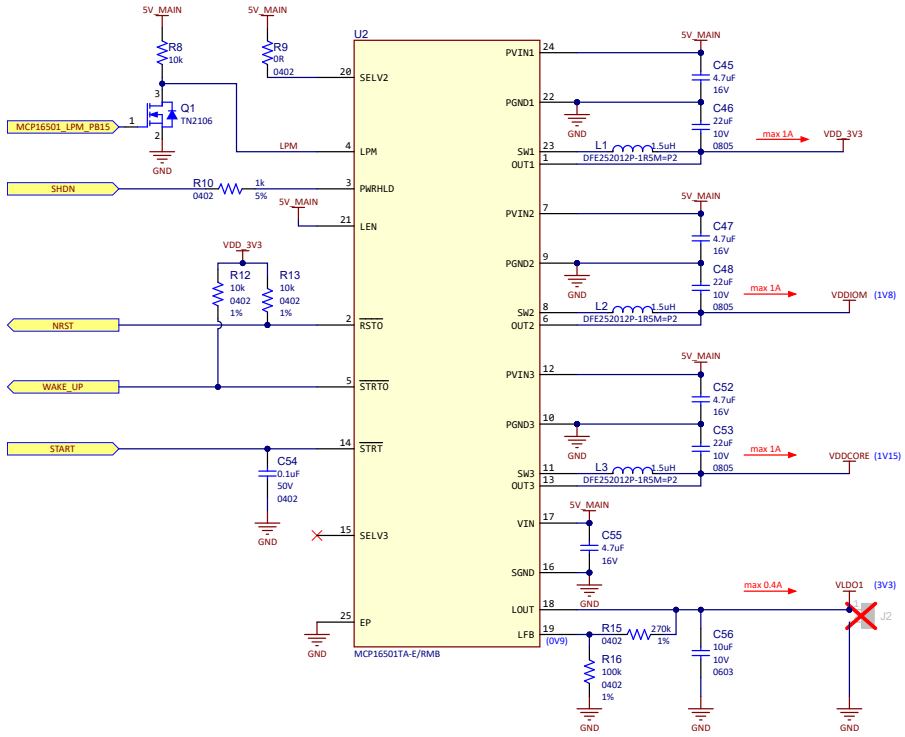
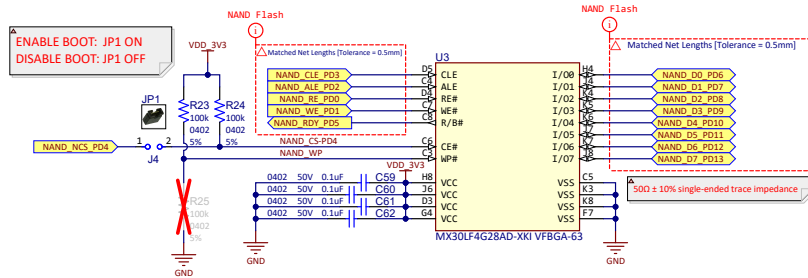
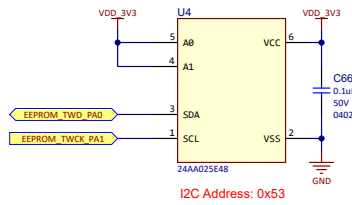

Figure 7-5. NAND Flash, SDMMCs and EEPROM Schematic

4Gb NAND Flash



EEPROM



μSD-CARD socket

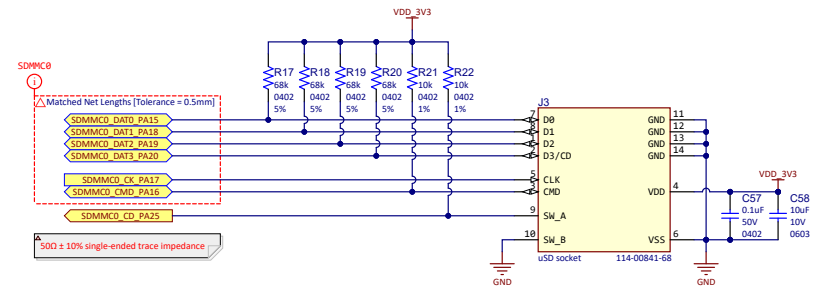

SD Card / Radio module socket

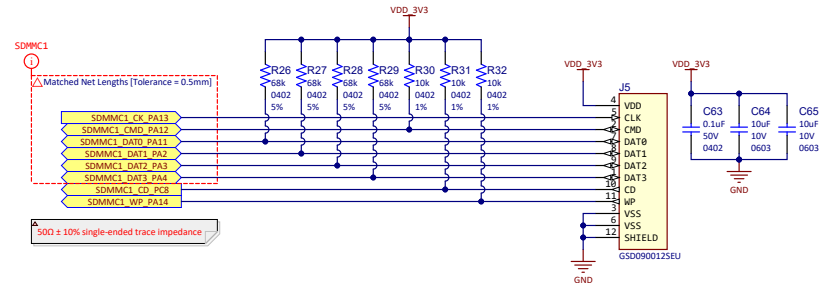

Figure 7-6. Ethernet Schematic

ETH0

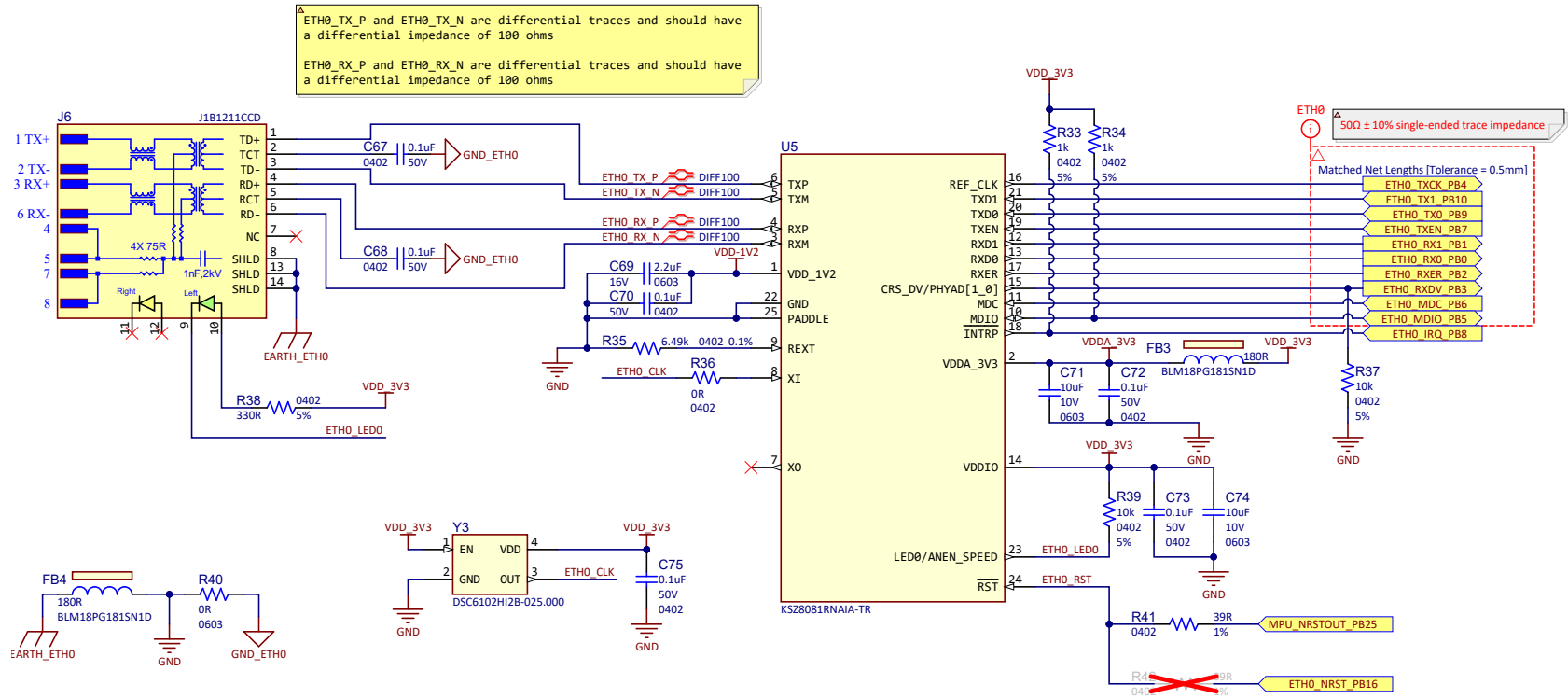

Figure 7-7. CAN Schematic

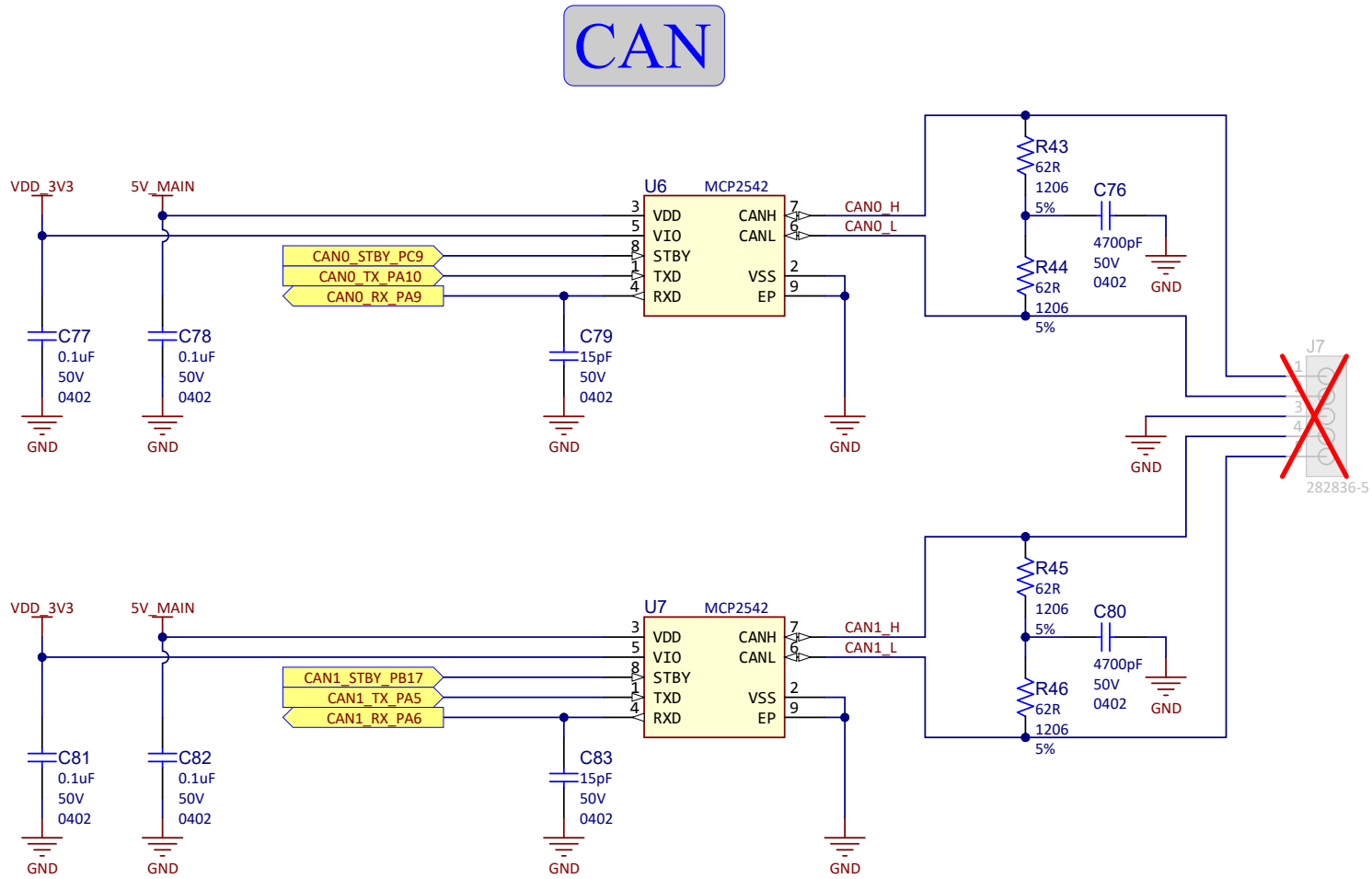

Figure 7-8. User Interface Schematic

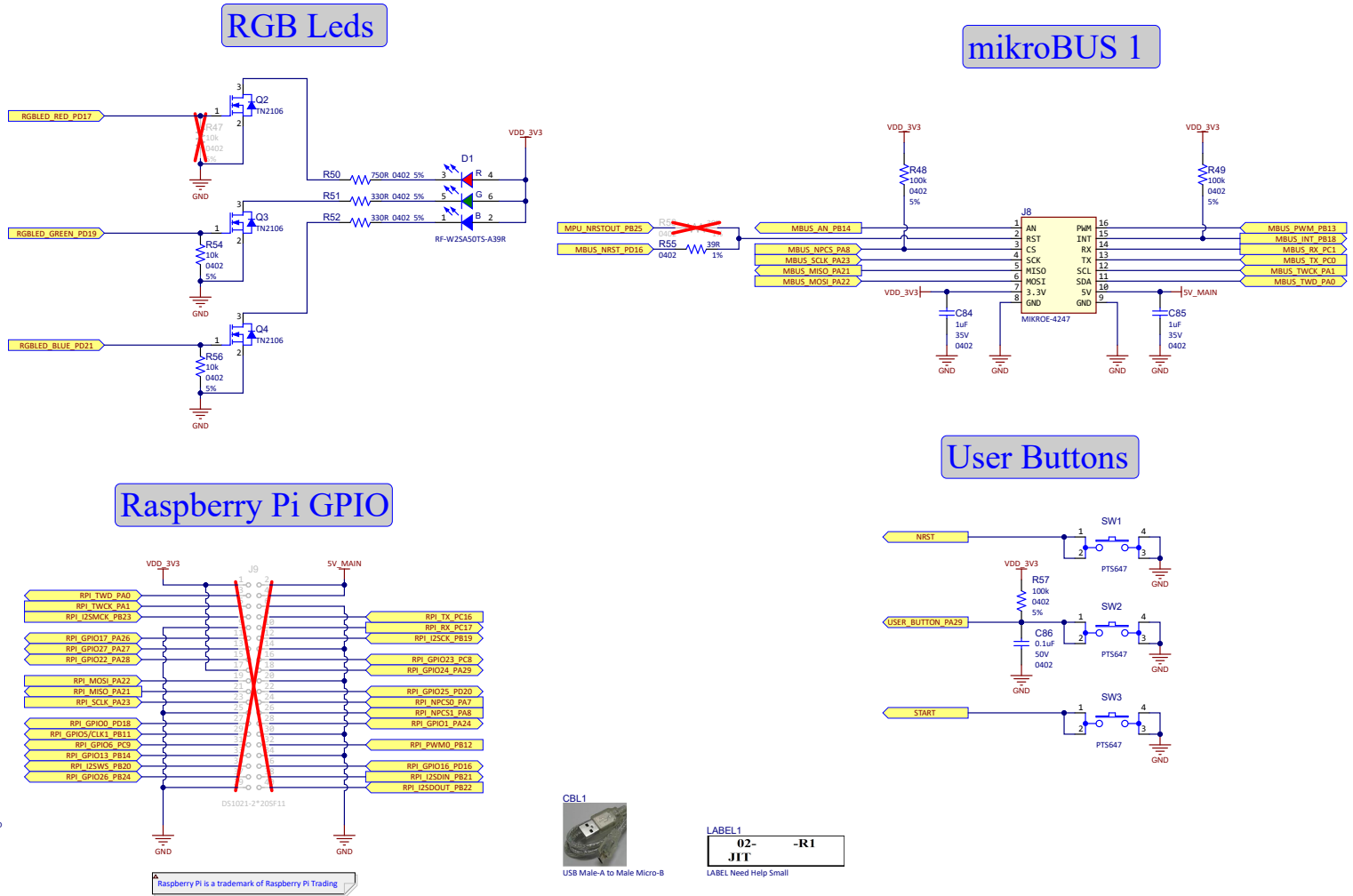

Figure 7-9. USB Host Schematic

USB Host Interface

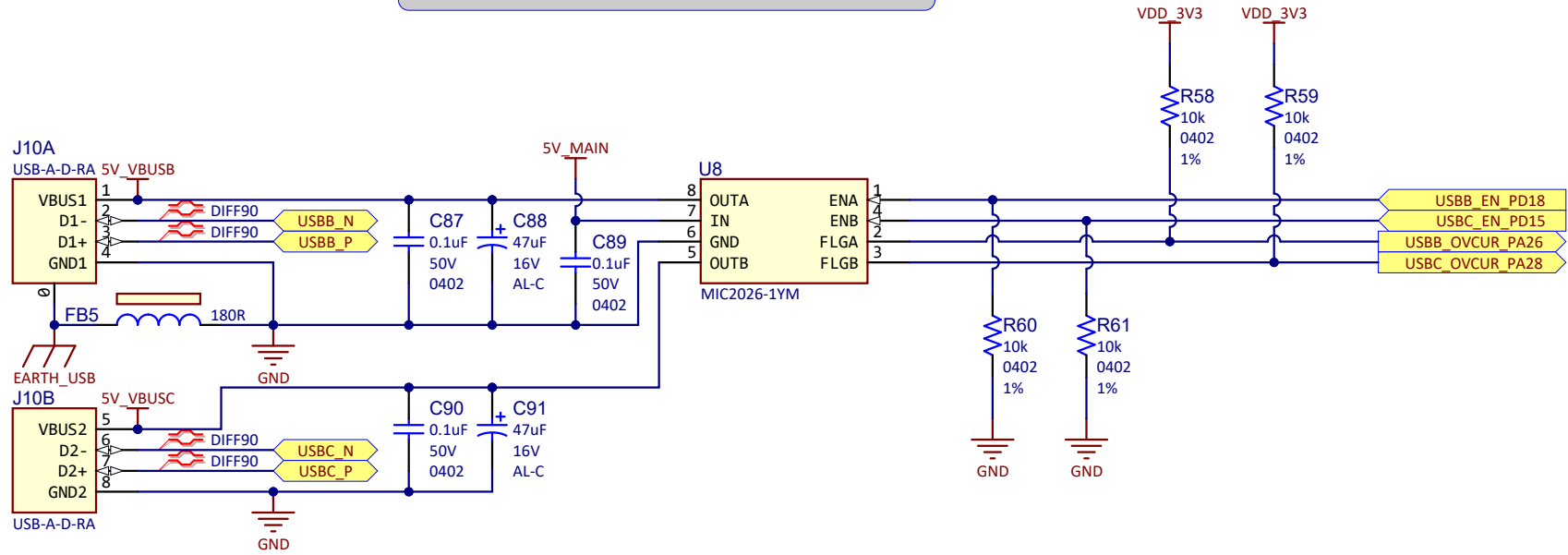
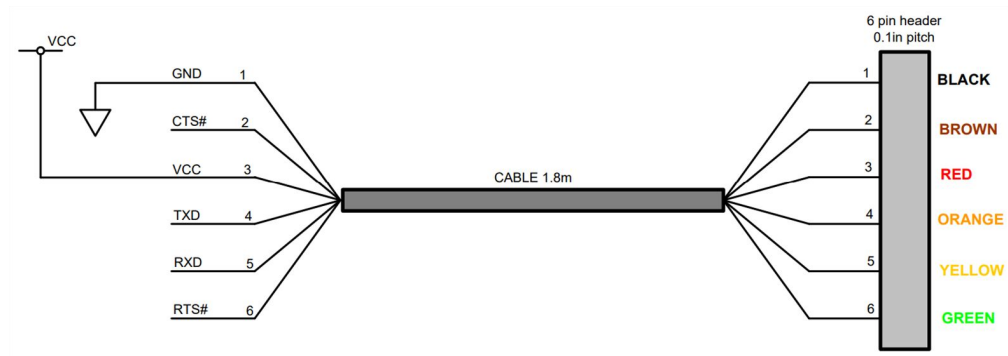
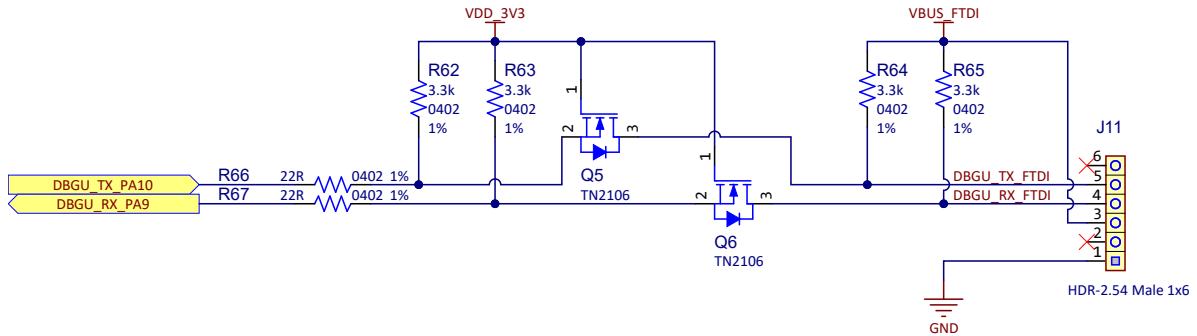

Figure 7-10. Debug Interface and JTAG with SAM-ICE Schematic

Debug Interface



JTAG with SAM-ICE

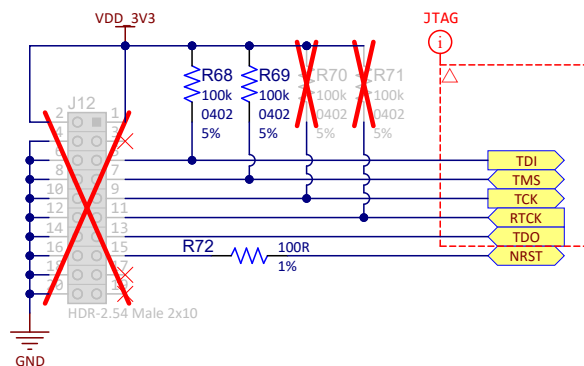

Figure 7-11. LCD RGB666 Interface Schematic

LCD RGB666 Interface

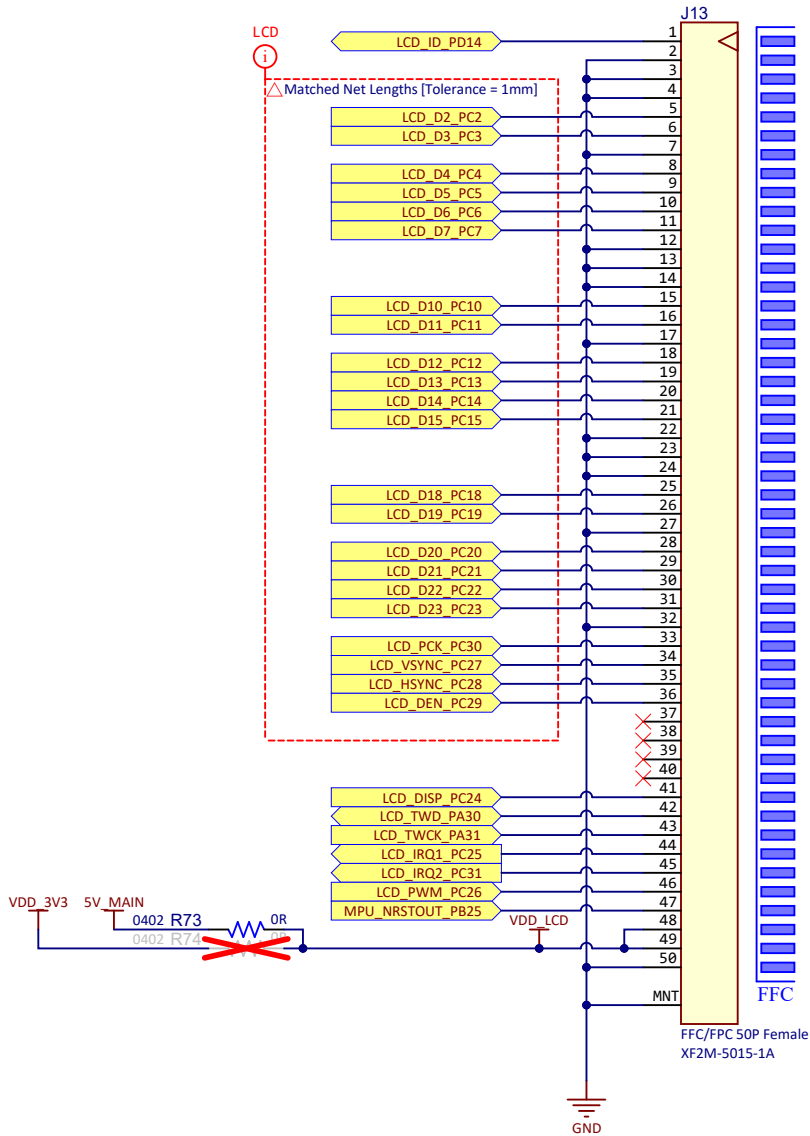
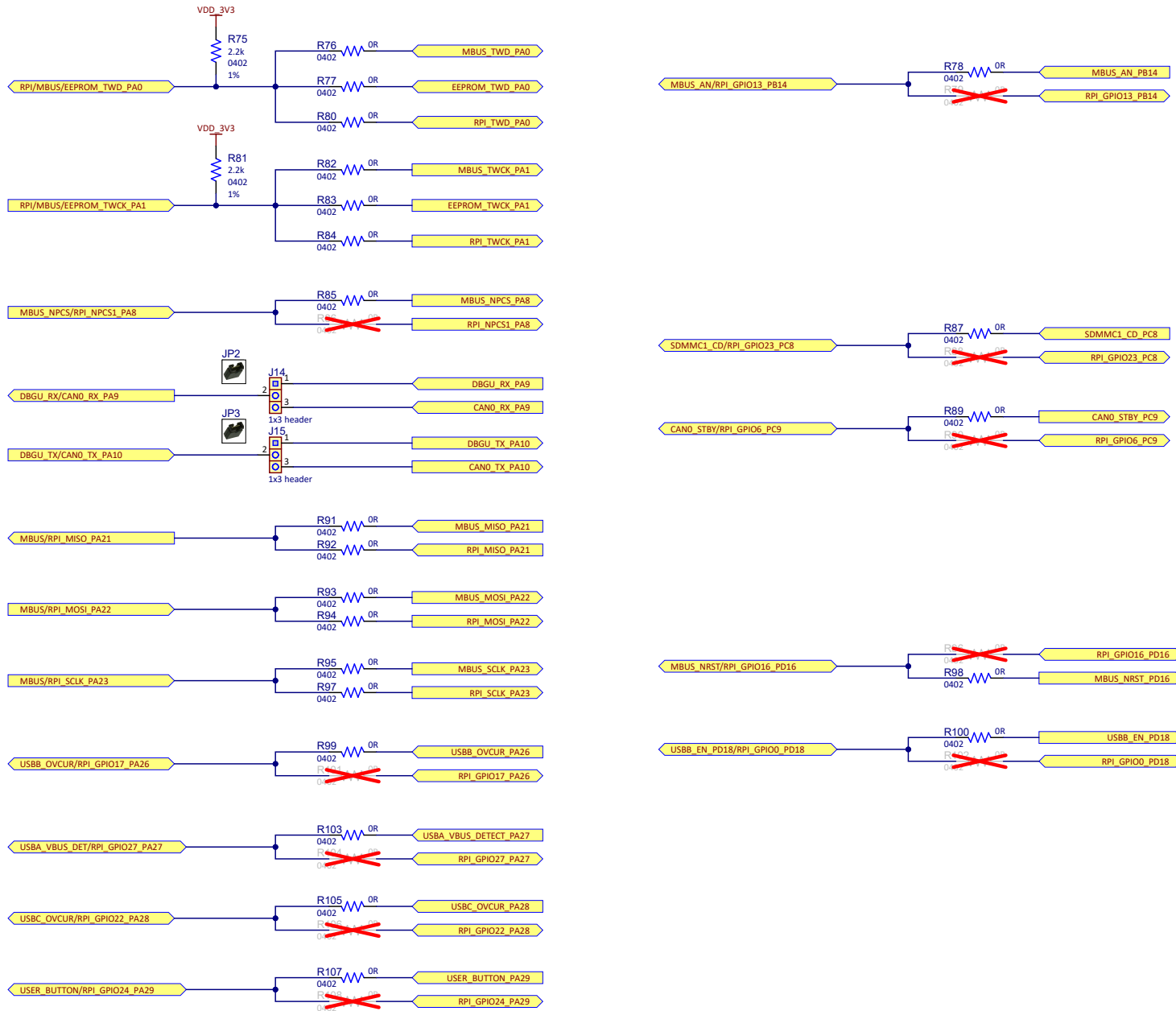

Figure 7-12. PIO Muxing Schematic



7.2 SAM9X60-Curiosity Layout

This section contains the layout graphics for the SAM9X60-Curiosity board:

- Layer 1: Top Layer, [Figure 7-13](#)
- Layer 2: Mid Layer 1, [Figure 7-14](#)
- Layer 3: Mid Layer 2, [Figure 7-15](#)
- Layer 4: Bottom Layer, [Figure 7-16](#)
- Top Components Placement, [Figure 7-17](#)
- Bottom Components Placement, [Figure 7-18](#)

Figure 7-13. SAM9X60-Curiosity Layout: Top Layer

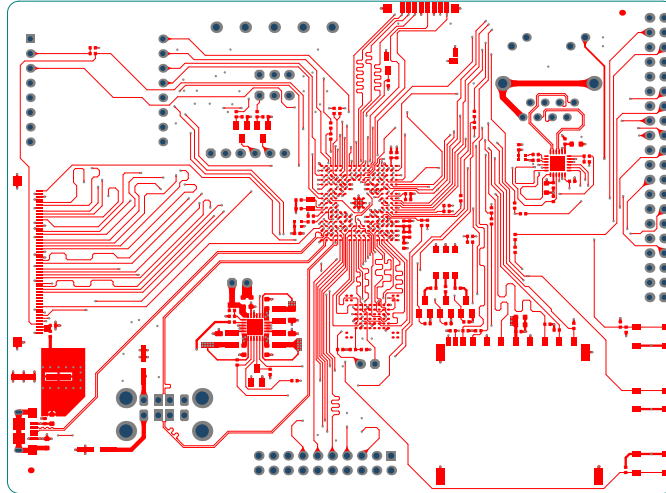

Figure 7-14. SAM9X60-Curiosity Layout: Mid Layer 1 (Ground)

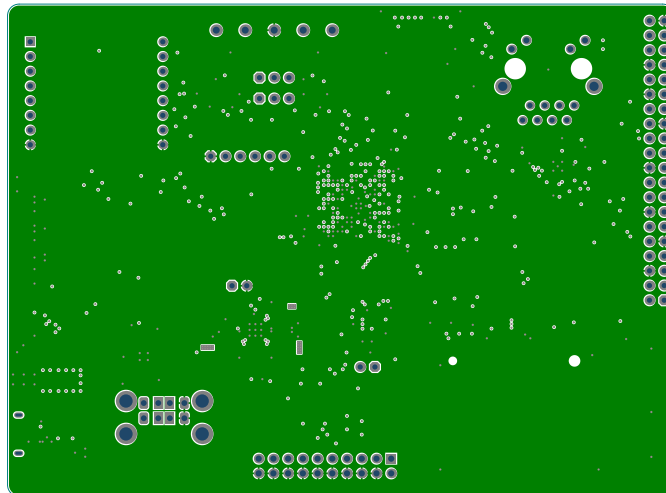

Figure 7-15. SAM9X60-Curiosity Layout: Mid Layer 2 (Power Supplies)

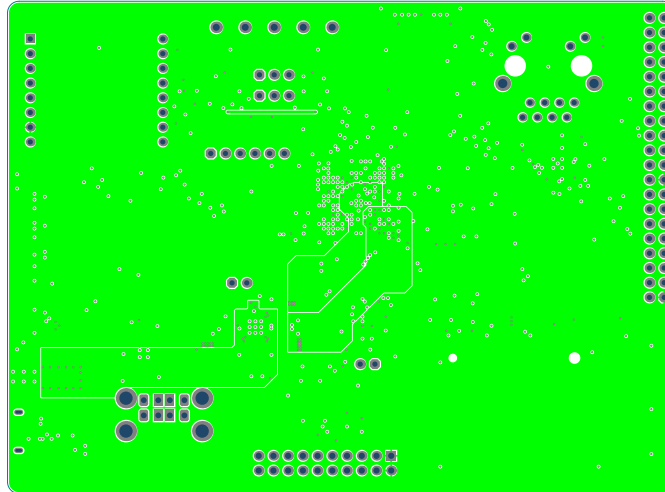

Figure 7-16. SAM9X60-Curiosity Layout: Bottom Layer

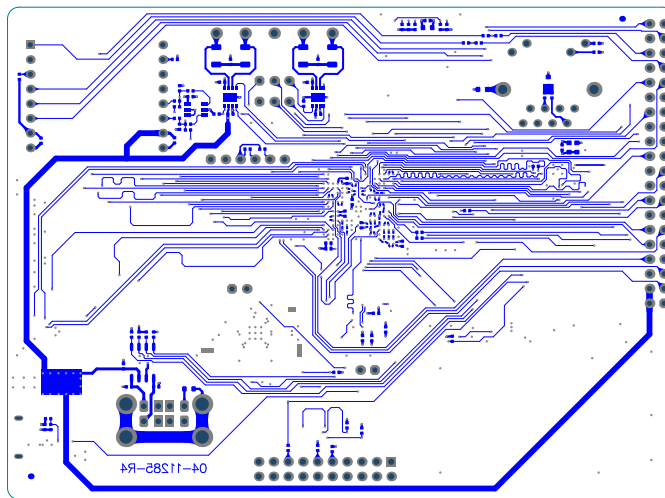

Figure 7-17. SAM9X60-Curiosity Layout: Top Silkscreen

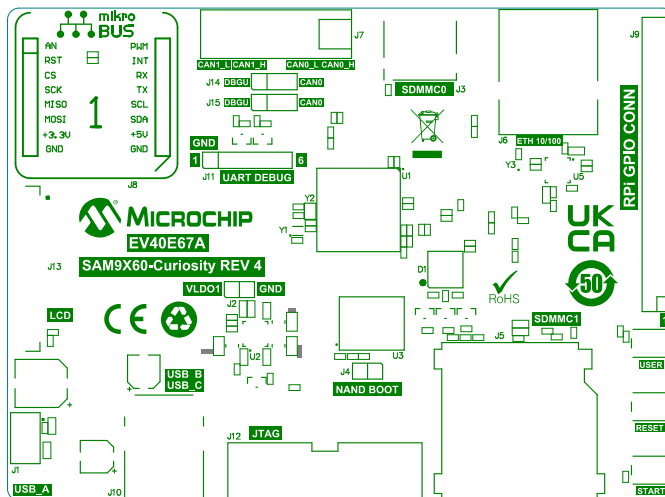
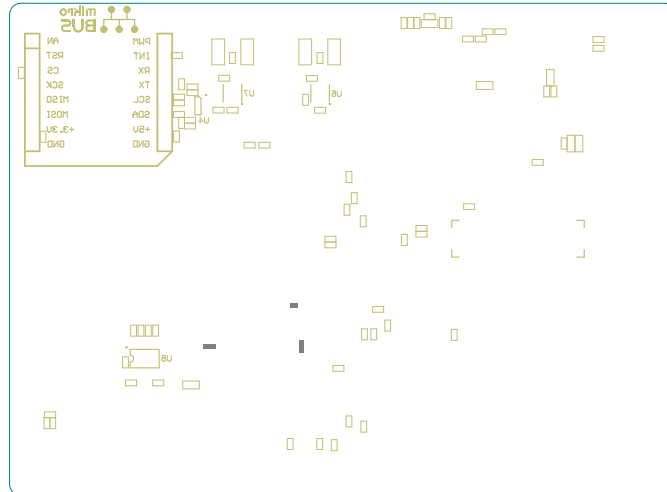

Figure 7-18. SAM9X60-Curiosity Layout: Bottom Silkscreen

8. Revision History

8.1 Rev C - 09/2023

Updated [DDR2/SDRAM](#).
Updated table title in [GPIO Interface](#).

8.2 Rev B - 04/2023

Added [Errata](#).
Added [Ordering Information](#).

8.3 Rev A - 07/2022

Initial release.

Microchip Information

The Microchip Website

Microchip provides online support via our website at www.microchip.com/. This website is used to make files and information easily available to customers. Some of the content available includes:

- **Product Support** – Data sheets and errata, application notes and sample programs, design resources, user’s guides and hardware support documents, latest software releases and archived software
- **General Technical Support** – Frequently Asked Questions (FAQs), technical support requests, online discussion groups, Microchip design partner program member listing
- **Business of Microchip** – Product selector and ordering guides, latest Microchip press releases, listing of seminars and events, listings of Microchip sales offices, distributors and factory representatives

Product Change Notification Service

Microchip’s product change notification service helps keep customers current on Microchip products. Subscribers will receive email notification whenever there are changes, updates, revisions or errata related to a specified product family or development tool of interest.

To register, go to www.microchip.com/pcn and follow the registration instructions.

Customer Support

Users of Microchip products can receive assistance through several channels:

- Distributor or Representative
- Local Sales Office
- Embedded Solutions Engineer (ESE)
- Technical Support

Customers should contact their distributor, representative or ESE for support. Local sales offices are also available to help customers. A listing of sales offices and locations is included in this document.

Technical support is available through the website at: www.microchip.com/support

Microchip Devices Code Protection Feature

Note the following details of the code protection feature on Microchip products:

- Microchip products meet the specifications contained in their particular Microchip Data Sheet.
- Microchip believes that its family of products is secure when used in the intended manner, within operating specifications, and under normal conditions.
- Microchip values and aggressively protects its intellectual property rights. Attempts to breach the code protection features of Microchip product is strictly prohibited and may violate the Digital Millennium Copyright Act.
- Neither Microchip nor any other semiconductor manufacturer can guarantee the security of its code. Code protection does not mean that we are guaranteeing the product is “unbreakable”. Code protection is constantly evolving. Microchip is committed to continuously improving the code protection features of our products.

Legal Notice

This publication and the information herein may be used only with Microchip products, including to design, test, and integrate Microchip products with your application. Use of this information in any other manner violates these terms. Information regarding device applications is provided only for your convenience and may be superseded by updates. It is your responsibility to ensure

that your application meets with your specifications. Contact your local Microchip sales office for additional support or, obtain additional support at www.microchip.com/en-us/support/design-help/client-support-services.

THIS INFORMATION IS PROVIDED BY MICROCHIP "AS IS". MICROCHIP MAKES NO REPRESENTATIONS OR WARRANTIES OF ANY KIND WHETHER EXPRESS OR IMPLIED, WRITTEN OR ORAL, STATUTORY OR OTHERWISE, RELATED TO THE INFORMATION INCLUDING BUT NOT LIMITED TO ANY IMPLIED WARRANTIES OF NON-INFRINGEMENT, MERCHANTABILITY, AND FITNESS FOR A PARTICULAR PURPOSE, OR WARRANTIES RELATED TO ITS CONDITION, QUALITY, OR PERFORMANCE.

IN NO EVENT WILL MICROCHIP BE LIABLE FOR ANY INDIRECT, SPECIAL, PUNITIVE, INCIDENTAL, OR CONSEQUENTIAL LOSS, DAMAGE, COST, OR EXPENSE OF ANY KIND WHATSOEVER RELATED TO THE INFORMATION OR ITS USE, HOWEVER CAUSED, EVEN IF MICROCHIP HAS BEEN ADVISED OF THE POSSIBILITY OR THE DAMAGES ARE FORESEEABLE. TO THE FULLEST EXTENT ALLOWED BY LAW, MICROCHIP'S TOTAL LIABILITY ON ALL CLAIMS IN ANY WAY RELATED TO THE INFORMATION OR ITS USE WILL NOT EXCEED THE AMOUNT OF FEES, IF ANY, THAT YOU HAVE PAID DIRECTLY TO MICROCHIP FOR THE INFORMATION.

Use of Microchip devices in life support and/or safety applications is entirely at the buyer's risk, and the buyer agrees to defend, indemnify and hold harmless Microchip from any and all damages, claims, suits, or expenses resulting from such use. No licenses are conveyed, implicitly or otherwise, under any Microchip intellectual property rights unless otherwise stated.

Trademarks

The Microchip name and logo, the Microchip logo, Adaptec, AVR, AVR logo, AVR Freaks, BesTime, BitCloud, CryptoMemory, CryptoRF, dsPIC, flexPWR, HELDO, IGLOO, JukeBlox, KeeLoq, Klear, LANCheck, LinkMD, maXStylus, maXTouch, MediaLB, megaAVR, Microsemi, Microsemi logo, MOST, MOST logo, MPLAB, OptoLyzer, PIC, picoPower, PICSTART, PIC32 logo, PolarFire, Prochip Designer, QTouch, SAM-BA, SenGenuity, SpyNIC, SST, SST Logo, SuperFlash, Symmetricom, SyncServer, Tachyon, TimeSource, tinyAVR, UNI/O, Vectron, and XMEGA are registered trademarks of Microchip Technology Incorporated in the U.S.A. and other countries.

AgileSwitch, APT, ClockWorks, The Embedded Control Solutions Company, EtherSynch, Flashtec, Hyper Speed Control, HyperLight Load, Libero, motorBench, mTouch, Powermite 3, Precision Edge, ProASIC, ProASIC Plus, ProASIC Plus logo, Quiet-Wire, SmartFusion, SyncWorld, Temux, TimeCesium, TimeHub, TimePictra, TimeProvider, TrueTime, and ZL are registered trademarks of Microchip Technology Incorporated in the U.S.A.

Adjacent Key Suppression, AKS, Analog-for-the-Digital Age, Any Capacitor, AnyIn, AnyOut, Augmented Switching, BlueSky, BodyCom, Clockstudio, CodeGuard, CryptoAuthentication, CryptoAutomotive, CryptoCompanion, CryptoController, dsPICDEM, dsPICDEM.net, Dynamic Average Matching, DAM, ECAN, Espresso T1S, EtherGREEN, GridTime, IdealBridge, In-Circuit Serial Programming, ICSP, INICnet, Intelligent Paralleling, IntelliMOS, Inter-Chip Connectivity, JitterBlocker, Knob-on-Display, KoD, maxCrypto, maxView, memBrain, Mindi, MiWi, MPASM, MPF, MPLAB Certified logo, MPLIB, MPLINK, MultiTRAK, NetDetach, Omniscient Code Generation, PICDEM, PICDEM.net, PICkit, PICtail, PowerSmart, PureSilicon, QMatrix, REAL ICE, Ripple Blocker, RTAX, RTG4, SAM-ICE, Serial Quad I/O, simpleMAP, SimpliPHY, SmartBuffer, SmartHLS, SMART-I.S., storClad, SQL, SuperSwitcher, SuperSwitcher II, Switchtec, SynchroPHY, Total Endurance, Trusted Time, TSHARC, USBCheck, VariSense, VectorBlox, VeriPHY, ViewSpan, WiperLock, XpressConnect, and ZENA are trademarks of Microchip Technology Incorporated in the U.S.A. and other countries.

SQTP is a service mark of Microchip Technology Incorporated in the U.S.A.

The Adaptec logo, Frequency on Demand, Silicon Storage Technology, and Symmcom are registered trademarks of Microchip Technology Inc. in other countries.

GestIC is a registered trademark of Microchip Technology Germany II GmbH & Co. KG, a subsidiary of Microchip Technology Inc., in other countries.

All other trademarks mentioned herein are property of their respective companies.

© 2023, Microchip Technology Incorporated and its subsidiaries. All Rights Reserved.

ISBN: 978-1-6683-2999-3

AMBA, Arm, Arm7, Arm7TDMI, Arm9, Arm11, Artisan, big.LITTLE, Cordio, CoreLink, CoreSight, Cortex, DesignStart, DynamIQ, Jazelle, Keil, Mali, Mbed, Mbed Enabled, NEON, POP, RealView, SecurCore, Socrates, Thumb, TrustZone, ULINK, ULINK2, ULINK-ME, ULINK-PLUS, ULINKpro, μ Vision, Versatile are trademarks or registered trademarks of Arm Limited (or its subsidiaries) in the US and/or elsewhere.

Quality Management System

For information regarding Microchip's Quality Management Systems, please visit www.microchip.com/quality.

Worldwide Sales and Service

AMERICAS	ASIA/PACIFIC	ASIA/PACIFIC	EUROPE
<p>Corporate Office 2355 West Chandler Blvd. Chandler, AZ 85224-6199 Tel: 480-792-7200 Fax: 480-792-7277 Technical Support: www.microchip.com/support Web Address: www.microchip.com</p> <p>Atlanta Duluth, GA Tel: 678-957-9614 Fax: 678-957-1455</p> <p>Austin, TX Tel: 512-257-3370</p> <p>Boston Westborough, MA Tel: 774-760-0087 Fax: 774-760-0088</p> <p>Chicago Itasca, IL Tel: 630-285-0071 Fax: 630-285-0075</p> <p>Dallas Addison, TX Tel: 972-818-7423 Fax: 972-818-2924</p> <p>Detroit Novi, MI Tel: 248-848-4000</p> <p>Houston, TX Tel: 281-894-5983</p> <p>Indianapolis Noblesville, IN Tel: 317-773-8323 Fax: 317-773-5453 Tel: 317-536-2380</p> <p>Los Angeles Mission Viejo, CA Tel: 949-462-9523 Fax: 949-462-9608 Tel: 951-273-7800</p> <p>Raleigh, NC Tel: 919-844-7510</p> <p>New York, NY Tel: 631-435-6000</p> <p>San Jose, CA Tel: 408-735-9110 Tel: 408-436-4270</p> <p>Canada - Toronto Tel: 905-695-1980 Fax: 905-695-2078</p>	<p>Australia - Sydney Tel: 61-2-9868-6733</p> <p>China - Beijing Tel: 86-10-8569-7000</p> <p>China - Chengdu Tel: 86-28-8665-5511</p> <p>China - Chongqing Tel: 86-23-8980-9588</p> <p>China - Dongguan Tel: 86-769-8702-9880</p> <p>China - Guangzhou Tel: 86-20-8755-8029</p> <p>China - Hangzhou Tel: 86-571-8792-8115</p> <p>China - Hong Kong SAR Tel: 852-2943-5100</p> <p>China - Nanjing Tel: 86-25-8473-2460</p> <p>China - Qingdao Tel: 86-532-8502-7355</p> <p>China - Shanghai Tel: 86-21-3326-8000</p> <p>China - Shenyang Tel: 86-24-2334-2829</p> <p>China - Shenzhen Tel: 86-755-8864-2200</p> <p>China - Suzhou Tel: 86-186-6233-1526</p> <p>China - Wuhan Tel: 86-27-5980-5300</p> <p>China - Xian Tel: 86-29-8833-7252</p> <p>China - Xiamen Tel: 86-592-2388138</p> <p>China - Zhuhai Tel: 86-756-3210040</p>	<p>India - Bangalore Tel: 91-80-3090-4444</p> <p>India - New Delhi Tel: 91-11-4160-8631</p> <p>India - Pune Tel: 91-20-4121-0141</p> <p>Japan - Osaka Tel: 81-6-6152-7160</p> <p>Japan - Tokyo Tel: 81-3-6880-3770</p> <p>Korea - Daegu Tel: 82-53-744-4301</p> <p>Korea - Seoul Tel: 82-2-554-7200</p> <p>Malaysia - Kuala Lumpur Tel: 60-3-7651-7906</p> <p>Malaysia - Penang Tel: 60-4-227-8870</p> <p>Philippines - Manila Tel: 63-2-634-9065</p> <p>Singapore Tel: 65-6334-8870</p> <p>Taiwan - Hsin Chu Tel: 886-3-577-8366</p> <p>Taiwan - Kaohsiung Tel: 886-7-213-7830</p> <p>Taiwan - Taipei Tel: 886-2-2508-8600</p> <p>Thailand - Bangkok Tel: 66-2-694-1351</p> <p>Vietnam - Ho Chi Minh Tel: 84-28-5448-2100</p>	<p>Austria - Wels Tel: 43-7242-2244-39 Fax: 43-7242-2244-393</p> <p>Denmark - Copenhagen Tel: 45-4485-5910 Fax: 45-4485-2829</p> <p>Finland - Espoo Tel: 358-9-4520-820</p> <p>France - Paris Tel: 33-1-69-53-63-20 Fax: 33-1-69-30-90-79</p> <p>Germany - Garching Tel: 49-8931-9700</p> <p>Germany - Haan Tel: 49-2129-3766400</p> <p>Germany - Heilbronn Tel: 49-7131-72400</p> <p>Germany - Karlsruhe Tel: 49-721-625370</p> <p>Germany - Munich Tel: 49-89-627-144-0 Fax: 49-89-627-144-44</p> <p>Germany - Rosenheim Tel: 49-8031-354-560</p> <p>Israel - Ra'anana Tel: 972-9-744-7705</p> <p>Italy - Milan Tel: 39-0331-742611 Fax: 39-0331-466781</p> <p>Italy - Padova Tel: 39-049-7625286</p> <p>Netherlands - Drunen Tel: 31-416-690399 Fax: 31-416-690340</p> <p>Norway - Trondheim Tel: 47-72884388</p> <p>Poland - Warsaw Tel: 48-22-3325737</p> <p>Romania - Bucharest Tel: 40-21-407-87-50</p> <p>Spain - Madrid Tel: 34-91-708-08-90 Fax: 34-91-708-08-91</p> <p>Sweden - Gothenberg Tel: 46-31-704-60-40</p> <p>Sweden - Stockholm Tel: 46-8-5090-4654</p> <p>UK - Wokingham Tel: 44-118-921-5800 Fax: 44-118-921-5820</p>