

---

---

**BM83 Bluetooth® Audio Development Board User's Guide**

---

---

---

## Introduction

---

The BM83 Bluetooth Audio Development Board (BM83 EVB) enables the user to evaluate and demonstrate the functionality of the BM83 audio module and IS2083BM System-on-Chip (SoC). This board is a complete, all-in-one solution to develop multiple Bluetooth audio applications including portable speakers and headphones. The BM83 EVB features an on-board PIC32 for Host MCU mode applications, an external codec to improve audio quality, a digital microphone to capture voice audio, indicator LEDs and buttons for ease of development.

In addition to the BM83 EVB, the IS2083 SDK and IS208x\_Config\_GUI\_Tool (Config Tool) are provided to customize the audio processing settings.

---

## Features

---

- BM83 module, qualified for Bluetooth 5.0 specifications
- On-board microcontroller (PIC32MX450F256L) for easy operation and feature demonstration
- Plug-in module (PIM) socket for external microcontroller (MCU)
- STMicroelectronics codec (STA369BW) Daughter Board
- Digital Microphone (Knowles' SPH0641LU4H-1) Daughter Board
- J-Link 6-Pin Adapter Board for IS2083BM debugging
- On-board keypad matrix (audio control buttons) that can be controlled either by the BM83 module or the on-board PIC32 MCU, which makes it easy for playback control
- Aux-in, MIC-in and Stereo out ports
- On-board thermistor
- 2 LEDs for the Bluetooth subsystem and various other LEDs configurable by the on-board MCU
- JTAG program/debug port, USB to UART port, XPRO header interfaces
- Li-ion battery connector, 15V DC power jack and USB power source

---

## Table of Contents

---

Introduction.....	1
Features.....	1
1. Quick References.....	4
1.1. Reference Documentation.....	4
1.2. Hardware Requirements.....	4
1.3. Software Requirements.....	4
1.4. Acronyms/Abbreviations.....	4
2. Kit Overview.....	8
2.1. Kit Contents.....	8
3. Hardware.....	10
3.1. Hardware Features.....	11
4. Embedded Mode Quick Demo.....	18
5. Firmware Update.....	20
5.1. Firmware Update over UART.....	20
5.2. Firmware Update over USB .....	23
6. Customizing Module Parameters.....	28
6.1. Config Tool Setup.....	28
7. Appendix A: BM83 EVB Reference Schematics.....	41
8. Appendix B: STA369BW Audio Daughter Board.....	55
9. Appendix C: Digital Microphone Daughter Board.....	57
10. Appendix D: J-Link 6-Pin Adapter Board.....	58
11. Appendix E: Updating PIC32 MCU Parameters.....	59
12. Appendix F: Hardware Setup for Application Demo in Host MCU Mode.....	63
12.1. Host MCU Mode Quick Demo.....	64
13. Appendix G: Hardware Setup for Application Demo in Embedded Mode.....	67
14. Appendix H: Bluetooth Audio Demonstration in Embedded Mode with Internal Codec.....	69
15. Regulatory Approvals.....	70
15.1. United States.....	70
15.2. Canada.....	71
15.3. Europe.....	71
16. Document Revision History.....	72
The Microchip Website.....	73
Product Change Notification Service.....	73

Customer Support.....	73
Microchip Devices Code Protection Feature.....	73
Legal Notice.....	73
Trademarks.....	74
Quality Management System.....	74
Worldwide Sales and Service.....	75

## 1. Quick References

### 1.1 Reference Documentation

For further information, refer to the following:

- *BM83 Bluetooth® Stereo Audio Module Data Sheet*
- *IS2083 Bluetooth® Stereo Audio SoC Data Sheet*
- *IS2083 SDK User's Guide (DS50002894)*
- *BM83 Host MCU Firmware Development Guide*
- *IS2083 Bluetooth® Audio Application Design Guide*
- *IS2083 SDK Debugger User's Guide*
- *IS2083 Reference Design Application Note*

**Note:** For a complete list of development support tools and documentation, visit [www.microchip.com/BM83](http://www.microchip.com/BM83).

### 1.2 Hardware Requirements

- BM83 Bluetooth® Audio Development Board (BM83 EVB)
- BM83 module mounted on BM83 Carrier Board
- Bluetooth-enabled smartphone:
  - Android™ device running on Android 4.3 or later version
  - iOS: iPhone® 4S or later version
- Windows® host PC with USB port
- Speaker, microphone or headset
- Type-A to Micro-B USB cable
- STA369BW Audio Daughter Board
- Digital Microphone Daughter Board
- 15V DC power adapter
- MPLAB® REAL ICE™/MPLAB ICD 3/PICKit™ 3
- J-Link 6-Pin Adapter Board

### 1.3 Software Requirements

**Note:** For the following software tools and firmware files, refer to [www.microchip.com/BM83](http://www.microchip.com/BM83).

- IS2083 firmware
- Host MCU firmware
- isUpdate tool
- Config GUI tool
- MPLAB Integrated Development Environment (MPLAB X IDE) tool
- Microchip Bluetooth Audio Application for smartphone

**Note:** MPLAB X IDE is available for download from Microchip website at: [www.microchip.com/mplab/mplab-x-ide](http://www.microchip.com/mplab/mplab-x-ide).

### 1.4 Acronyms/Abbreviations

**Table 1-1. Acronyms/Abbreviations**

Acronyms/Abbreviations	Description
A2DP	Advanced Audio Distribution Profile

.....continued

Acronyms/Abbreviations	Description
AAC	Advanced Audio Codec
ADC	Analog-to-Digital Converter
AEC	Acoustic Echo Cancellation
AFH	Adaptive Frequency Hopping
ANCS	Apple Notification Center Service
API	Application Programming Interfaces
AVRCP	Audio/Video Remote Control Profile
AW	Audio Widening
BDR	Basic Data Rate
BER	Bit Error Rate
BLE	Bluetooth Low Energy
BOM	Bill of Materials
BPF	Band Pass Filter
BR	Basic Rate
CVSD	Continuous Variable Slope Delta
DAC	Digital-to-Analog Converter
DFU	Device Firmware Upgrade
DIS	Device Information Service
DLE	Data Length Extension
DPSK	Differential Phase Shift Keying
DQPSK	Differential Quadrature Phase Shift Keying
DR	Receive Data
DSP	Digital Signal Processor
DT	Transmit Data
EDR	Enhanced Data Rate
EMC	Electromagnetic Compatibility
EVB	Evaluation Board
FET	Field Effect Transistor
GAP	General Access Profile
GATT	General Attribute Profile
GFSK	Gaussian Frequency Shift Keying
GPIO	General Purpose Input Output
GUI	Graphical User Interface
HFP	Hands-free Profile
HPF	High Pass Filter
HSP	Headset Profile
HW	Hardware
I2C/I <sup>2</sup> C	Inter-Integrated Circuit
I2S/I <sup>2</sup> S	Inter-IC Sound
IC	Integrated Circuit

.....continued

Acronyms/Abbreviations	Description
ICSP	In-Circuit Serial Programming
IDE	Integrated Development Environment
IF	Intermediate Frequency
IPE	Integrated Programming Environment
JTAG	Joint Test Action Group
LDO	Low-Dropout
LED	Light Emitting Diode
LNA	Low-Noise Amplifier
LPA	Linear Power Amplifier
LSB	Least Significant Bit
MAC	Medium Access Control
MB DRC	Multiband Dynamic Range Compression
MCLK	Master Clock
MCU	Microcontroller
MEMS	Micro-Electro-Mechanical Systems
MFB	Multi-function Button
Modem	Modulator-demodulator
MPA	Medium Power Amplifier
mSBC	Modified Sub-band Coding
MSPK	Multi-speaker
NR	Noise Reduction
OTA	Over-the-Air
PBAP	Phone Book Access Profile
PCB	Printed Circuit Board
PCM	Pulse Code Modulation
PDM	Pulse Density Modulation
PIM	Plug-in Module
PLC	Packet Loss Concealment
PMU	Power Management Unit
POR	Power-on Reset
PWM	Pulse Width Modulation
RF	Radio Frequency
RFS	Receive Frame Sync
RoHS	Restriction of Hazardous Substances
RSSI	Received Signal Strength Indicator
RX	Receiver
SAR	Successive Approximation Register
SBC	Sub-band Coding
SCO	Synchronous Connection-Oriented
SDK	Software Development Kit

.....continued

Acronyms/Abbreviations	Description
SIG	Special Interest Group
SNR	Signal-to-Noise Ratio
SoC	System-on-Chip
SPP	Serial Port Profile
SW	Software
TX	Transmitter
UART	Universal Asynchronous Receiver-Transmitter
UI	User Interface
USB	Universal Serial Bus
VB	Virtual Bass Enhancement
VCO	Voltage-controlled Oscillator
WDT	Watchdog Timer

## 2. Kit Overview

This section provides an overview of the BM83 EVB. The following figure illustrates the top view of the BM83 EVB with its components.

**Figure 2-1. BM83 EVB Components**

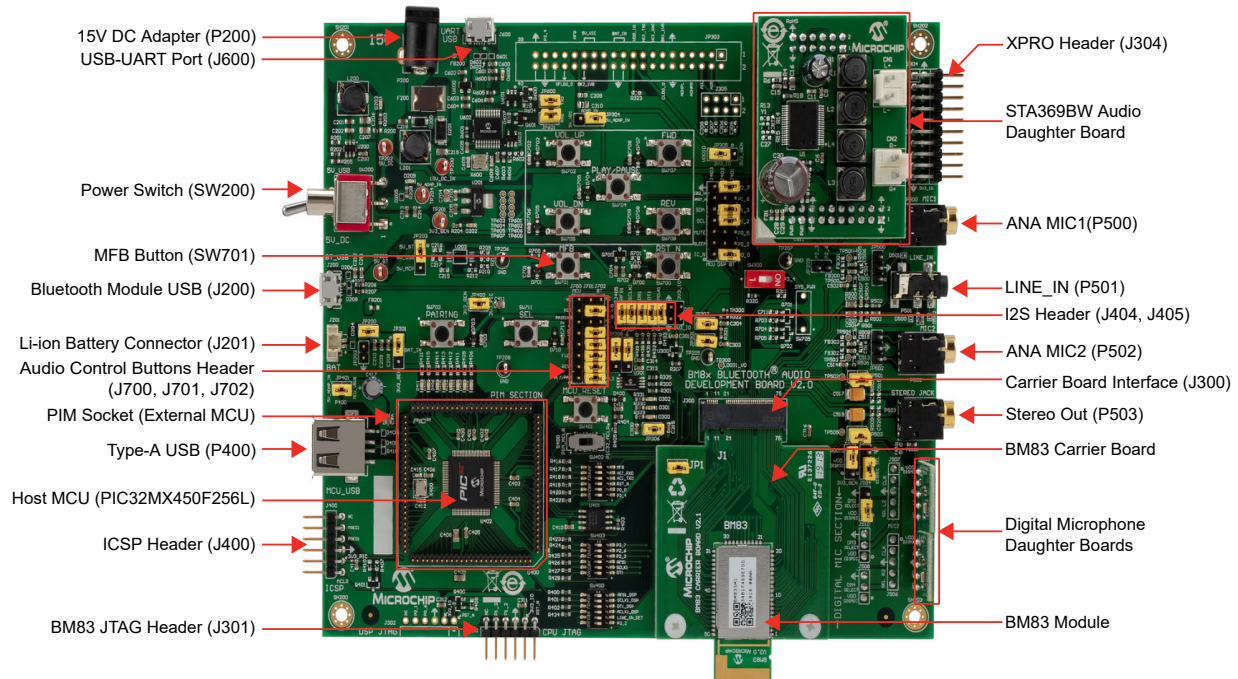

### 2.1 Kit Contents

The BM83 EVB includes the following:

- One BM83 EVB that contains a BM83 module (BM83SM1-00AA) mounted on a BM83 Carrier Board
- One 15V DC power adapter
- One pair of speaker cables
- One Type-A to Micro-B USB cable
- One STA369BW Audio Daughter Board
- Two Digital Microphone Daughter Boards
- One J-link 6-pin Adapter Board



Figure 2-2. Kit Contents

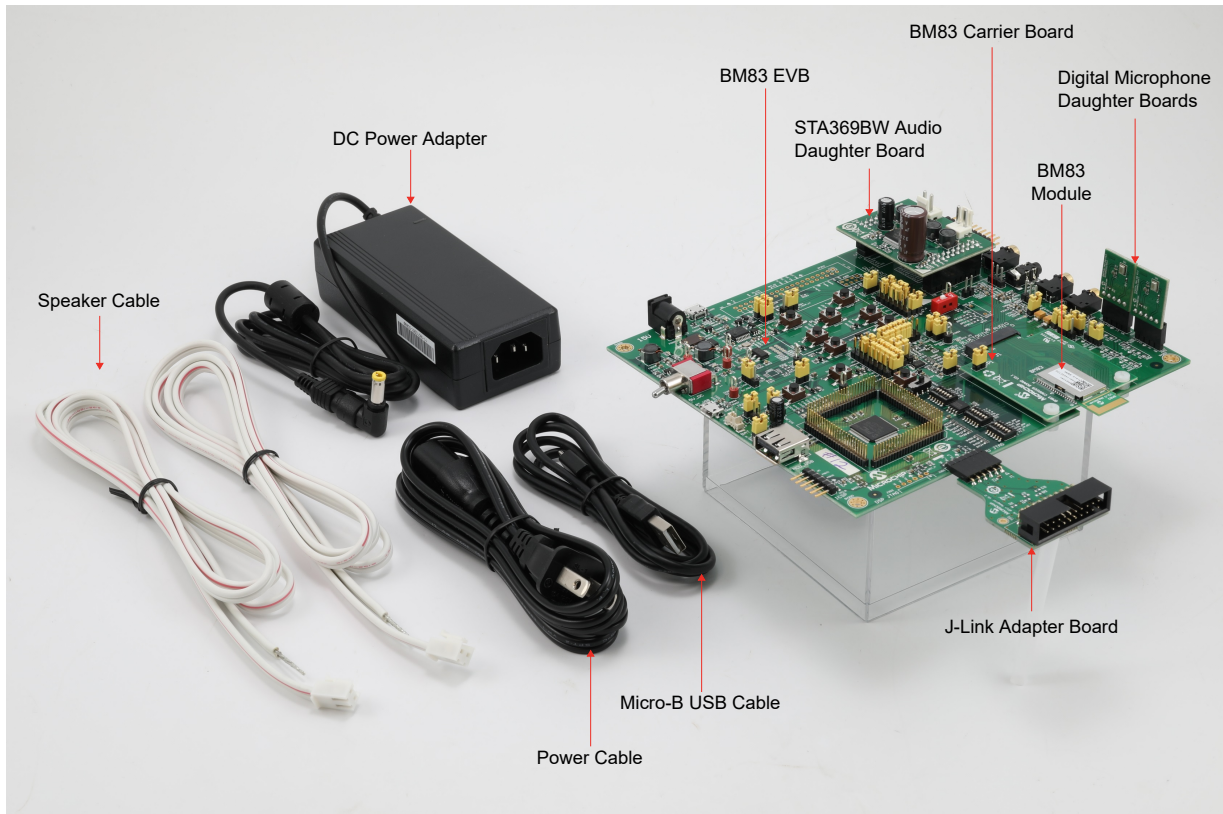

**Note:** If any part of the BM83 EVB is missing, contact your Microchip sales office for assistance. A list of Microchip offices for sales and service is provided on the back page of this document.

### 3. Hardware

This chapter describes the hardware features of the BM83 EVB. The BM83 EVB includes a range of peripheral components.

**Figure 3-1. Block Diagram**

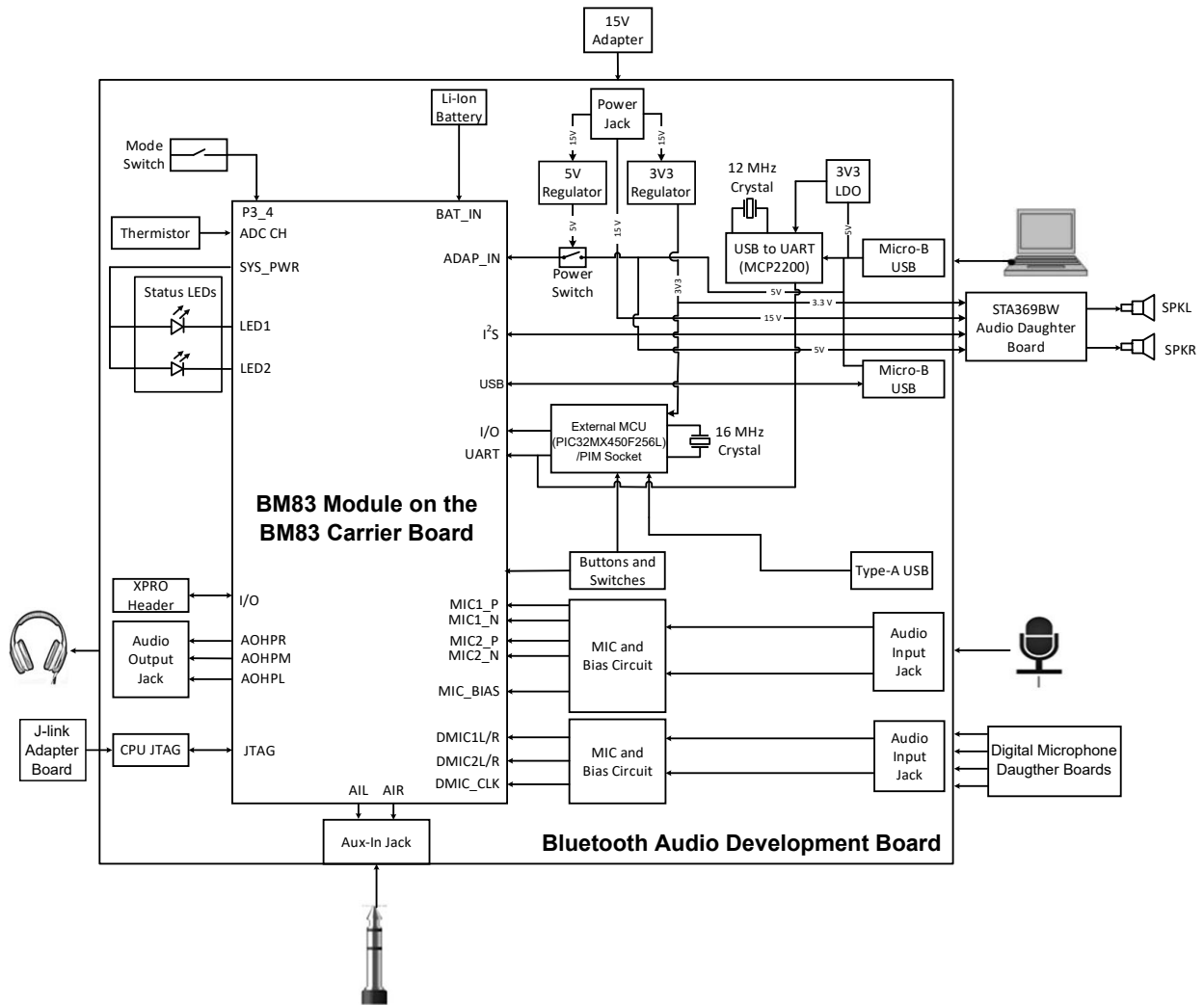

### 3.1 Hardware Features

The following sections provide detailed information on the BM83 EVB components. To locate these components in the BM83 EVB, refer to [Figure 2-1](#) and [Figure 3-2](#).

**Figure 3-2. BM83 EVB Switches, LEDs and Jumpers**

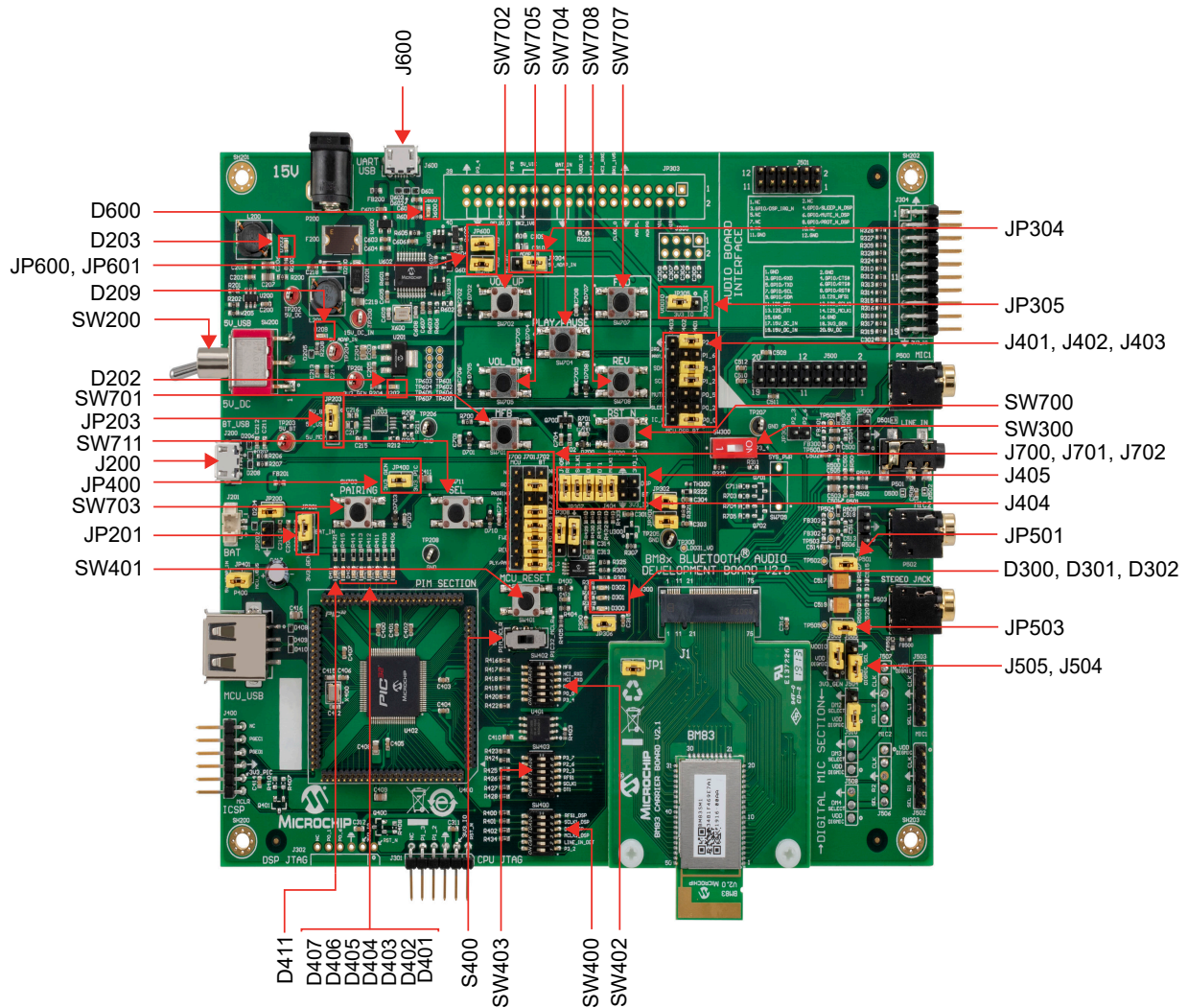

**Legends:** Dxxx - LEDs      JPxxx/Jxxx - Jumpers      Sxxx/SWxxx - Switches/Push buttons

#### 3.1.1 Power Supply

The BM83 EVB can be powered using any one of the following:

- Li-ion battery (J201) – When using a battery input, mount a jumper on the JP200 and pin 1 and 2 of the JP201. Do not mount a jumper on the JP202. The JP202 is a provision for connecting a battery power source with a 2.54 mm connector.
- 15V DC power adapter (P200)
- USB (J200 and J600) – A USB cable is connected to the PC, which provides 5V (USB\_5V).

### Notes:

1. The power switch (SW200) is used to switch between the two 5V power sources available on the board:
  - 5V\_DC: derived from the 15V DC
  - 5V\_USB: supplied by the 5V USB source
2. To locate these power sources available on the BM83 EVB, refer to [Figure 2-1](#).

### 3.1.2 USB Connectivity

The USB ports for BM83 EVB are:

- Micro-B USB port (J600 UART USB) – USB signals are converted to UART by the serial converter MCP2200, which is connected to the BM83 module.
- Micro-B USB port (J200 BT\_USB) – USB signals are directly connected to the BM83 module.
- Type A USB port (P400- MCU\_USB) – USB signals are directly connected to the host MCU (PIC32MX450F256L).

**Note:** To locate these USB ports available on the BM83 EVB, refer to [Figure 2-1](#).

### 3.1.3 Switches and Push Buttons

The functions of the switches and push buttons on the BM83 EVB are:

- S400 – Switch to select between the on-board PIC32 MCU or external Plug-in Module (PIM)
- SW200 – Power switch to switch between the 5V\_DC and 5V\_USB
- SW300 – Mode selection switch for configuring the BM83 module into Application mode or Test mode
- SW400 – Microcontroller-to-Bluetooth control switch
- SW401 – Reset button for the host MCU (MCU\_RESET)
- SW402 – Microcontroller-to-Bluetooth control switch
- SW403 – Microcontroller-to-Bluetooth control switch
- SW700 – Reset button for the BM83 module (RST\_N)
- SW701 – Multi-function button (MFB)
- SW702 – Increase volume (VOL\_UP)
- SW703 – Enter into pairing mode (PAIRING)
- SW704 – Play or pause the audio playback (PLAY/PAUSE)
- SW705 – Decrease volume (VOL\_DN)
- SW707 – Skip the audio track forward (FWD)
- SW708 – Skip the audio track backward (REV)
- SW711 – Select button (SEL), turns on the system and puts the system into Pairing mode during Host MCU mode application demonstration

**Note:** To locate these switches and push buttons available on the BM83 EVB, refer to [Figure 3-2](#).

The following table provides the settings for the mode selection switch (SW300) for configuring the BM83 module in various operating modes.

**Table 3-1. Mode Selection Switch (SW300) Details**

Mode	Pin Description
Test mode	SW300 is placed in ON (P3_4: Low) position
Application mode	SW300 is placed in OFF (P3_4: Floating) position

### 3.1.4 LEDs

All the on-board LEDs are categorized into three main types:

- Power LEDs:
  - Red (D600 and D202)
  - Green (D209 and D203)
- LEDs driven by the BM83 module:

- Red (D301)
- Blue (D300)
- Host MCU (PIC32)-related LEDs:
  - Green (D401-D407)
  - Green (D411)

**Note:** To locate these LEDs available on the BM83 EVB, refer to [Figure 3-2](#).

### 3.1.5 Headers

The following headers are available on the BM83 EVB.

**Note:** To locate these headers available on the BM83 EVB, refer to [Figure 2-1](#).

#### 3.1.5.1 I2S Header

I2S header (J405) provides the interface to connect an STA369BW Audio Daughter Board to the BM83 module. The following table provides the pin details of I2S header.

**Table 3-2. I2S Header (J405) Pin Details**

Pin Number	Pin Name
1	RFS1
2	SCLK1
3	DR1
4	DT1
5	MCLK1
6	GND
7	3V3_IO

**Note:**

1. Connect J405 and J404 to enable I2S interface with the STA369BW Audio Daughter Board.

#### 3.1.5.2 Audio Daughter Board Interface Header

The Audio Daughter Board interface headers (J500 and J501) provide the interface to use the STA369BW Audio Daughter Board. [Table 3-3](#) and [Table 3-4](#) provide the pin details of these headers.

**Table 3-3. Audio Daughter Board Interface Header (J500) Pin Details**

Pin Number	Pin Name	Pin Number	Pin Name
1	GND	11	I2S_DR1
2	GND	12	I2S_SCLK1
3	GPIO/RxD	13	I2S_DT1
4	GPIO/CTS#	14	I2S_MCLK1
5	GPIO/TxD	15	GND
6	GPIO/RTS#	16	GND
7	GPIO/SCL	17	15V_DC_IN
8	GPIO/RST#	18	3V3_GEN
9	GPIO/SDA	19	15V_DC_IN
10	I2S_RFS1	20	5V_DC

**Table 3-4. Audio Daughter Board Interface Header (J501) Pin Details**

Pin Number	Pin Name	Pin Number	Pin Name
1	NC	7	NC
2	NC	8	GPIO/PROT_N_DSP
3	GPIO/DSP_IRQ_N	9	NC
4	GPIO/SLEEP_N_DSP	10	NC
5	NC	11	GND
6	GPIO/MUTE_N_DSP	12	GND

### 3.1.5.3 Audio Control Button Headers

The audio control button headers (J700, J701 and J702) provide the mechanism to control the audio function buttons either by the BM83 module (Embedded mode) or on-board PIC32 MCU (Host MCU mode). The following tables provide the header pin description Embedded and Host MCU mode configurations.

**Table 3-5. Audio Control Button Headers (J700, J701 and J702) Pin Description <sup>(1)</sup>**

Pin Number	Pin Name	Description
1	PLY/PAU	Play or pause
2	REV	Reverse
3	FWD	Forward
4	VOL-	Volume down
5	VOL+	Volume up
6	PAIRING	Used for pairing the module with a smartphone (only for Host MCU mode)
7	Sel	Not used
8	NC	Not connected

**Note:**

1. To locate these headers on the BM83 EVB, refer to [Figure 2-1](#).

**Table 3-6. Embedded Mode Audio Control Button Header Configurations (J700, J701 and J702) <sup>(1)</sup>**

Pin Number	Jumper Names and Positions			Description
	J700	J701	J702	
1	Open	Mount a jumper on the J701 and J702		Audio streaming is controlled by the BM83 module in Embedded mode.
2	Open	Mount a jumper on the J701 and J702		
3	Open	Mount a jumper on the J701 and J702		
4	Open	Mount a jumper on the J701 and J702		
5	Open	Mount a jumper on the J701 and J702		
6	Open	Open	Open	
7	Open	Mount a jumper on the J701 and J702		
8	Open	Open	Open	

**Note:**

1. To locate these headers on the BM83 EVB, refer to [Figure 2-1](#).

**Table 3-7. Host MCU Mode Audio Control Button Header Configurations (J700, J701 and J702) <sup>(1)</sup>**

Pin Number	Jumper Names and Positions			Description
	J700	J701	J702	
1	Mount a jumper on the J700 and J701		Open	Audio streaming is controlled by the on-board PIC32MX450F256L MCU in Host MCU mode.
2	Mount a jumper on the J700 and J701		Open	
3	Mount a jumper on the J700 and J701		Open	
4	Mount a jumper on the J700 and J701		Open	
5	Mount a jumper on the J700 and J701		Open	
6	Mount a jumper on the J700 and J701		Open	
7	Mount a jumper on the J700 and J701		Open	
8	Open	Open	Open	

**Note:**

1. To locate these headers on the BM83 EVB, refer to [Figure 2-1](#).

### 3.1.5.4 BM83 Carrier Board Interface

The following table provides the pin details of J300 and the BM83 module interface with the BM83 EVB.

**Table 3-8. Carrier Board Interface (J300) Pin Details**

Pin Name	Pin Number		Pin Name
BK1_O_1V5	1	2	MCLK1
LED3	3	4	DT1
NC	5	6	DR1
RST_N	7	8	SCLK1
DP	9	10	RFS1
DM	11	12	GND
GND	13	14	P3_7
GND	15	16	P3_5
P2_7	17	18	NC
P1_3	19	20	BK2_O_1V8
P1_2	21	22	NC
P0_5	23	24	P0_1
P0_2	25	26	P0_0
P0_3	27	28	P2_3
P0_6	29	30	P0_7
LED2	31	32	UART_TXD
P1_6	33	34	UART_RXD
LED1	35	36	SK2_KEY_AD



.....continued

Pin Name	Pin Number		Pin Name
P3_4	37	38	PWM
SK1_AMB_DET	39	40	MFB
NA	41	42	DMIC2_R
NA	43	44	DMIC2_L
P3_2	45	46	VDD_IO
GND	47	48	SYS_PWR
MIC_BIAS	49	50	BAT_IN
MIC_P1	51	52	ADAP_IN
MIC_N1	53	54	NC
AIL	55	56	P2_6
AIR	57	58	DMIC1_R
MIC_P2	59	60	DMIC1_L
MIC_N2	61	62	DMIC_CLK
AOHPL	63	64	GND
AOHPM	65	66	GND
AOHPR	67	—	—

### 3.1.5.5 ICSP Header

The ICSP header (J400) provides the programming/debugging interface for the on-board PIC32 MCU (PIC32MX450F256L). To locate this header on the BM83 EVB, refer to [Figure 2-1](#). The following table provides the ICSP header pin description.

**Table 3-9. ICSP Header (J400) Pin Description**

Pin Number	Description
1	Reset (MCLR)
2	Power supply (3V3_PIC)
3	Ground (GND)
4	Data (PGED1)
5	Clock (PGEC1)
6	Not connected (NC)

### 3.1.5.6 Xplained PRO Header

The BM83 EVB provides the 20-pin XPRO header (J304) needed to interface with the XPRO platform. The following table provides the pin details of XPRO header.

**Table 3-10. XPRO Header (J304) Pin Details**

Pin Name	Pin Number		Pin Name
NC	1	2	GND
SK2_KEY_AD	3	4	SK1_AMB_DET
NA	5	6	NA



.....continued

Pin Name	Pin Number		Pin Name
PWM	7	8	P0_0
P0_6	9	10	P3_5
P1_3	11	12	P1_2
UART_RXD	13	14	UART_TXD
P0_7	15	16	P2_6
P2_3	17	18	P1_6
GND	19	20	3V3_IO

### 3.1.5.7 Digital Microphone Headers

The 5-pin digital microphone header provides an interface to the BM83 EVB and the Digital Microphone Daughter Board. The pin description is provided in the following table.

**Table 3-11. Digital Microphone Headers (J1, J503 and J502) Pin Description** (1, 2, 3, 4)

Pin Number	Digital Microphone Daughter Board	BM83 EVB		Pin Description
	Pin Name (J1)	Pin Name (J503)	Pin Name (J502)	
1	VDD	VDD DIGMIC	VDD DIGMIC	Power supply from the BM83 EVB
2	CLOCK	DMIC1_CLK	DMIC1_CLK	Clock input to the microphone from the BM83 module
3	GND	GND	GND	Ground
4	DATA	DMIC1_L	DMIC1_R	PDM output from the microphone to the BM83 module
5	SEL	DM1 SELECT	DM2 SELECT	Select the input for the microphone

## 4. Embedded Mode Quick Demo

This section provides a quick demo on streaming audio using the BM83 module in Embedded mode.

Perform the following steps:

**Note:** The BM83 EVB is preconfigured for the Embedded mode quick demo.

1. Unbox the kit and connect the speaker cables to the STA369BW Audio Daughter Board at CN1 and CN2, and connect the cables to the speaker.

**Figure 4-1. Speakers Connected to the STA369BW Audio Daughter Board**

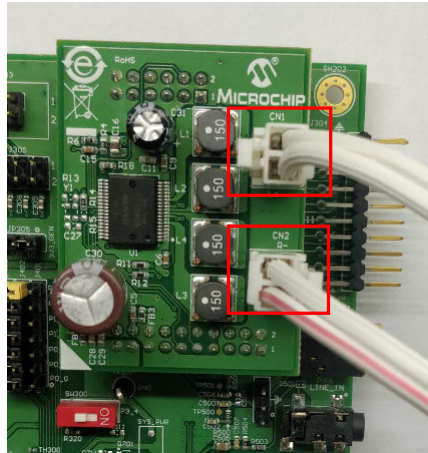

2. The SW200 switch is set to the 5V\_USB position, as shown in the following figure.

**Figure 4-2. SW200 Switch Position**

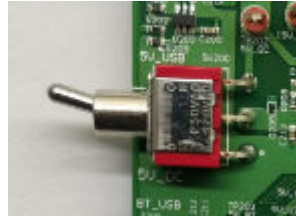

3. Connect the 15V DC adapter at the DC power jack P200. Notice that the Green LED (D203) and Red LED (D202) turn ON.
4. Set the SW200 switch to the 5V\_DC position. Notice that the Green LED (D209) turns ON.
5. Long press the **MFB** button (SW701) for a minimum of 4-5 seconds until the Blue LED (D300) and Red LED (D301) start blinking alternately. Observe the sound from the speakers.
6. Release the **MFB** button.
7. Perform the following steps to pair the BM83 module with a smartphone:
  - 7.1. Turn ON the smartphone's Bluetooth to scan for the available devices.
  - 7.2. Tap on "MCHP BM83" from the scan results. Pair to connect the device.
  - 7.3. On successful pairing, the MCHP BM83 device must be visible under the "PAIRED DEVICES", as shown in the following figure.

Figure 4-3. Pairing and Connection

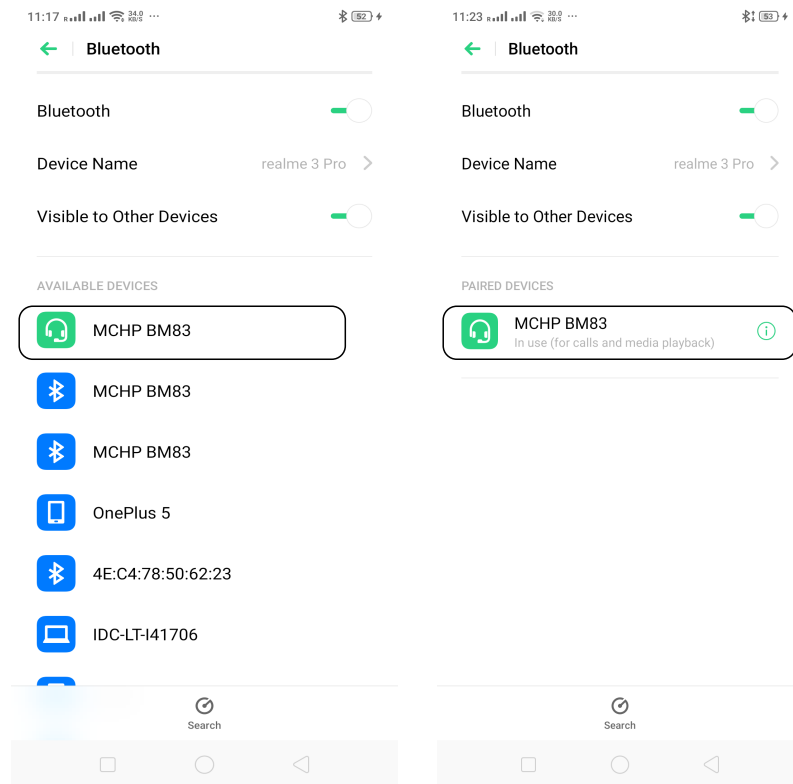

- 7.4. Stream the audio from the smartphone to the BM83 module over the Bluetooth connection and listen to it over the speakers.
8. Control the audio with the following buttons:
  - 8.1. Press the **VOL\_UP** button (SW702) to increase the volume.
  - 8.2. Press the **VOL\_DN** button (SW705) to reduce the volume.
  - 8.3. Press the **Play** button (SW704) to play the audio.
  - 8.4. Press the **Pause** button (SW704) to pause the audio.
  - 8.5. Press the **FWD** button (SW707) to jump to the next audio file.
  - 8.6. Press the **REV** button (SW708) to jump to the previous audio file.
  - 8.7. Press the **MFB** button (SW701) for a minimum of 4-5 seconds to turn OFF the system.

## 5. Firmware Update

This section describes the firmware update of the BM83 module over UART and USB DFU.

### 5.1 Firmware Update over UART

To update the firmware of the BM83 module, the user must ensure the hardware settings and configurations match those described in the following table.

**Table 5-1. BM83 EVB Firmware Update Settings <sup>(1)</sup>**

Jumpers and Switches <sup>(1)</sup>	Description
JP600 and JP601	<ul style="list-style-type: none"> <li>Mount a jumper on the JP600 (TXD)</li> <li>Mount a jumper on the JP601 (RXD)</li> </ul>
JP304	Mount a jumper on the “ADAP_IN” and “5V_ADAP_IN” pins of the JP304 pin2 and pin3
JP203	Mount a jumper on the 5V_USB and 5V_MCP pins of the JP203 pin2 and pin3
SW300	Put the SW300 switch to the ON position for Test mode
SW200	Put the SW200 switch to the 5V_USB position
JP305	Mount a jumper on the “3V3_IO” and “VDDIO” pins of the JP305
J600	Connect the USB cable from a PC to the J600

**Note:**

- To locate these jumpers, switches and power sources on the BM83 EVB, refer to [Figure 3-2](#) and [Figure 2-1](#).

Perform the following steps to load the firmware files onto the BM83 module using the isUpdate tool.

**Note:** Download the isUpdate tool from [www.microchip.com/BM83](http://www.microchip.com/BM83).

- Connect the BM83 EVB Micro-B USB port J600 over the USB cable to the PC.  
**Note:** Be sure to disconnect the 15V power supply before connecting the USB cable.
- Observe that the Red LED (D600), Green LED (D209) and Blue LED (D300) turn ON.
- Open the isUpdate tool. Select the appropriate COM port, set the baud rate to 115200 and image num to 1, as shown in the following figure.
- Click **Connect**.

Figure 5-1. isUpdate Tool Window

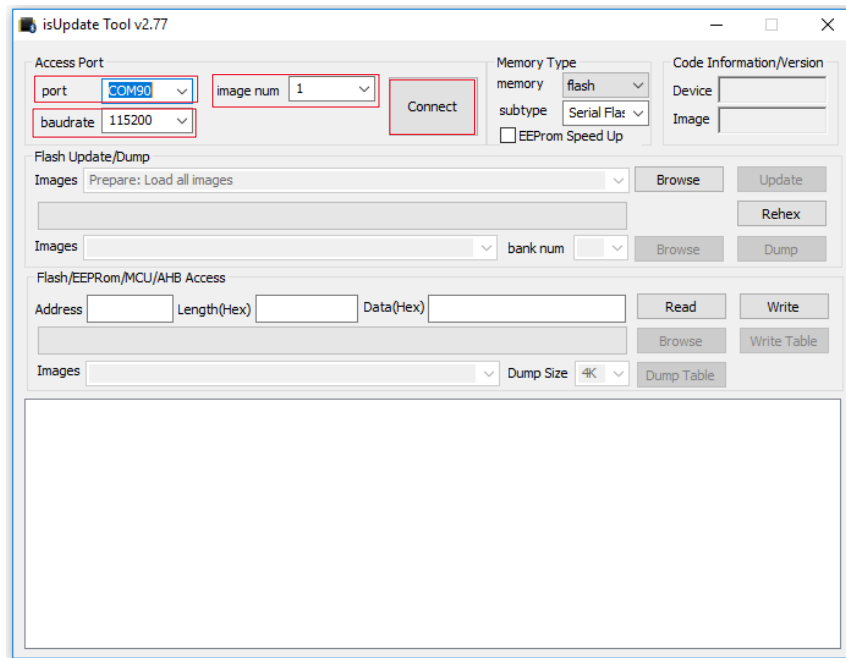

**Note:** In the isUpdate tool, the image num values must be equal to the number of images to be programmed on the device. For example, to program firmware (image1), DSP (image2) and configuration (image3), the image num value must be selected as 3.

5. The message on the console and the transition of the Connect button to Disconnect indicates that the connection is established successfully between the PC and the BM83 module.

Figure 5-2. Connection Established

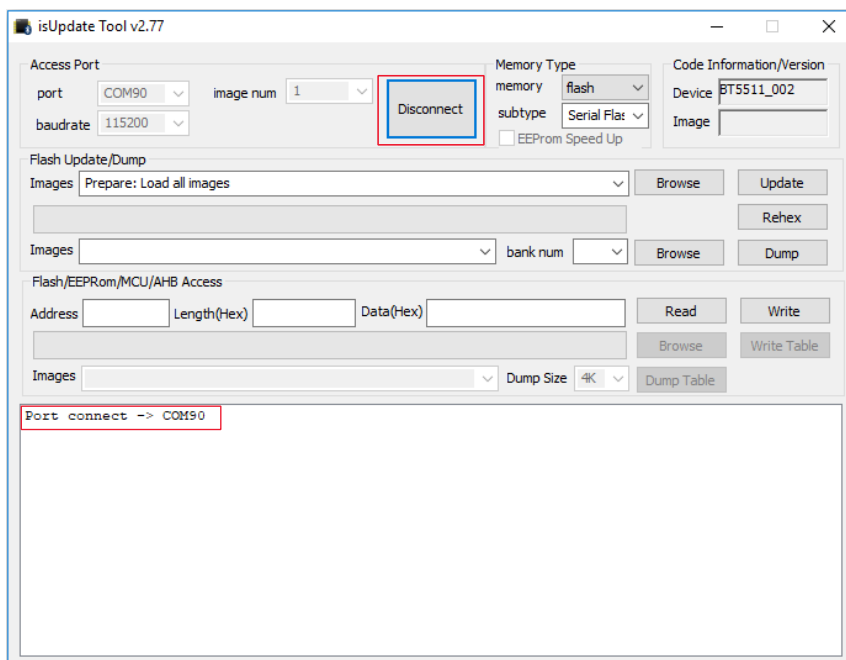

- Once the connection is established, click **Browse** and locate the firmware image provided in the release package.  
**Note:** The Embedded mode firmware images are available in the package. For more information, refer to [www.microchip.com/BM83](http://www.microchip.com/BM83).

**Figure 5-3. Browsing and Loading the Files**

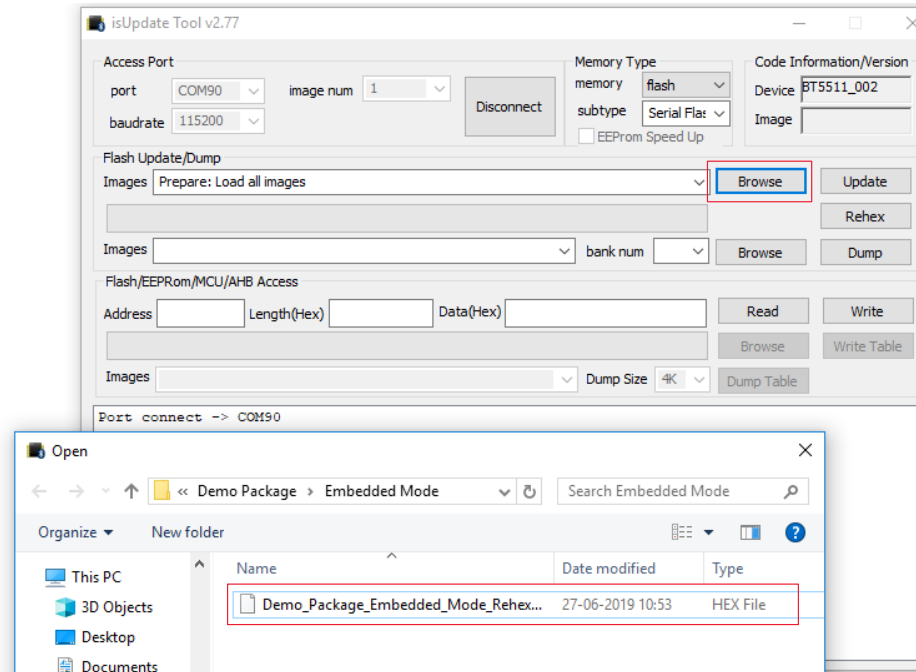

- Click **Update** to load the firmware to the BM83 module and observe the progress.

**Figure 5-4. Updating the Firmware**

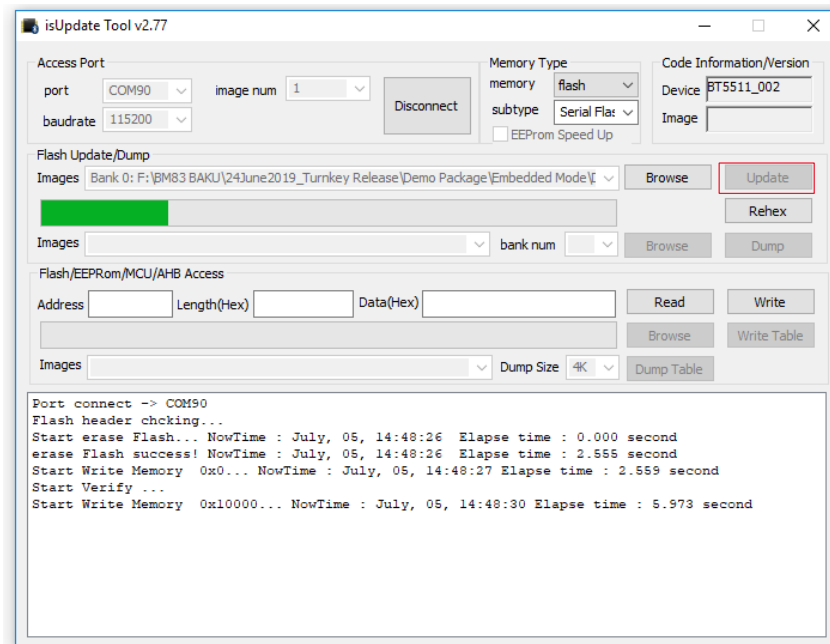

8. Click **Disconnect** and close the isUpdate tool after a successful firmware update.

**Figure 5-5. Process Completed**

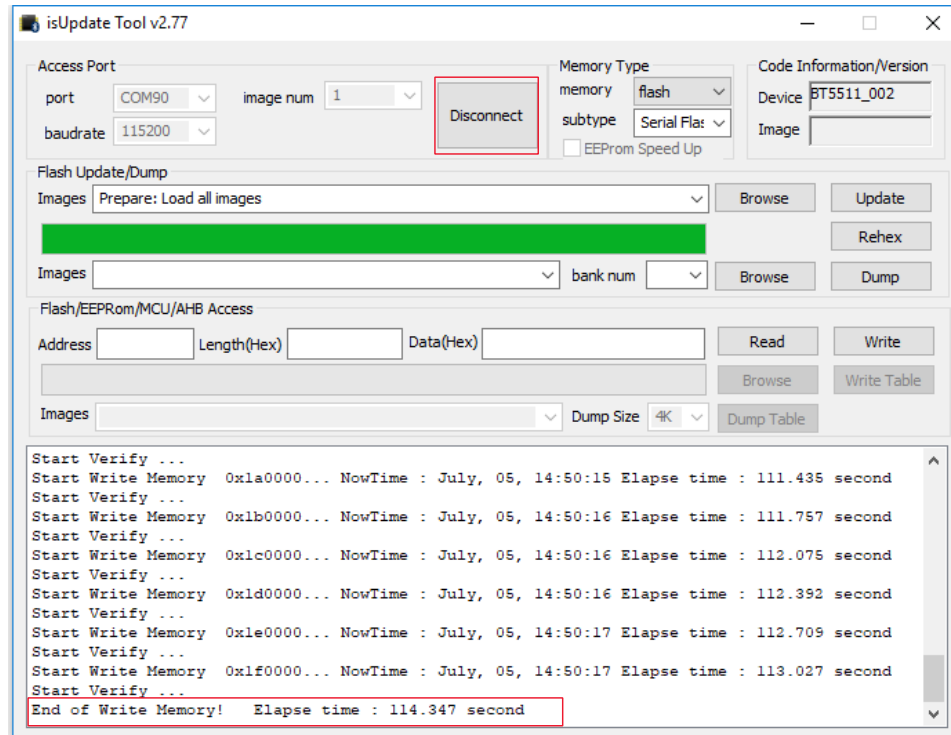

9. Remove the USB cable.

## 5.2 Firmware Update over USB

Use the isUpdate tool to perform a firmware update on the BM83 module through the USB Device Firmware Upgrade (DFU). The BM83 EVB must be in Application mode. To update the firmware over the USB, the user must ensure the hardware settings and configurations match those described in the following table.

**Table 5-2. BM83 EVB Firmware Update Settings**

Jumpers and Switches <sup>(1)</sup>	Description
JP304	Mount a jumper on the “ADAP_IN” and “5V_ADAP_IN” pins of the JP304 pin2 and pin3
JP203	Mount a jumper on the 5V_USB and 5V_BT pins of the JP203 pin1 and pin2
SW200	Put the SW200 switch to the 5V_USB position
SW300	Put the SW300 switch to the OFF position for Application mode
J200	Connect the USB cable from a PC to the J200
JP305	Mount a jumper on the “3V3_IO” and “VDD_IO” pins of the JP305

**Note:**

1. To locate these jumpers, switches and power sources on the BM83 EVB, refer to [Figure 3-2](#) and [Figure 2-1](#).

Perform the following steps to load the firmware files onto the BM83 module using the isUpdate tool. Ensure that the SW200 switch is in 5V\_DC before connecting the USB cable to the J200 USB port.

1. Connect the BM83 EVB Micro-B USB port J200 over the USB cable to the PC.  
**Note:** Be sure to disconnect the 15V power supply before connecting the USB cable.

2. Observe that the Green LED (D209) and Red LED (D202) turn ON.
3. Set the SW200 switch to 5V\_USB.
4. Open the isUpdate tool. Select the port as USB HID, set the baud rate to 115200 and image num to 1, as shown in the following figure.
5. Click **Connect**.

**Figure 5-6. Loading the Firmware Files**

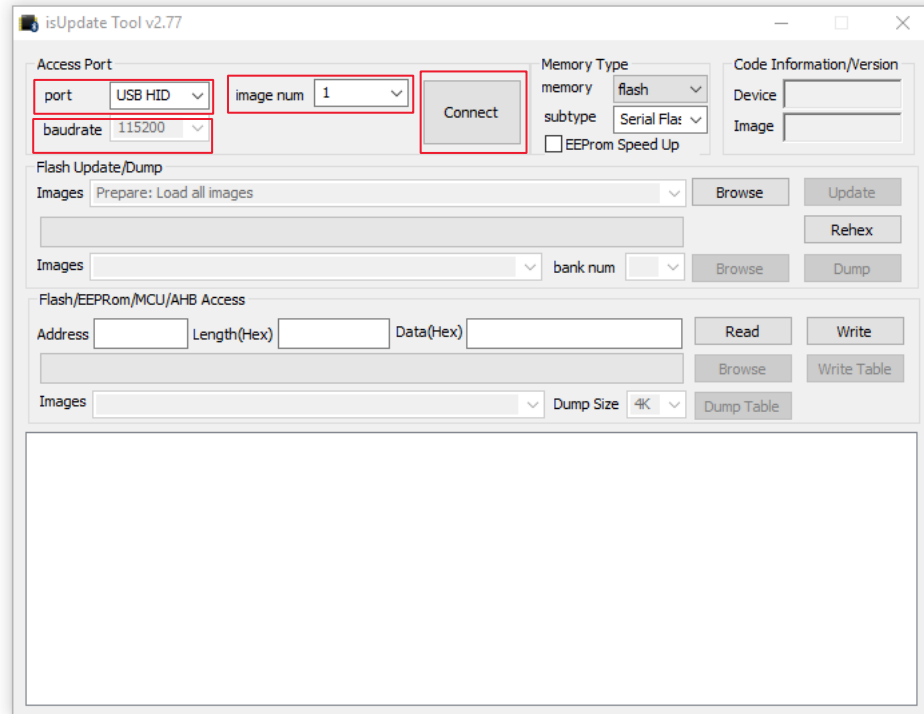

**Note:** In isUpdate tool, image num value must be equal to the number of images to be programmed on the device. For example, to program firmware (image1), DSP (image2) and configuration (image3), the image num value must be selected as 3.



- The message on the console and the transition of the Connect button to Disconnect indicates that the connection is established successfully between the PC and the BM83 module.

**Figure 5-7. Connection Established**

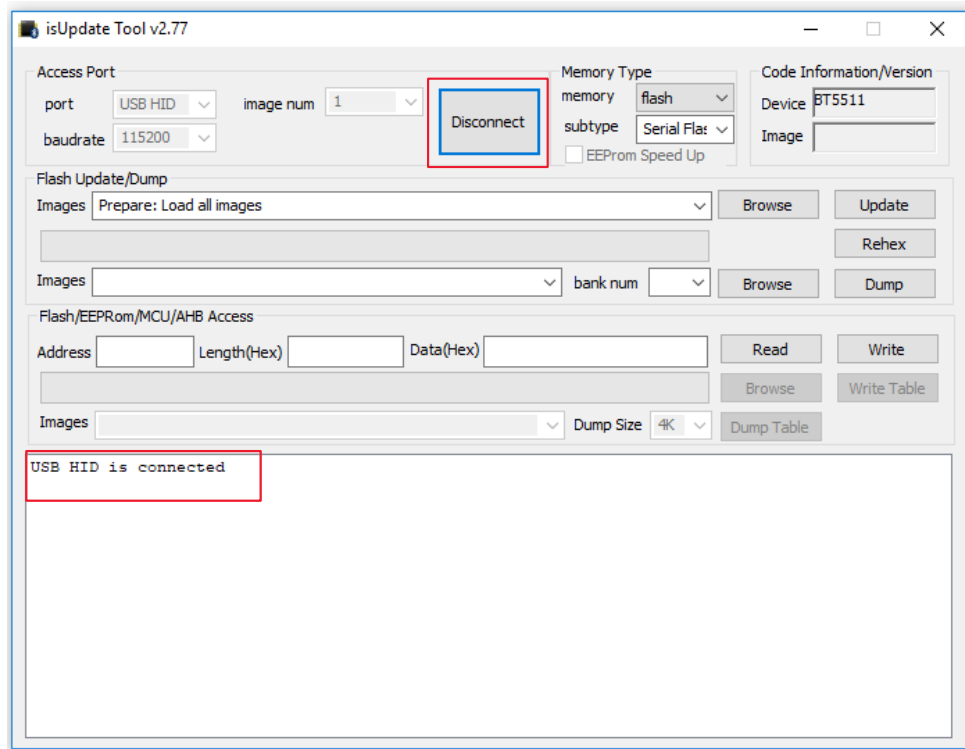

- Once the connection is established, click **Browse** and open the firmware image provided in the release package.  
**Note:** The Embedded mode firmware images are available in the package. For more information, refer to [www.microchip.com/BM83](http://www.microchip.com/BM83).

**Figure 5-8. Browsing and Loading the Files**

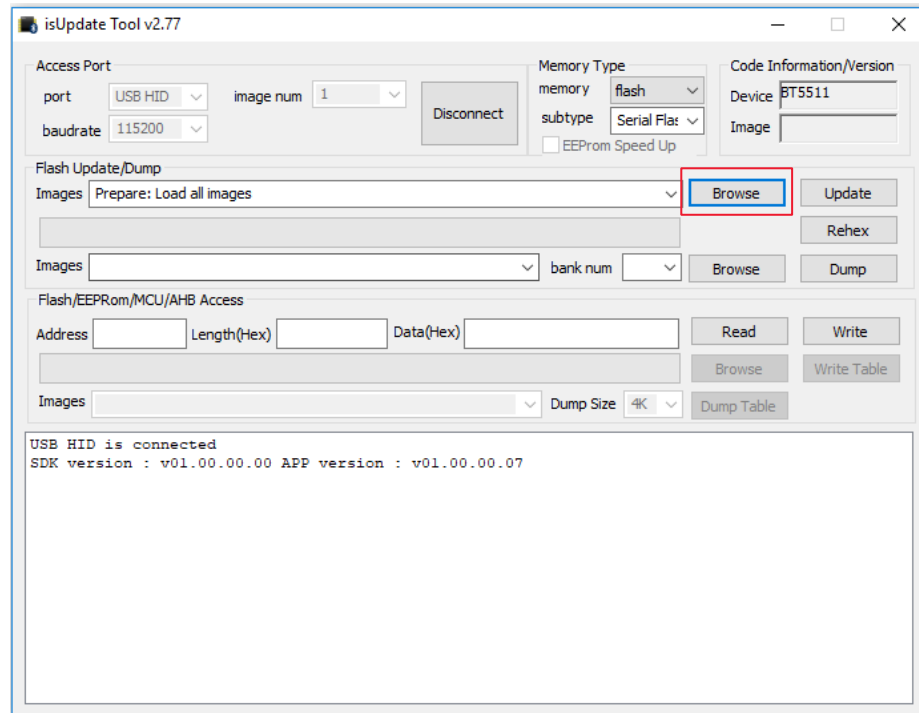

- Click **Update** to update the firmware and observe the progress.

**Figure 5-9. Updating the Firmware**

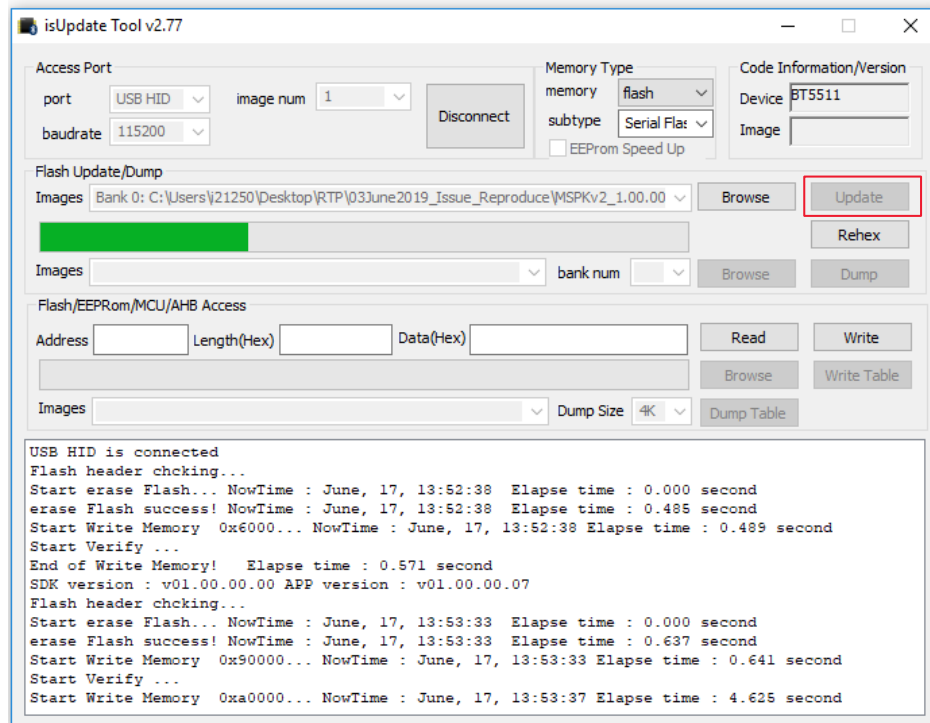

9. Click **Disconnect** and close the isUpdate tool after a successful firmware update.

**Figure 5-10. Process Completed**

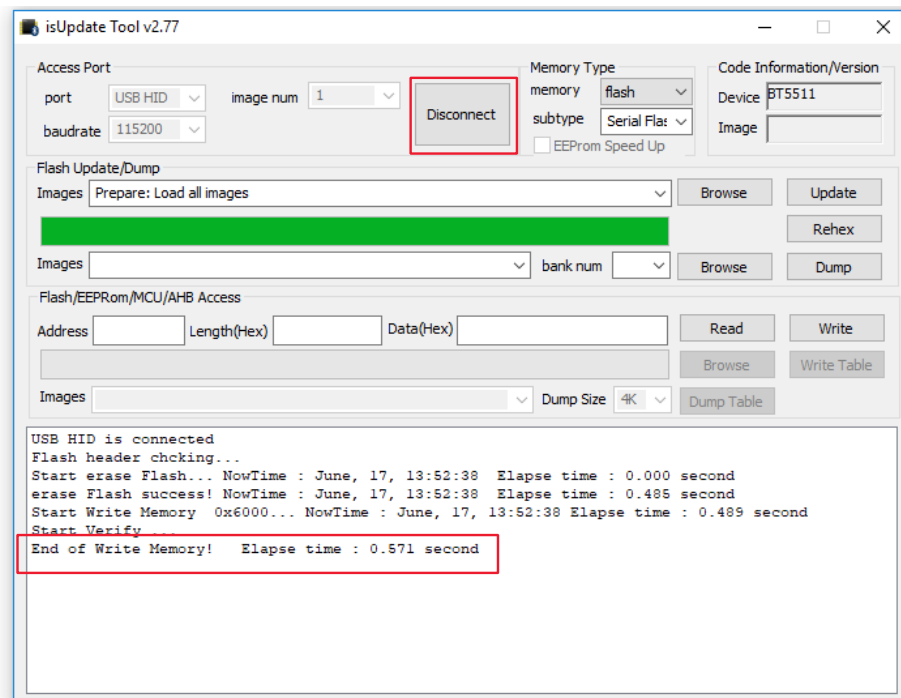

10. Remove the USB cable.

## 6. Customizing Module Parameters

### 6.1 Config Tool Setup

The IS208x\_Config\_GUI\_Tool Config Tool setup is a configuration tool that allows the user to change the BM83 module parameters such as device name, Bluetooth Low Energy connection settings, LED configuration, enable/disable Pairing mode and other functions.

**Note:** For this demonstration, Config Tool version IS208x\_Config\_GUI\_Tool v1.0.11 is used. Refer to the latest version at [www.microchip.com/BM83](http://www.microchip.com/BM83). For additional details on the Config Tool, refer to the *IS208x Config GUI Tool User's Guide*.

To configure the GUI parameters, perform the following steps:

1. Open the Config Tool and click **OK** to configure the parameters.

**Figure 6-1. Config Tool - Welcome Window**

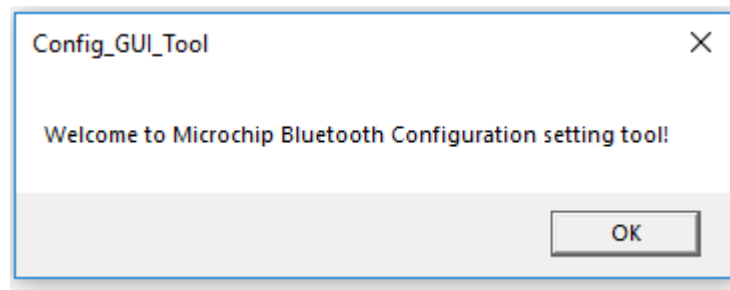

2. In the Config Tool, click **Load**.

**Figure 6-2. Config Tool**

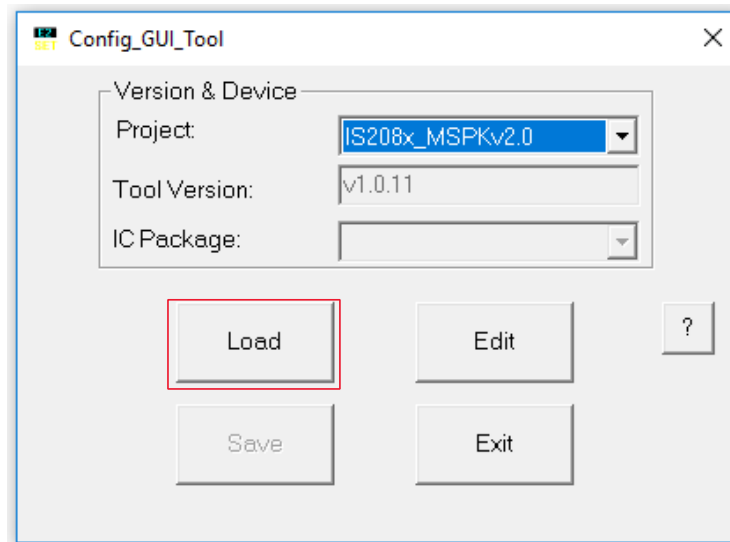

3. From the Open window, select the default GUI parameters file (provided with the UI tool) for this module (BM83), then click **Open**. Refer to the following figure.

**Figure 6-3. Loading Default GUI Parameters**

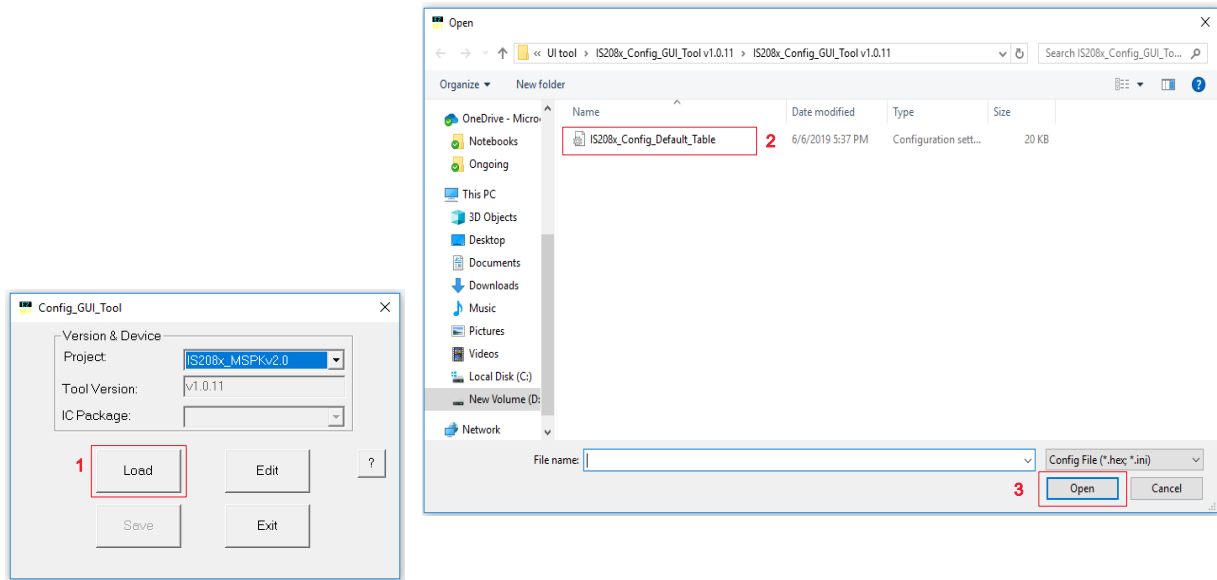

4. After loading the GUI parameters, click **Edit** to customize the GUI parameters on the Main Feature window.

**Figure 6-4. Editing Parameters**

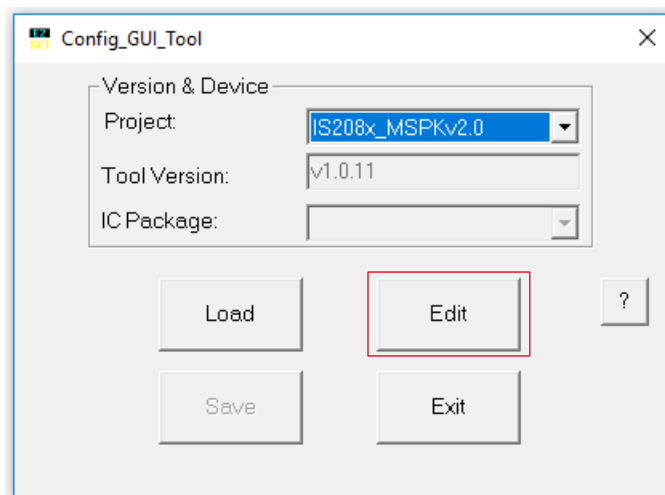

5. In the Main Feature window, the user can enable or disable the features required for their application. Select the “Embedded Mode” option (see [Figure 6-5](#)) and click **Next**.

**Notes:**

- For Host MCU mode, select “Host MCU Mode”.
- For Embedded mode, select “Embedded Mode”.

**Figure 6-5. Main Feature Settings**

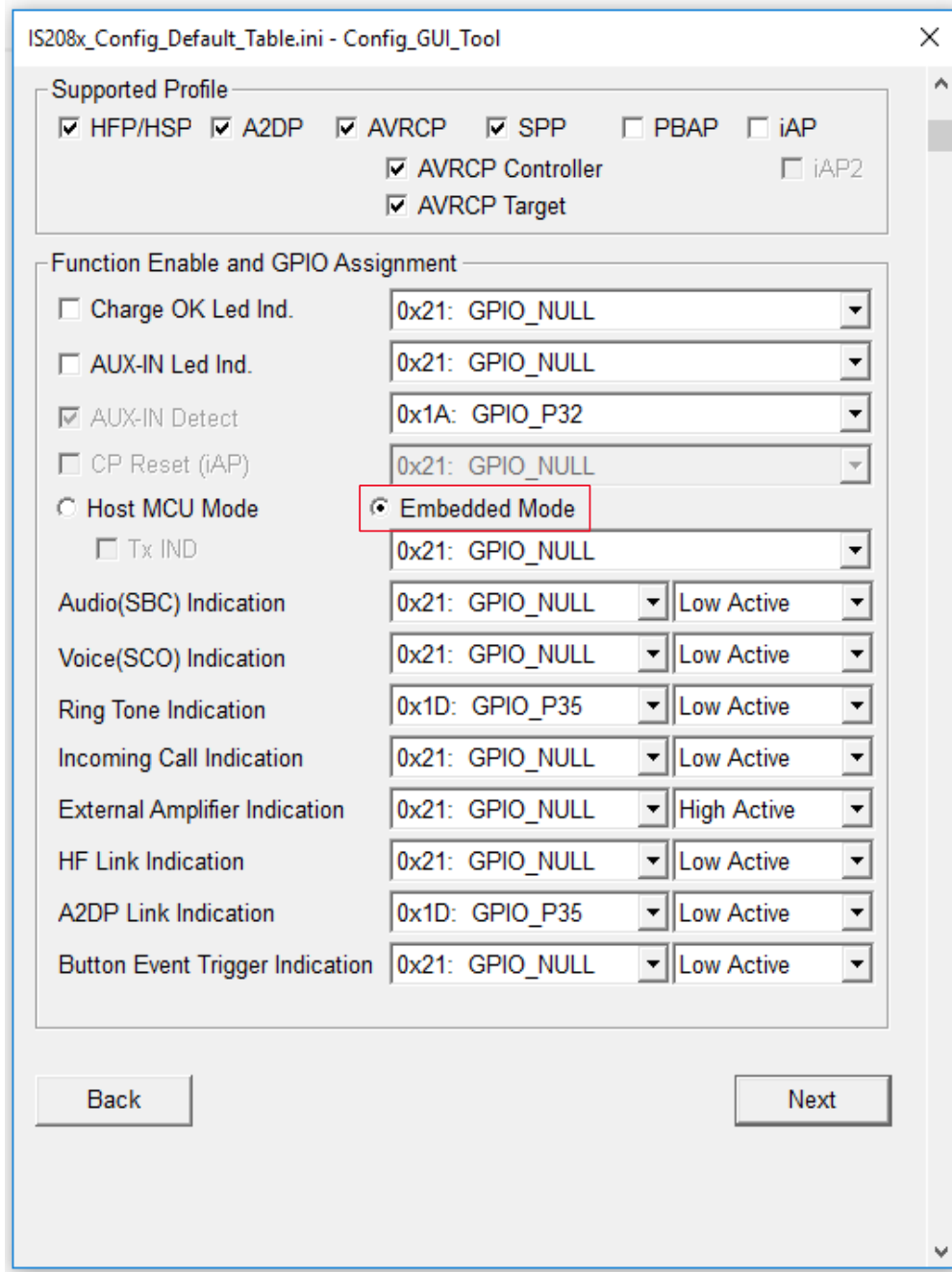

6. In the System and Functional Settings window, go to the **Sys. Setup1** tab to power ON/OFF the Bluetooth system. Select MFB Power ON/OFF in the “Power Switch Type” section.

**Figure 6-6. Options in Sys. Setup1 Tab**

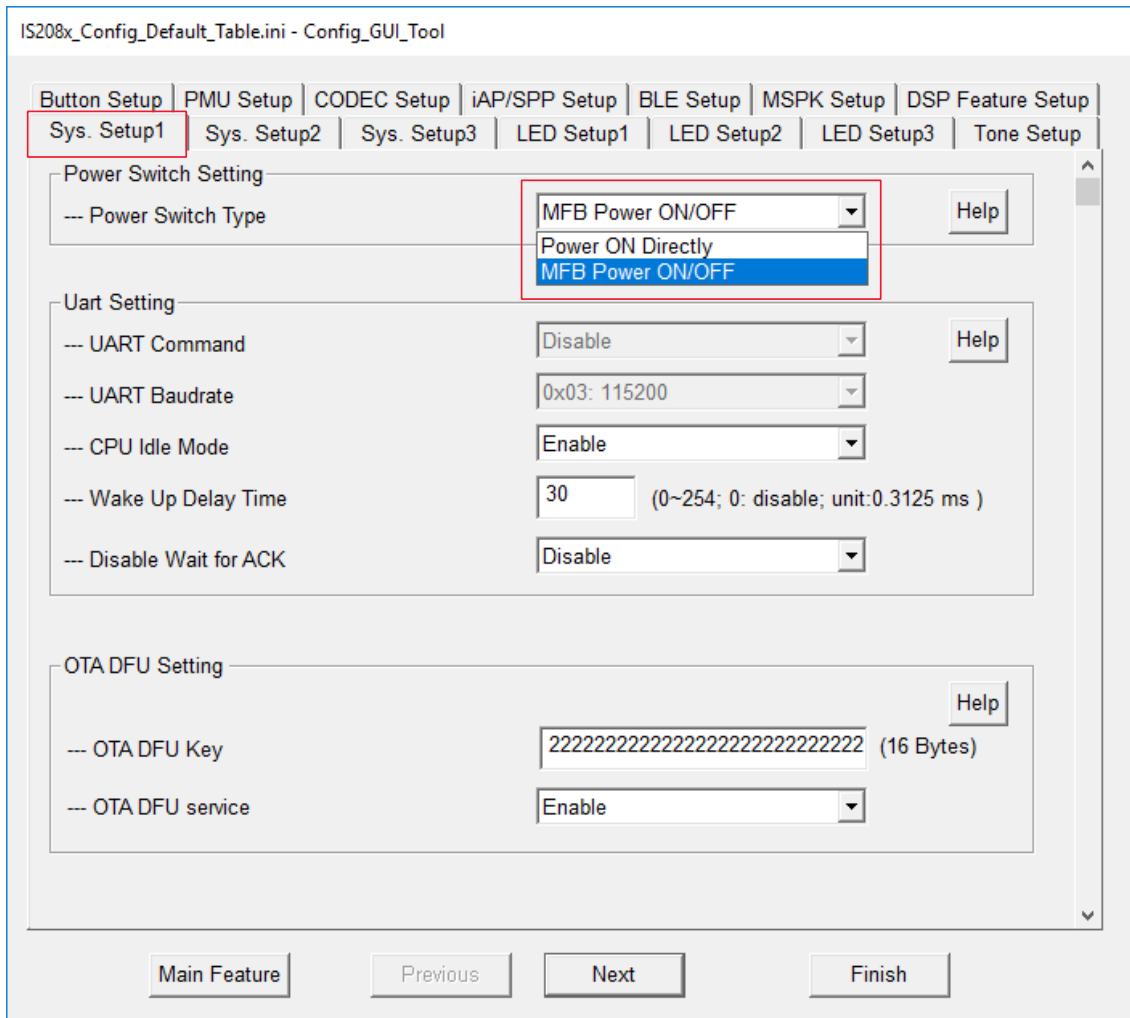

7. In the **Sys. Setup2** tab, the user can change the following, as shown in the [Figure 6-7](#):

- Device name – Add the device name in the text box in the “Name Frag Segment” section.
- Pairing mechanism – Select Enable for the pairing mechanism in the “Simple Pairing” drop-down menu.

**Figure 6-7. Options in Sys. Setup2 Tab**

The screenshot shows the configuration tool interface for IS208x. The 'Sys. Setup2' tab is active. The 'Name Frag Segment' section contains a text box with 'MCHP BM83' and a '(64 Char)' label. The 'Security' section has a 'Simple Pairing' dropdown menu set to 'Enable' and a 'PIN Code' text box with '0000'. The 'Misc Option' section has several dropdown menus: 'Enable Pairing as Standby Mode' (Disable), 'Enter Pairing Mode When Power On' (Disable), 'Suspend Stream When SCO Established' (Disable), 'Class of Device' (Speaker), 'Report Battery Status to Smart Phone' (Enable), 'Link Application' (Multi-Link), 'Always Answer Incoming Call' (Disable), 'Auto Answer Incoming Call When Link Back' (Disable), and 'Hang Up a Call When Switch Off' (Disable). Navigation buttons 'Main Feature', 'Previous', 'Next', and 'Finish' are at the bottom.



8. In the **CODEC Setup** tab, select Internal codec from the “CODEC Output Type” drop-down menu.

**Figure 6-8. Options in CODEC Setup Tab**

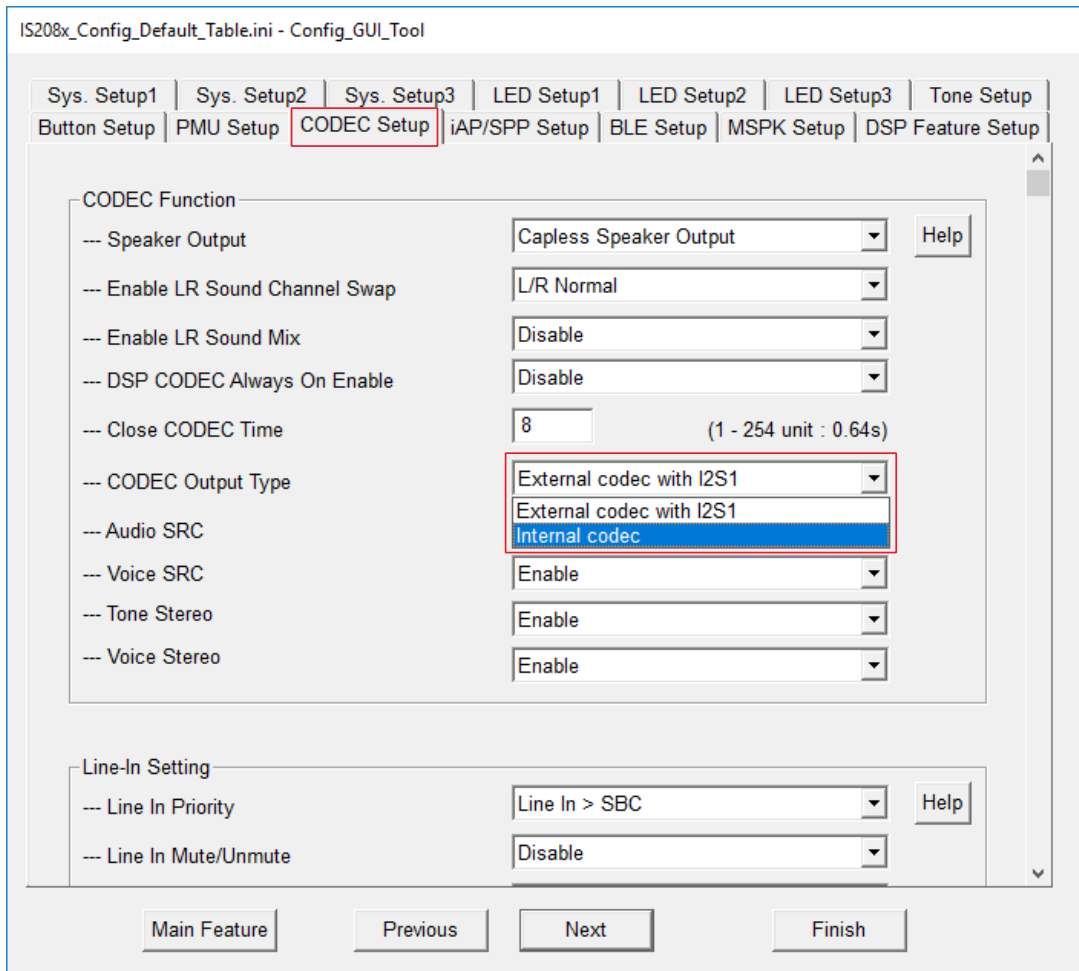

9. Click **Finish** after modifying these settings. The IS208x\_DSP\_GUI\_Tool window opens, as shown in the following figure.

**Figure 6-9. Main Function Tab**

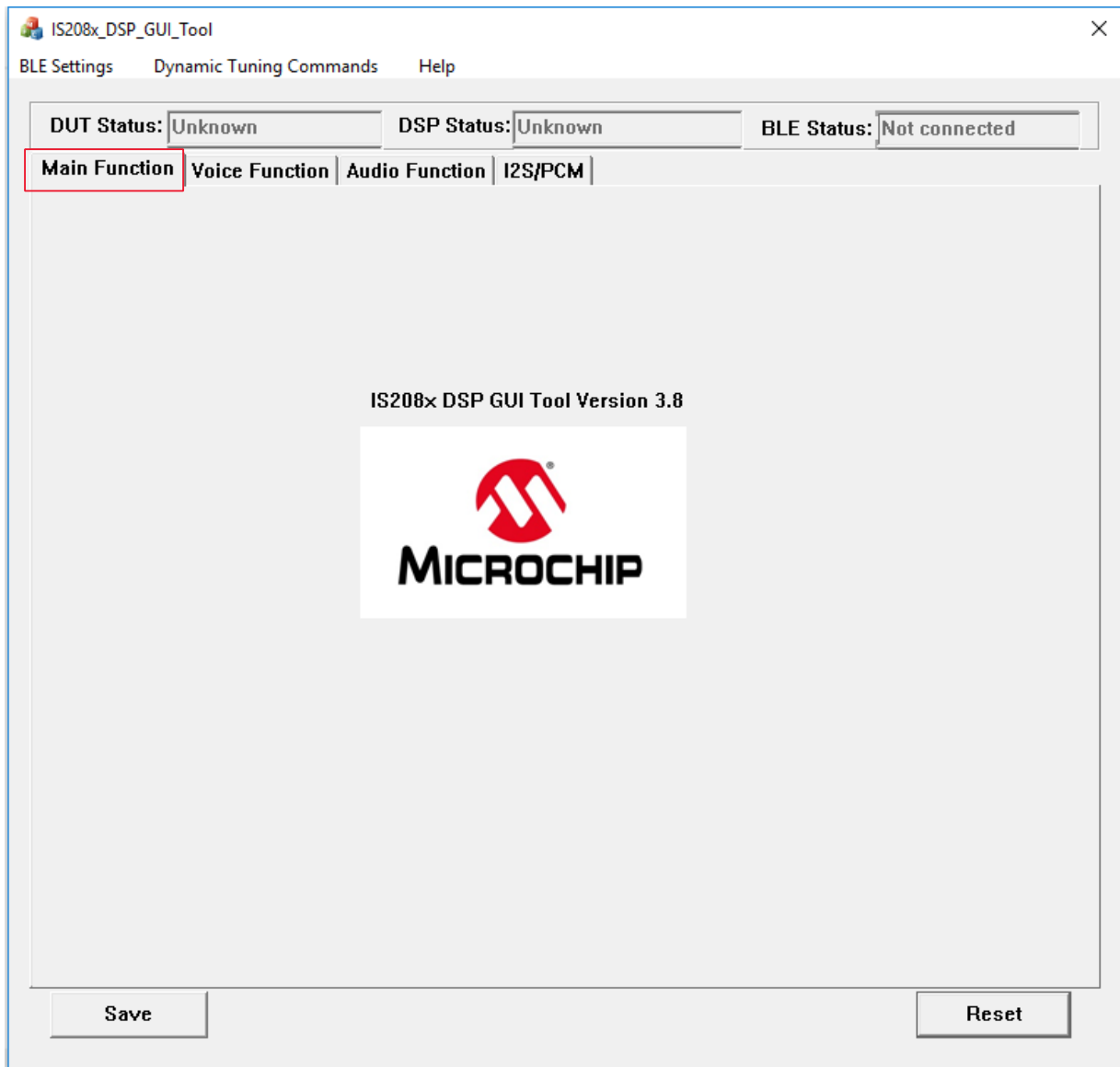

10. In the **Voice Function** tab, the user can set the required parameters, as shown in the following figure.

**Figure 6-10. Voice Function Tab**

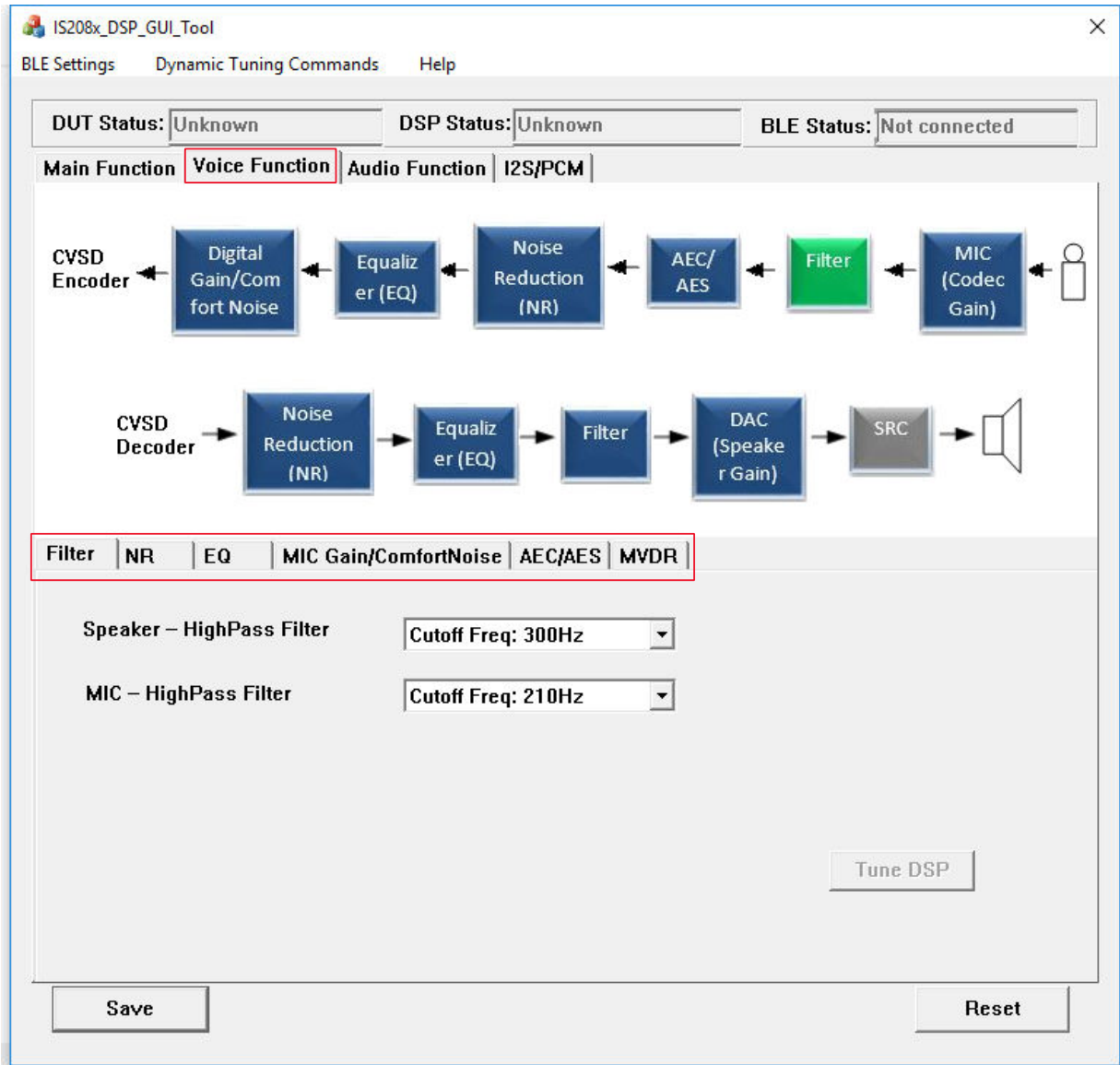

11. In the **Audio Function** tab, the user can set the required parameters, as shown in the following figure.

Figure 6-11. Audio Function Tab

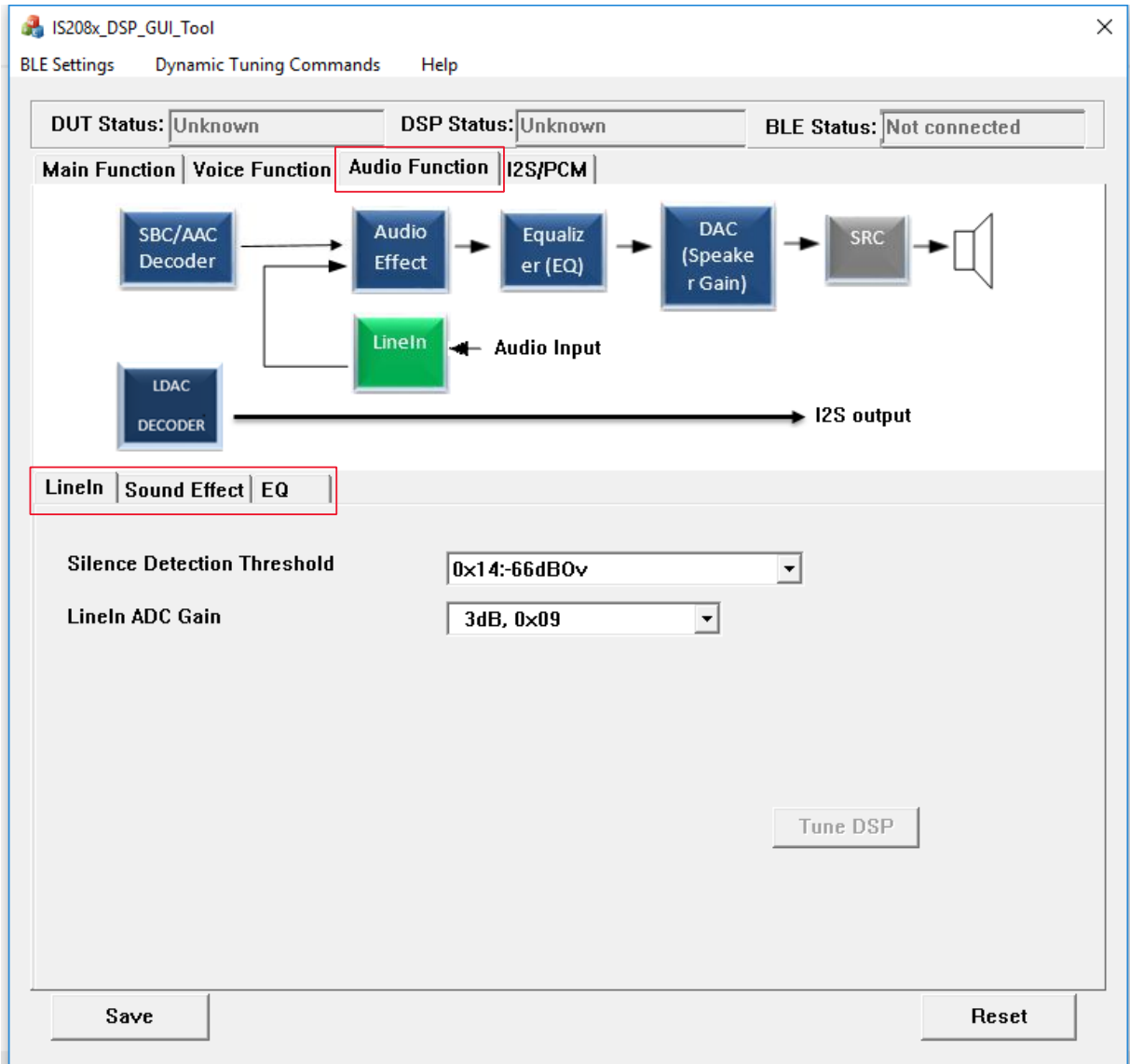

12. In the **I2S/PCM** tab, the user can set the required parameters, as shown in the following figure.

Figure 6-12. I2S/PCM Tab

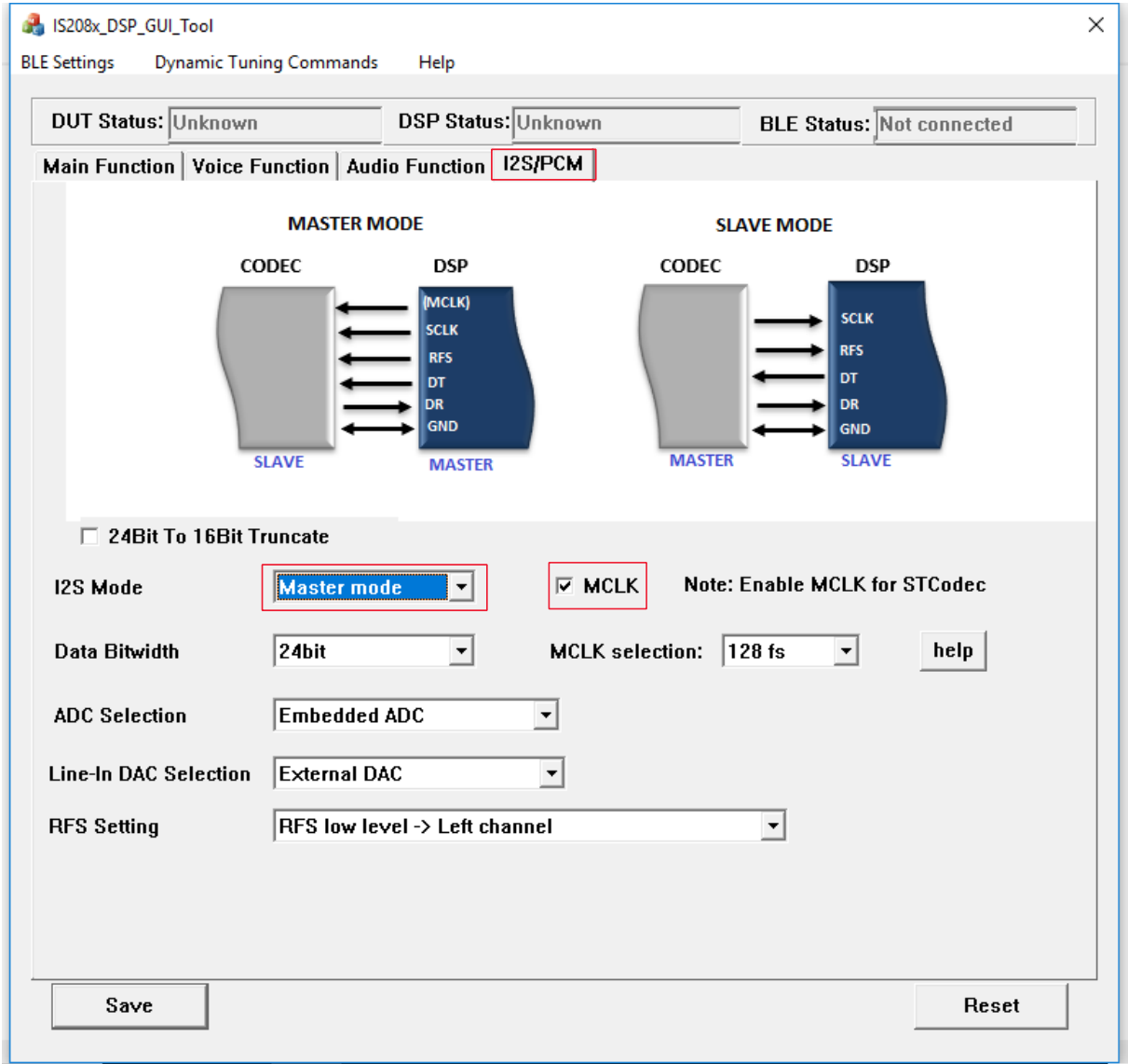

13. Click **Save** to save the changed parameters into a file and click **OK** on the confirmation window (see the following figure).

Figure 6-13. Saving Parameters

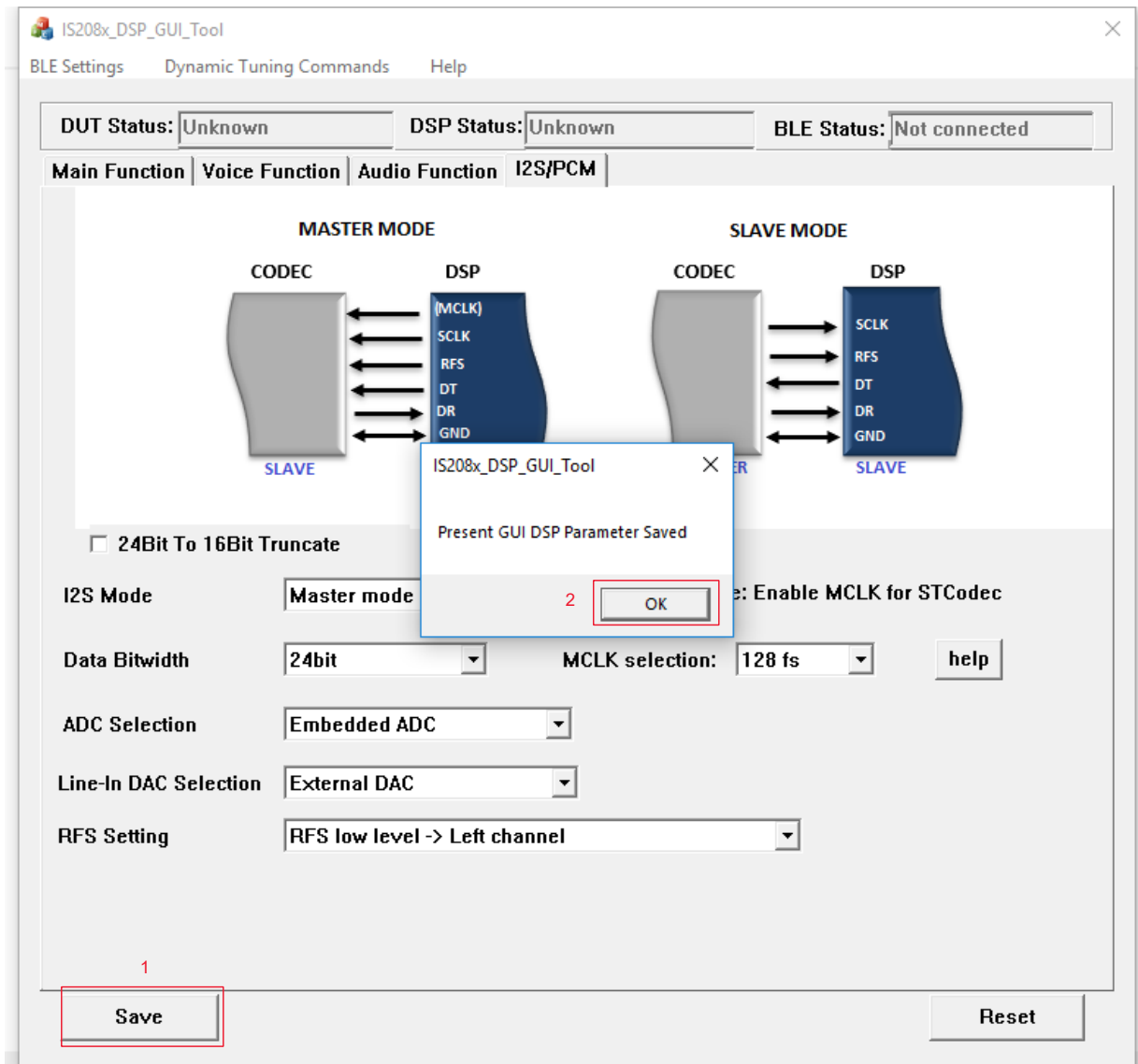

14. Click **Save** to save the file in .HEX format, as shown in the following figure.

**Figure 6-14. Save as a HEX File**

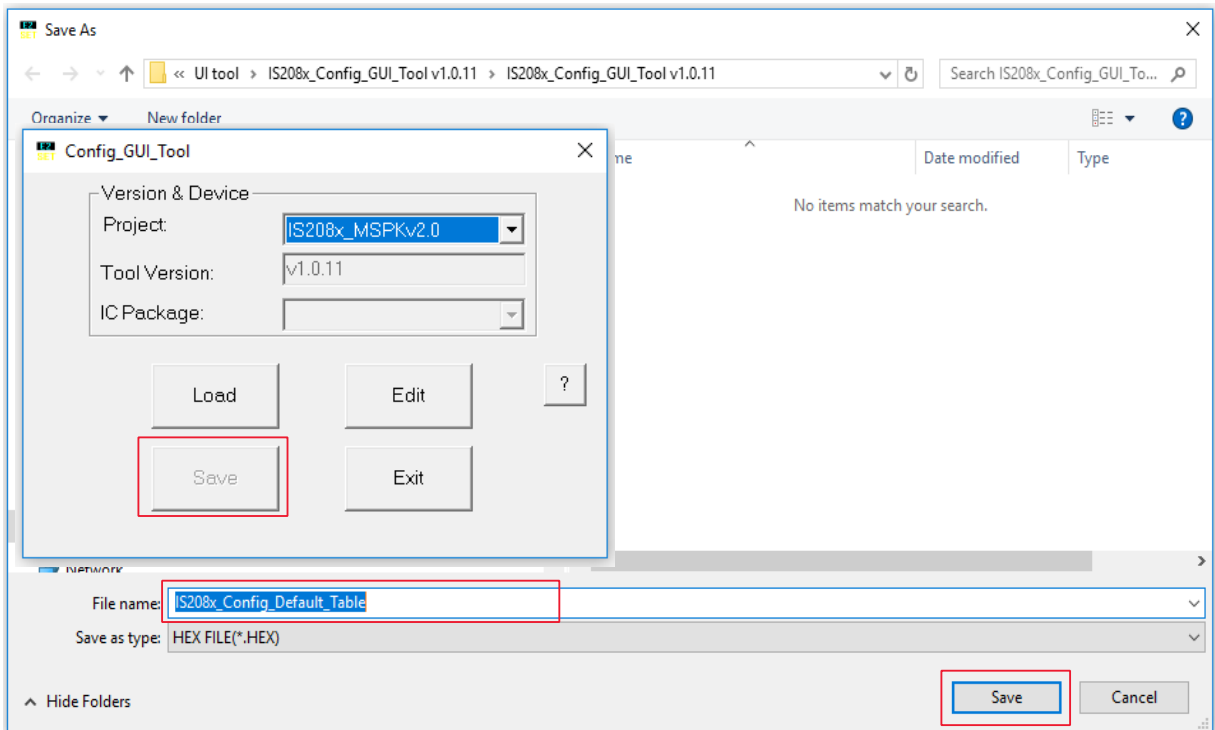

15. Click **Exit** followed by **No**, as shown in the following figure.

**Figure 6-15. Exiting the GUI Tool**

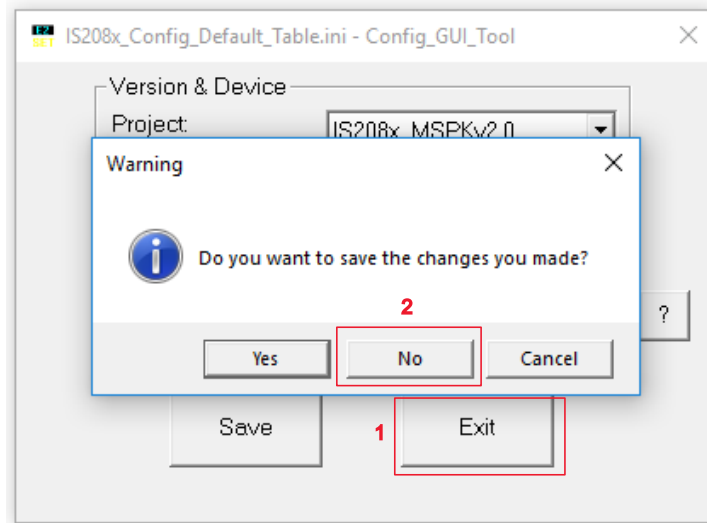

After saving the file, there is an additional `.hex` file in the GUI tool folder, as shown in the following figure.

**Figure 6-16. Generated HEX File**

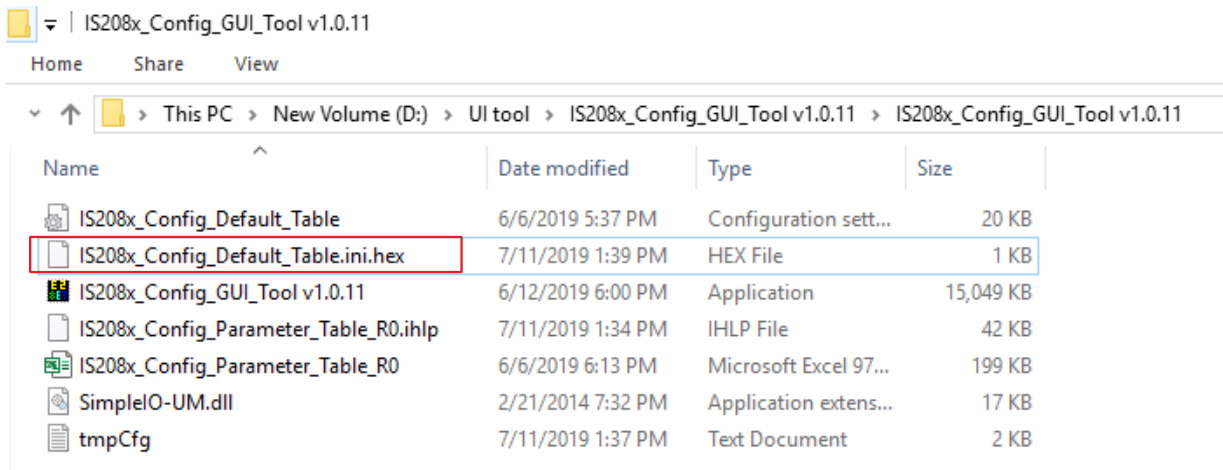

**Note:** For Embedded mode with internal codec demo, refer to [Section 14. Appendix H: Bluetooth Audio Demonstration in Embedded Mode with Internal Codec](#).



## 7. Appendix A: BM83 EVB Reference Schematics

Figure 7-1. USB Connector

### USB CONNECTOR

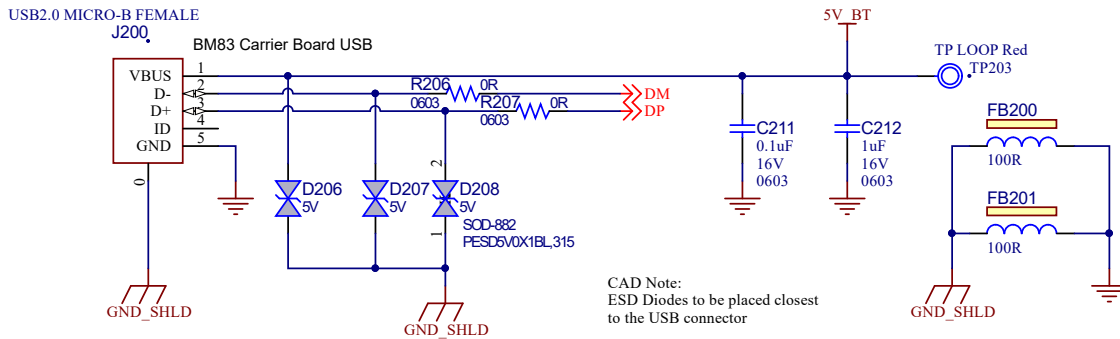

Figure 7-2. BM83 Module Interface (over BM83 Carrier Board)

### MODULE INTERFACE

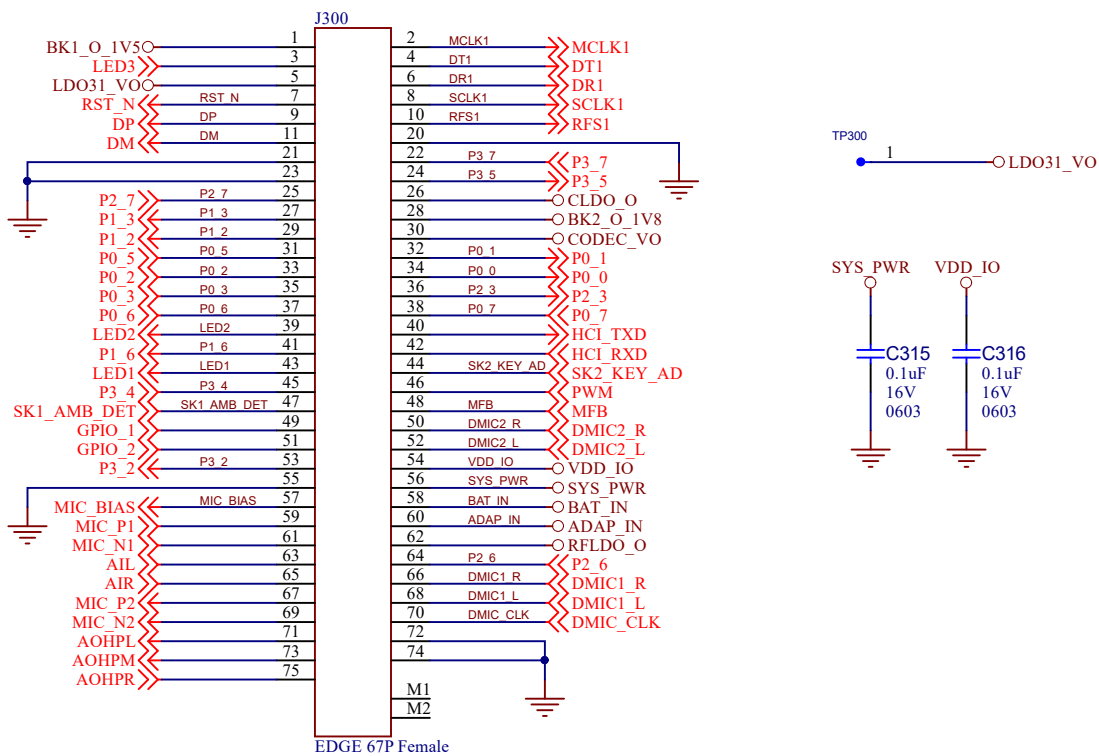

Figure 7-3. 5V Power Switch

5V POWER SWITCH

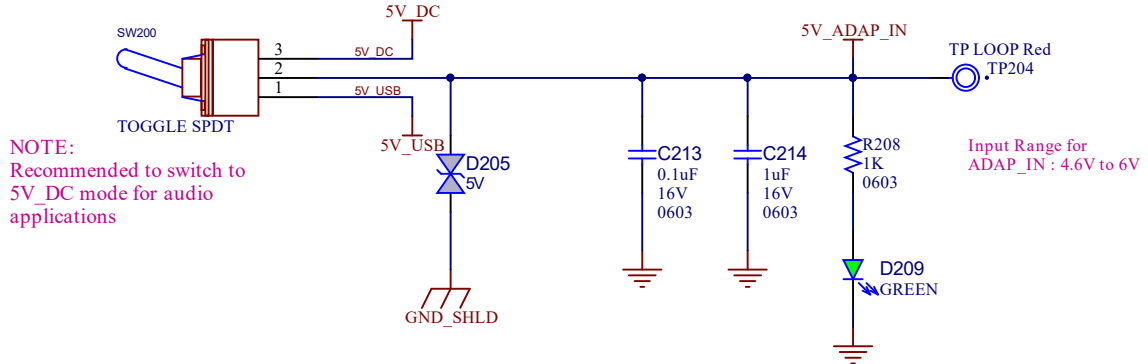

Figure 7-4. USB-UART Converter

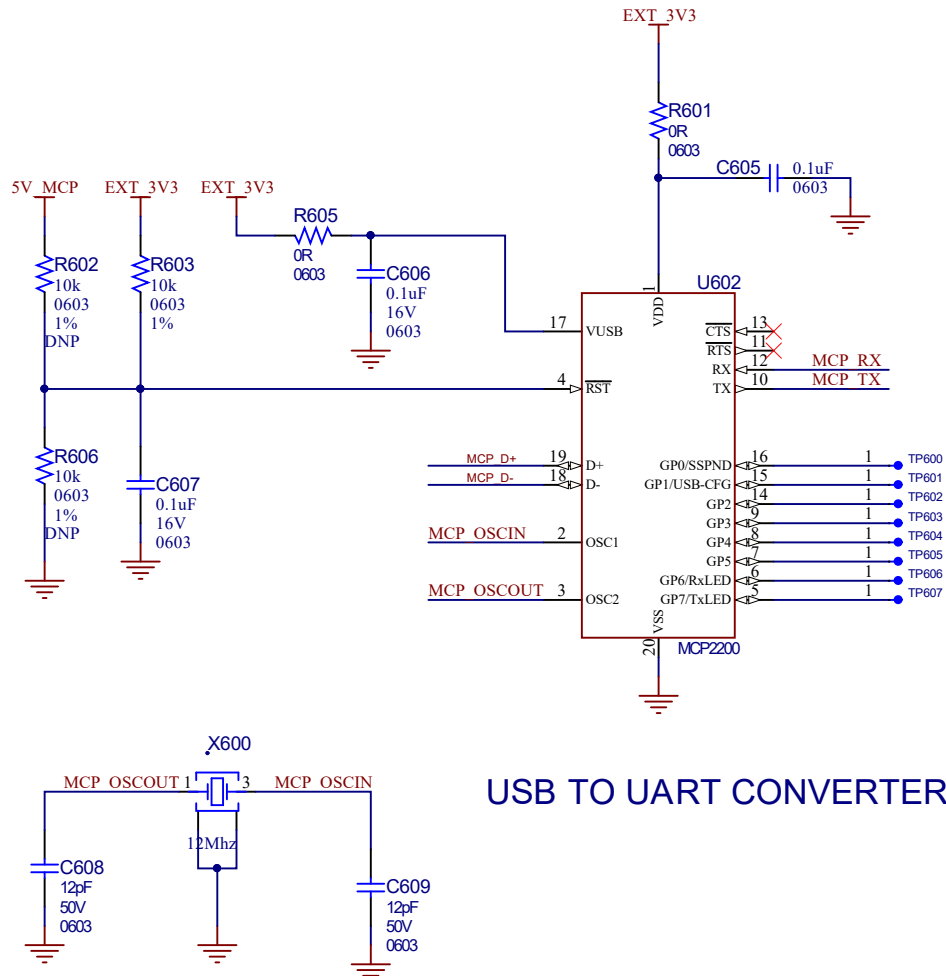

Figure 7-5. Reset IC

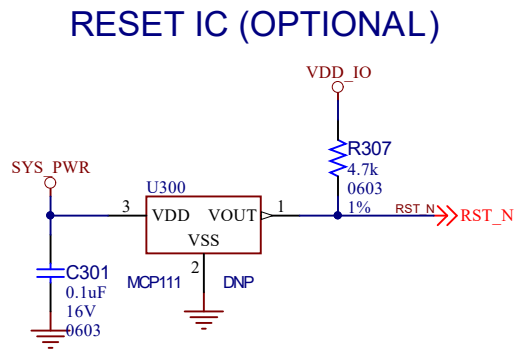

Figure 7-6. Reset

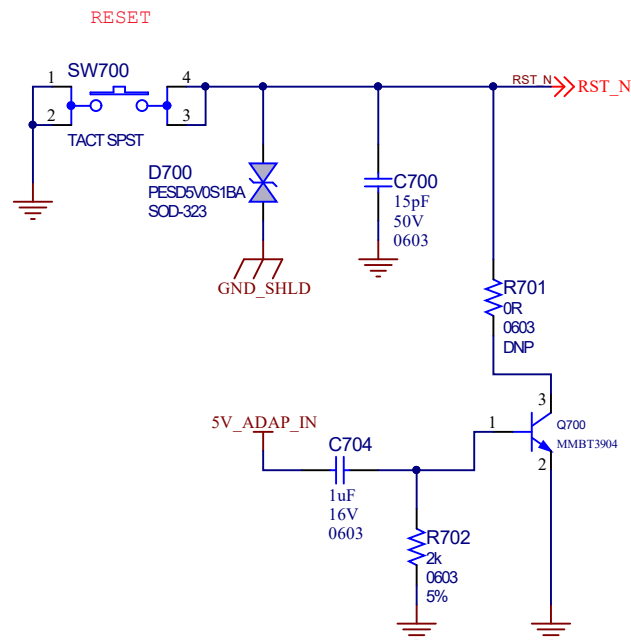

Figure 7-7. Push Button Interface

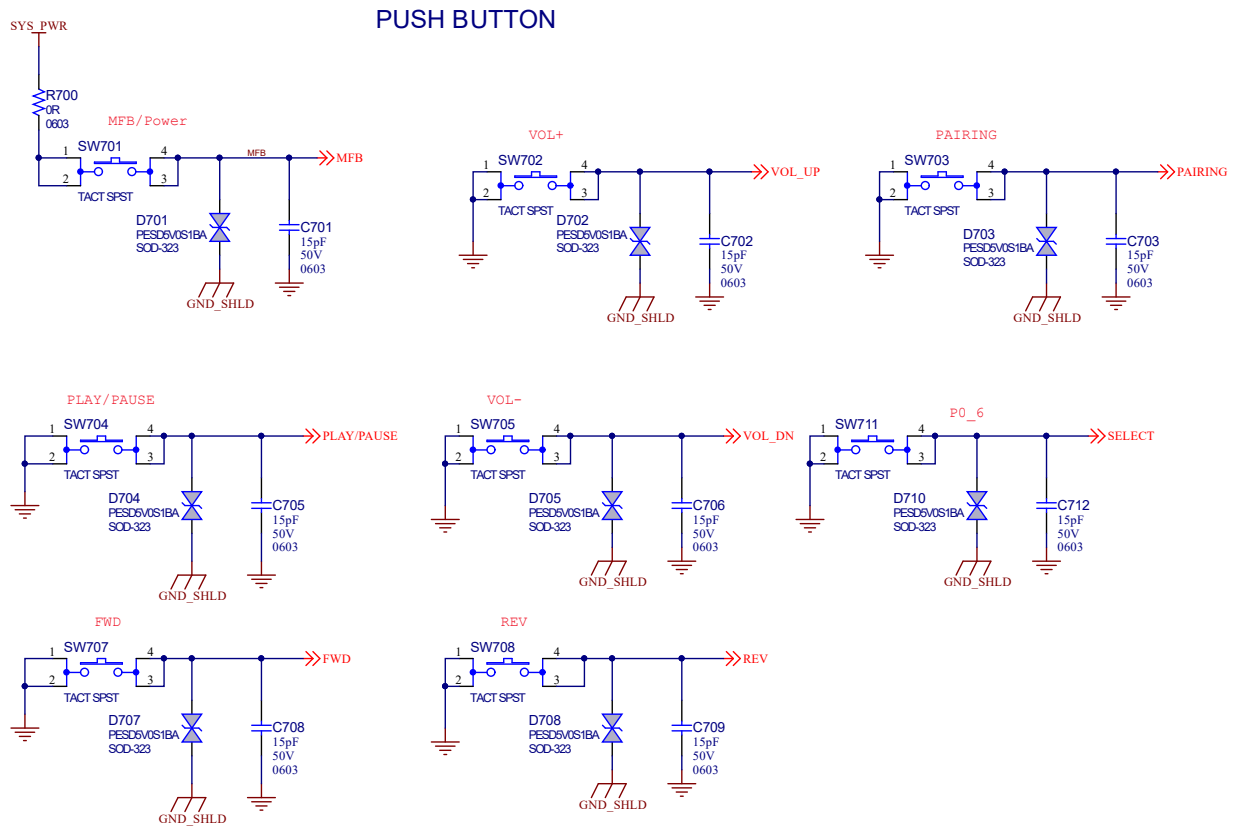

Figure 7-8. PIM Socket

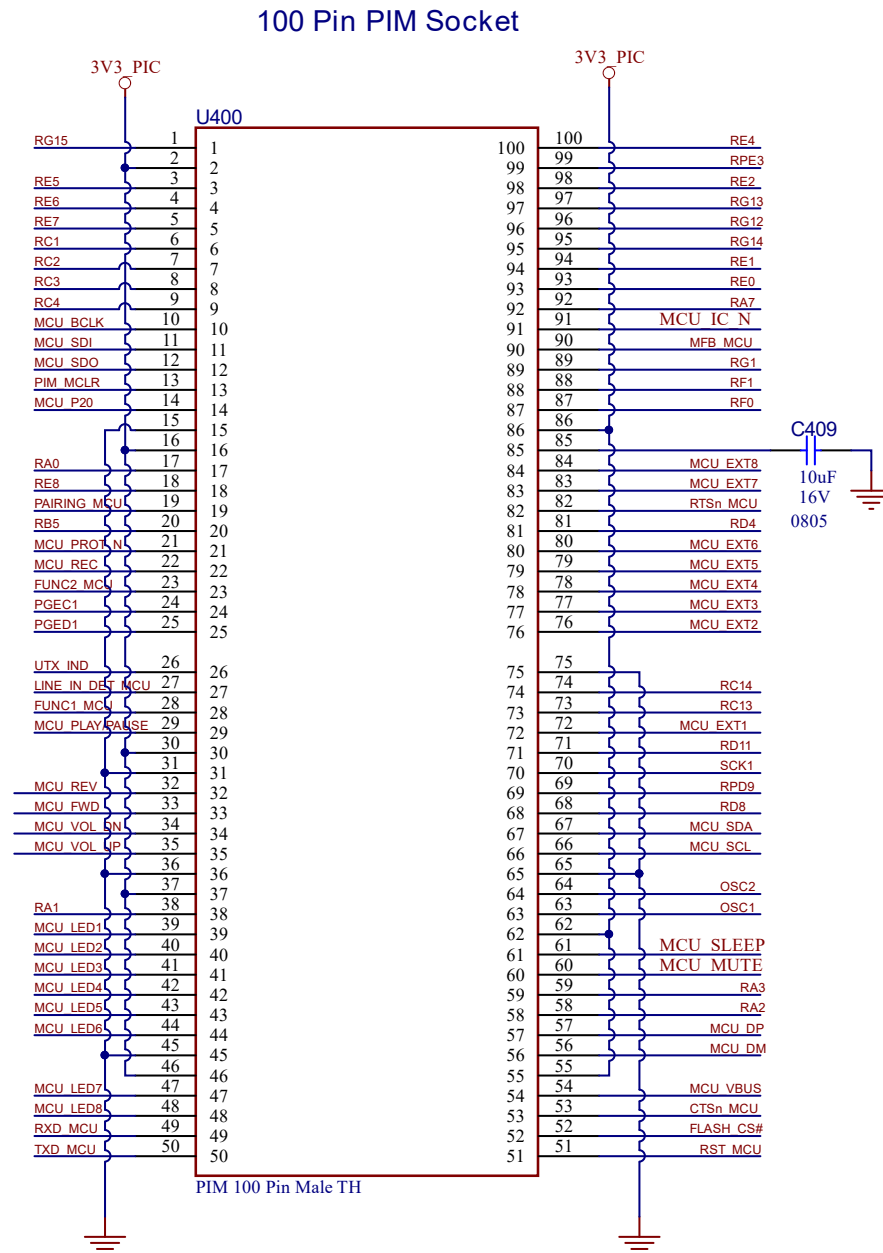
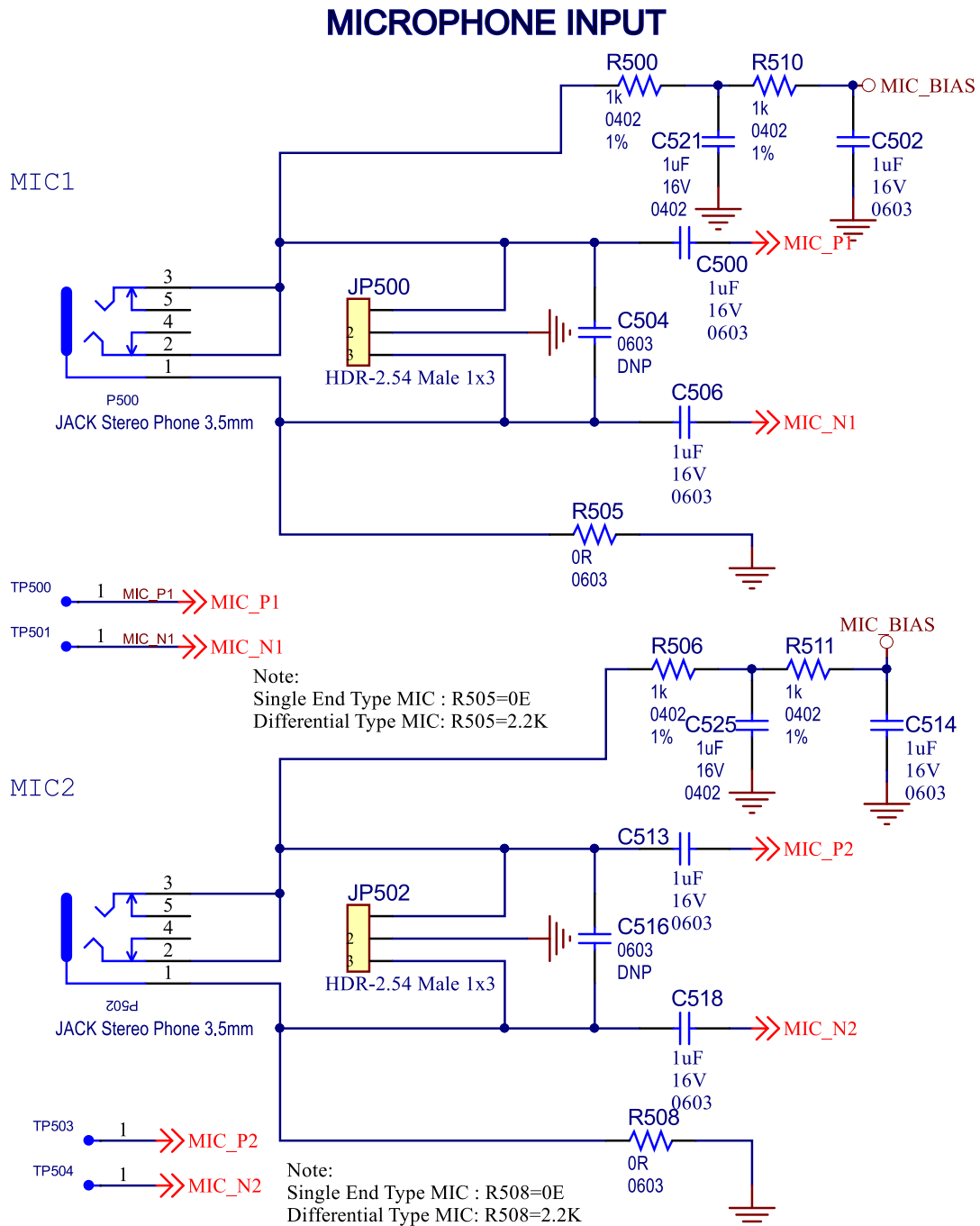

Figure 7-9. Microphone Input



**Note:** While working with the BM83 EVB in a Synchronous Connection Oriented Link (SCO) call scenario, the user may experience some noise on the analog microphone path for microphone gain higher than 35.8 dB. It is recommended to use 35.8 dB analog microphone gain as a starting point for tuning AEC/AES, and users will have to adjust this gain to obtain clear voice without saturation for certain industrial designs. It is also recommended to follow the PCB design guidelines provided by Microchip, for the end-product host board design.

Figure 7-10. MCU to Bluetooth Switch

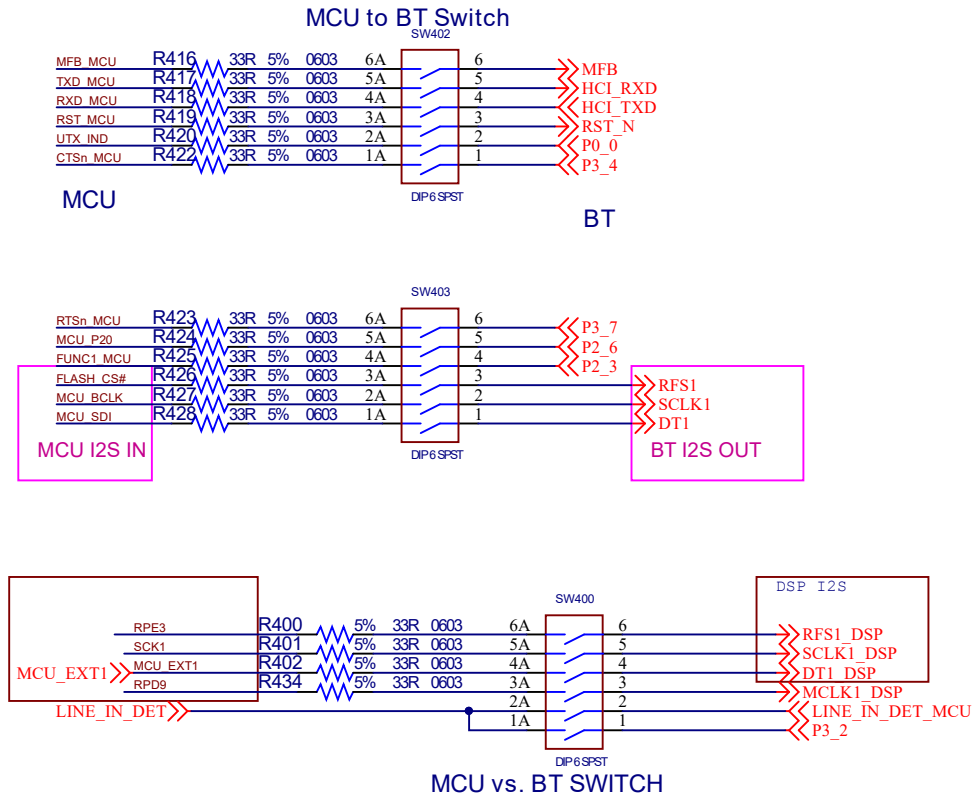

Figure 7-11. PIC32MX450F256L Pin Configuration

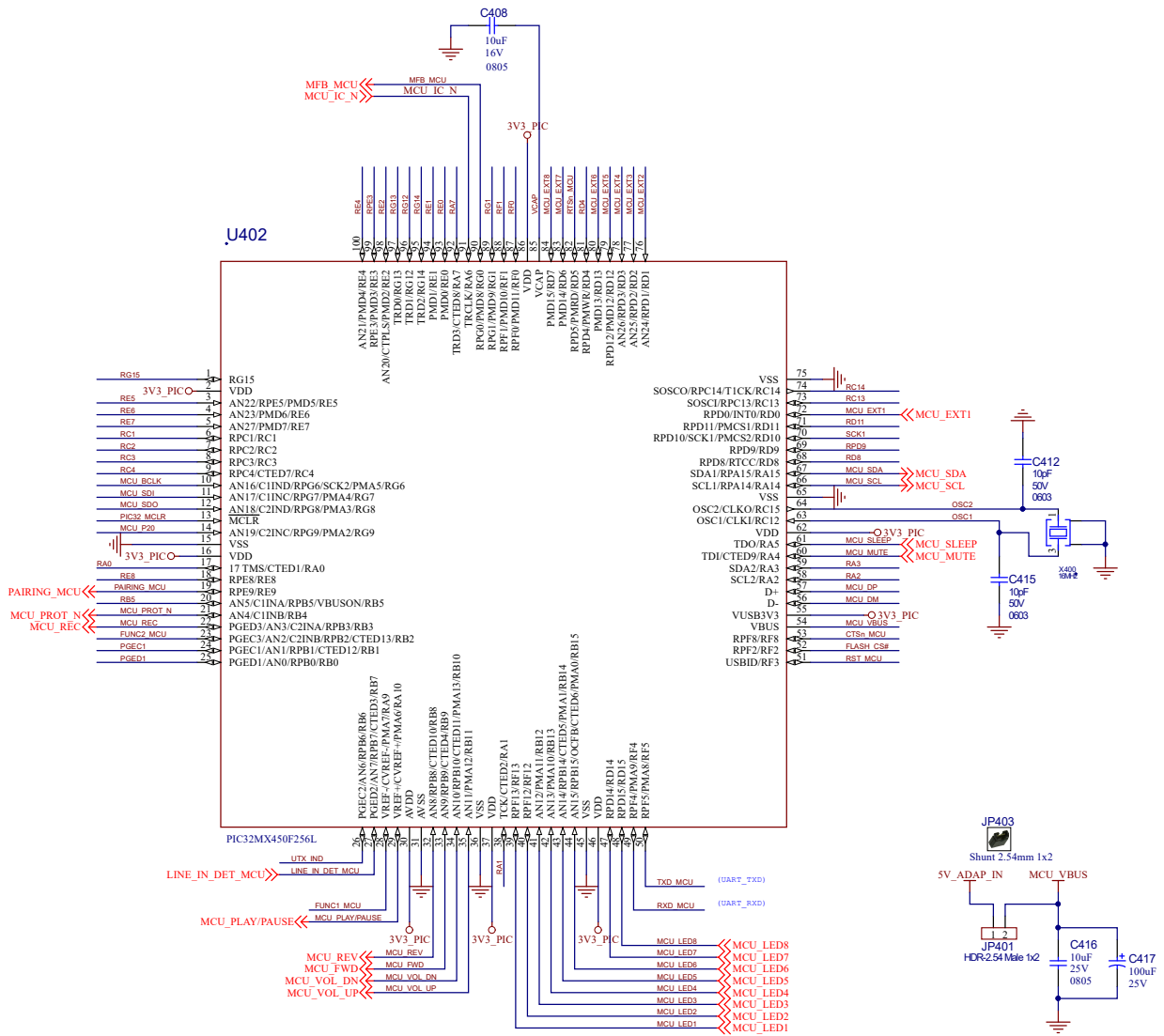



Figure 7-12. LED Interface

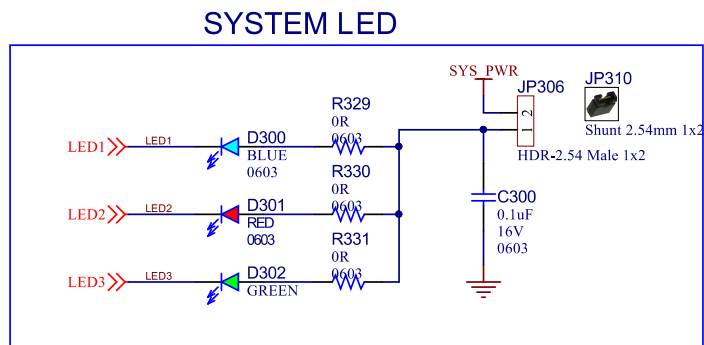
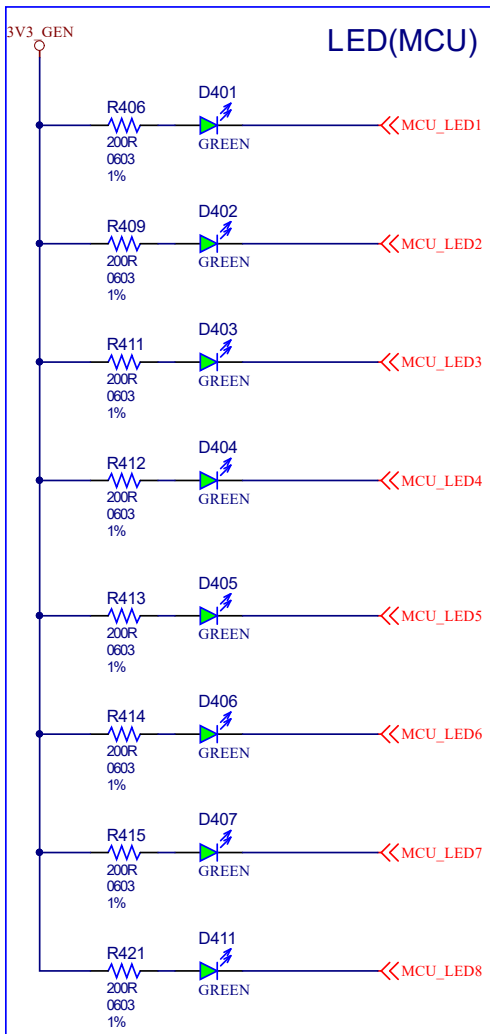
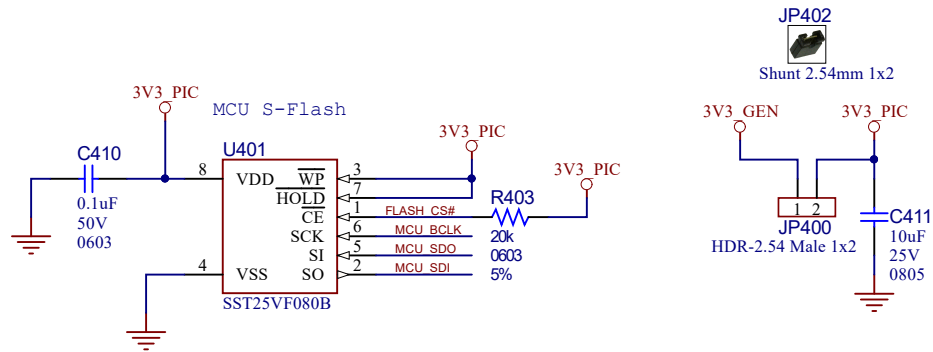

Figure 7-13. ICSP Interface



TARGET SELECT On board MCU or PIM

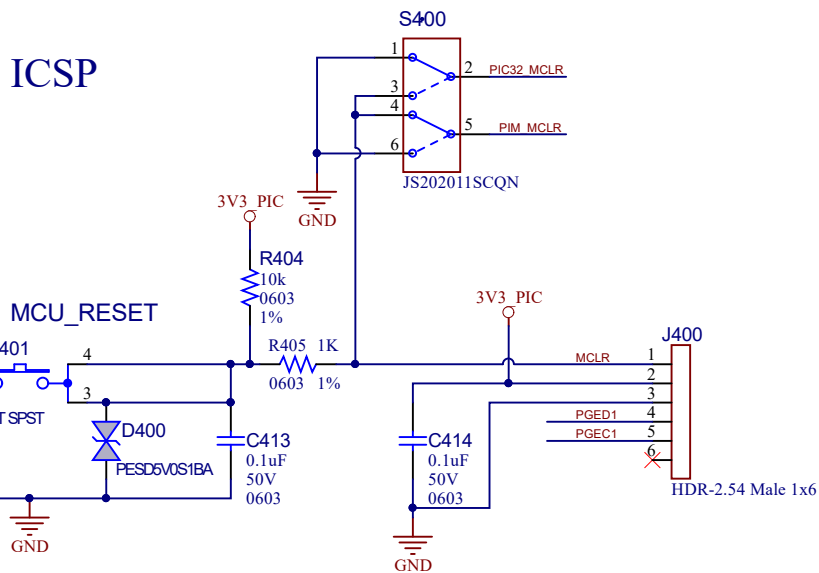

Figure 7-14. I2S Header

### I2S HEADER

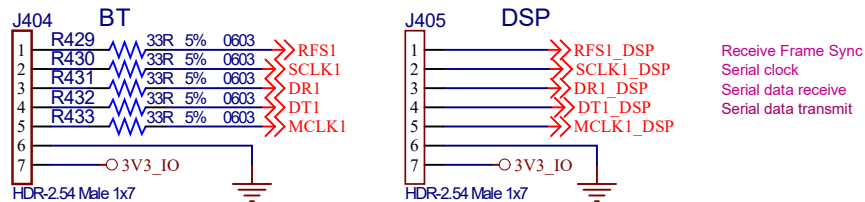

Figure 7-15. I2C Interface

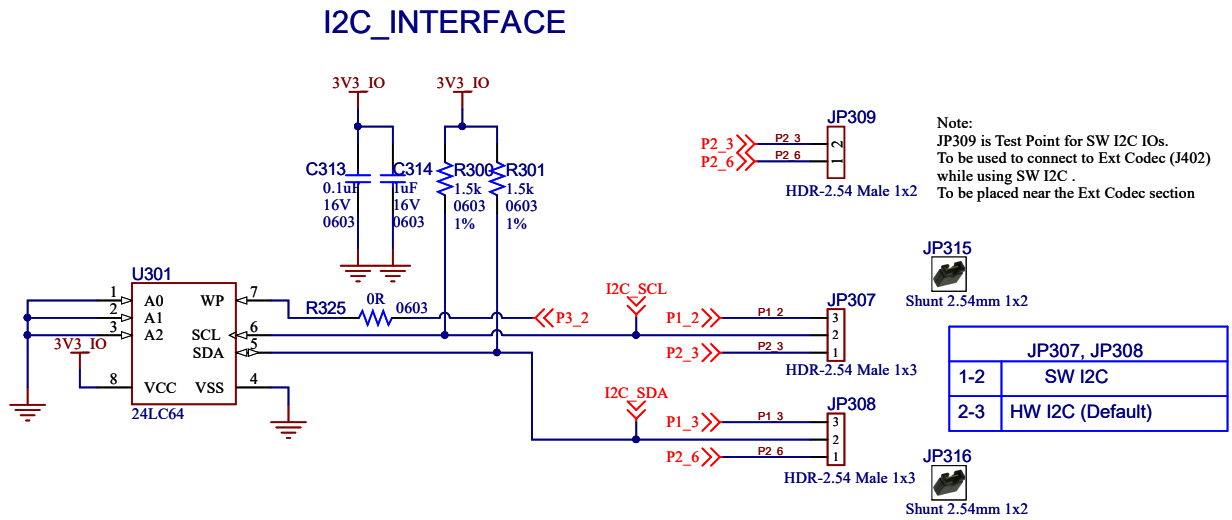

Figure 7-16. BT –DSP–MCU Interface

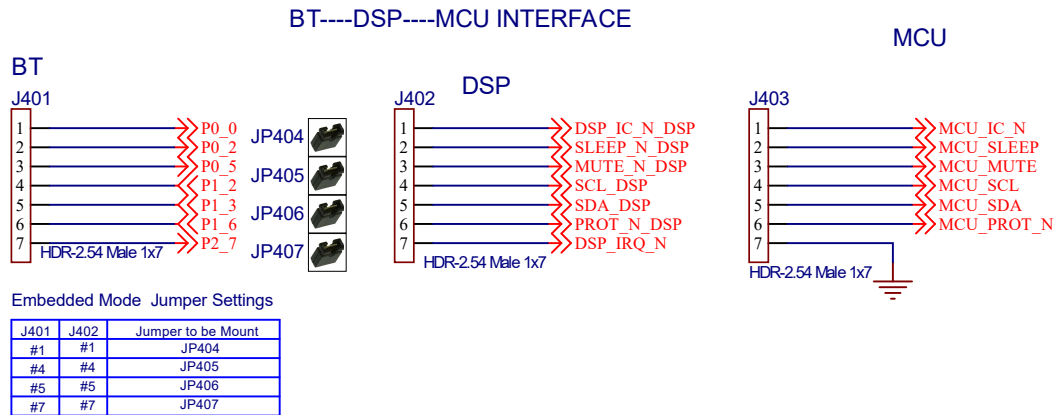

Figure 7-17. Digital MIC and Interface

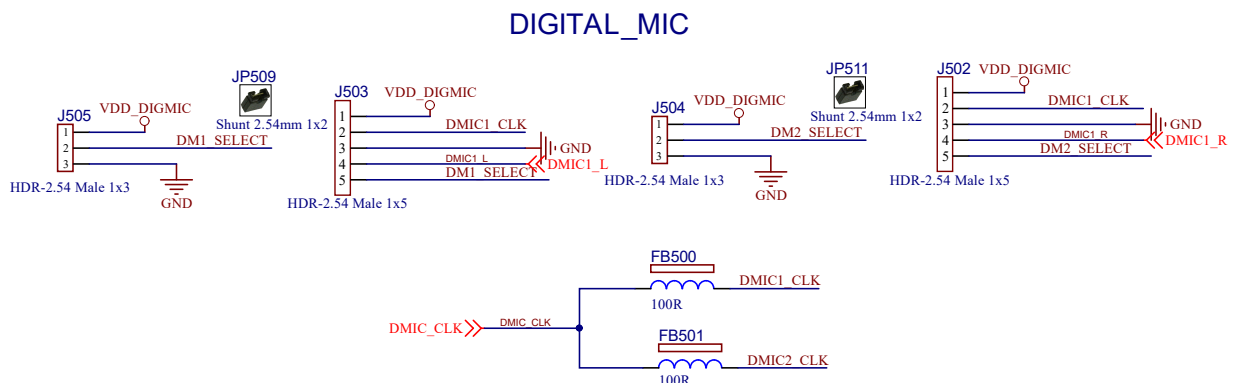

Figure 7-18. CPU JTAG Header

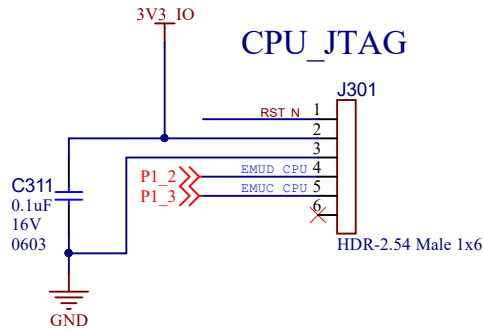

Figure 7-19. XPRO Header

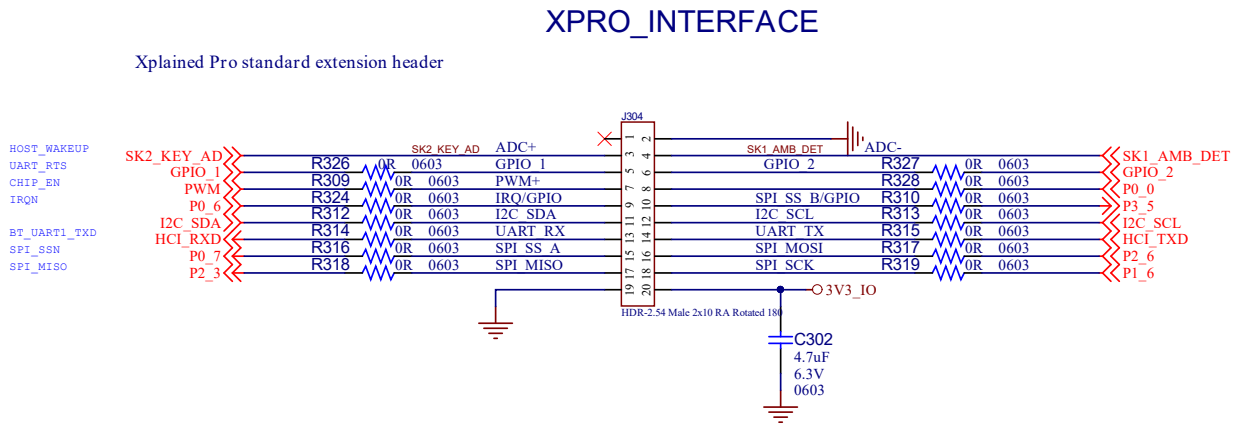

Figure 7-20. Button Control Jumper

### BUTTON CO-USE JUMPER



J701<-->J702 Default Configuration  
 J701<-->J700 For MCU Button Control

CAD Note:  
 Place these 3 headers close to each other

Figure 7-21. Stereo AUX Line Input, Audio Headset Output, Audio Board Interface

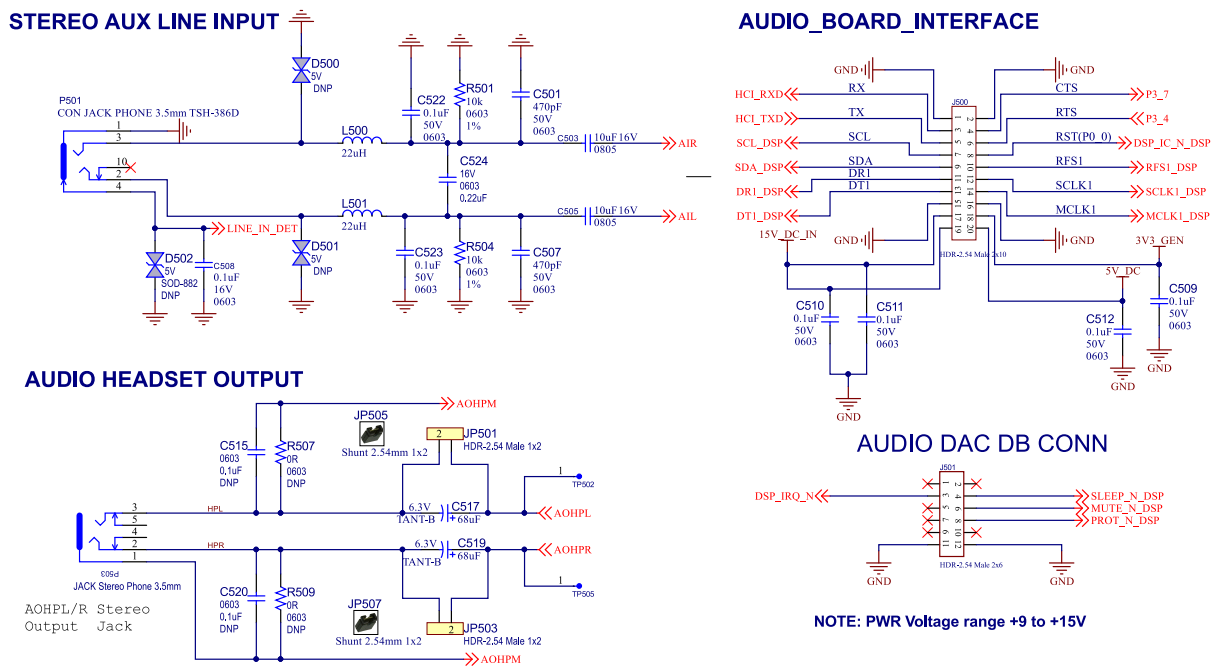

Figure 7-22. Temperature Sensor

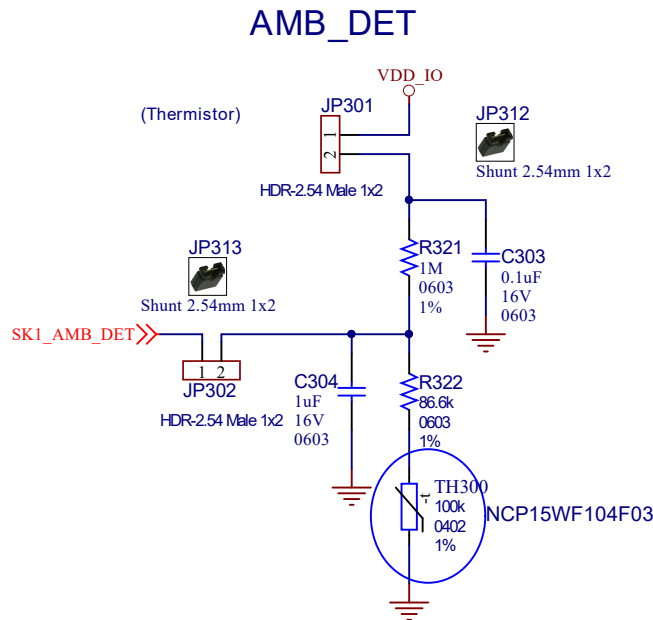
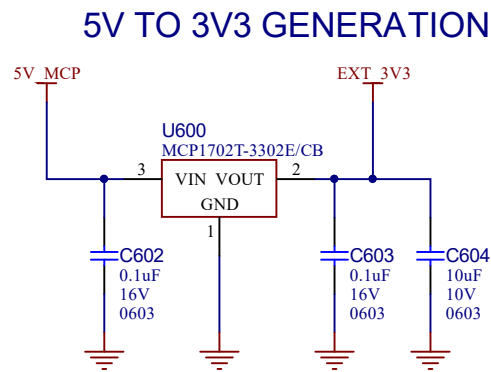

Figure 7-23. 5V to 3V3 Generation for USB-UART Section



## 8. Appendix B: STA369BW Audio Daughter Board

The STA369BW Audio Daughter Board is a high-performance stereo codec board, which is suitable for adding audio input and output capabilities to the Bluetooth Audio development platforms.

The STA369BW Audio Daughter Board has the following components:

- STMicroelectronics codec (STA369BW)
- Female 20-pin dual-row header (J1)
- Female 12-pin dual-row header (J2)
- Audio out connectors (CN1 and CN2)

Figure 8-1. STA369BW Audio Daughter Board

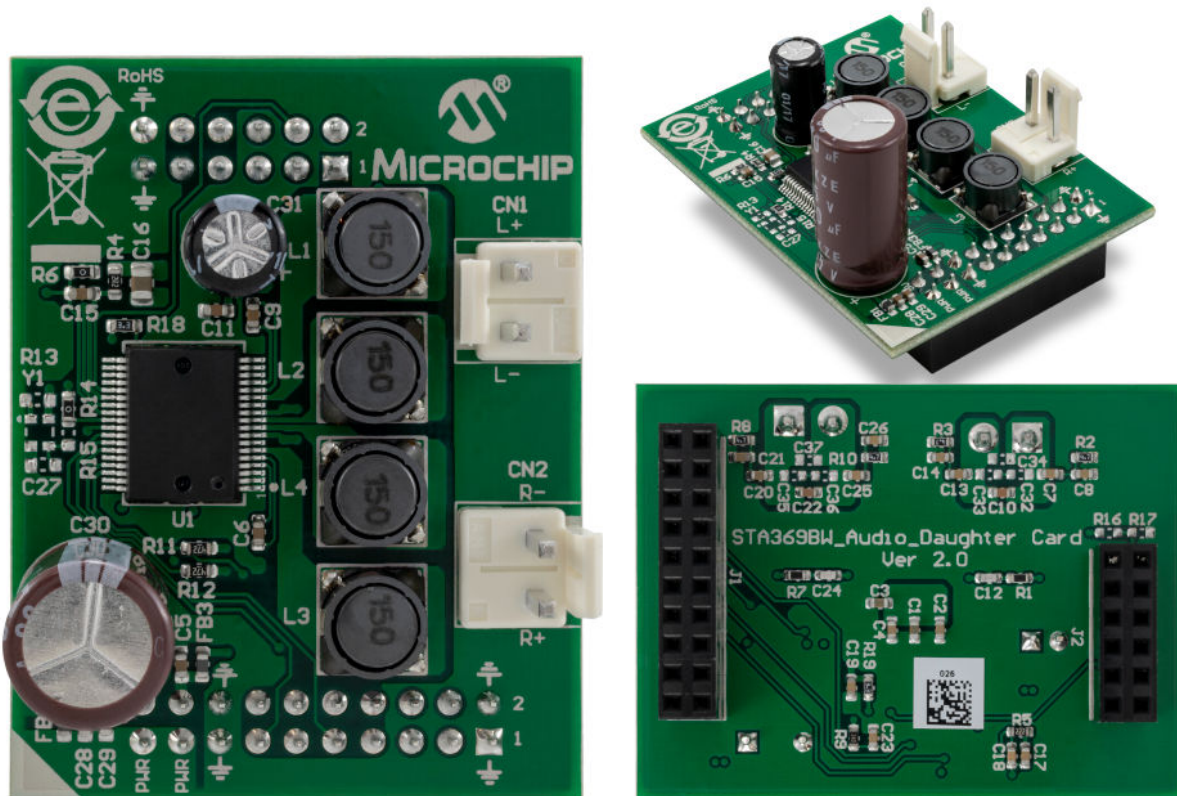

The following table provides the pin description of the Audio Daughter Board headers.

Table 8-1. 20-Pin Audio Daughter Board Header (J1) Pin Details

Pin Name	Pin Number		Pin Name
GND	1	2	GND
UART_RXD	3	4	UART_CTS
UART_TXD	5	6	UART_RTS
I2C_SCL	7	8	RST
I2C_SDA	9	10	I2S_RFS1
I2S_DR1	11	12	I2S_SCLK1
I2S_DT1	13	14	I2S_MCLK1

.....continued

Pin Name	Pin Number		Pin Name
GND	15	16	GND
PWR	17	18	3V3
PWR	19	20	5V

**Table 8-2. 12-Pin Audio Daughter Board Header (J2) Pin Details**

Pin Name	Pin Number		Pin Name
NC	1	2	3V3
DSP_IRQ_N	3	4	PWRDN
NC	5	6	MUTE_N
NC	7	8	INT
NC	9	10	NC
GND	11	12	GND



## 9. Appendix C: Digital Microphone Daughter Board

The Digital Microphone Daughter Board has the following components:

- On-board Knowles' Digital Microphone SPH0641LU4H-1
- Female 5-pin 1x5 header (J1) to interface to BM83 EVB (J503 and J502)

Figure 9-1. Digital Microphone Daughter Board - Top and Bottom View

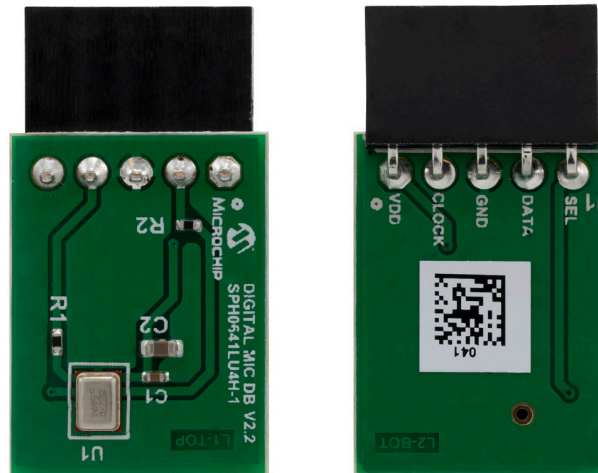

The following table provides the pin description of the Digital Microphone header.

Table 9-1. Digital Microphone Headers (J1, J503 and J502) Pin Description (1, 2, 3, 4)

Pin Number	Digital Microphone Daughter Board	BM83 EVB		Pin Description
	Pin Name (J1)	Pin Name (J503)	Pin Name (J502)	
1	VDD	VDD DIGMIC	VDD DIGMIC	Power supply from the BM83 EVB
2	CLOCK	DMIC1_CLK	DMIC1_CLK	Clock input to the microphone from the BM83 module
3	GND	GND	GND	Ground
4	DATA	DMIC1_L	DMIC1_R	PDM output from the microphone to the BM83 module
5	SEL	DM1 SELECT	DM2 SELECT	Select the input for the microphone

**Notes:**

1. The BM83 module supports 1 stereo Digital Microphone (left and right) terminated at J503 and J502 headers respectively.
2. The VDD power supply for Digital Microphone operation is provided over the J509 header on the BM83 EVB.
3. The Select pin must not be left floating and must be connected to high or low. This is achieved by the 3-pin headers J505 and J504 on the BM83 EVB.
4. For more details on using the Digital Microphone with the BM83, refer to the *IS208x Config UI Tool User's Guide*.

## 10. Appendix D: J-Link 6-Pin Adapter Board

J-Link 6-Pin Adapter Board is designed to connect to its targets through a 20-pin cable, provided with the J-Link. However, BM83 EVB uses a 6-pin connector supporting 2-wire JTAG.

Figure 10-1. J-Link 6-Pin Adapter Board



The following table provides the pin description of the J-Link 6-Pin Adapter Board.

Table 10-1. J-Link 6-Pin Adapter Board Pin Description

Pin Number	Pin Name on J-Link Adapter Board	Pin Name on BM83 EVB	Pin Description
1	Reset_n	Reset_n	Reset
2	3V3	3V3_IO	Power supply from BM83 EVB
3	GND	GND	Ground
4	TDI	P1_2	CPU-2 Wire Debug Data
5	TCK	P1_3	CPU-2 Wire Debug Clock
6	NC	NC	NC

## 11. Appendix E: Updating PIC32 MCU Parameters

Perform the following steps to load the .Hex file to the MCU:

1. Set the SW200 switch to the 5V\_DC position.
2. Plug the 15V DC power adapter into the P200 jack for supplying power to the host MCU.
3. Connect the MPLAB ICD 3 to the ICSP header J400 and PC.

**Figure 11-1. ICD 3 Interface at the ICSP Header**

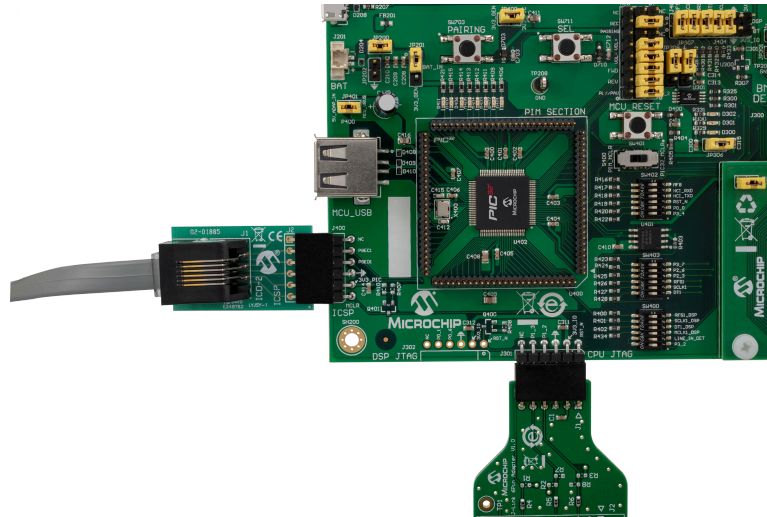

4. Ensure that the jumpers on the JP400 and JP401 are mounted.  
**Note:** Download and install the latest version of the MPLAB X IDE tool, available at [www.microchip.com/mplab/mplab-x-ide](http://www.microchip.com/mplab/mplab-x-ide).
5. Open the MPLAB X IDE tool.
6. Under the Device drop-down menu, select the MCU (PIC32MX450F256L) that is present on the BM83 EVB. The red dot indicates that the selected device does not match.

Figure 11-2. MPLAB X IPE Window

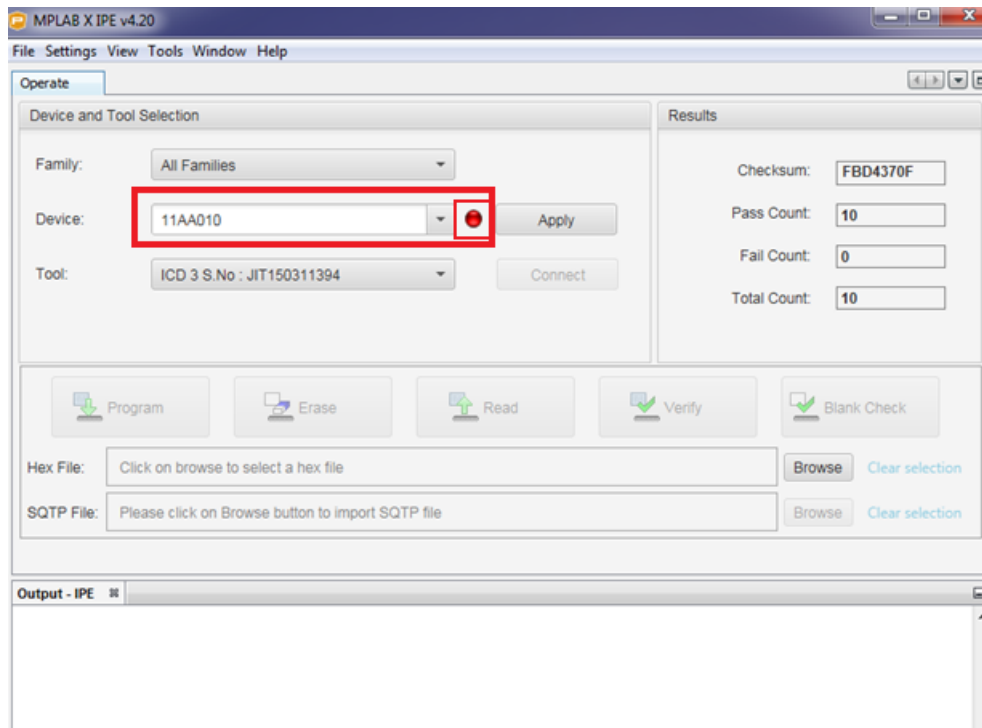

7. Successful device connection is indicated by a green dot. Click **Apply** followed by **Connect**.

Figure 11-3. Search for On-board Microcontroller

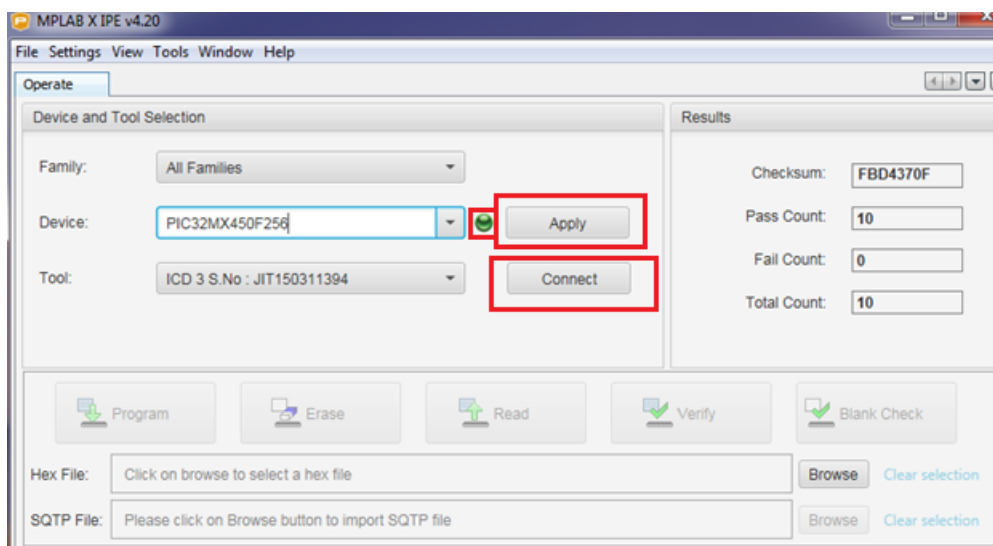

8. After the connection is established, click **Browse** and locate the MCU firmware file from the software folder. Then click **Program**, as shown in the following figure.

Figure 11-4. Connect and Program

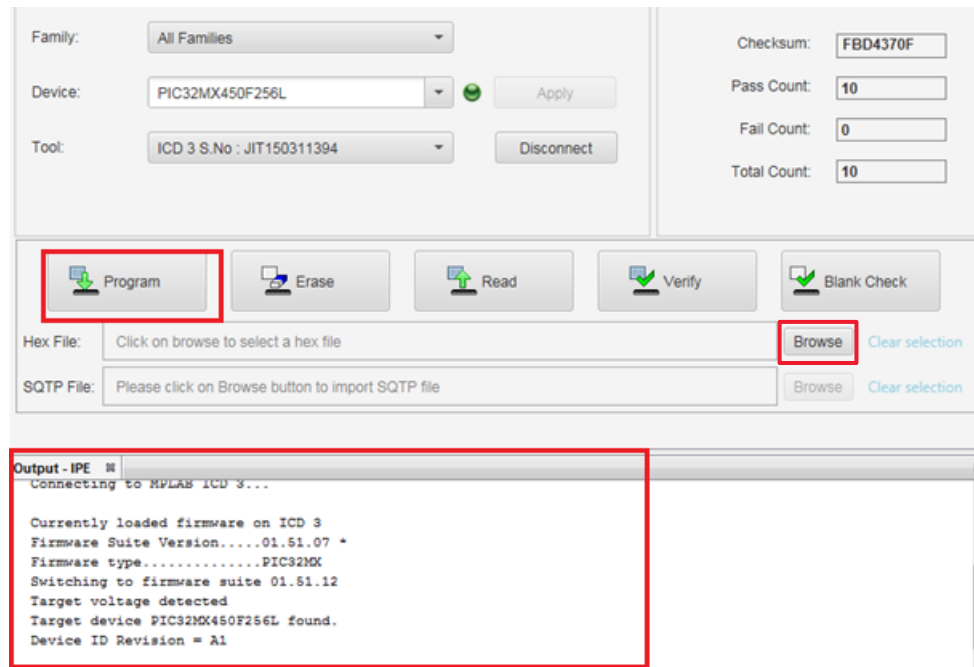

- After the programming is complete, observe the Output – IPE window on the console.  
**Note:** MCU firmware version V1.4.1 is used for the demonstration.

**Figure 11-5. Verify the Log**

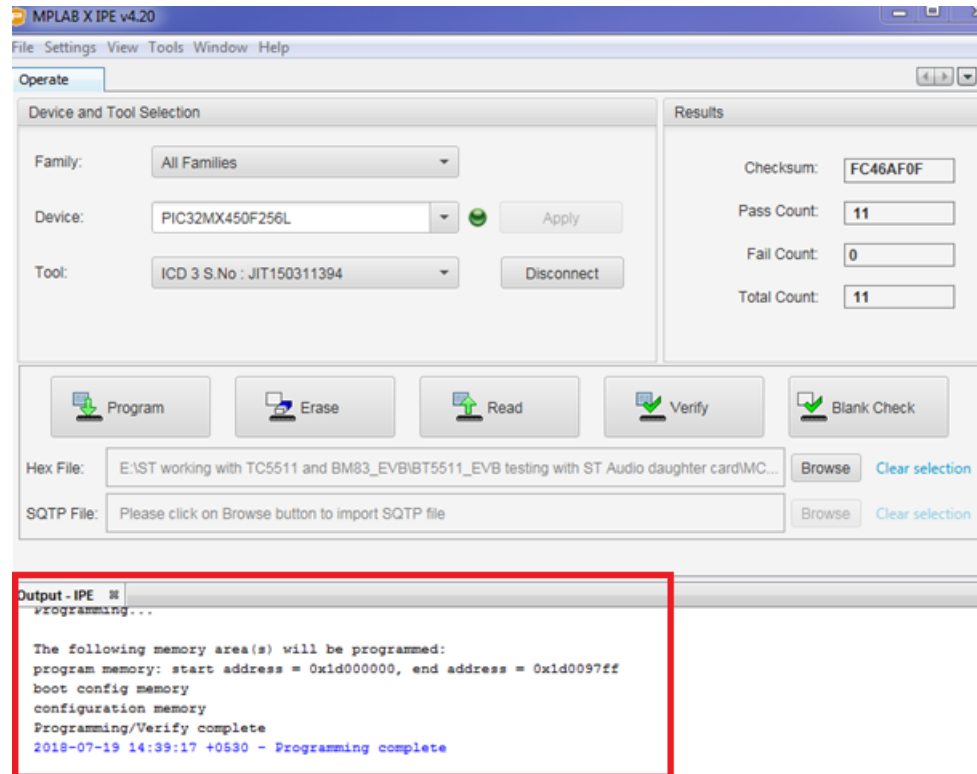

- Remove the 15V adapter.

## 12. Appendix F: Hardware Setup for Application Demo in Host MCU Mode

**Note:** The host MCU (on-board PIC32 MCU) is connected to the BM83 module over UART. The host MCU is controlling the BM83 module and driving the I2S audio out from the BM83 to an STA369BW Audio Daughter Board.

Perform the following hardware changes for the Host MCU mode application demo:

**Note:** To locate these switches, jumpers and headers on the BM83 EVB, refer to [Figure 2-1](#) and [Figure 3-2](#).

1. Mount a jumper on pin2 (3V3\_IO) and pin3 (VDDIO) of the JP305.
2. Set the SW200 switch to the 5V\_DC position to enable the 5V supply to the ADAP\_IN.
3. Mount a jumper on the 3V3\_GEN pin and 3V3\_PIC pin of the JP400 to enable 3.3V to the PIC.
4. The jumper settings on the J402 and J403 to enable the BM83 module to control the DSP (audio codec):
  - 4.1. Mount a jumper on pin1 of the J402 and J403.
  - 4.2. Mount a jumper on pin2 of the J402 and J403.
  - 4.3. Mount a jumper on pin3 of the J402 and J403.
  - 4.4. Mount a jumper on pin4 of the J402 and J403.
  - 4.5. Mount a jumper on pin5 of the J402 and J403.
  - 4.6. Mount a jumper on pin6 of the J402 and J403.
  - 4.7. Open pin7 of the J402 and J403.
5. The jumper settings on the J700 and J701 to enable the BM83 module to control the audio control buttons:
  - 5.1. Mount a jumper on pin1 of the J700 and J701.
  - 5.2. Mount a jumper on pin2 of the J700 and J701.
  - 5.3. Mount a jumper on pin3 of the J700 and J701.
  - 5.4. Mount a jumper on pin4 of the J700 and J701.
  - 5.5. Mount a jumper on pin5 of the J700 and J701.
  - 5.6. Mount a jumper on pin6 of the J700 and J701.
  - 5.7. Mount a jumper on pin6 of the J700 and J701.
  - 5.8. Open pin8 of the J700 and J701.
6. Mount a jumper on pin2 and pin3 of the JP201.
7. Set the SW400 switches as follows:
  - 7.1. RFS1\_DSP to the OFF position.
  - 7.2. SCLK1 to the OFF position.
  - 7.3. DT1\_DSP to the OFF position.
  - 7.4. MCLK1\_DSP to the OFF position.
  - 7.5. LINE\_IN\_DET to the ON position.
  - 7.6. P3\_2 to the OFF position.
8. Set the SW402 switches as follows:
  - 8.1. MFB to the OFF position.
  - 8.2. HCI\_RXD to the ON position.
  - 8.3. HCI\_TXD to the ON position.
  - 8.4. RST\_N to the OFF position.
  - 8.5. P0\_0 to the ON position.
  - 8.6. P3\_4 to the ON position.
9. Set the SW403 switches as follows:
  - 9.1. P3\_7 to the ON position.
  - 9.2. P2\_6 to the OFF position.
  - 9.3. P2\_3 to the OFF position.
  - 9.4. RFS1 to the OFF position.
  - 9.5. SCLK1 to the OFF position.
  - 9.6. DT1 to the OFF position.

10. The jumper settings on the J404 and J405 to connect the BM83 module and the STA369BW codec (ST) over the I2S interface:
  - 10.1. Mount a jumper on pin1 of the J404 and J405.
  - 10.2. Mount a jumper on pin2 of the J404 and J405.
  - 10.3. Mount a jumper on pin3 of the J404 and J405.
  - 10.4. Mount a jumper on pin4 of the J404 and J405.
  - 10.5. Mount a jumper on pin5 of the J404 and J405.
  - 10.6. Open pin6 of the J404 and J405.
  - 10.7. Open pin7 of the J404 and J405.
11. Put the S400 switch to the PIC32\_MCLR position.
12. Put the SW300 switch to the OFF position.

**Note:** In order to perform the following demo, the user must flash the host mode firmware into the BM83 module as well as the PIC32 MCU, as illustrated in the preceding sections.

### 12.1 Host MCU Mode Quick Demo

Perform the following steps to stream audio using the BM83 module in Host MCU mode.

1. Connect the speakers to the STA369BW Audio Daughter Board at CN1 and CN2.

**Figure 12-1. Speakers Connected to the STA369BW Audio Daughter Board**

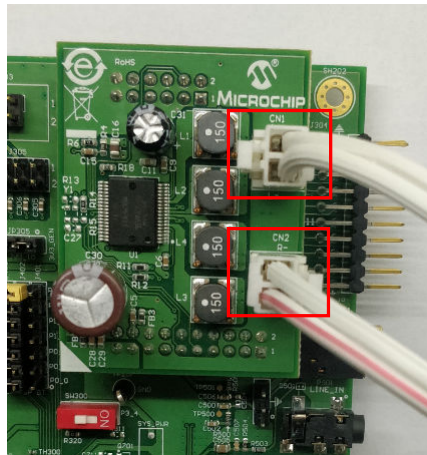

2. The SW200 switch is set to the 5V\_USB position, as shown in the following figure.

**Figure 12-2. SW200 Switch Position**





3. Connect the 15V DC adapter at the DC power jack P200. Notice that the Green LED (D203) and Red LED (D202) turn ON, as shown in the following figure.

**Figure 12-3. 15V DC Adapter Plugged In**

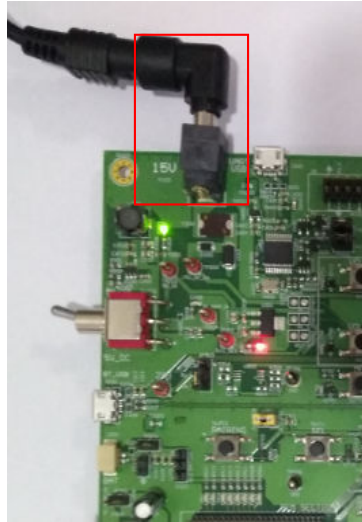

4. Change the SW200 switch to the 5V\_DC position. Notice that the Green LEDs (D209 and D405) turn ON, as shown in the following figure.

**Figure 12-4. LED Indication as SW200 is Turned to 5V\_DC position**

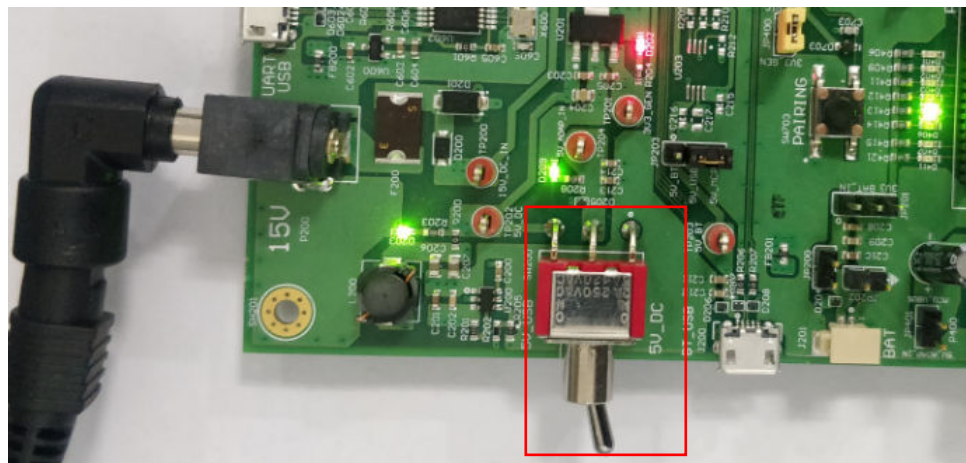

5. Long press the **SEL** button (SW711) to turn on the system. Observe the sound on the speakers and the following LED behavior:
  - Green LED (D401) turns ON
  - Blue (D300) and Green (D402) LEDs blink
6. Long press the **SEL** button (SW711) to make the BM83 module discoverable to other devices. Observe the sound on the speakers and the alternate blinking of the Red LED (D301) and Blue LED (D300).
7. Follow the steps to pair the BM83 module with a smartphone:
  - 7.1. Turn on the smartphone's Bluetooth to scan for the available devices.
  - 7.2. Select the module device name "BM83" from the scan results. Pair and connect the device.
  - 7.3. On successful pairing, the device name displays as **Connected**.

**Note:** This demonstration uses the EA1 demo version of the firmware.

**Figure 12-5. Pairing and Connection**

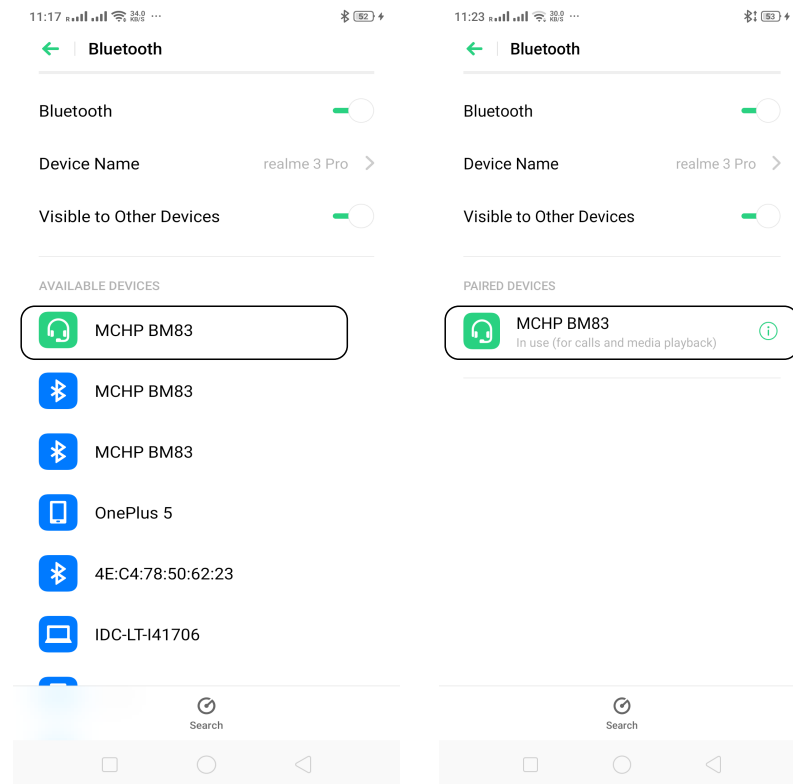

- 7.4. Stream the audio from the smartphone to the BM83 over the Bluetooth connection and listen to it through the speakers.
8. Control the audio with the following buttons:
  - 8.1. Press the **VOL\_UP** button (SW702) to increase the volume.
  - 8.2. Press the **VOL\_DN** button (SW705) to reduce the volume.
  - 8.3. Press the **Pause** button (SW704) to pause the audio.
  - 8.4. Press the **Play** button (SW704) to play the audio.
  - 8.5. Press the **FWD** button (SW707) to jump to the next audio file.
  - 8.6. Press the **REV** button (SW708) to jump to the previous audio file.
  - 8.7. Press the **SEL** button (SW711) to turn OFF the system.

## 13. Appendix G: Hardware Setup for Application Demo in Embedded Mode

**Note:** In this mode of operation, the BM83 module is driving the I2S audio out to the STA369BW Audio Daughter Board. The BM83 module is connected to the external codec over I2S and I2C.

Perform the following hardware changes for the Embedded mode application demo.

**Note:** To locate these switches, jumpers and headers on the BM83 EVB, refer to [Figure 2-1](#) and [Figure 3-2](#).

1. Mount a jumper on the 3V3\_IO pin and VDDIO pins of the JP305 pin 2 and pin3.
2. Put the SW200 switch to the 5V\_DC position to enable the 5V supply to the ADAP\_IN.
3. The jumper settings on the J401 and J402 enable the BM83 module to control the STA369BW Audio Daughter Board:
  - 3.1. Mount a jumper on pin1 of the J401 and J402.
  - 3.2. Open pin2 of the J401 and J402.
  - 3.3. Open pin3 of the J401 and J402.
  - 3.4. Mount a jumper on pin4 of the J401 and J402.
  - 3.5. Mount a jumper on pin5 of the J401 and J402.
  - 3.6. Open pin6 of the J401 and J402.
  - 3.7. Mount a jumper on pin7 of the J401 and J402.
4. The jumper settings on the J701 and J702 to enable the BM83 module to control the audio control buttons:
  - 4.1. Mount a jumper on pin1 of the J701 and J702.
  - 4.2. Mount a jumper on pin2 of the J701 and J702.
  - 4.3. Mount a jumper on pin3 of the J701 and J702.
  - 4.4. Mount a jumper on pin4 of the J701 and J702.
  - 4.5. Mount a jumper on pin5 of the J701 and J702.
  - 4.6. Open pin6 of the J701 and J702.
  - 4.7. Mount a jumper on pin7 of the J701 and J702.
  - 4.8. Open pin8 of the J701 and J702.
5. Mount a jumper on the JP201 pin2 and pin3.
6. Set the SW400 switches as follows:
  - 6.1. RFS1\_DSP to the OFF position.
  - 6.2. SCLK1 to the OFF position.
  - 6.3. DT1\_DSP to the OFF position.
  - 6.4. MCLK1\_DSP to the OFF position.
  - 6.5. LINE\_IN\_DET to the OFF position.
  - 6.6. P3\_2 to the ON position.
7. Set the SW402 switches as follows:
  - 7.1. MFB to the OFF position.
  - 7.2. HCI\_RXD to the OFF position.
  - 7.3. HCI\_TXD to the OFF position.
  - 7.4. RST\_N to the OFF position.
  - 7.5. P0\_0 to the OFF position.
  - 7.6. P3\_4 to the OFF position.
8. Set the SW403 switches as follows:
  - 8.1. P3\_7 to the OFF position.
  - 8.2. P2\_6 to the OFF position.
  - 8.3. P2\_3 to the OFF position.
  - 8.4. RFS1 to the OFF position.
  - 8.5. SCLK1 to the OFF position.

- 8.6. DT1 to the OFF position.
9. The jumper settings on the J404 and J405 to connect the BM83 module I2S with the STA369BW Audio Daughter Board I2S:
  - 9.1. Mount a jumper on pin1 of the J404 and J405.
  - 9.2. Mount a jumper on pin2 of the J404 and J405.
  - 9.3. Mount a jumper on pin3 of the J404 and J405.
  - 9.4. Mount a jumper on pin4 of the J404 and J405.
  - 9.5. Mount a jumper on pin5 of the J404 and J405.
  - 9.6. Open pin6 of the J404 and J405.
  - 9.7. Open pin7 of the J404 and J405.
10. Put the SW300 switch to the OFF position.
11. By default, the board is configured with hardware (HW) I2C settings. For more details on the software (SW) I2C settings, refer to the *I2C Interface* section in the *IS2083 SDK User's Guide* ([DS50002894](#)).
12. Mount a jumper on pin2 and pin3 of the JP203.

With the above settings, the user can plug in the 15V DC adapter and perform the application demo in Embedded mode with the appropriate firmware image. This firmware image for the Embedded mode is available at [www.microchip.com/BM83](http://www.microchip.com/BM83).

## 14. Appendix H: Bluetooth Audio Demonstration in Embedded Mode with Internal Codec

### Notes:

1. In this mode of operation, the BM83 module uses the internal codec to drive the audio.
2. Do not connect the 15V adapter at the DC power jack P200.
3. Use the internal codec config file for this demo. For more details, refer to [Section 6.1 Config Tool Setup](#).

In this demonstration, the user can stream audio on the BM83 EVB using a smartphone. Perform the following hardware settings on the BM83 EVB for Embedded mode with internal codec audio demo after updating the firmware:

1. Turn OFF the SW300 switch.
2. Mount a jumper at the 5V\_ADAP\_IN and ADAP\_IN of the JP304.
3. Mount the JP501 and JP503 (stereo out). Connect headphones or a speaker at the stereo jack P503.
4. Set the SW200 switch to 5V\_USB.
5. Plug in the USB cable at J600. Observe that the Red LED (D600) and Green LED (D209) turn ON.  
**Note:** The Red LED (D300) and Blue LED (D301) do not glow in this case.
6. Long press the **MFB** button (SW701) to turn ON the system, and keep pressing the **MFB** button to enter into Pairing mode. Once the system is turned ON, the Red LED (D301) and the Blue LED (D300) blink alternately to indicate that the device has entered Pairing mode.
7. The following steps help in pairing between the BM83 module and a smartphone:
  - 7.1. Turn ON the smartphone's Bluetooth to scan for the discoverable devices.
  - 7.2. Select the module device name "BM83" from the scan results.
  - 7.3. Enter 0000 as the passcode to pair the smartphone with the BM83 module. The passcode is not required if simple pairing is enabled in the Config Tool.

The smartphone displays "Connected" upon successful pairing, as shown in the following figure. The audio can be listened to through the headphones.

Figure 14-1. Pairing BM83 with Smartphone

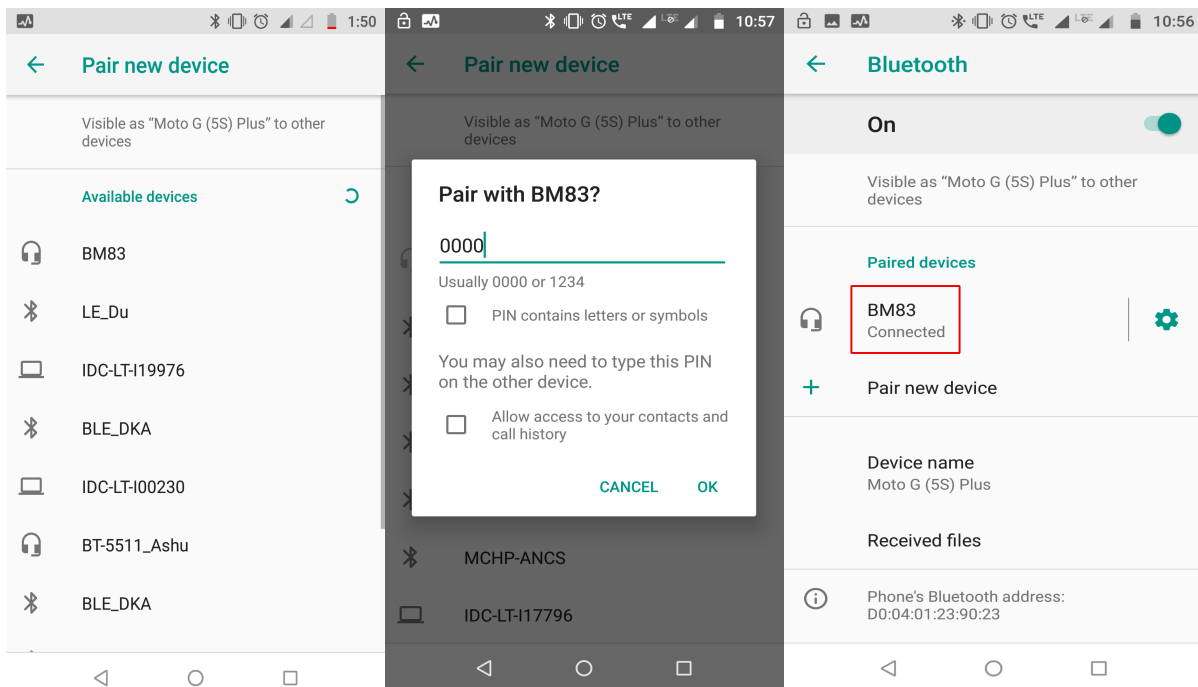

## 15. Regulatory Approvals

This equipment (BM83 EVB/DM164152) is an evaluation kit and not a finished product. It is intended for laboratory evaluation purposes only. Using this requires a significant engineering expertise towards understanding of the tools and relevant technology, which can be expected only from a person who is professionally trained in the technology. Regulatory compliance settings have to follow the module (BM83 Module) certifications.

The following regulatory notices are to cover the requirements under the regulatory approval.

### 15.1 United States

The BM83 EVB (DM164152) contains the BM83 module, which has received the Federal Communications Commission (FCC) CFR47 Telecommunications, Part 15 Subpart C “Intentional Radiators” single-modular approval in accordance with the Part 15.212 Modular Transmitter approval.

Contains Transmitter Module FCC ID: 2ADHKBM83SM1.

**This device complies with Part 15 of the FCC Rules. Operation is subject to the following two conditions: (1) this device may not cause harmful interference, and (2) this device must accept any interference received, including interference that may cause undesired operation.**

#### Important: FCC Radiation Exposure Statement

This equipment complies with FCC radiation exposure limits set forth for uncontrolled environments.

The antenna integrated with this transmitter must be provided a separation distance of at least 20 cm from all persons and must not be colocated or operated in conjunction with any other antenna or transmitter.

This transmitter is restricted for use with the integrated antenna tested in this application for certification.



Any changes or modifications not expressly approved by the party responsible for compliance could void the user's authority to operate this equipment.

#### FCC Notice

This kit is designed to allow:

- Product developers to evaluate electronic components, circuitry, or software associated with the kit to determine whether to incorporate such items in a finished product.
- Software developers to write software applications for use with the end product. This kit is not a finished product and when assembled may not be resold or otherwise marketed unless all required FCC equipment authorizations are first obtained. Operation is subject to the condition that this product not cause harmful interference to licensed radio stations and that this product accept harmful interference. Unless the assembled kit is designed to operate under part 15, part 18 or part 95 of this chapter, the operator of the kit must operate under the authority of an FCC license holder or must secure an experimental authorization under part 5 of this chapter.
- The kit is labeled with the following legend: For evaluation only; not FCC approved for resale; and any radio frequency transmitter employed as part of an evaluation kit shall be designed to comply with all applicable FCC technical rules, including frequency use, spurious and out-of-band emission limits, and maximum power or field strength ratings applicable to final products that would employ the components or circuitry to be evaluated.
- Under [47 CFR 2.805\(d\)\(2\)](#) in order to operate the evaluation kit, the user must ultimately render the device inoperable or return it to Microchip.
- Evaluation kit is defined by FCC as “[a]n assembly of components, subassemblies, or circuitry, including software, created by or for a component maker, system integrator, or product developer for the sole purpose of facilitating: End product developer evaluation of all or some of such components, subassemblies, or circuitry, or (ii) the development of software to be used in an end product.” (see [47 CFR 2.1](#))

## 15.2 Canada

The BM83 EVB (DM164152) contains the BM83 module, which has been certified for use in Canada under the Innovation, Science and Economic Development (ISED, formerly Industry Canada) Radio Standards Procedure (RSP) RSP-100, Radio Standards Specification (RSS) RSS-Gen and RSS-247.

Contains IC: 20266-BM83SM1.

This device contains license-exempt transmitter(s)/receiver(s) that comply with Innovation, Science and Economic Development Canada's license-exempt RSS(s). Operation is subject to the following two conditions:

1. This device may not cause interference;
2. This device must accept any interference, including interference that may cause undesired operation of the device.

L'émetteur/récepteur exempt de licence contenu dans le présent appareil est conforme aux CNR d'Innovation, Sciences et Développement économique Canada applicables aux appareils radio exempts de licence. L'exploitation est autorisée aux deux conditions suivantes:

1. L'appareil ne doit pas produire de brouillage;
2. L'appareil doit accepter tout brouillage radioélectrique subi, même si le brouillage est susceptible d'en compromettre le fonctionnement.



This equipment complies with radio frequency exposure limits set forth by Innovation, Science and Economic Development Canada for an uncontrolled environment. This equipment should be installed and operated with a minimum distance of 20 cm between the device and the user or bystanders.

Cet équipement est conforme aux limites d'exposition aux radiofréquences définies par d'Innovation, Sciences et Développement économique Canada pour un environnement non contrôlé. Cet équipement doit être installé et utilisé avec un minimum de 20cm de distance entre le dispositif et l'utilisateur ou des tiers.

## 15.3 Europe

This equipment (DM164152) has been assessed under the Radio Equipment Directive (RED) standard for radio equipment and services for use in European Union countries. The product does not exceed the specified power ratings, antenna specifications and/or installation requirements, as specified in the user manual. A Declaration of Conformity is issued for each of these standards and kept on file as described in the Radio Equipment Directive (RED).

### **Simplified EU Declaration of Conformity**

Hereby, Microchip Technology Inc. declares that the radio equipment type [DM164152] is in compliance with Directive 2014/53/EU.

The full text of the EU declaration of conformity is available at the following internet address (refer to the product-specific pages): [www.microchip.com/design-centers/wireless-connectivity/](http://www.microchip.com/design-centers/wireless-connectivity/).

## 16. Document Revision History

Revision	Date	Section	Description
B	07/2020	<a href="#">7. Appendix A: BM83 EVB Reference Schematics</a>	<ul style="list-style-type: none"><li>• Added a note related to analog microphone gain</li><li>• Updated with schematics of <a href="#">Figure 7-9</a> and <a href="#">Figure 7-21</a></li></ul>
		<a href="#">15. Regulatory Approvals</a>	Added this chapter
A	07/2019	Document	Initial Revision



## The Microchip Website

---

Microchip provides online support via our website at [www.microchip.com/](http://www.microchip.com/). This website is used to make files and information easily available to customers. Some of the content available includes:

- **Product Support** – Data sheets and errata, application notes and sample programs, design resources, user's guides and hardware support documents, latest software releases and archived software
- **General Technical Support** – Frequently Asked Questions (FAQs), technical support requests, online discussion groups, Microchip design partner program member listing
- **Business of Microchip** – Product selector and ordering guides, latest Microchip press releases, listing of seminars and events, listings of Microchip sales offices, distributors and factory representatives

## Product Change Notification Service

---

Microchip's product change notification service helps keep customers current on Microchip products. Subscribers will receive email notification whenever there are changes, updates, revisions or errata related to a specified product family or development tool of interest.

To register, go to [www.microchip.com/pcn](http://www.microchip.com/pcn) and follow the registration instructions.

## Customer Support

---

Users of Microchip products can receive assistance through several channels:

- Distributor or Representative
- Local Sales Office
- Embedded Solutions Engineer (ESE)
- Technical Support

Customers should contact their distributor, representative or ESE for support. Local sales offices are also available to help customers. A listing of sales offices and locations is included in this document.

Technical support is available through the website at: [www.microchip.com/support](http://www.microchip.com/support)

## Microchip Devices Code Protection Feature

---

Note the following details of the code protection feature on Microchip devices:

- Microchip products meet the specification contained in their particular Microchip Data Sheet.
- Microchip believes that its family of products is one of the most secure families of its kind on the market today, when used in the intended manner and under normal conditions.
- There are dishonest and possibly illegal methods used to breach the code protection feature. All of these methods, to our knowledge, require using the Microchip products in a manner outside the operating specifications contained in Microchip's Data Sheets. Most likely, the person doing so is engaged in theft of intellectual property.
- Microchip is willing to work with the customer who is concerned about the integrity of their code.
- Neither Microchip nor any other semiconductor manufacturer can guarantee the security of their code. Code protection does not mean that we are guaranteeing the product as "unbreakable."

Code protection is constantly evolving. We at Microchip are committed to continuously improving the code protection features of our products. Attempts to break Microchip's code protection feature may be a violation of the Digital Millennium Copyright Act. If such acts allow unauthorized access to your software or other copyrighted work, you may have a right to sue for relief under that Act.

## Legal Notice

---

Information contained in this publication regarding device applications and the like is provided only for your convenience and may be superseded by updates. It is your responsibility to ensure that your application meets with

your specifications. MICROCHIP MAKES NO REPRESENTATIONS OR WARRANTIES OF ANY KIND WHETHER EXPRESS OR IMPLIED, WRITTEN OR ORAL, STATUTORY OR OTHERWISE, RELATED TO THE INFORMATION, INCLUDING BUT NOT LIMITED TO ITS CONDITION, QUALITY, PERFORMANCE, MERCHANTABILITY OR FITNESS FOR PURPOSE. Microchip disclaims all liability arising from this information and its use. Use of Microchip devices in life support and/or safety applications is entirely at the buyer's risk, and the buyer agrees to defend, indemnify and hold harmless Microchip from any and all damages, claims, suits, or expenses resulting from such use. No licenses are conveyed, implicitly or otherwise, under any Microchip intellectual property rights unless otherwise stated.

---

## Trademarks

---

The Microchip name and logo, the Microchip logo, Adaptec, AnyRate, AVR, AVR logo, AVR Freaks, BesTime, BitCloud, chipKIT, chipKIT logo, CryptoMemory, CryptoRF, dsPIC, FlashFlex, flexPWR, HELDO, IGLOO, JukeBlox, KeeLoq, Kleer, LANCheck, LinkMD, maXStylus, maXTouch, MediaLB, megaAVR, Microsemi, Microsemi logo, MOST, MOST logo, MPLAB, OptoLyzer, PackeTime, PIC, picoPower, PICSTART, PIC32 logo, PolarFire, Prochip Designer, QTouch, SAM-BA, SenGenuity, SpyNIC, SST, SST Logo, SuperFlash, Symmetricom, SyncServer, Tachyon, TempTrackr, TimeSource, tinyAVR, UNI/O, Vectron, and XMEGA are registered trademarks of Microchip Technology Incorporated in the U.S.A. and other countries.

APT, ClockWorks, The Embedded Control Solutions Company, EtherSynch, FlashTec, Hyper Speed Control, HyperLight Load, IntelliMOS, Libero, motorBench, mTouch, Powermite 3, Precision Edge, ProASIC, ProASIC Plus, ProASIC Plus logo, Quiet-Wire, SmartFusion, SyncWorld, Temux, TimeCesium, TimeHub, TimePictra, TimeProvider, Vite, WinPath, and ZL are registered trademarks of Microchip Technology Incorporated in the U.S.A.

Adjacent Key Suppression, AKS, Analog-for-the-Digital Age, Any Capacitor, AnyIn, AnyOut, BlueSky, BodyCom, CodeGuard, CryptoAuthentication, CryptoAutomotive, CryptoCompanion, CryptoController, dsPICDEM, dsPICDEM.net, Dynamic Average Matching, DAM, ECAN, EtherGREEN, In-Circuit Serial Programming, ICSP, INICnet, Inter-Chip Connectivity, JitterBlocker, KleerNet, KleerNet logo, memBrain, Mindi, MiWi, MPASM, MPF, MPLAB Certified logo, MPLIB, MPLINK, MultiTRAK, NetDetach, Omniscient Code Generation, PICDEM, PICDEM.net, PICkit, PICtail, PowerSmart, PureSilicon, QMatrix, REAL ICE, Ripple Blocker, SAM-ICE, Serial Quad I/O, SMART-I.S., SQI, SuperSwitcher, SuperSwitcher II, Total Endurance, TSHARC, USBCheck, VariSense, ViewSpan, WiperLock, Wireless DNA, and ZENA are trademarks of Microchip Technology Incorporated in the U.S.A. and other countries.

SQTP is a service mark of Microchip Technology Incorporated in the U.S.A.

The Adaptec logo, Frequency on Demand, Silicon Storage Technology, and Symmcom are registered trademarks of Microchip Technology Inc. in other countries.

GestIC is a registered trademark of Microchip Technology Germany II GmbH & Co. KG, a subsidiary of Microchip Technology Inc., in other countries.

All other trademarks mentioned herein are property of their respective companies.

© 2019, Microchip Technology Incorporated, Printed in the U.S.A., All Rights Reserved.

ISBN: 978-1-5224-6343-6

---

## Quality Management System

---

For information regarding Microchip's Quality Management Systems, please visit [www.microchip.com/quality](http://www.microchip.com/quality).

## Worldwide Sales and Service

AMERICAS	ASIA/PACIFIC	ASIA/PACIFIC	EUROPE
<p><b>Corporate Office</b> 2355 West Chandler Blvd. Chandler, AZ 85224-6199 Tel: 480-792-7200 Tel: 480-792-7277 Technical Support: <a href="http://www.microchip.com/support">www.microchip.com/support</a> Web Address: <a href="http://www.microchip.com">www.microchip.com</a></p> <p><b>Atlanta</b> Duluth, GA Tel: 678-957-9614 Fax: 678-957-1455</p> <p><b>Austin, TX</b> Tel: 512-257-3370</p> <p><b>Boston</b> Westborough, MA Tel: 774-760-0087 Fax: 774-760-0088</p> <p><b>Chicago</b> Itasca, IL Tel: 630-285-0071 Fax: 630-285-0075</p> <p><b>Dallas</b> Addison, TX Tel: 972-818-7423 Fax: 972-818-2924</p> <p><b>Detroit</b> Novi, MI Tel: 248-848-4000</p> <p><b>Houston, TX</b> Tel: 281-894-5983</p> <p><b>Indianapolis</b> Noblesville, IN Tel: 317-773-8323 Fax: 317-773-5453 Tel: 317-536-2380</p> <p><b>Los Angeles</b> Mission Viejo, CA Tel: 949-462-9523 Fax: 949-462-9608 Tel: 951-273-7800</p> <p><b>Raleigh, NC</b> Tel: 919-844-7510</p> <p><b>New York, NY</b> Tel: 631-435-6000</p> <p><b>San Jose, CA</b> Tel: 408-735-9110 Tel: 408-436-4270</p> <p><b>Canada - Toronto</b> Tel: 905-695-1980 Fax: 905-695-2078</p>	<p><b>Australia - Sydney</b> Tel: 61-2-9868-6733</p> <p><b>China - Beijing</b> Tel: 86-10-8569-7000</p> <p><b>China - Chengdu</b> Tel: 86-28-8665-5511</p> <p><b>China - Chongqing</b> Tel: 86-23-8980-9588</p> <p><b>China - Dongguan</b> Tel: 86-769-8702-9880</p> <p><b>China - Guangzhou</b> Tel: 86-20-8755-8029</p> <p><b>China - Hangzhou</b> Tel: 86-571-8792-8115</p> <p><b>China - Hong Kong SAR</b> Tel: 852-2943-5100</p> <p><b>China - Nanjing</b> Tel: 86-25-8473-2460</p> <p><b>China - Qingdao</b> Tel: 86-532-8502-7355</p> <p><b>China - Shanghai</b> Tel: 86-21-3326-8000</p> <p><b>China - Shenyang</b> Tel: 86-24-2334-2829</p> <p><b>China - Shenzhen</b> Tel: 86-755-8864-2200</p> <p><b>China - Suzhou</b> Tel: 86-186-6233-1526</p> <p><b>China - Wuhan</b> Tel: 86-27-5980-5300</p> <p><b>China - Xian</b> Tel: 86-29-8833-7252</p> <p><b>China - Xiamen</b> Tel: 86-592-2388138</p> <p><b>China - Zhuhai</b> Tel: 86-756-3210040</p>	<p><b>India - Bangalore</b> Tel: 91-80-3090-4444</p> <p><b>India - New Delhi</b> Tel: 91-11-4160-8631</p> <p><b>India - Pune</b> Tel: 91-20-4121-0141</p> <p><b>Japan - Osaka</b> Tel: 81-6-6152-7160</p> <p><b>Japan - Tokyo</b> Tel: 81-3-6880-3770</p> <p><b>Korea - Daegu</b> Tel: 82-53-744-4301</p> <p><b>Korea - Seoul</b> Tel: 82-2-554-7200</p> <p><b>Malaysia - Kuala Lumpur</b> Tel: 60-3-7651-7906</p> <p><b>Malaysia - Penang</b> Tel: 60-4-227-8870</p> <p><b>Philippines - Manila</b> Tel: 63-2-634-9065</p> <p><b>Singapore</b> Tel: 65-6334-8870</p> <p><b>Taiwan - Hsin Chu</b> Tel: 886-3-577-8366</p> <p><b>Taiwan - Kaohsiung</b> Tel: 886-7-213-7830</p> <p><b>Taiwan - Taipei</b> Tel: 886-2-2508-8600</p> <p><b>Thailand - Bangkok</b> Tel: 66-2-694-1351</p> <p><b>Vietnam - Ho Chi Minh</b> Tel: 84-28-5448-2100</p>	<p><b>Austria - Wels</b> Tel: 43-7242-2244-39 Fax: 43-7242-2244-393</p> <p><b>Denmark - Copenhagen</b> Tel: 45-4450-2828 Fax: 45-4485-2829</p> <p><b>Finland - Espoo</b> Tel: 358-9-4520-820</p> <p><b>France - Paris</b> Tel: 33-1-69-53-63-20 Fax: 33-1-69-30-90-79</p> <p><b>Germany - Garching</b> Tel: 49-8931-9700</p> <p><b>Germany - Haan</b> Tel: 49-2129-3766400</p> <p><b>Germany - Heilbronn</b> Tel: 49-7131-72400</p> <p><b>Germany - Karlsruhe</b> Tel: 49-721-625370</p> <p><b>Germany - Munich</b> Tel: 49-89-627-144-0 Fax: 49-89-627-144-44</p> <p><b>Germany - Rosenheim</b> Tel: 49-8031-354-560</p> <p><b>Israel - Ra'anana</b> Tel: 972-9-744-7705</p> <p><b>Italy - Milan</b> Tel: 39-0331-742611 Fax: 39-0331-466781</p> <p><b>Italy - Padova</b> Tel: 39-049-7625286</p> <p><b>Netherlands - Drunen</b> Tel: 31-416-690399 Fax: 31-416-690340</p> <p><b>Norway - Trondheim</b> Tel: 47-72884388</p> <p><b>Poland - Warsaw</b> Tel: 48-22-3325737</p> <p><b>Romania - Bucharest</b> Tel: 40-21-407-87-50</p> <p><b>Spain - Madrid</b> Tel: 34-91-708-08-90 Fax: 34-91-708-08-91</p> <p><b>Sweden - Gothenberg</b> Tel: 46-31-704-60-40</p> <p><b>Sweden - Stockholm</b> Tel: 46-8-5090-4654</p> <p><b>UK - Wokingham</b> Tel: 44-118-921-5800 Fax: 44-118-921-5820</p>