

BG95xA-GL&BG950S-GL

TE-B User Guide

LPWA Module Series

Version: 1.0

Date: 2023-10-20

Status: Released



At Quectel, our aim is to provide timely and comprehensive services to our customers. If you require any assistance, please contact our headquarters:

Quectel Wireless Solutions Co., Ltd.

Building 5, Shanghai Business Park Phase III (Area B), No.1016 Tianlin Road, Minhang District, Shanghai 200233, China

Tel: +86 21 5108 6236

Email: info@quectel.com

Or our local offices. For more information, please visit:

<http://www.quectel.com/support/sales.htm>.

For technical support, or to report documentation errors, please visit:

<http://www.quectel.com/support/technical.htm>.

Or email us at: support@quectel.com.

Legal Notices

We offer information as a service to you. The provided information is based on your requirements and we make every effort to ensure its quality. You agree that you are responsible for using independent analysis and evaluation in designing intended products, and we provide reference designs for illustrative purposes only. Before using any hardware, software or service guided by this document, please read this notice carefully. Even though we employ commercially reasonable efforts to provide the best possible experience, you hereby acknowledge and agree that this document and related services hereunder are provided to you on an “as available” basis. We may revise or restate this document from time to time at our sole discretion without any prior notice to you.

Use and Disclosure Restrictions

License Agreements

Documents and information provided by us shall be kept confidential, unless specific permission is granted. They shall not be accessed or used for any purpose except as expressly provided herein.

Copyright

Our and third-party products hereunder may contain copyrighted material. Such copyrighted material shall not be copied, reproduced, distributed, merged, published, translated, or modified without prior written consent. We and the third party have exclusive rights over copyrighted material. No license shall be granted or conveyed under any patents, copyrights, trademarks, or service mark rights. To avoid ambiguities, purchasing in any form cannot be deemed as granting a license other than the normal non-exclusive, royalty-free license to use the material. We reserve the right to take legal action for noncompliance with abovementioned requirements, unauthorized use, or other illegal or malicious use of the material.

Trademarks

Except as otherwise set forth herein, nothing in this document shall be construed as conferring any rights to use any trademark, trade name or name, abbreviation, or counterfeit product thereof owned by Quectel or any third party in advertising, publicity, or other aspects.

Third-Party Rights

This document may refer to hardware, software and/or documentation owned by one or more third parties (“third-party materials”). Use of such third-party materials shall be governed by all restrictions and obligations applicable thereto.

We make no warranty or representation, either express or implied, regarding the third-party materials, including but not limited to any implied or statutory, warranties of merchantability or fitness for a particular purpose, quiet enjoyment, system integration, information accuracy, and non-infringement of any third-party intellectual property rights with regard to the licensed technology or use thereof. Nothing herein constitutes a representation or warranty by us to either develop, enhance, modify, distribute, market, sell, offer for sale, or otherwise maintain production of any our products or any other hardware, software, device, tool, information, or product. We moreover disclaim any and all warranties arising from the course of dealing or usage of trade.

Privacy Policy

To implement module functionality, certain device data are uploaded to Quectel’s or third-party’s servers, including carriers, chipset suppliers or customer-designated servers. Quectel, strictly abiding by the relevant laws and regulations, shall retain, use, disclose or otherwise process relevant data for the purpose of performing the service only or as permitted by applicable laws. Before data interaction with third parties, please be informed of their privacy and data security policy.

Disclaimer

- a) We acknowledge no liability for any injury or damage arising from the reliance upon the information.
- b) We shall bear no liability resulting from any inaccuracies or omissions, or from the use of the information contained herein.
- c) While we have made every effort to ensure that the functions and features under development are free from errors, it is possible that they could contain errors, inaccuracies, and omissions. Unless otherwise provided by valid agreement, we make no warranties of any kind, either implied or express, and exclude all liability for any loss or damage suffered in connection with the use of features and functions under development, to the maximum extent permitted by law, regardless of whether such loss or damage may have been foreseeable.
- d) We are not responsible for the accessibility, safety, accuracy, availability, legality, or completeness of information, advertising, commercial offers, products, services, and materials on third-party websites and third-party resources.

Copyright © Quectel Wireless Solutions Co., Ltd. 2023. All rights reserved.

Safety Information

The following safety precautions must be observed during all phases of operation, such as usage, service or repair of any terminal or mobile incorporating the module. Manufacturers of the terminal should notify users and operating personnel of the following safety information by incorporating these guidelines into all manuals of the product. Otherwise, Quectel assumes no liability for customers' failure to comply with these precautions.



Full attention must be paid to driving at all times in order to reduce the risk of an accident. Using a mobile while driving (even with a handsfree kit) causes distraction and can lead to an accident. Please comply with laws and regulations restricting the use of wireless devices while driving.



Switch off the terminal or mobile before boarding an aircraft. The operation of wireless appliances in an aircraft is forbidden to prevent interference with communication systems. If there is an Airplane Mode, it should be enabled prior to boarding an aircraft. Please consult the airline staff for more restrictions on the use of wireless devices on an aircraft.



Wireless devices may cause interference on sensitive medical equipment, so please be aware of the restrictions on the use of wireless devices when in hospitals, clinics or other healthcare facilities.



Terminals or mobiles operating over radio signal and cellular network cannot be guaranteed to connect in certain conditions, such as when the mobile bill is unpaid or the (U)SIM card is invalid. When emergent help is needed in such conditions, use emergency call if the device supports it. In order to make or receive a call, the terminal or mobile must be switched on in a service area with adequate cellular signal strength. In an emergency, the device with emergency call function cannot be used as the only contact method considering network connection cannot be guaranteed under all circumstances.



The terminal or mobile contains a transceiver. When it is ON, it receives and transmits radio frequency signals. RF interference can occur if it is used close to TV sets, radios, computers or other electric equipment.



In locations with explosive or potentially explosive atmospheres, obey all posted signs and turn off wireless devices such as mobile phone or other terminals. Areas with explosive or potentially explosive atmospheres include fueling areas, below decks on boats, fuel or chemical transfer or storage facilities, and areas where the air contains chemicals or particles such as grain, dust or metal powders.

About the Document

Revision History

Version	Date	Author	Description
-	2023-07-26	Arvin WU	Creation of the document
1.0	2023-10-20	Arvin WU	First official release

Contents

Safety Information.....	3
About the Document.....	4
Contents.....	5
Table Index.....	6
Figure Index.....	7
1 Introduction	8
2 Product Overview	9
2.1. Top and Bottom Views	9
2.2. Components & Interfaces Placement	11
2.3. Key Features.....	14
2.4. Functional Diagram.....	16
3 Kit Accessories & Assembly	17
3.1. Accessories List	17
3.2. Accessories Assembly	18
4 Operation Procedures	19
4.1. Operation Procedure with Single Board	19
4.1.1. Interface Diagram of Using TE-B Alone.....	19
4.1.2. Operation Procedures of Using TE-B Alone	20
4.2. Power Consumption Test Guide	21
4.2.1. Test Tools	21
4.2.2. Modify TE-B.....	21
4.2.3. Test Procedures of Power Consumption	22
5 Appendix References	24

Table Index

Table 1: Components & Interfaces Information.....	12
Table 2: Key Features of TE-B	14
Table 3: Accessories List.....	17
Table 4: Related Documents	24
Table 5: Terms and Abbreviations	24

Figure Index

Figure 1: Top View.....	9
Figure 2: Bottom View.....	10
Figure 3: Top Components & Interfaces Placement.....	11
Figure 4: Bottom Components & Interfaces Placement.....	12
Figure 5: Functional Diagram of TE-B.....	16
Figure 6: TE-B Kit Accessories.....	17
Figure 7: TE-B Kit Accessories Assembly.....	18
Figure 8: Interface Diagram of Using TE-B Alone.....	19
Figure 9: USB-to-UART Interface Displayed on PC.....	21
Figure 10: Schematic Diagram of TE-B Before Modification.....	22
Figure 11: Wiring Diagram.....	23

1 Introduction

This user guide describes the application details of BG95xA-GL and BG950S-GL TE-B, which is an assistant tool for engineers to develop applications and test basic functionalities of Quectel BG950A-GL, BG951A-GL, BG952A-GL, BG953A-GL, BG955A-GL and BG950S-GL. This document will take BG950A-GL TE-B as a representative to introduce BG95xA-GL and BG950S-GL TE-B.

2 Product Overview

BG95xA-GL & BG950S-GL TE-B is a LPWA development board, which can be used alone to develop and debug applications. It communicates with infrastructures of mobile network operators through LPWA radio protocols in 3GPP Rel-13 and 3GPP Rel-14.

2.1. Top and Bottom Views

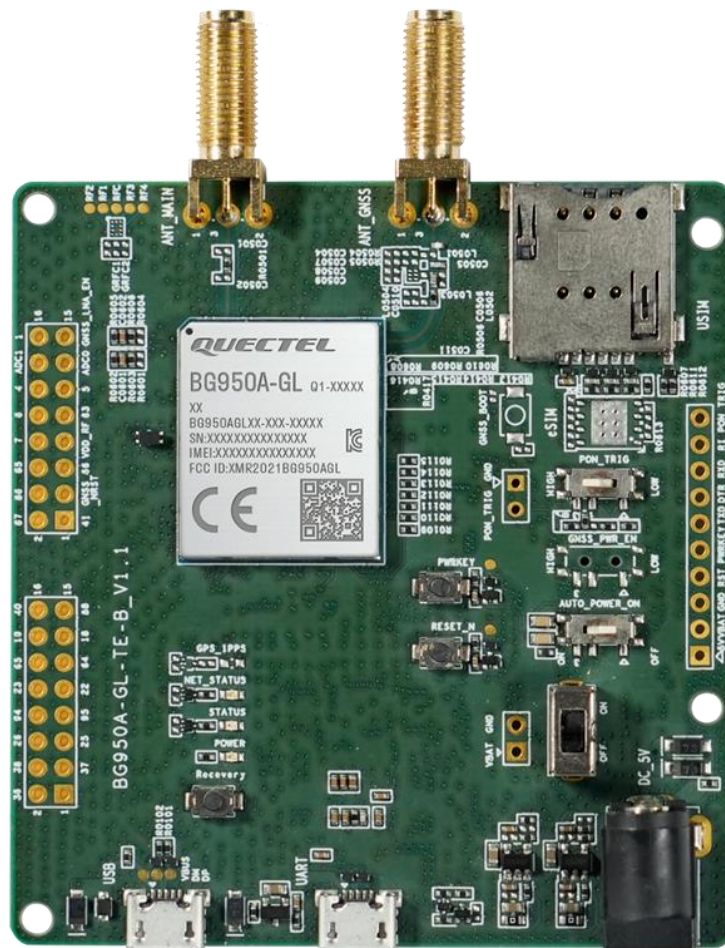

Figure 1: Top View

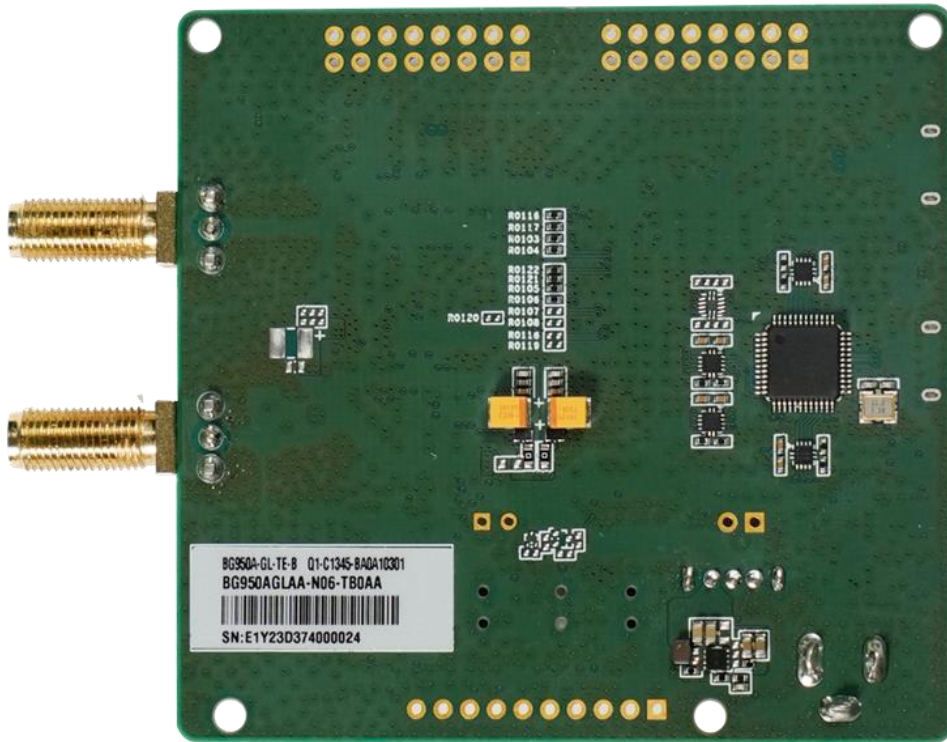

Figure 2: Bottom View

NOTE

Pictures above are for reference only.

2.2. Components & Interfaces Placement

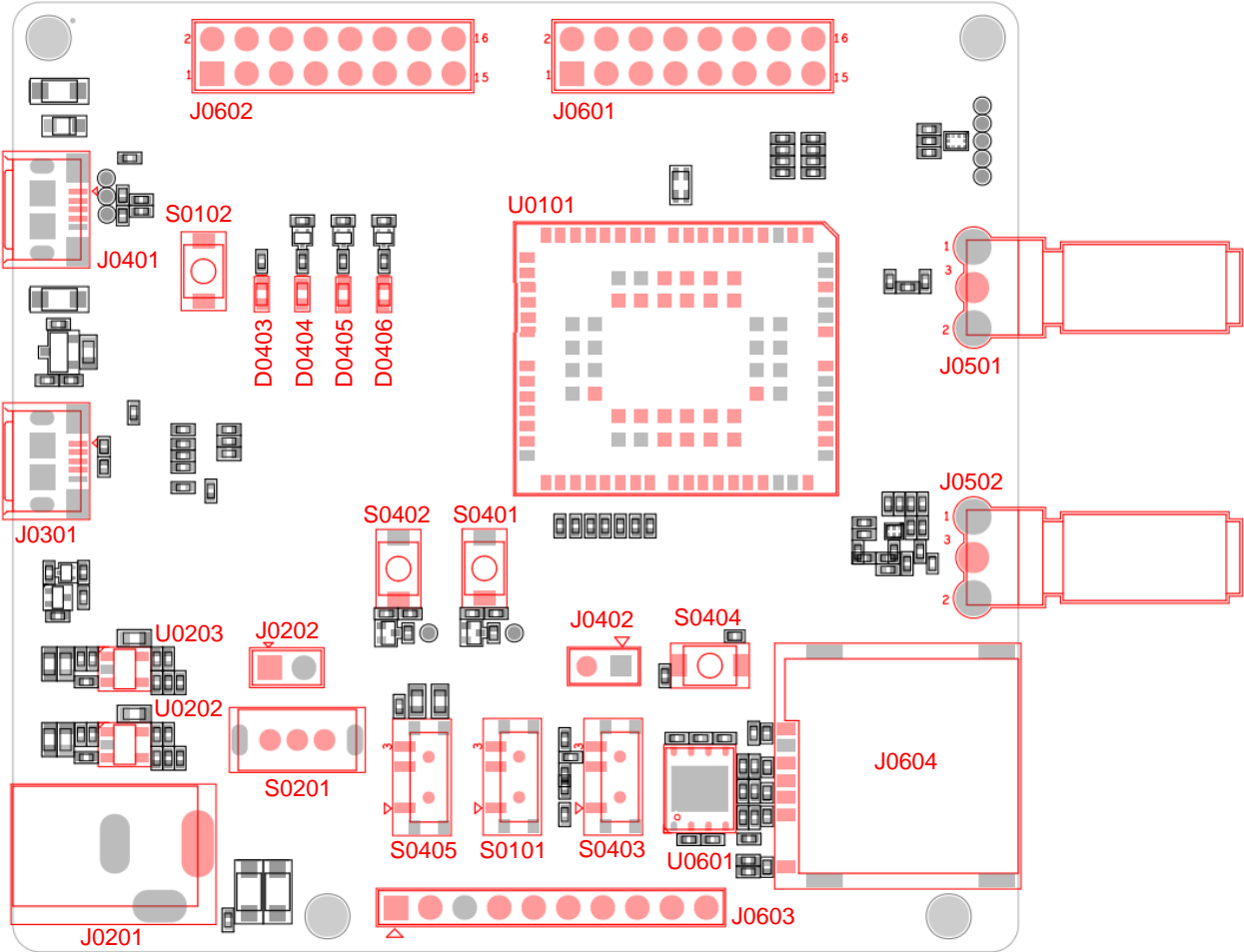

Figure 3: Top Components & Interfaces Placement

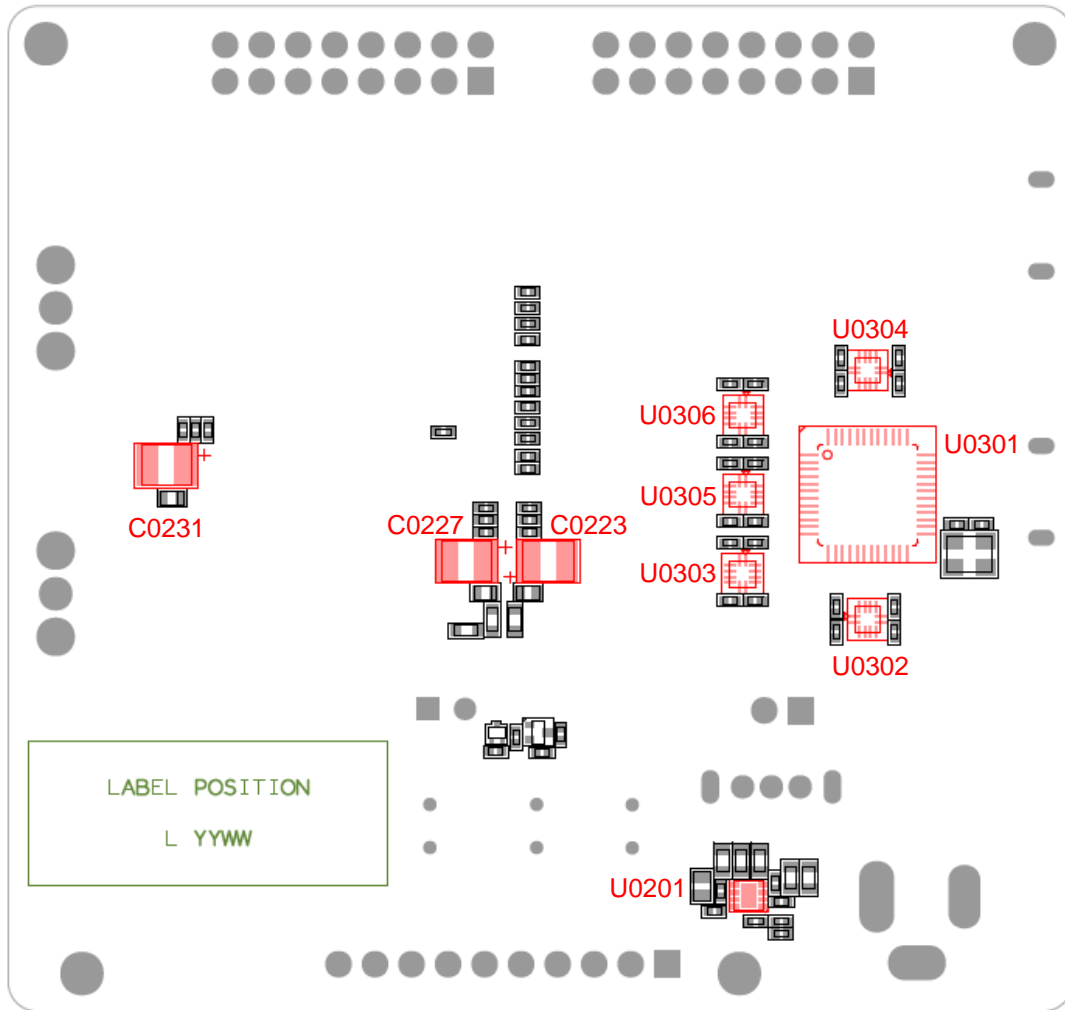

Figure 4: Bottom Components & Interfaces Placement

Table 1: Components & Interfaces Information

Components/Interfaces	RefDes	Description
BG95xA-GL/ BG950S-GL	U0101	BG95xA-GL & BG950S-GL module
DC-DC	U0201	DC-DC converter
LDO	U0202	3.3 V low dropout voltage linear regulator
	U0203	1.8 V low dropout voltage linear regulator
USB-to-UART Bridge	U0301	USB to UART bridge controller
Voltage-level Translators	U0302, U0303, U0304, U0305, U0306	Bidirectional voltage-level translator

eSIM	U0601	1.8 V eSIM card
Power Supply Interfaces	J0301, J0401	USB power supply interface
	J0201	Power adapter power supply interface
	J0202	External power supply interface
USB-to-UART Interface	J0301	UART interface
USB Interface	J0401	USB interface
Main Antenna Interface	J0501	RF SMA connector
GNSS Antenna Interface	J0502	GNSS SMA connector
Test Points	J0402, J0601, J0602, J0603	Test pins
USIM Interface	J0604	Micro SIM card connector
GNSS_EN Switch	S0101	Power switch only for BG951A-GL module
Recovery Button	S0102	Forced into download mode for BB chip
Power Switch	S0201	Power switch
PWRKEY Button	S0401	Turn on/off the module
RESET_N Button	S0402	Reset the module
PON_TRIG Switch	S0403	<ul style="list-style-type: none"> ● Enter/exit e-I-DRX, sleep mode, PSM or turn off mode ● Enable/disable the main UART
GNSS_BOOT Button	S0404	Forced into download mode only for BG951A-GL GNSS chip
AUTO_POWER_ON Switch	S0405	Power on automatically
Power Indicator	D0403	Indicate the power up/down status
STATUS	D0404	Indicate the operation status
NETLIGHT	D0405	Indicate the network connection status
GPS_1PPS	D0406	Indicate GNSS pulses per second status
Tantalum Capacitors	C0223, C0227, C0231	Used for the front-end module energy storage

2.3. Key Features

Table 2: Key Features of TE-B

Parameter	Details
Power Supply	USB interface: <ul style="list-style-type: none"> ● Supply voltage range: 4.75–5.25 V ● Typical supply voltage: 5.0 V Power adapter interface: <ul style="list-style-type: none"> ● Supply voltage range: 4.75–5.25 V ● Typical supply voltage: 5.0 V
Transmitting Power	23 dBm \pm 2.7 dB
Temperature Ranges	<ul style="list-style-type: none"> ● Operating temperature range: -35 to +75 °C ¹ ● Extended temperature range: -40 to +85 °C ² ● Storage temperature range: -40 to +90 °C
USIM Interface	Support 1.8 V external USIM/eSIM card
PON_TRIG Switch	Used to enter/exit e-I-DRX, sleep mode, PSM and turn off mode. Enable/disable the main UART.
USB-to-UART Interface	BG95xA-GL: Main UART: <ul style="list-style-type: none"> ● Used for AT command communication and data transmission ● Baud rate: 115200 bps by default ● Default frame format: 8N1 (8 data bits, no parity, 1 stop bit) ● Supports RTS and CTS hardware flow control DM UART ³: <ul style="list-style-type: none"> ● Used for firmware upgrade, software debugging, DM log output, GNSS data and NMEA sentence output. ● Baud rate: 115200 bps by default ● Default frame format: 8N1 (8 data bits, no parity, 1 stop bit) ● Supports RTS and CTS hardware flow control

¹ To meet the normal operating temperature range requirements, it is necessary to ensure effective thermal dissipation, e.g., by adding passive or active heat sinks, heat pipes, vapor chambers. Within this range, the module's indicators comply with 3GPP specification requirements.

² To meet the extended operating temperature range requirements, it is necessary to ensure effective thermal dissipation, e.g., by adding passive or active heat sinks, heat pipes, vapor chambers. Within this range, the module retains the ability to establish and maintain functions such as voice, SMS, data transmission and emergency call, without any unrecoverable malfunction. Radio spectrum and radio network remain uninfluenced, whereas the value of one or more parameters, such as P_{out}, may decrease and fall below the range of the 3GPP specified tolerances. When the temperature returns to the normal operating temperature range, the module's indicators will comply with 3GPP specification requirements again.

³ BG951A-GL only supports one DM UART interface, while BG950A-GL, BG953A-GL and BG955A-GL support two DM UART interfaces, more precisely, pin 27 (DM_TXD1) and pin 28 (DM_RXD1) are connected to pin 95 (DM_TXD2) and pin 94 (DM_RXD2) respectively inside the module.

Debug UART:

- Used for RF calibration and SFP log output.
- Baud rate: 921600 bps by default
- Default frame format: 8N1 (8 data bits, no parity, 1 stop bit)
- Supports RTS and CTS hardware flow control

GNSS UART (Only BG951A-GL):

- Used for GNSS data and GNSS NMEA sentence output, and GNSS firmware upgrade
- Baud rate: 115200 bps by default

BG950S-GL:
Main UART:

- Used for AT command communication and data transmission
- Baud rate: 115200 bps by default
- Default frame format: 8N1 (8 data bits, no parity, 1 stop bit)
- Supports RTS and CTS hardware flow control

DM UARTs:

- Used for firmware upgrade, software debugging, RF calibration, log output, GNSS data and NMEA sentence output.
- Baud rate: 115200 bps by default
- Default frame format: 8N1 (8 data bits, no parity, 1 stop bit)
- Support RTS and CTS hardware flow control

RESET Button	Reset the module
PWRKEY Button	Turn on/off the module
Size	(70.0 +0.1/-0.15) mm × (74.0 +0.1/-0.15) mm × (1.6 ±0.16) mm
Firmware Upgrade	<ul style="list-style-type: none"> ● DM UART interface ● DFOTA
Antenna Interface	<ul style="list-style-type: none"> ● Main antenna interface (ANT_MAIN): 50 Ω impedance ● GNSS antenna interface (ANT_GNSS): 50 Ω impedance

2.4. Functional Diagram

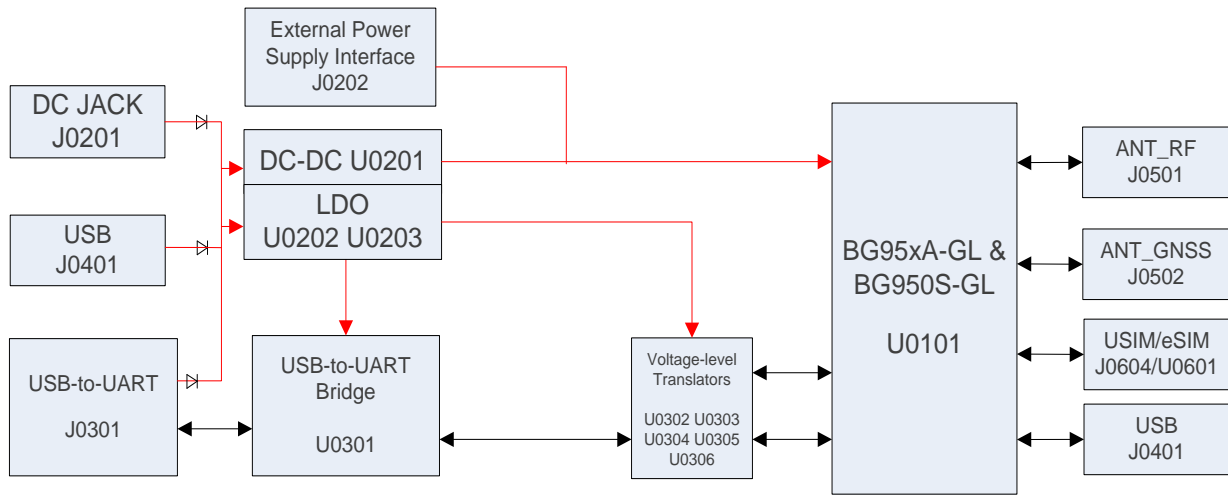

Figure 5: Functional Diagram of TE-B

3 Kit Accessories & Assembly

3.1. Accessories List



Figure 6: TE-B Kit Accessories

Table 3: Accessories List

Item	Description	Quantity (pcs)
Antenna	LTE antenna 699 MHz–2690 MHz SMA-J 200 mm	1
	External GPS antenna, black	1
Cable	Micro-USB cable	1

3.2. Accessories Assembly



Figure 7: TE-B Kit Accessories Assembly

NOTE

Pictures above are for reference only.

4 Operation Procedures

BG95xA-GL & BG950S-GL TE-B can be used alone to upgrade firmware, power consumption test and debug applications based on BG95xA-GL & BG950S-GL module. The following describes the operation procedures of using TE-B along.

4.1. Operation Procedure with Single Board

4.1.1. Interface Diagram of Using TE-B Alone

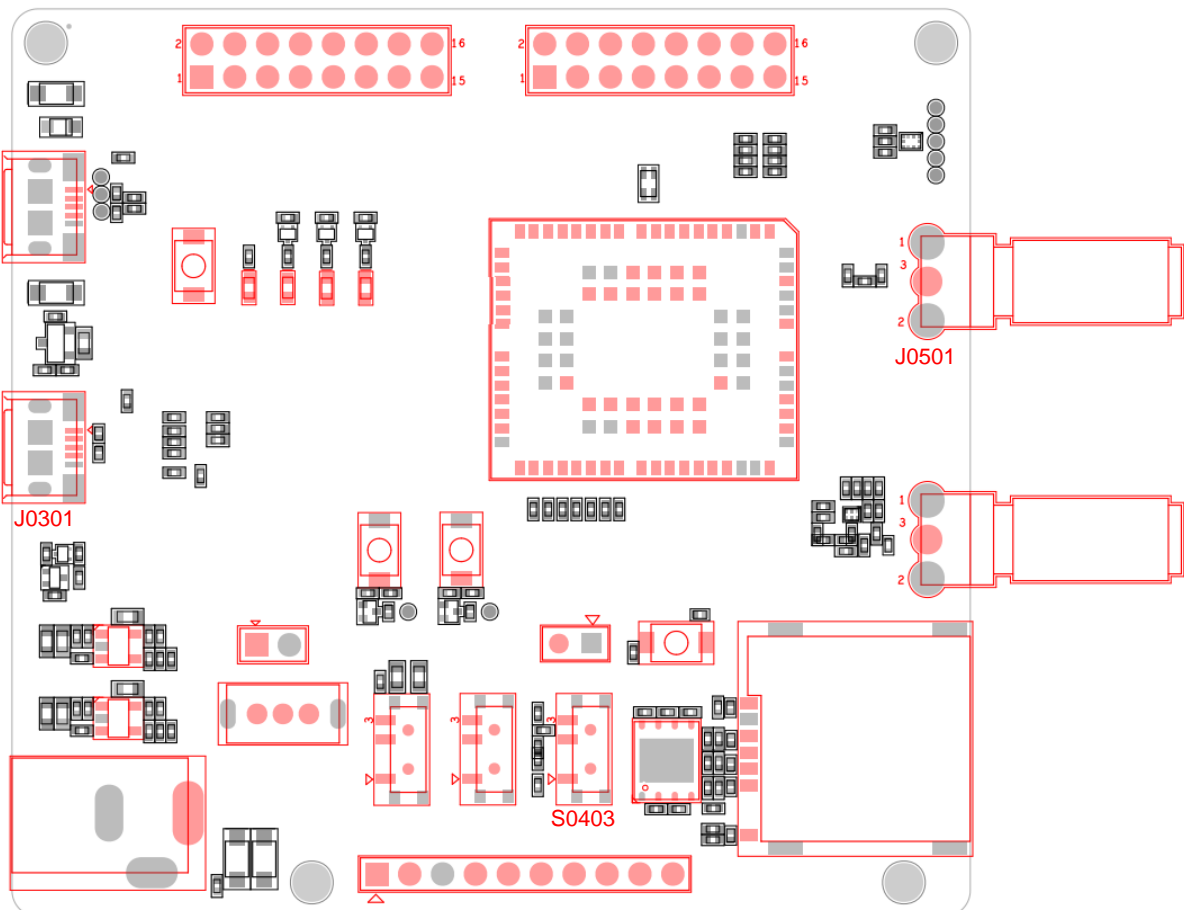

Figure 8: Interface Diagram of Using TE-B Alone

4.1.2. Operation Procedures of Using TE-B Alone

1. Install USB-to-UART driver which can be downloaded from the following link:
https://www.wch.cn/downloads/USBMSER_exe.html.
2. Insert a Micro-SIM card into J0604, and please note that a NB-IoT or Cat M USIM card should be selected according to actual needs.
3. Connect the rod antenna with SMA connector on J0501 (Main antenna connector).
4. Switch S0403 (PON_TRIG Switch) to "HIGH" state.
5. **BG95xA-GL:**
Connect the J0301 (USB-to-UART interface) with PC via a Micro-USB cable. After turning on TE-B, serial port information will be shown on "Device Manager" of PC.
 - 1) Among them, "**WCH USB-SERIAL Ch A (COM23)**" is connected to the main UART of BG95xA-GL, which can be used for data transmission and AT command communication.
 - 2) Among them, "**WCH USB-SERIAL Ch B (COM21)**" is connected to the debug UART of BG95xA-GL, which can be used for RF calibration and SFP log output.
 - 3) Among them, "**WCH USB-SERIAL Ch C (COM22)**" is connected to DM UART of BG95xA-GL, which can be used for firmware upgrade, software debugging, DM log output, GNSS data and NMEA sentences output.
 - 4) Among them, "**WCH USB-SERIAL Ch D (COM20)**" is connected to the GNSS UART of BG951A-GL, which can be used for GNSS data and GNSS NMEA sentence output, and GNSS firmware upgrade.
6. **BG950S-GL:**
Connect the J0301 (USB-to-UART interface) with PC via a Micro-USB cable. After turning on TE-B, serial port information will be shown on "Device Manager" of PC.
 - 1) Among them, "**WCH USB-SERIAL Ch A (COM23)**" is connected to the main UART of BG950S-GL, which can be used for data transmission and AT command communication.
 - 2) Among them, "**WCH USB-SERIAL Ch C (COM22)**" is connected to DM UARTs of BG950S-GL, which can be used for firmware upgrade, software debugging, RF calibration, log output, GNSS data and NMEA sentence output.

For details of UART configuration, see **document [1]** and **[2]**.



Figure 9: USB-to-UART Interface Displayed on PC

NOTE

In the procedures above, pressing S0402 (RESET_N button) at least 100 ms on the BG95xA-GL & BG950S-GL TE-B can reset the module.

4.2. Power Consumption Test Guide

4.2.1. Test Tools

The followings are the equipment and tools needed for the power consumption test:

- BG95xA-GL/BG950S-GL TE-B
- DC power analyzer
- Wire, soldering iron, tin wire, and wire stripping pliers, etc. to weld the power supply cord on TE-B.

This power consumption test guide is based on Keysight's N6705C DC power analyzer for testing.

4.2.2. Modify TE-B

If you use the TE-B to test the power consumption of the BG95xA-GL & BG950S-GL, you need to modify the TE-B as follows:

1. Switch S0201 (power switch) to "OFF" to disconnect the module from other parts.
2. Solder two wires respectively to the two pins (VBAT and GND) of the J0202. One wire is used as

VBAT, and the other is used as GND, so that the external power supply can supply power to the module separately.

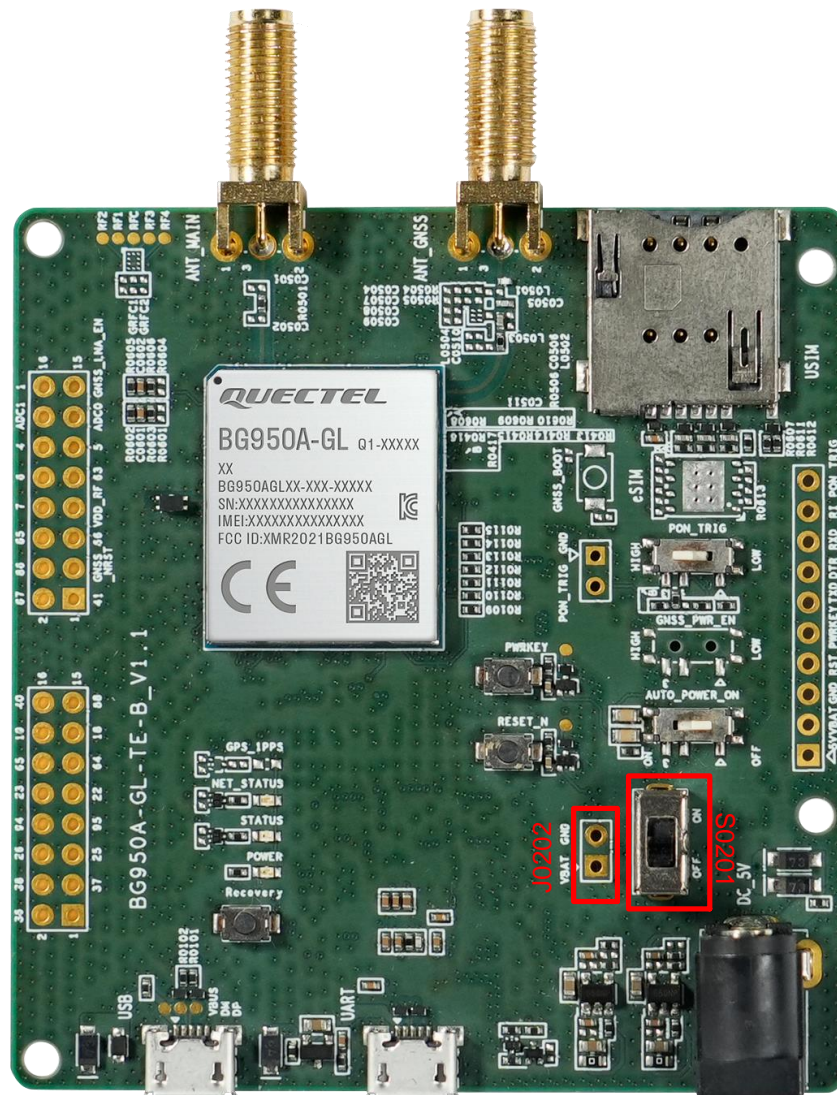

Figure 10: Schematic Diagram of TE-B Before Modification

4.2.3. Test Procedures of Power Consumption

Please refer to the following steps to test the current consumption of the module on the modified TE-B:

1. Insert the USIM card.
2. Connect the USB cable to J0301 (the USB-to-UART interface) of the TE-B.
3. After S0201 (the power switch) is turned off, set the output voltage on N6705C to 3.3 V or 3.8 V (only BG955A-GL), and connect the positive and negative wires of N6705C to the two wires (VBAT, GND) welded on J0202 to supply the module separately.

4. Turn on the output voltage set by N6705C, and turn on the module after power up.
5. Conduct current consumption tests in different operation modes.

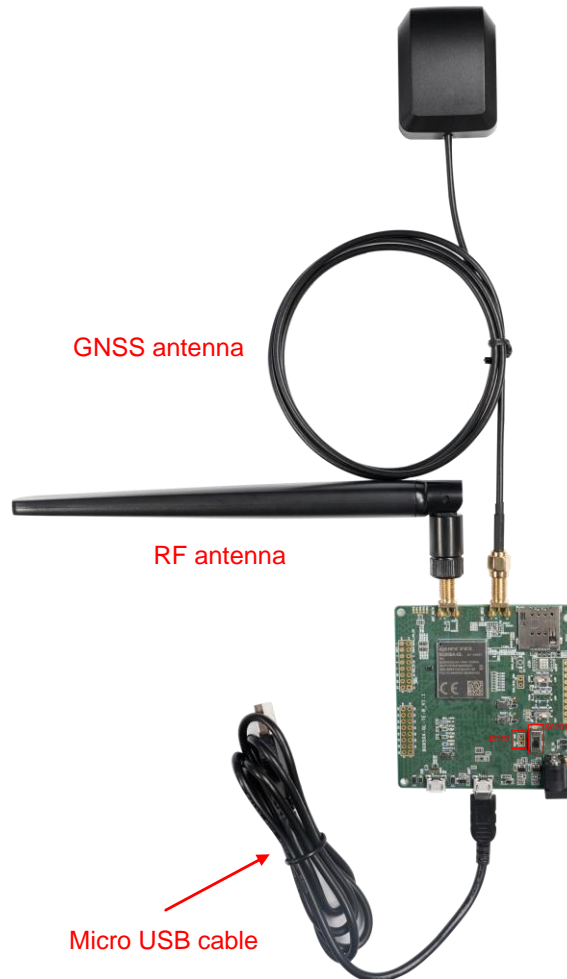

Figure 11: Wiring Diagram

5 Appendix References

Table 4: Related Documents

Document Name
[1] Quectel_BG95xA-GL_Hardware_Design
[2] Quectel_BG950S-GL_Hardware_Design

Table 5: Terms and Abbreviations

Abbreviation	Description
3GPP	3rd Generation Partnership Project
DC	Direct Current
DFOTA	Delta Firmware Upgrade Over-the-Air
GND	Ground
GNSS	Global Navigation Satellite System
LDO	Low-dropout Regulator
LPWA	Low-Power Wide-Area
NB-IoT	Narrowband Internet of Things
PC	Personal Computer
RF	Radio Frequency
SMA	Sub Miniature Version A
UART	Universal Asynchronous Receiver & Transmitter
USB	Universal Serial Bus
USIM	Universal Subscriber Identification Module
VBAT	Voltage at Battery