

Types B, 2B, C, 2C, 3C, M, Q, 2Q, R, R (HE 11), 2R

Page

Technical characteristics		01.10
Type B connectors		01.11
Type 2B connectors		01.16
Type C connectors		01.18
Type 2C connectors		01.24
Type 3C connectors		01.26
Type M-flat connectors		01.27
Type M connectors		01.28
Special contacts type M		01.30
Type R connectors		01.32
Type R (HE 11) connectors		01.34
Type Q, 2Q and 2R connectors		01.36
Pin shroud		01.40
Application examples		01.42
Coding systems		01.44

DIN Signal
to 2 A

Number of contacts	16-96
Contact spacing (mm)	2.54
Working current	2 A max. see current carrying capacity chart
Clearance	≥ 1.2 mm
Creepage	≥ 1.2 mm
Working voltage	2 A max. 1 A with insulation displacement 40 A max. type M
Test voltage $U_{r.m.s.}$	1 kV
Contact resistance	≤ 15 mΩ for wire wrap connection ≤ 20 mΩ including crimp connection
Insulation resistance	≥ 10 ¹² Ω
Temperature range	- 55 °C ... + 125 °C The higher temperature limit includes the local ambient and heating effects of the contacts under load
Degree of protection for crimp terminal IP 20	according to DIN 40 050
Electrical termination	
Male connector	Solder pins for pcb connections Ø 1.0 ± 0.1 mm according to IEC 60 326-3 wrap posts 0.6 x 0.6 mm diagonal 0.79-0.86 mm
Female connector	wrap posts 0.6 x 0.6 mm diagonal 0.79-0.86 mm Solder pins for pcb connections Ø 1.0 ± 0.1 mm according to IEC 60 326-3 Crimp terminal 0.09-0.5 mm ² Insulation displacement connection AWG 28/7
Insertion and withdrawal force	16way ≤ 15 N 30way ≤ 30 N 32way ≤ 30 N 48way ≤ 45 N 64way ≤ 60 N 96way ≤ 90 N
Materials	
Mouldings	Thermoplastic resin, glass-fibre filled, UL 94-V0
Contacts	Copper alloy
Contact surface	
Contact zone	Selectively plated according to performance level ¹⁾

Current carrying capacity

The current carrying capacity is limited by maximum temperature of materials for inserts and contacts including terminals. The current capacity curve is valid for continuous, non interrupted current loaded contacts of connectors when simultaneous power on all contacts is given, without exceeding the maximum temperature.

Control and test procedures according to DIN IEC 60 512

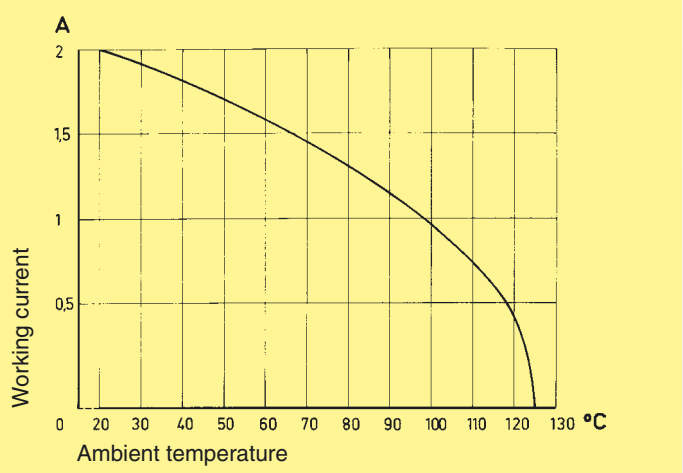

Pin shroud for female connectors with 0.6 x 0.6 mm pins

A secure interfacing system for signals from the rear of 19" racks to connectors with wrap posts 0.6 x 0.6 mm is possible with the use of a pin shroud.

The pin shroud protects the wrap posts on the rear side of the rack and can be screwed to the printed circuit board.

After assembly the rear ends of the wire wrap posts become the mating areas of the type C resp. type 2C male connector.

This system can now accept:

- female connectors type C
- female connectors type 2C
- female connectors type R
- female connectors type 2R

The locking levers provide security for the mated connectors. Fast and simple disconnection is possible (see application examples, pages 01.42 and 01.43).

Fitting and removing crimp contacts

see technical characteristics chapter 02

¹⁾ Explanation performance levels see chapter 00

Number of contacts

64, 32



Male connectors

Identification	Number of contacts	Contact arrangement	Part No.	Performance levels according to IEC 60 603-2. Explanation chapter 00		
				3	2	1
Male connector with angled solder pins	64		09 02 164 7921	09 02 164 6921 09 02 364 6921 ^{b)} 09 02 664 6921 ^{c)}	09 02 164 2921	
	32		09 02 132 7921	09 02 132 6921 09 02 632 6921 ^{c)}	09 02 132 2921	
	32		09 02 132 7931	09 02 132 6931 09 02 332 6931 ^{b)}	09 02 132 2931	
	62 + 2 [▲]			09 02 164 6951		
Male connector with straight solder pins	64		09 02 164 7922	09 02 164 6922	09 02 164 2922	
	32		09 02 132 7922	09 02 132 6922		
	32			09 02 132 6932		
	62 + 2 [▲]			09 02 164 6952	09 02 164 2952	

Dimensions

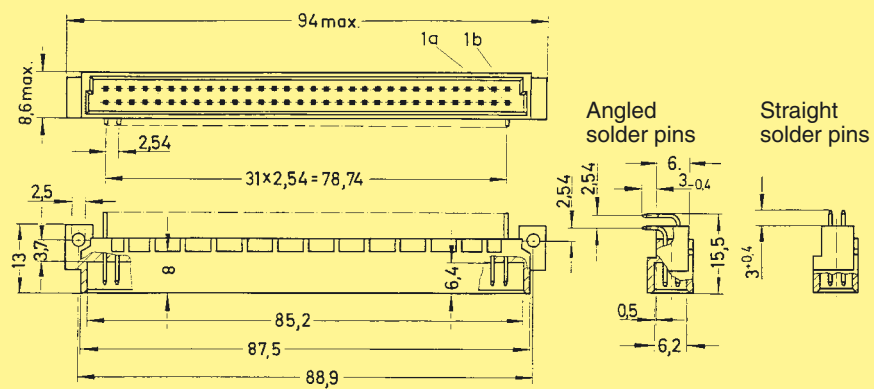

Board drillings

Mounting side

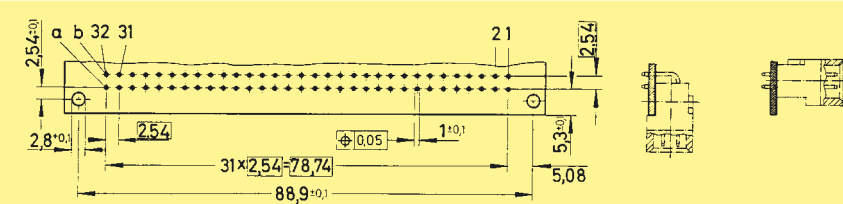

Dimensions in mm

[▲] Male connectors with 2 leading contacts [(0.8 mm) pos. a1 and a32]. Lagging pins row b on request.

Other contact arrangements on request

^{b)} Connectors with snap-in clips see chapter 00

^{c)} Connectors with coding see page 01.44

Number of contacts

64

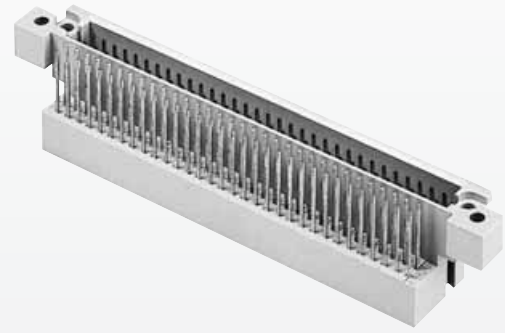

Interface connector U

DIN Signal to 2 A

Identification	Number of contacts	Part No.	Drawing	Dimensions in mm
----------------	--------------------	----------	---------	------------------

Interface connector U with wrap posts 0.6 x 0.6 mm

64

Performance level 1 acc. to IEC 60 603-2

09 02 064 2981

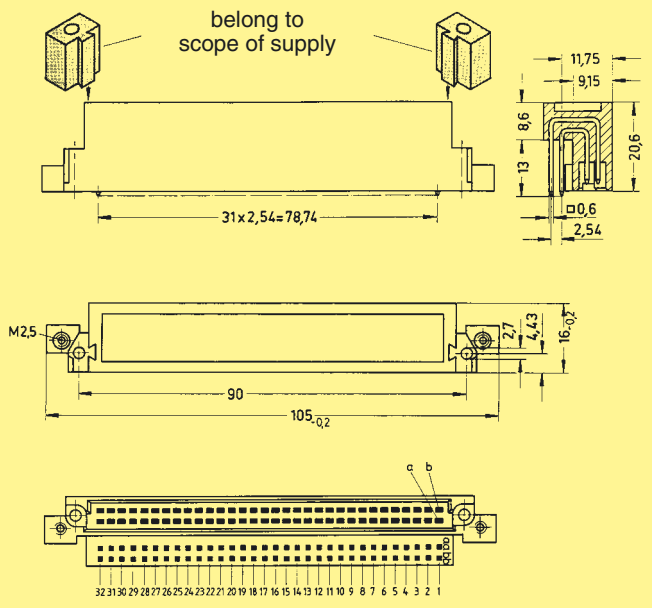

Locking screw

09 02 000 9923¹⁾

¹⁾ Order 2 pieces for one interface connector U



Mounting example

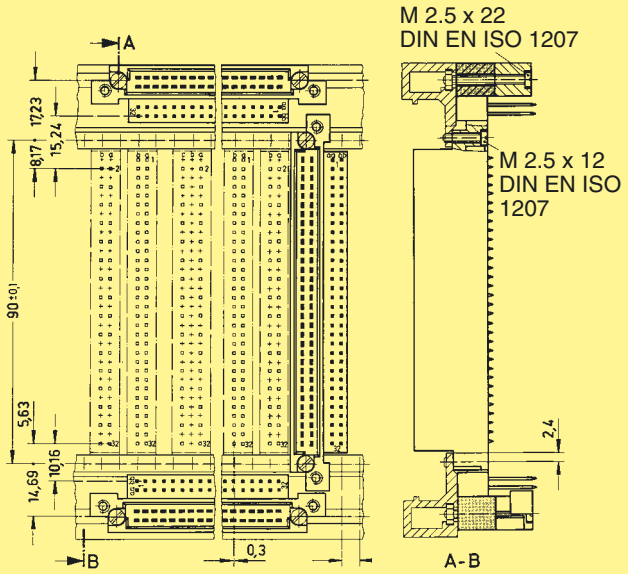

Number of contacts

64

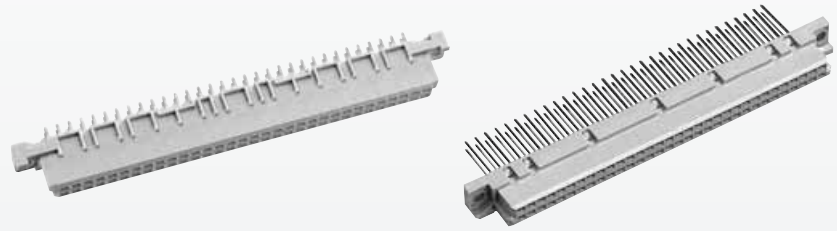

Female connectors

Identification	Number of contacts	Contact arrangement	Part No.	Performance levels according to IEC 60 603-2. Explanation chapter 00		
				3	2	1
Female connector with solder pins 2.9 mm	64		Performance level 3 on request	09 02 264 6824	Performance level 1 on request	
Female connector with solder pins 4.5 mm	64			09 02 464 6824 ^{b)}		
Female connector with solder pins 13 mm	64			09 02 764 6824 ^{c)}		
Female connector with wrap posts 13 mm	64			09 02 264 6825		
Female connector with wrap posts 13 mm	64		09 02 264 6421			
Female connector with wrap posts 13 mm	64		09 02 264 6821			

Female connector with press-in pins

Part Nos. and variants see chapter 04

Dimensions

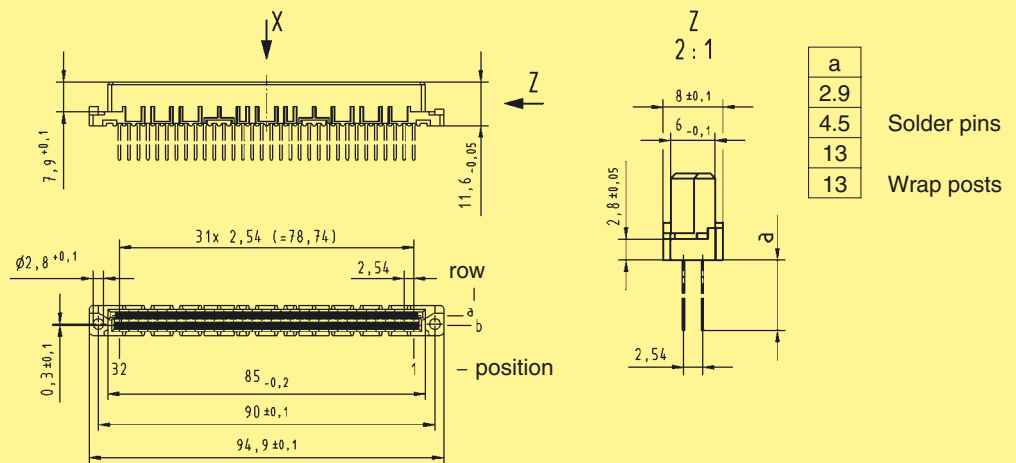

Panel cut out

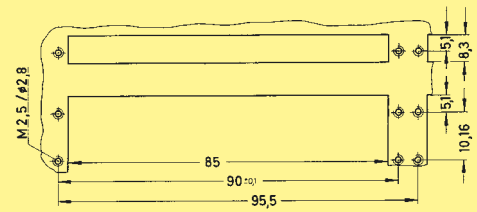

Board drillings

Mounting side

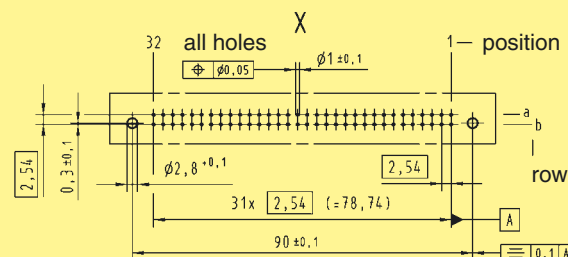

Identification strips for female connectors with wrap posts 09 02 000 9939

Dimensions in mm

DIN Signal to 2 A

Wrap posts selectively gold plated on request
 Other contact arrangements on request
^{b)} Connectors with snap-in clips see chapter 00
^{c)} Connectors with coding see page 01.44

Number of contacts

64

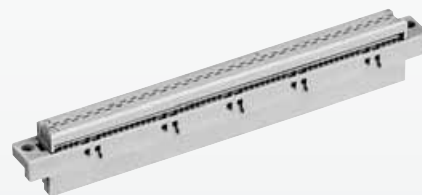

Female connectors

DIN Signal to 2 A

Identification	Number of contacts	Part No.	Drawing	Dimensions in mm
Female connector for insulation displacement	64	Performance level 2 ¹⁾ 09 02 264 6828 Performance level 3 ¹⁾ 09 02 264 7828	<p>Cable 1 to contact 1 b Contact arrangement View from termination side</p>	
Panel cut out				
Flat cable AWG 28/7 grey 50.00 m grey 150.00 m colour coded 30.48 m twisted pair ¹⁾ 30.48 m	64	09 18 064 7001 09 18 064 7004 09 18 064 7005 09 18 064 7006	<p>1) Termination area spacing = 508 mm</p> <p>Important: always store reels vertically</p> <p>Wire (tinned) Cu Gauge AWG 28/7 0.089 mm² Insulation material as per UL style PVC</p>	
Round flat cable ²⁾ with screening 30 m screening 150 m without screening 30 m screening 150 m	64	09 18 064 7007 09 18 064 7010 09 18 064 7008 09 18 064 7011	<p>2) Termination area spacing = 100 mm</p>	
Bench press		09 99 000 0114		
Base plate		09 99 000 0150		
Cable cutter		09 99 000 0116		
Spare parts				
Blade		09 99 000 0179		
Cutting plate		09 99 000 0180		

Number of contacts

max. 64

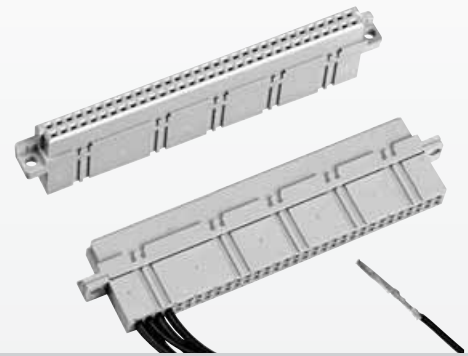

Female connectors

DIN Signal to 2 A

Identification	Number of contacts	Part No.	Drawing	Dimensions in mm
Female connector for crimp contacts Order contacts separately	64	09 02 064 3214	<p>Shell housing 09 02 064 0501 / 09 02 064 0502 see chapter 20</p>	

Identification	Part No.	Performance levels according to IEC 60 603-2. Explanation chapter 00	
		2	1
Female crimp contacts BC			
Bandoliered contacts (approx. 5,000 pieces)	09 02 000 6484		09 02 000 6474
Bandoliered contacts (approx. 500 pieces)	09 02 000 8434		09 02 000 8444
Individual contacts ¹⁾	09 02 000 8484		09 02 000 8474
	Wire gauge mm ² AWG Insulation ø mm 0.09 - 0.5 28 - 20 0.7 - 1.5		<p>Bandoliered contacts</p> <p>Individual contacts</p>
	3.5 + 0.5 mm of insulation is stripped Insertion, removal and crimping tools see chapter 30		

¹⁾ Packaging unit 1,000 pieces

DIN 41 612 · complementary type 2B



Number of contacts

32, 16



Male connectors

DIN Signal to 2 A

Identification	Number of contacts	Contact arrangement	Part No.	Performance levels according to IEC 60 603-2. Explanation chapter 00	
				3	2
Male connector with angled solder pins	32		09 22 132 7921	09 22 132 6921 09 22 332 6921 ^{b)}	09 22 132 2921
	16			09 22 116 6921	
	16		09 22 116 7931	09 22 116 6931	
	30 + 2 [▲]			09 22 132 6951	
Male connector with straight solder pins	32		09 22 132 7922	09 22 132 6922	09 22 132 2922

Dimensions

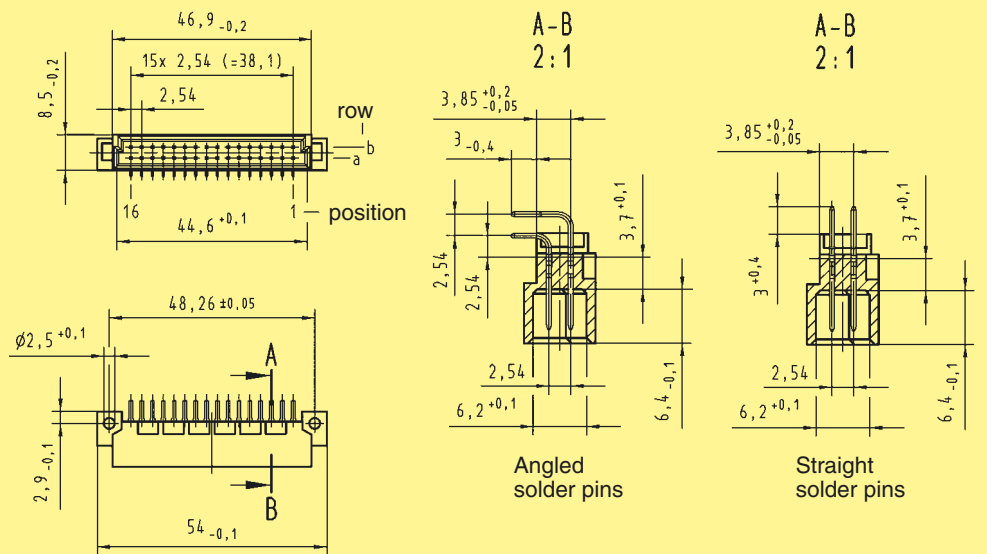

Board drillings

Mounting side

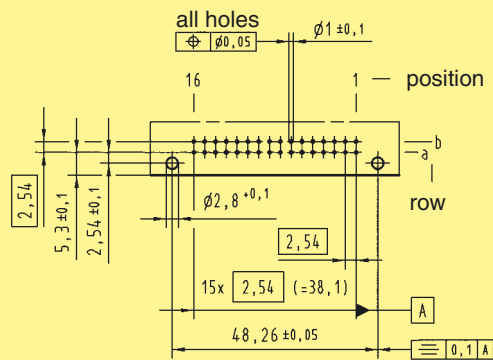

Dimensions in mm

01
16

▲ Male connectors with 2 leading contacts [(0.8 mm) pos. a1 and a16]. Lagging pins row b on request.

Other contact arrangements on request

^{b)} Connectors with snap-in clips see chapter 00

Number of contacts

32

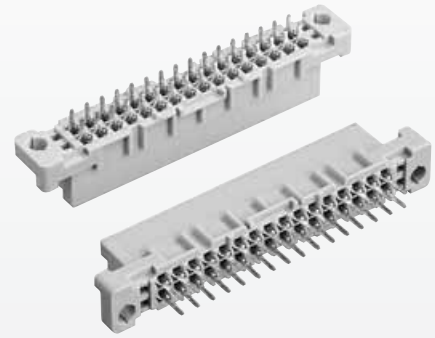

Female connectors

Identification	Number of contacts	Contact arrangement	Part No.	Performance levels according to IEC 60 603-2. Explanation chapter 00		
				3	2	1
Female connector with solder pins 2.9 mm	32		Performance level 3 on request	09 22 232 6824	Performance level 1 on request	
Female connector with solder pins 4.5 mm	32			09 22 232 6825		
Female connector with solder pins 13 mm	32			09 22 232 6421		
Female connector with wrap posts 13 mm	32			09 22 232 6821		

DIN Signal to 2 A

Female connector with press-in pins

Part Nos. and variants see chapter 04

Dimensions

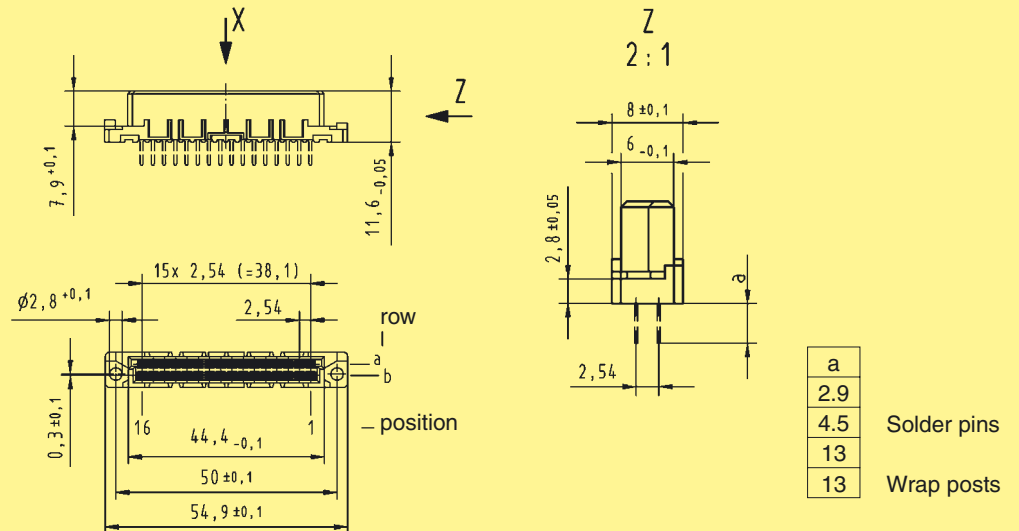

Board drillings
Mounting side

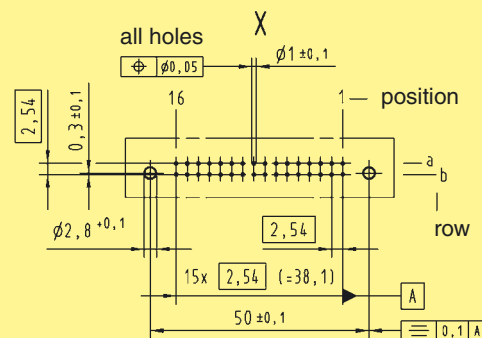

Dimensions in mm

Other contact arrangements on request
 b) Connectors with snap-in clips see chapter 00

Number of contacts

96, 64, 32

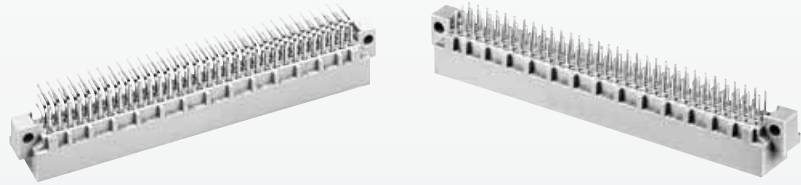

Male connectors

Identification	Number of contacts	Contact arrangement	Part No.	Performance levels according to IEC 60 603-2. Explanation chapter 00		
				3	2	1
Male connector with angled solder pins	96		09 03 196 7921 09 03 396 7921 ^{b)}	09 03 196 6921 09 03 396 6921 ^{b)} 09 03 696 6921 ^{c)}	09 03 196 2921 09 03 396 2921 ^{b)} 09 03 696 2921 ^{c)}	
	64		09 03 164 7921 09 03 364 7921 ^{b)}	09 03 164 6921 09 03 364 6921 ^{b)} 09 03 664 6921 ^{c)}	09 03 164 2921 09 03 364 2921 ^{b)} 09 03 664 2921 ^{c)}	
	32		09 03 132 7921 09 03 332 7921 ^{b)}	09 03 132 6921 09 03 332 6921 ^{b)}	09 03 132 2921 09 03 332 2921 ^{b)}	
	94 + 2 [▲]		09 03 196 7951	09 03 196 6951 09 03 396 6951 ^{b)}	09 03 196 2951	
	62 + 2 [▲]		09 03 164 7951	09 03 164 6951	09 03 164 2951	
Male connector with straight solder pins	96		09 03 196 7922	09 03 196 6922	09 03 196 2922	
	64		09 03 164 7922	09 03 164 6922	09 03 164 2922	

Dimensions

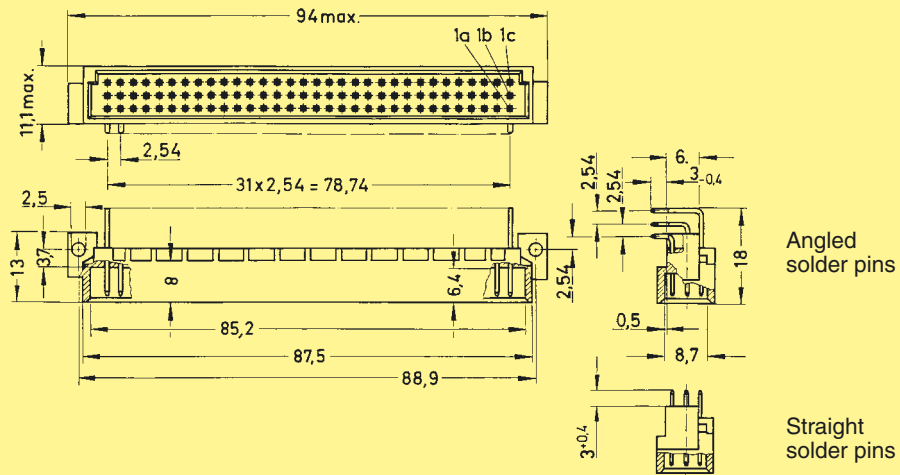

Board drillings

Mounting side

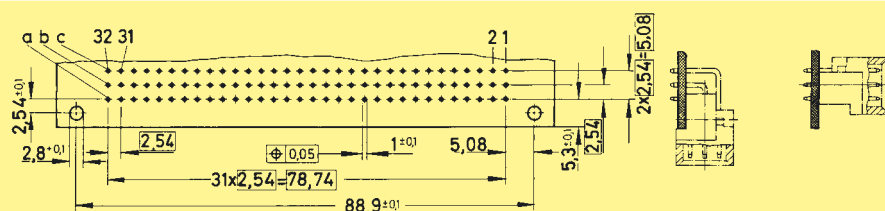

Dimensions in mm

[▲] Male connectors with 2 leading contacts [(0.8 mm) pos. a1 and a32]. Lagging pins row b on request.

High temperature connectors see chapter 05

^{b)} Connectors with snap-in clips see chapter 00

^{c)} Connectors with coding see page 01.44

Number of contacts

max. 96

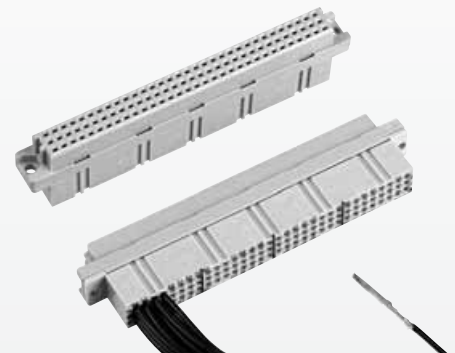

Female connectors

DIN Signal to 2 A

Identification	Number of contacts	Part No.	Drawing	Dimensions in mm
<p>Female connector for crimp contacts</p> <p>Order contacts separately</p>	96	<p>09 03 096 3214</p> <p>09 03 596 3214^{c)}</p>	<p>85, 84, 8,5, 11,6, 2,9^{+0,5}, 10, 90^{+0,1}, 2,8^{+0,1}, 1c 1b 1a, 5,1, 10,6^{+0,2}, 2,54, 31 x 2,54 = 78,74, 95^{-0,4}</p> <p>2 x 2,54 = 5,08</p> <p>View from termination side</p> <p>32 31 30 29 28 27 26 25 24 23 22 21 20 19 18 17 16 15 14 13 12 11 10 9 8 7 6 5 4 3 2 1</p>	<p>Shell housing 09 03 096 0501 see chapter 20</p>

Identification	Part No.	Performance levels according to IEC 60 603-2.	Explanation chapter
		2	1
<p>Female crimp contacts BC</p>			
<p>Bandoliered contacts (approx. 5,000 pieces)</p>	09 02 000 6484		09 02 000 6474
<p>Bandoliered contacts (approx. 500 pieces)</p>	09 02 000 8434		09 02 000 8444
<p>Individual contacts¹⁾</p>	09 02 000 8484		09 02 000 8474
	<p>Wire gauge mm²</p> <p>0.09 - 0.5</p>	<p>AWG</p> <p>28 - 20</p>	<p>Insulation ø mm</p> <p>0.7 - 1.5</p>
			<p>Bandoliered contacts</p> <p>Individual contacts</p>
	<p>3.5 + 0.5 mm of insulation is stripped from the wires to be crimped</p> <p>Insertion, removal and crimping tools see chapter 30</p>		

^{c)} Connectors with coding see page 01.44

¹⁾ Packaging unit 1,000 pieces

Number of contacts

96, 64, 32



Female connectors

Identification	Number of contacts	Contact arrangement	Part No.	Performance levels according to IEC 60 603-2. Explanation chapter 00	3	2	1
Female connector with kinked solder pins ¹⁾ 2.9 mm	96		09 03 296 7855			09 03 296 6855	09 03 296 2855
	64		09 03 264 7855			09 03 264 6855	09 03 264 2855
	32		09 03 232 7855			09 03 232 6855	09 03 232 2855
Female connector with kinked solder pins ¹⁾ 4.5 mm	96		09 03 296 7845			09 03 296 6845	09 03 296 2845
	64		09 03 264 7845			09 03 264 6845	09 03 264 2845
	32		09 03 232 7845			09 03 232 6845	09 03 232 2845

Dimensions

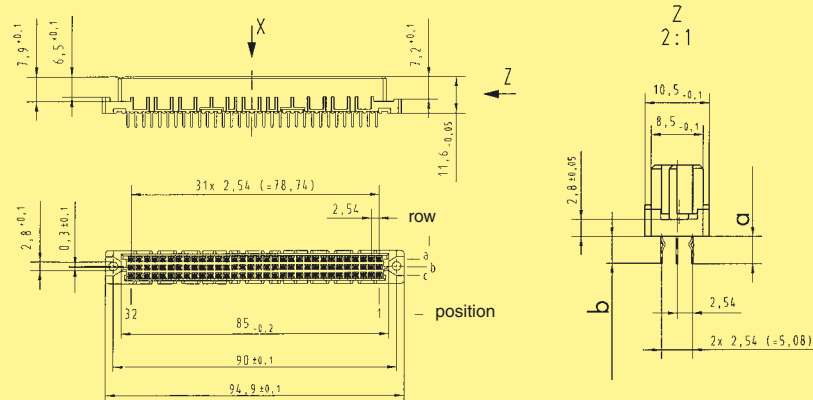

$b \triangleq$ Length of kinked pins

a	b
2.9	2.75
4.5	4.35

Solder pins

Board drillings

Mounting side

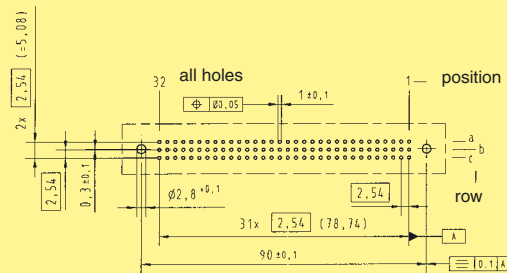

Dimensions in mm

¹⁾ Kinked pins for fixing the connector onto the pcb see chapter 00

Number of contacts

96, 64, 32

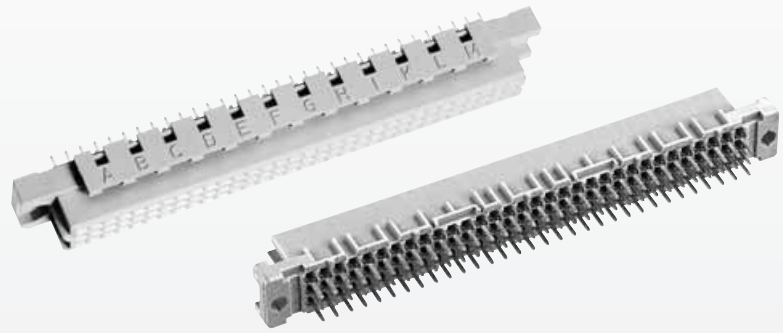

Female connectors

DIN Signal to 2 A

Identification	Number of contacts	Contact arrangement	Part No.	Performance levels according to IEC 60 603-2. Explanation chapter 00		
				3	2	1
Female connector with solder pins 2.9 mm	96		09 03 296 7824	09 03 296 6824 09 03 496 6824 ^{b)} 09 03 796 6824 ^{c)}	09 03 296 2824 09 03 496 2824 ^{b)}	
	64		09 03 264 7824	09 03 264 6824 09 03 464 6824 ^{b)} 09 03 764 6824 ^{c)}	09 03 264 2824 09 03 464 2824 ^{b)}	
	32		09 03 232 7824	09 03 232 6824	09 03 232 2824	
Female connector with solder pins 4.5 mm	96		09 03 296 7825 09 03 496 7825 ^{b)}	09 03 296 6825 09 03 496 6825 ^{b)} 09 03 796 6825 ^{c)}	09 03 296 2825	
	64		09 03 264 7825 09 03 464 7825 ^{b)}	09 03 264 6825 09 03 464 6825 ^{b)} 09 03 764 6825 ^{c)}	09 03 264 2825	
	32		09 03 232 7825	09 03 232 6825	09 03 232 2825	
Female connector with solder pins 13 mm	96			09 03 296 6421 09 03 796 6421 ^{c)}		
	64			09 03 264 6421 09 03 764 6421 ^{c)}		
	32			09 03 232 6421 09 03 732 6421 ^{c)}		

Dimensions

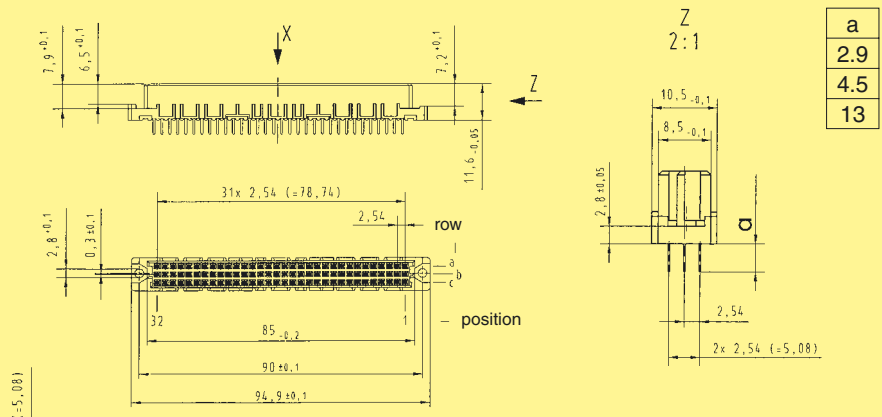

a	Solder pins
2.9	
4.5	
13	

Board drillings
Mounting side

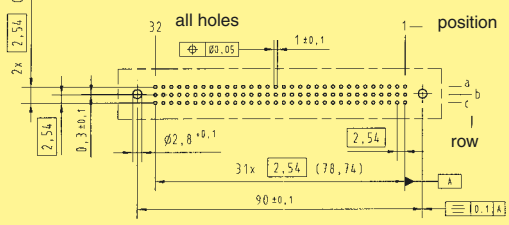

Dimensions in mm

^{b)} Connectors with snap-in clips see chapter 00
^{c)} Connectors with coding see page 01.44

Number of contacts

96, 64, 32

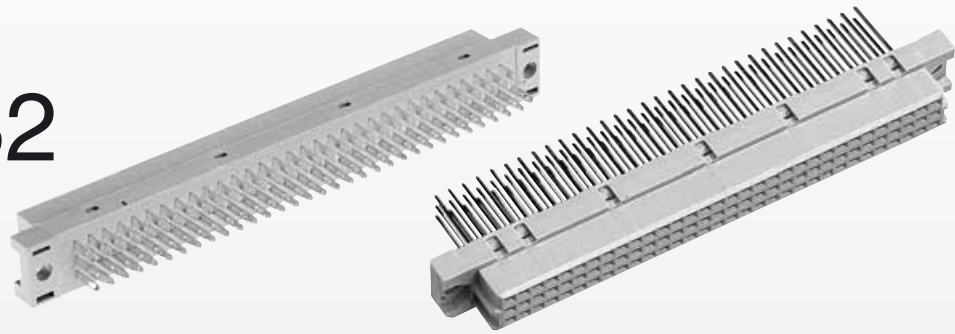

Female connectors

DIN Signal to 2 A

Identification	Number of contacts	Contact arrangement	Part No.	Performance levels according to IEC 60 603-2. Explanation chapter 00		
				3	2	1
Female connector with wrap posts 13 mm	96		Performance level 3 on request	09 03 296 6821	Performance level 1 on request	
	64			09 03 796 6821 ^{o)} 09 03 296 6878 ¹⁾		
Female connector with solder lugs a + c 5.2 mm b 7.7 mm	96			09 03 264 6821		
	64			09 03 264 6878 ¹⁾		
Female connector with press-in pins	Part Nos. and variants see chapter 04					

Dimensions

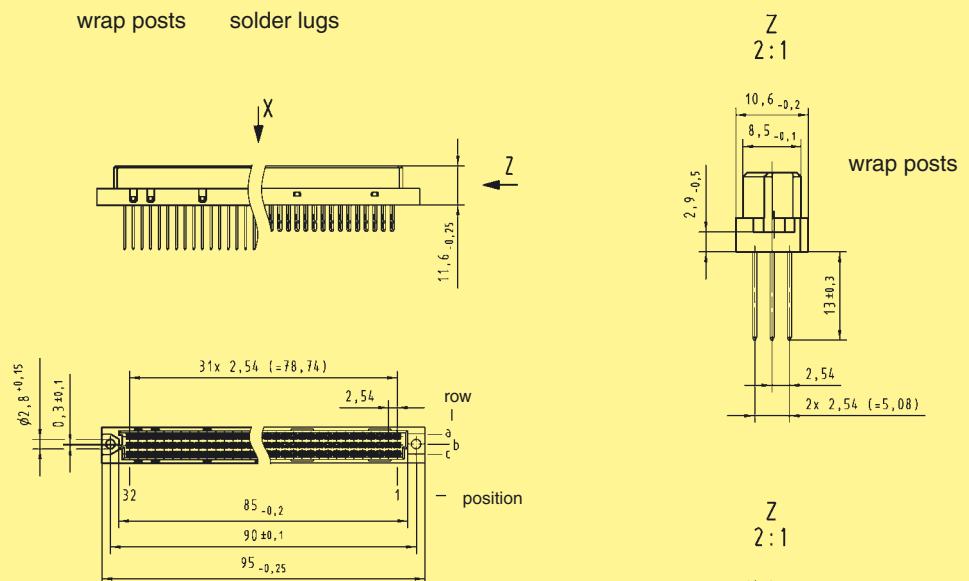

Panel cut out

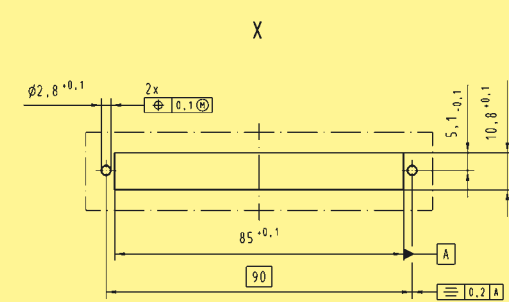

Identification strips for female connectors with wrap posts 09 03 000 9939

Dimensions in mm

¹⁾ Wrap posts for interfacing, selectively gold-plated (performance level 3)
^{o)} Connectors with coding see page 01.44

Number of contacts

64

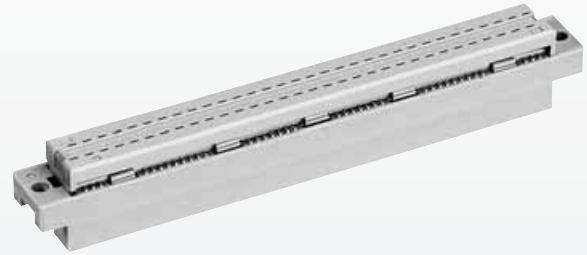

Female connectors

DIN Signal to 2 A

Identification	Number of contacts	Part No.	Drawing	Dimensions in mm
<p>Female connector for insulation displacement</p>	64	<p>Performance level 2¹⁾ 09 03 264 6828 09 03 764 6828^{c)}</p> <p>Performance level 3¹⁾ 09 03 264 7828</p>	<p>Cable 1 to contact 1 c Contact arrangement View from termination side</p>	
Panel cut out				Mateable with 3 row male connector type C, no female contacts in the middle row
<p>Flat cable</p> <p>AWG 28/7</p> <p>grey 50.00 m</p> <p>grey 150.00 m</p> <p>colour coded 30.48 m</p> <p>twisted pair¹⁾ 30.48 m</p>	64 64 64 64	09 18 064 7001 09 18 064 7004 09 18 064 7005 09 18 064 7006	<p>1) Termination area spacing = 508 mm</p> <p>Important: always store reels vertically</p> <p>Wire (tinned) Cu Gauge AWG 28/7 0.089 mm² Insulation material as per UL style PVC</p>	
<p>Round flat cable²⁾</p> <p>with screening 30 m</p> <p>with screening 150 m</p> <p>without screening 30 m</p> <p>without screening 150 m</p>	64 64 64 64	09 18 064 7007 09 18 064 7010 09 18 064 7008 09 18 064 7011	<p>2) Termination area spacing = 100 mm</p>	
Bench press		09 99 000 0114		
Base plate		09 99 000 0150		
Cable cutter		09 99 000 0116		
Spare parts				
Blade		09 99 000 0179		
Cutting plate		09 99 000 0180		



Further components and accessories for insulation displacement see interface catalogue, chapter 40

^{c)} Connectors with coding see page 01.44

¹⁾ acc. to IEC 60 603-2

Number of contacts

48, 32, 16

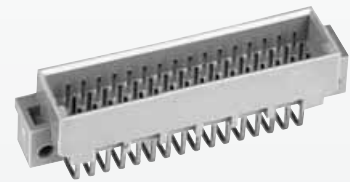

Male connectors

Identification	Number of contacts	Contact arrangement	Part No.	Performance levels according to IEC 60 603-2. Explanation chapter 00		
				3	2	1
Male connector with angled solder pins	48		09 23 148 7921 09 23 348 7921 ^{b)}	09 23 148 6921 09 23 348 6921 ^{b)}	09 23 148 2921	
	32		09 23 132 7921 09 23 332 7921 ^{b)}	09 23 132 6921 09 23 332 6921 ^{b)}	09 23 132 2921	
	16				09 23 116 2921	
	16		09 23 116 7931	09 23 116 6931 09 23 316 6931 ^{b)}	09 23 116 2931	
	46 + 2 [▲]		09 23 148 7951	09 23 148 6951 09 23 348 6951 ^{b)}	09 23 148 2951	
Male connector with straight solder pins	48		09 23 148 7922	09 23 148 6922	09 23 148 2922	
	32		09 23 132 7922	09 23 132 6922	09 23 132 2922	

Dimensions

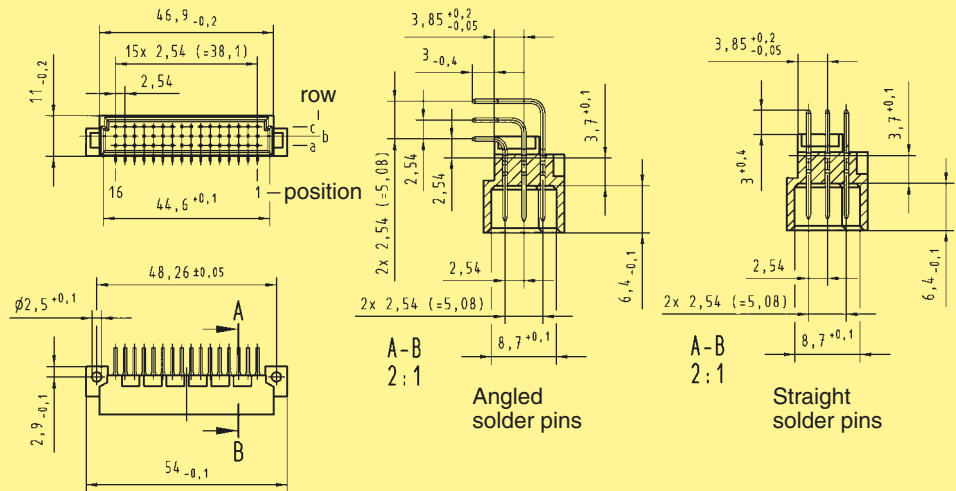

Board drillings

Mounting side

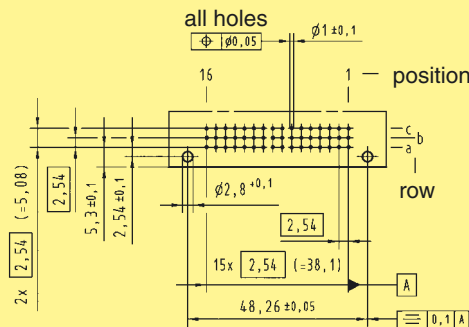

Dimensions in mm

[▲] Male connectors with 2 leading contacts [(0.8 mm) pos. a1 and a16]. Lagging pins row b on request.

Other contact arrangements on request

High temperature connector see chapter 05

^{b)} Connectors with snap-in clips see chapter 00

Number of contacts

48

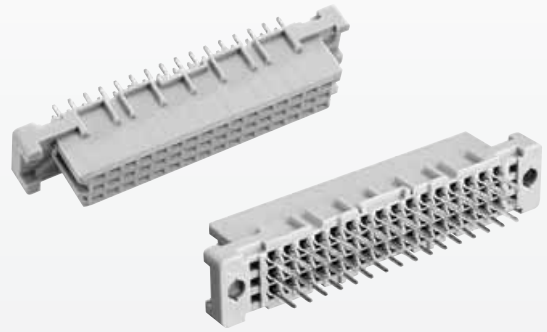

Female connectors

Identification	Number of contacts	Contact arrangement	Part No.	Performance levels according to IEC 60 603-2. Explanation chapter 00		
				3	2	1
Female connector with solder pins 2.9 mm	48		Performance level 3 on request	09 23 248 6824	Performance level 1 on request	
Female connector with solder pins 4.5 mm	48			09 23 248 6825		
Female connector with solder pins 13 mm	48			09 23 248 6421		
Female connector with wrap posts 13 mm	48			09 23 248 6821		

Female connector with press-in pins

Part Nos. and variants see chapter 04

Dimensions

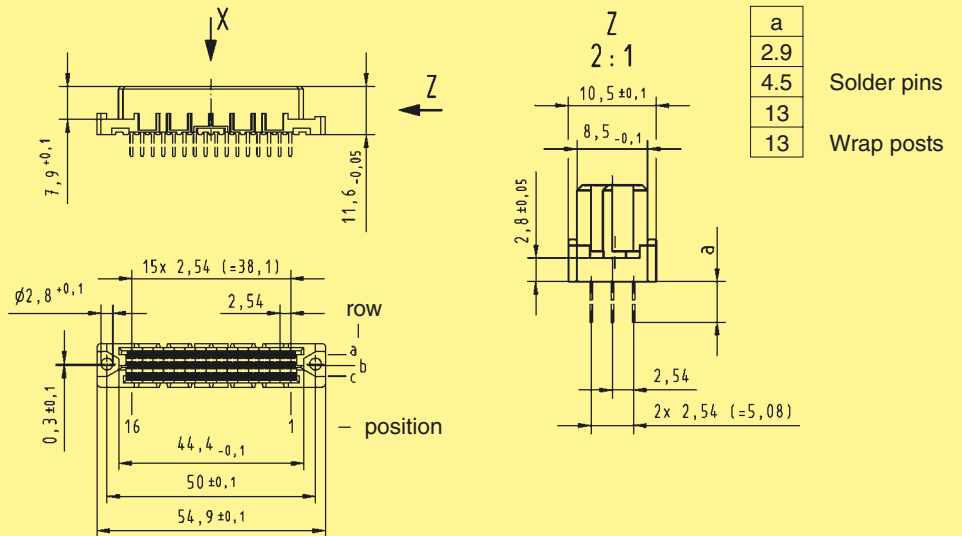

Board drillings

Mounting side

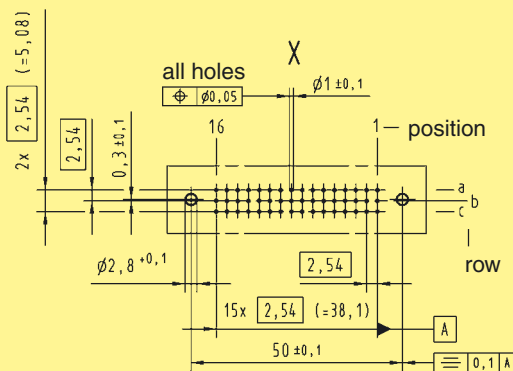

Dimensions in mm

Other contact arrangements on request

^{b)} Connectors with snap-in clips see chapter 00

Number of contacts

30



Male and female connectors

Identification	Number of contacts	Contact arrangement	Part No.	Performance levels according to IEC 60 603-2. Explanation chapter 00
				3 2 1
Male connector with angled solder pins	30		Performance level 3 on request	09 25 130 6921
Female connector with solder pins 2.9 mm	30			09 25 230 6824
Female connector with solder pins 4.5 mm	30			09 25 230 6825

Female connector with press-in pins

Part Nos. and variants see chapter 04

Dimensions

Male connectors

Female connectors

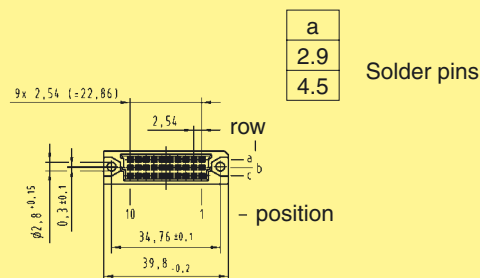
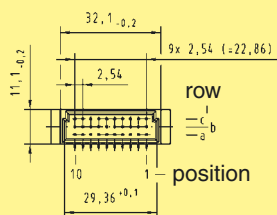
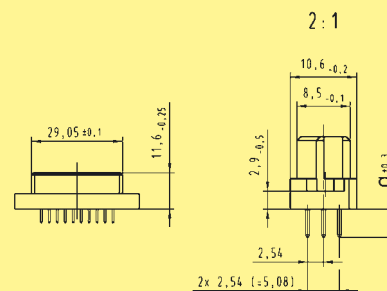
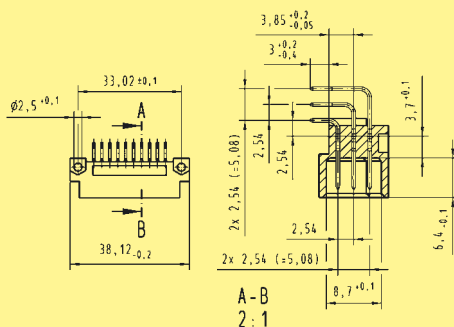

Board drillings

Mounting side

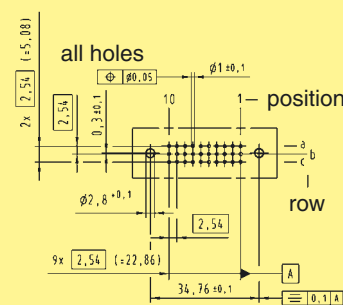
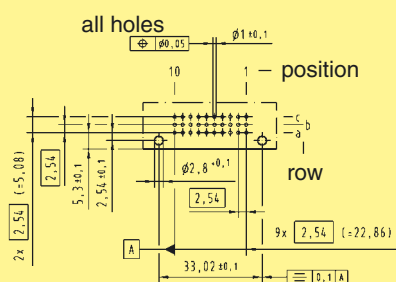

Dimensions in mm

Number of contacts

78+2, 60+4,
42+6, 24+8

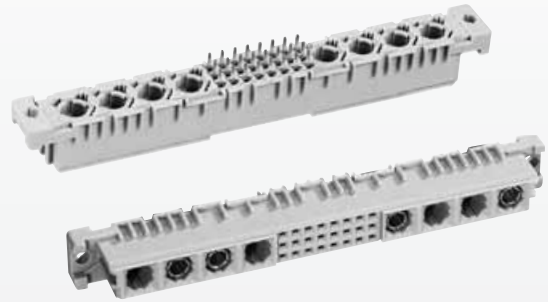

Female connectors

Identification	Number of contacts	Contact arrangement	Part No. 3	Performance levels according to IEC 60 603-2. Explanation chapter 00	
				2	1
Female connector with solder pins 2.9 mm (without special contacts)*	78 + 2		Performance level 3 on request	09 03 278 6864	Performance level 1 on request
	60 + 4			09 03 260 6864	
	42 + 6			09 03 242 6864	
	24 + 8			09 03 224 6864	
Female connector with solder pins 4.5 mm (without special contacts)*	78 + 2		Performance level 3 on request	09 03 278 6865	Performance level 1 on request
	60 + 4			09 03 260 6865	
	42 + 6			09 03 242 6865	
	24 + 8			09 03 224 6865	

Female connector with press-in pins

Part Nos. and variants see chapter 04

Dimensions

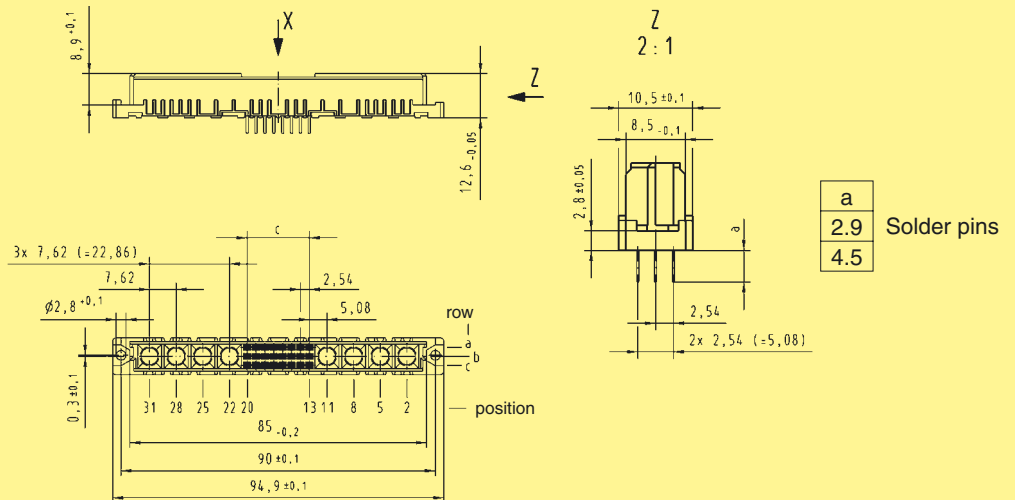

Order high current, high voltage, coaxial and fibre optic contacts separately, see pages 01.30 and 01.31

Board drillings

Mounting side

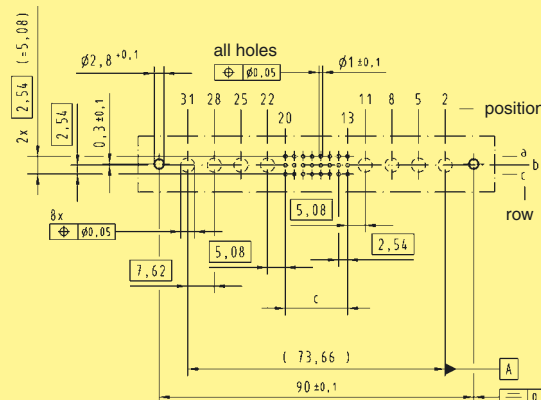

Type	c
78 + 2	25 x 2.54 = 63.5
60 + 4	19 x 2.54 = 48.26
42 + 6	13 x 2.54 = 33.02
24 + 8	7 x 2.54 = 17.78

Dimensions in mm

* Pre-loaded with special contacts on request

Number of contacts

78+2, 60+4, 42+6, 24+8



Male connectors

Identification	Number of contacts	Contact arrangement	Part No.	Performance levels according to IEC 60 603-2. Explanation chapter 00	
			3	2	1
Male connector with angled solder pins (without special contacts)*	78 + 2		09 03 178 7901	09 03 178 6901	09 03 178 2901 09 03 378 2901 ^{b)}
	60 + 4		09 03 160 7901	09 03 160 6901	09 03 160 2901
	42 + 6		09 03 142 7901	09 03 142 6901	09 03 142 2901
	24 + 8		09 03 124 7901	09 03 124 6901	09 03 124 2901

Dimensions

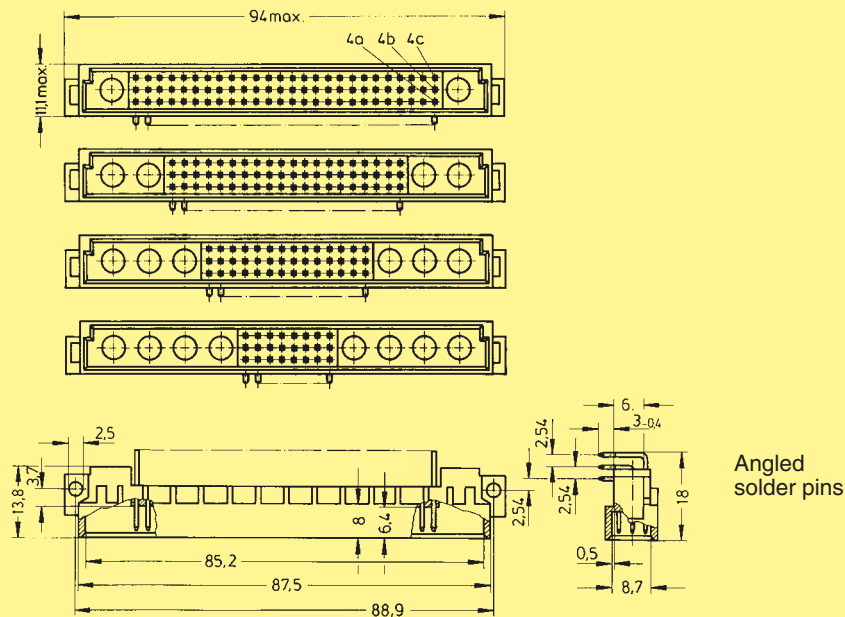

Order high current, high voltage, coaxial and fibre optic contacts separately, see pages 01.30 and 01.31

Board drillings

Mounting side

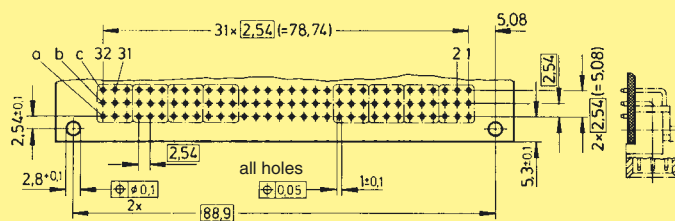

△ Board drillings depend on type and special contact loading

Dimensions in mm

DIN Signal to 2 A

* Pre-loaded with special contacts on request

^{b)} Connectors with snap-in clips see chapter 00

Number of contacts

78+2, 60+4,
42+6, 24+8

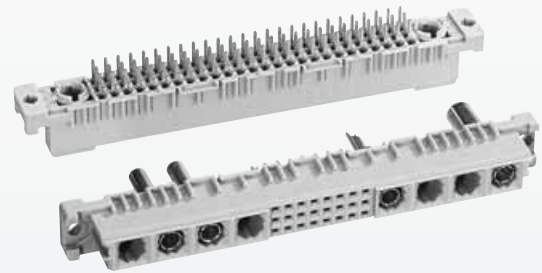

Female connectors

Identification	Number of contacts	Contact arrangement	Part No.	Performance levels according to IEC 60 603-2. Explanation chapter 00		
				3	2	1
Female connector with solder pins 2.9 mm (without special contacts)	78 + 2		Performance level 3 on request	09 03 278 6804	Performance level 1 on request	
	60 + 4			09 03 260 6804		
	42 + 6			09 03 242 6804		
	24 + 8			09 03 224 6804		
Female connector with solder pins 4.5 mm (without special contacts)	78 + 2			09 03 278 6805		
	60 + 4			09 03 260 6805		
	42 + 6			09 03 242 6805		
	24 + 8			09 03 224 6805		

Female connector with press-in pins

Part Nos. and variants see chapter 04

Dimensions

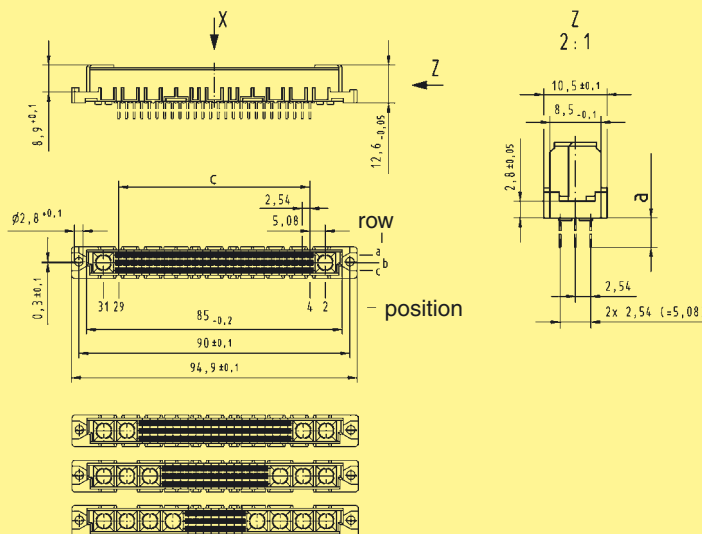

Order high current, high voltage, coaxial and fibre optic contacts separately, see pages 01.30 and 01.31

Board drillings

Mounting side

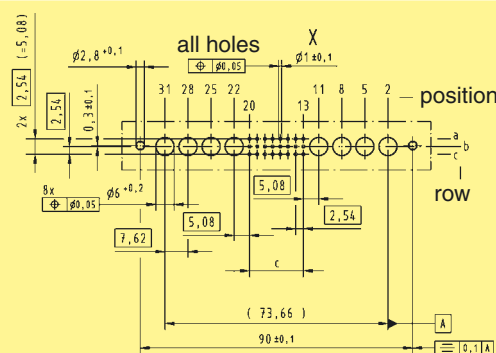

Type	c
78 + 2	25 x 2.54 = 63.5
60 + 4	19 x 2.54 = 48.26
42 + 6	13 x 2.54 = 33.02
24 + 8	7 x 2.54 = 17.78

Dimensions in mm

Other contact arrangements on request

DIN 41 612 · Special contacts type M



High current contacts
High voltage contacts

DIN Signal
to 2 A

Identification	Part No. Performance level 2	Drawing	Dimensions in mm																				
High current male contacts for male connectors¹⁾																							
I for straight crimp termination 10 A 20 A 40 A	09 03 000 6113 09 03 000 6114 09 03 000 6115		<table border="1"> <thead> <tr> <th></th> <th>ø A</th> <th>ø B</th> <th>wire gauge [mm²]</th> <th>AWG</th> </tr> </thead> <tbody> <tr> <td>10 A</td> <td>1.85</td> <td>2.55</td> <td>1.5</td> <td>16</td> </tr> <tr> <td>20 A</td> <td>2.80</td> <td>3.70</td> <td>4</td> <td>12</td> </tr> <tr> <td>40 A</td> <td>4.40</td> <td>5.60</td> <td>10</td> <td>8</td> </tr> </tbody> </table>		ø A	ø B	wire gauge [mm ²]	AWG	10 A	1.85	2.55	1.5	16	20 A	2.80	3.70	4	12	40 A	4.40	5.60	10	8
	ø A	ø B	wire gauge [mm ²]	AWG																			
10 A	1.85	2.55	1.5	16																			
20 A	2.80	3.70	4	12																			
40 A	4.40	5.60	10	8																			
II for straight solder termination 10 A 20 A 40 A Leading contact 10 A 20 A 40 A	09 03 000 6101 09 03 000 6102 09 03 000 6103 09 03 000 6111 09 03 000 6122 09 03 000 6133		<table border="1"> <thead> <tr> <th></th> <th>ø</th> </tr> </thead> <tbody> <tr> <td>10 A</td> <td>1.7</td> </tr> <tr> <td>20 A</td> <td>2.8</td> </tr> <tr> <td>40 A</td> <td>4.8</td> </tr> </tbody> </table>		ø	10 A	1.7	20 A	2.8	40 A	4.8												
	ø																						
10 A	1.7																						
20 A	2.8																						
40 A	4.8																						
for angled pcb termination max. 40 A* Leading contact max. 40 A* * depending on the pcb design	09 03 000 6104 09 03 000 6134		<table border="1"> <thead> <tr> <th></th> <th>x</th> </tr> </thead> <tbody> <tr> <td>... 6104</td> <td>17.7</td> </tr> <tr> <td>... 6134</td> <td>18.4</td> </tr> </tbody> </table>		x	... 6104	17.7	... 6134	18.4														
	x																						
... 6104	17.7																						
... 6134	18.4																						
High current female contacts for female connectors²⁾																							
III for straight crimp termination 10 A 20 A 40 A	09 03 000 6213 09 03 000 6214 09 03 000 6215		<table border="1"> <thead> <tr> <th></th> <th>ø A</th> <th>ø B</th> <th>wire gauge [mm²]</th> <th>AWG</th> </tr> </thead> <tbody> <tr> <td>10 A</td> <td>1.85</td> <td>2.55</td> <td>1.5</td> <td>16</td> </tr> <tr> <td>20 A</td> <td>2.80</td> <td>3.70</td> <td>4</td> <td>12</td> </tr> <tr> <td>40 A</td> <td>4.40</td> <td>5.60</td> <td>10</td> <td>8</td> </tr> </tbody> </table>		ø A	ø B	wire gauge [mm ²]	AWG	10 A	1.85	2.55	1.5	16	20 A	2.80	3.70	4	12	40 A	4.40	5.60	10	8
	ø A	ø B	wire gauge [mm ²]	AWG																			
10 A	1.85	2.55	1.5	16																			
20 A	2.80	3.70	4	12																			
40 A	4.40	5.60	10	8																			
IV for straight solder termination 10 A 20 A 40 A	09 03 000 6201 09 03 000 6202 09 03 000 6203		<table border="1"> <thead> <tr> <th></th> <th>ø</th> </tr> </thead> <tbody> <tr> <td>10 A</td> <td>1.7</td> </tr> <tr> <td>20 A</td> <td>2.8</td> </tr> <tr> <td>40 A</td> <td>4.8</td> </tr> </tbody> </table>		ø	10 A	1.7	20 A	2.8	40 A	4.8												
	ø																						
10 A	1.7																						
20 A	2.8																						
40 A	4.8																						
V for type M-flat for press-in termination 40 A for solder termination 40 A	09 03 000 6250 09 03 000 6225																						
High voltage male contact for male connectors³⁾																							
VI for straight solder termination 2.8 kV	09 03 000 6140		Wire gauge max. 0.5 mm ²																				
High voltage female contact for female connectors³⁾																							
VII for straight solder termination 2.8 kV	09 03 000 6240		Wire gauge max. 0.5 mm ²																				
Crimping tool for high current contacts	09 99 000 0196																						

²⁾ Contact resistance max. 1.5 mΩ

³⁾ Contact resistance internal wire max. 3 mΩ

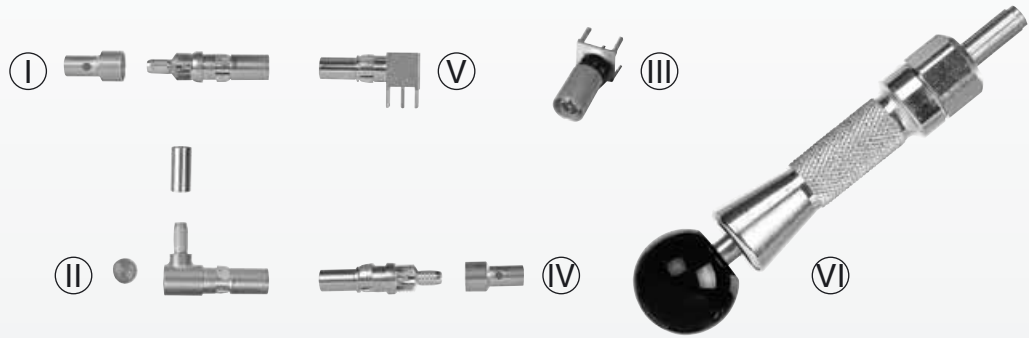

Coaxial contacts

DIN Signal to 2 A

Identification	Part No. Performance level 2	Drawing	Dimensions in mm
Male coaxial contacts for female connectors (I) for straight solder and/or crimp termination (II) for angled solder and/or crimp termination (III) for straight pcb termination for type M-flat	09 03 000 6160 09 03 000 6181* 09 03 000 6161 09 03 000 6182		Assembly instruction for contacts (I) and (III)
Female coaxial contacts for male connectors (IV) for straight solder and/or crimp termination (V) angled for pcb termination	without knurled area 09 03 000 6260 09 03 000 6281* with knurled area 09 03 000 6274 09 03 000 6262 09 03 000 6269*	<p>1) Solder pins for hole $\varnothing 1 \pm 0.1$ mm</p>	Assembly instruction for contacts (II)
Crimping tool for coaxial contacts	09 99 000 0194		
Removal tool incl. removal jacket (VI) for contact replacement	09 99 000 0174		
Replacement removal jacket	09 99 000 0243		

Electrical characteristics of 50 Ω coaxial contacts and wires

Impedance	50 Ω
Max. working frequency	2 up to 10 GHz
VSWR-value	1.07 + 0.02 f [GHz]
Proof voltage	750 V / 50 Hz
Working voltage	250 V / 50 Hz
Insulation resistance	≥ 1 GΩ
Contact resistance	– Center contact: 10 mΩ – Outer contact: 3 mΩ
Contact current max.	1.5 A
Admissible power (depends on: frequency, application, VSWR, environmental characteristics)	Data on request
75 Ohm versions	Data on request

Cable group 2 flexible wires	Shell \varnothing	Screening \varnothing	Dielectric \varnothing	Internal wire \varnothing	Hexagonal crimp Spanner width
RG 174 A/U	2.5	2.0	1.5	0.48	3.25
RG 188 A/U	2.6	2.0	1.5	0.54	3.25
RG 316 U	2.5	2.0	1.5	0.54	3.25

* Coaxial contact 75 Ω
Fibre optic contacts on request

Number of contacts

96, 64

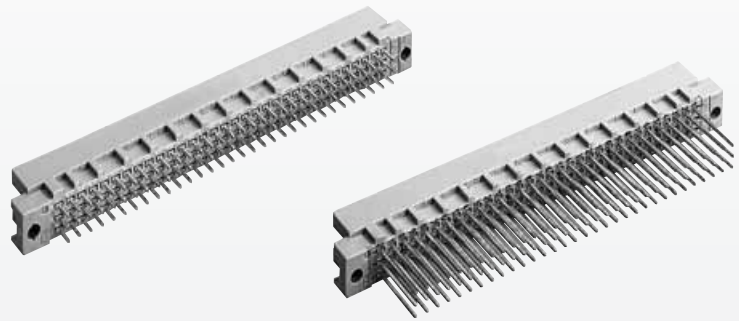

Male connectors

DIN Signal to 2 A

Identification	Number of contacts	Contact arrangement	Part No.	Performance levels according to IEC 60 603-2. Explanation chapter 00													
				3	2	1											
Male connector with solder pins 2.5 mm	96		09 73 196 7902	09 73 196 6902 09 73 396 6902 ^{b)}	09 73 196 2902												
	64		09 73 164 7902	09 73 164 6902 09 73 364 6902 ^{b)}	09 73 164 2902 09 73 364 2902 ^{b)}												
Male connector with solder pins 4.0 mm	96		09 73 196 7903	09 73 196 6903 09 73 396 6903 ^{b)} 09 73 196 6953	09 73 196 2903												
	94 + 2 [▲] 64		09 73 164 7903	09 73 164 6903 09 73 364 6903 ^{b)}	09 73 164 2903												
Male connector with solder pins 13 mm	96			09 73 196 6577	09 73 196 2577												
	64			09 73 164 6577													
Male connector with wrap posts 13 mm	96		09 73 196 7907	09 73 196 6907	09 73 196 2907												
	64		09 73 164 7907	09 73 164 6907	09 73 164 2907												
Male connector with press-in pins	Part Nos. and variants see chapter 04																
Dimensions	<table border="1" style="margin-top: 10px;"> <tr> <td>a</td> <td>b</td> <td rowspan="3">Solder pins</td> </tr> <tr> <td>2.5</td> <td>∅ 0.7</td> </tr> <tr> <td>4</td> <td>□ 0.6</td> </tr> <tr> <td>a</td> <td>b</td> <td rowspan="2">Wrap posts</td> </tr> <tr> <td>13</td> <td>□ 0.6</td> </tr> </table>					a	b	Solder pins	2.5	∅ 0.7	4	□ 0.6	a	b	Wrap posts	13	□ 0.6
a	b	Solder pins															
2.5	∅ 0.7																
4	□ 0.6																
a	b	Wrap posts															
13	□ 0.6																
Panel cut out	<div style="display: flex; justify-content: space-around; margin-top: 10px;"> <div style="text-align: center;"> <p>96</p> </div> <div style="text-align: center;"> <p>64</p> </div> <div style="text-align: center;"> <p>32</p> </div> </div> <p style="text-align: right;">Contact arrangement View from termination side</p>																
Board drillings Mounting side	<p style="text-align: right;">Dimensions in mm</p>																

▲ Male connectors with 2 leading contacts [(0.8 mm) pos. a1 and a32]

Other contact arrangements as well with lagging pins on request

^{b)} Connectors with snap-in clips see chapter 00

Number of contacts

96, 64, 32

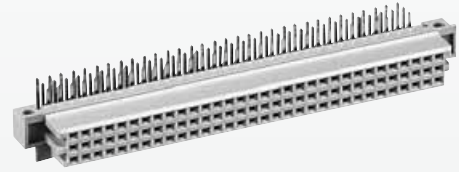

Female connectors

Identification	Number of contacts	Contact arrangement	Part No. Performance levels according to IEC 60 603-2. Explanation chapter 00		
			3	2	1
Female connector with angled solder pins	96		09 73 296 7801 09 73 496 7801 ^{b)}	09 73 296 6801 09 73 496 6801 ^{b)}	09 73 296 2801
	64		09 73 264 7801 09 73 464 7801 ^{b)}	09 73 264 6801 09 73 464 6801 ^{b)}	09 73 264 2801
	32		09 73 232 7801	09 73 232 6801	09 73 232 2801
	32		09 73 232 7811	09 73 232 6811	09 73 232 2811

Dimensions

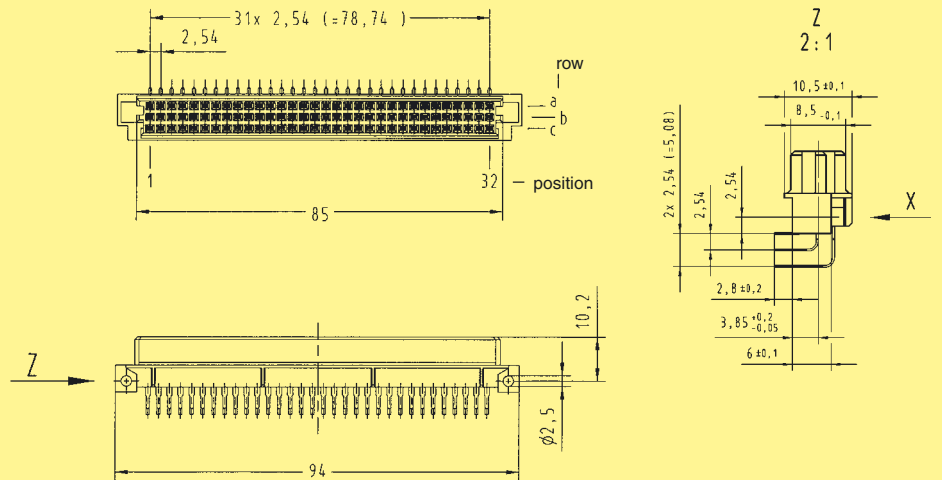

Board drillings

Mounting side

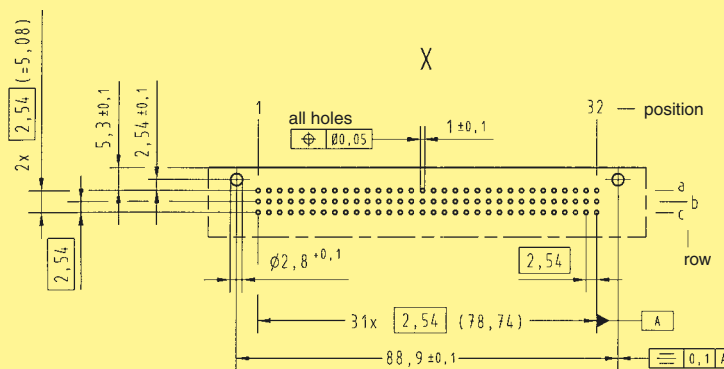

Dimensions in mm

DIN Signal to 2 A

Other contact arrangements on request
 High temperature connectors see chapter 05
^{b)} Connectors with snap-in clips see chapter 00

DIN 41 612 · complementary to type R (HE 11)



Number of contacts

96, 64

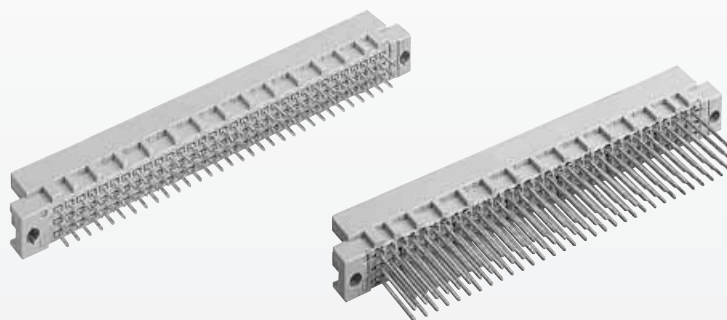

Male connectors

DIN Signal to 2 A

Identification Number of contacts Contact arrangement Part No. Performance levels according to IEC 60 603-2. Explanation chapter 00

Identification	Number of contacts	Contact arrangement	Part No.	Performance levels according to IEC 60 603-2. Explanation chapter 00		
				3	2 1	
Male connector with solder pins 2.5 mm	96		Performance level 3 on request	Performance level 3 on request	09 79 196 6902	
Male connector with solder pins 4.0 mm	96				09 79 196 6903 09 79 396 6903 ^{b)}	Performance level 1 on request
	64				09 79 164 6903 09 79 364 6903 ^{b)}	
Male connector with wrap posts 13 mm	96				09 79 196 6907	
	64				09 79 164 6907	

Dimensions

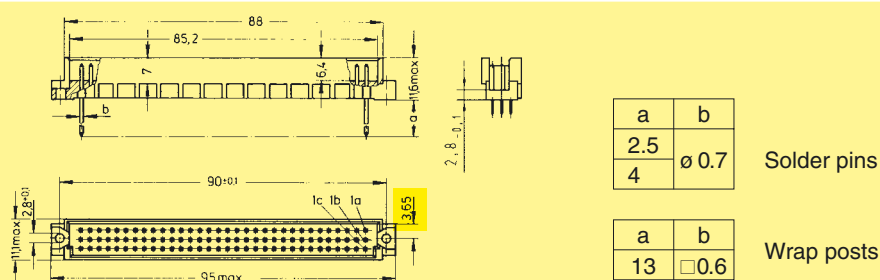

Panel cut out

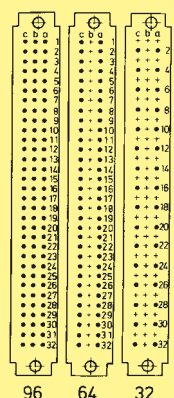
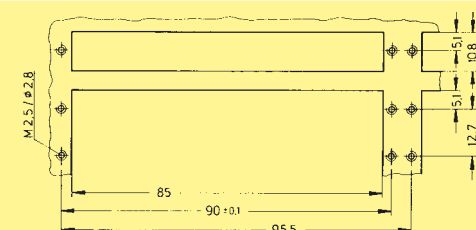

Contact arrangement
View from termination side

Board drillings Mounting side

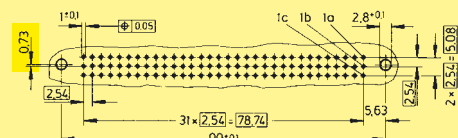

Dimensions in mm

Other contact arrangements on request

 = deviating dimensions from standard male connectors (see page 01.32)

^{b)} Connectors with snap-in clips see chapter 00

Number of contacts

96, 64

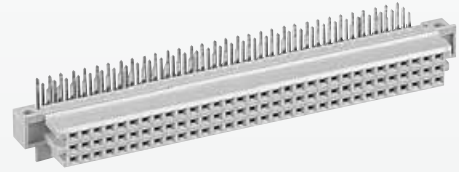

Female connectors

Identification	Number of contacts	Contact arrangement	Part No.			Performance levels according to IEC 60 603-2. Explanation chapter 00		
			3	2	1	3	2	1
Female connector with angled solder pins	96		09 79 296 7801	09 79 296 6801 09 79 496 6801 ^{b)}	Performance level 1 on request			
	64		09 79 264 7801	09 79 264 6801 09 79 464 6801 ^{b)}				

Dimensions

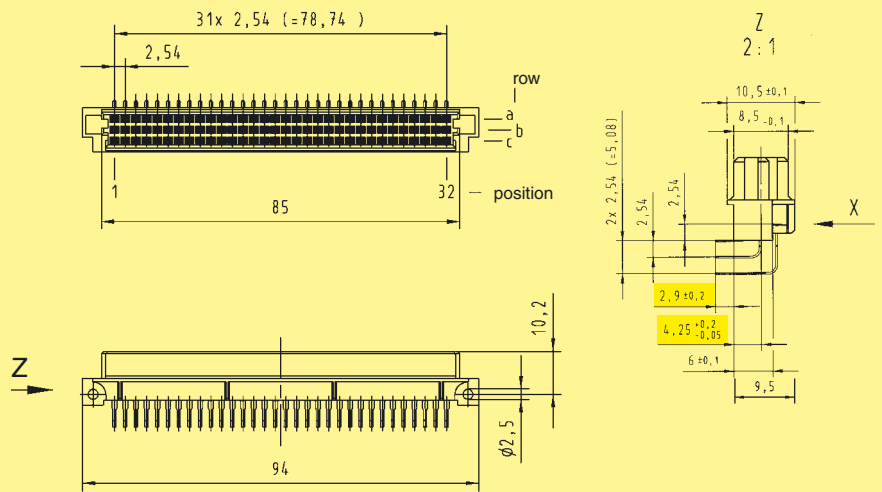

Board drillings

Mounting side

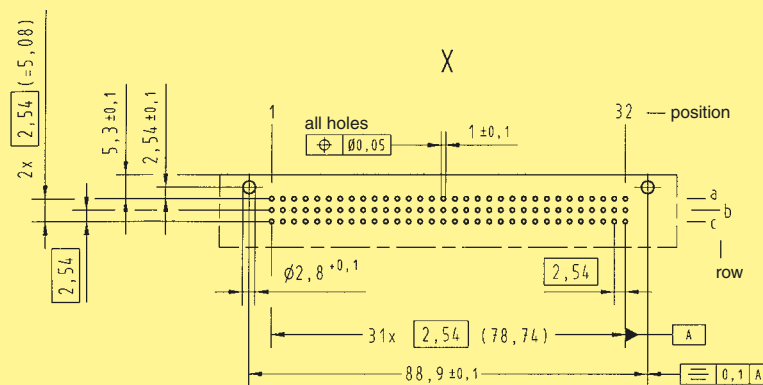

Dimensions in mm

Other contact arrangements on request

= deviating dimensions from standard female connectors (see page 01.33)

^{b)} Connectors with snap-in clips see chapter 00

Number of contacts

64

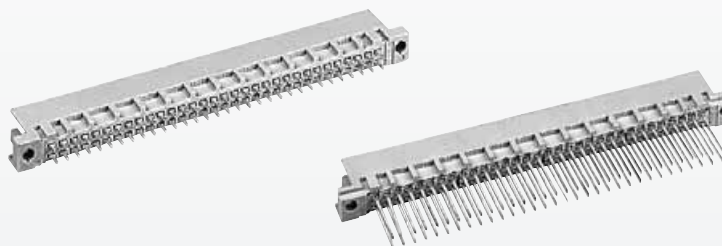

Male connectors

Identification	Number of contacts	Contact arrangement	Part No.	Performance levels according to IEC 60 603-2. Explanation chapter 00		
				3	2	1
Male connector with solder pins 2.5 mm	64		09 72 164 7902	09 72 164 6902 b) 09 72 364 6902 ^{b)}	Performance level 1 on request	
Male connector with solder pins 4.0 mm	64		09 72 164 7903	09 72 164 6903		
Male connector with solder pins 13 mm	64			09 72 164 6577		
Male connector with wrap posts 13 mm	64		09 72 164 7907	09 72 164 6907		
Male connector with wrap posts 17 mm	64			09 72 164 6909		

Male connector with press-in pins

Part Nos. and variants see chapter 04

Dimensions

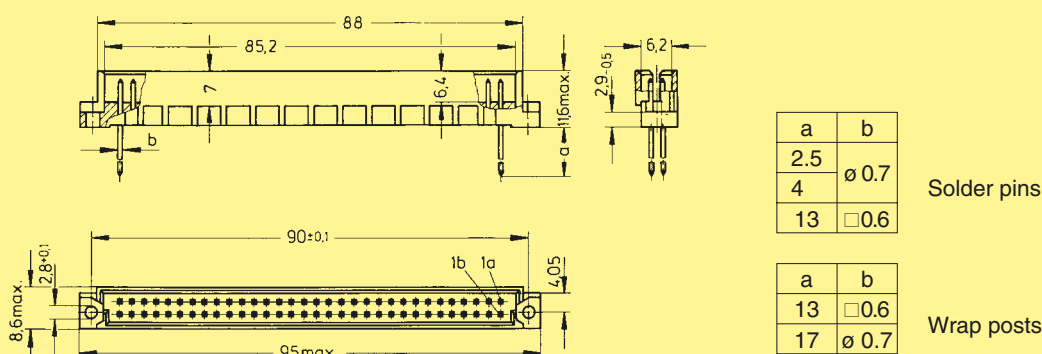

Panel cut out

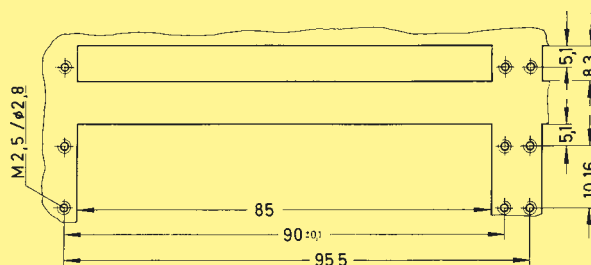

Board drillings
Mounting side

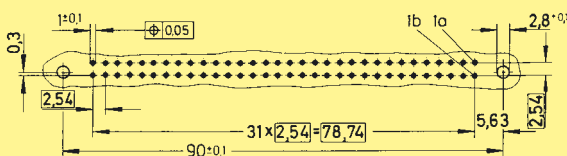

Dimensions in mm

Other contact arrangements as well with lagging/leading pins on request

^{b)} Connectors with snap-in clips see chapter 00

Number of contacts

32

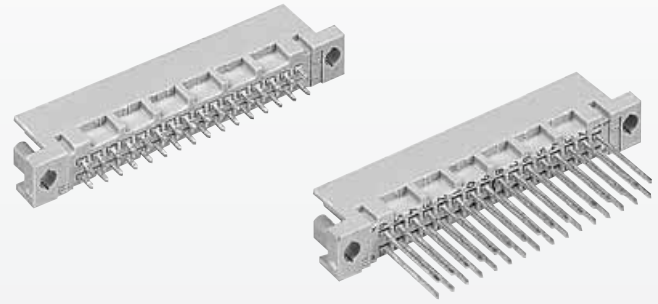

Male connectors

Identification	Number of contacts	Contact arrangement	Part No.			Performance levels according to IEC 60 603-2. Explanation chapter 00		
			3	2	1	3	2	1
Male connector with solder pins 2.5 mm	32		09 27 132 7902	09 27 132 6902	Performance level 1 on request			
Male connector with solder pins 4.0 mm	32		09 27 132 7903	09 27 132 6903				
Male connector with solder pins 13 mm	32			09 27 132 6577				
Male connector with wrap posts 13 mm	32		09 27 132 7907	09 27 132 6907				

Male connector with press-in pins

Part Nos. and variants see chapter 04

Dimensions

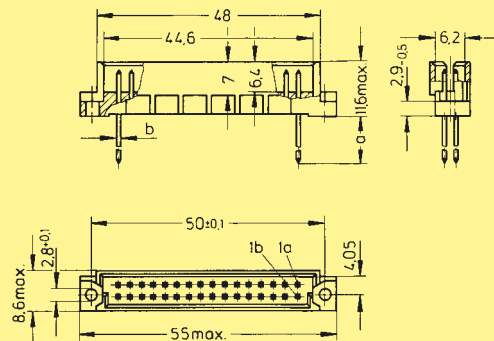

a	b
2.5	∅ 0.7
4	∅ 0.7
13	□ 0.6

Solder pins

a	b
13	□ 0.6

Wrap posts

Panel cut out

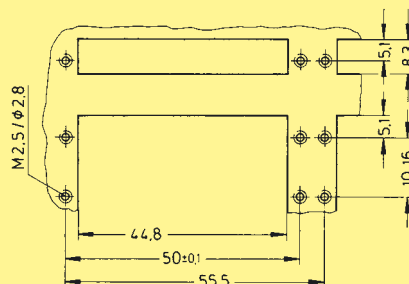

Board drillings

Mounting side

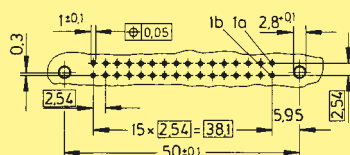

Dimensions in mm

Other contact arrangements as well with lagging/leading pins on request

DIN 41 612 · complementary type 2R



Number of contacts

48, 32

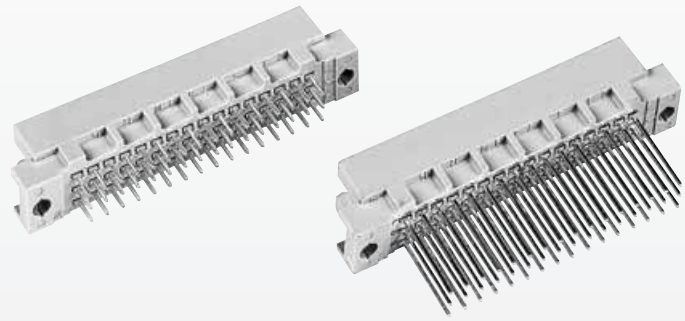

Male connectors

DIN Signal
to 2 A

Identification	Number of contacts	Contact arrangement	Part No.	Performance levels according to IEC 60 603-2. Explanation chapter 00		
				3	2	1
Male connector with solder pins 2.5 mm	48		09 28 148 7902 09 28 348 7902 ^{b)}	09 28 148 6902 09 28 348 6902 ^{b)}	09 28 148 2902	
	32		09 28 132 7902	09 28 132 6902	09 28 132 2902	
Male connector with solder pins 4.0 mm	48		09 28 148 7903	09 28 148 6903 09 28 348 6903 ^{b)}	09 28 148 2903	
	32		09 28 132 7903	09 28 132 6903	09 28 132 2903	
Male connector with solder pins 13 mm	48			09 28 148 6577		
Male connector with wrap posts 13 mm	48		09 28 148 7907	09 28 148 6907	09 28 148 2907	
	32		09 28 132 7907	09 28 132 6907	09 28 132 2907	

Male connector with press-in pins Part Nos. and variants see chapter 04

Dimensions

a	b	Solder pins
2.5	∅ 0.7	
4	∅ 0.6	

a	b	Wrap posts
13	∅ 0.6	

Panel cut out

Contact arrangement
View from termination side

Board drillings
Mounting side

Dimensions in mm

Other contact arrangements as well with lagging/leading pins on request
^{b)} Connectors with snap-in clips see chapter 00

DIN 41 612 · Type Q – complementary types 2Q, 2R



Number of contacts

64, 48, 32

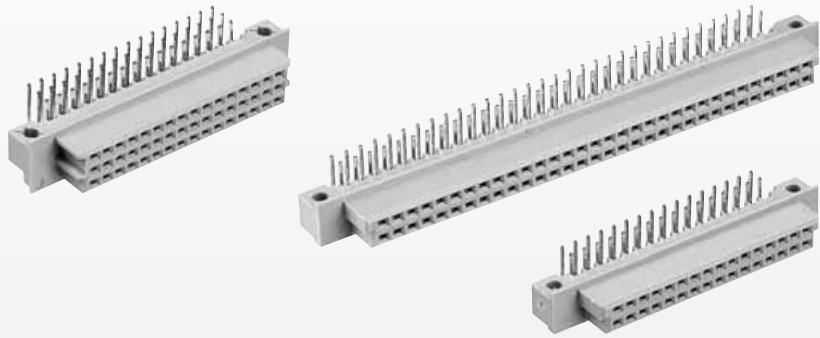

Female connectors

Identification Number of contacts Contact arrangement Performance level 2 according to IEC 60 603-2. Explanation chapter 00 Part No.

Female connector with angled solder pins

Type Q

64

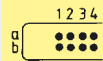

09 72 264 6801
 ◦09 72 464 6801^{c)}

Type 2Q

32

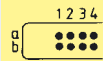

09 27 232 6801
 ◦09 27 432 6801^{c)}

Type 2R

48

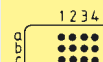

09 28 248 6801
 ◦09 28 448 6801^{c)}

Dimensions

Types Q / 2Q

Type 2R

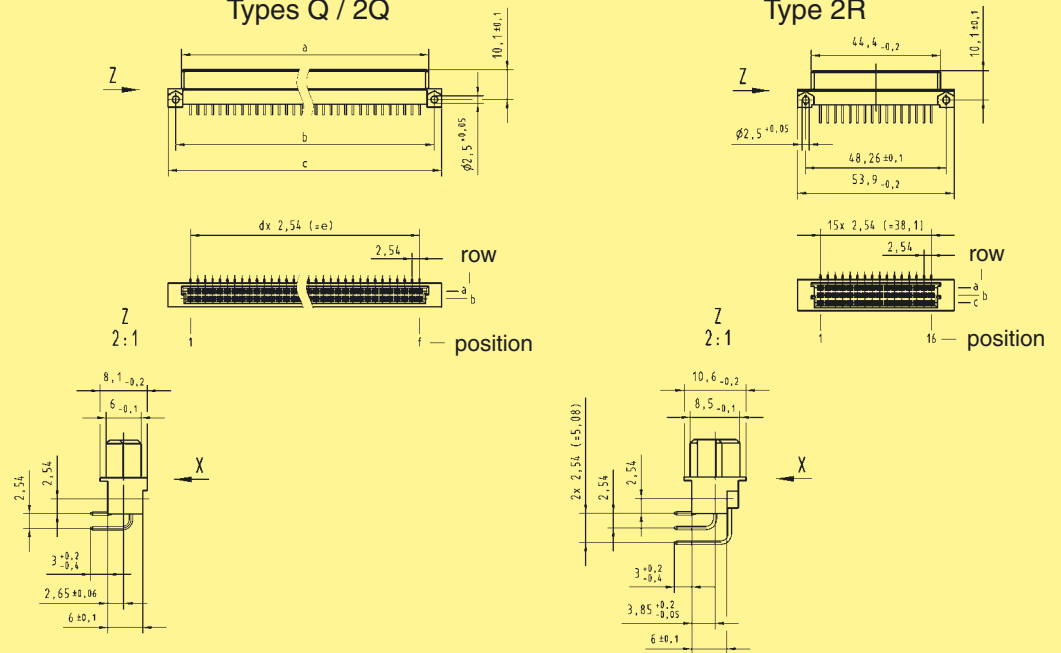

Type	a	b	c	d	e	f
Q	85.0 ^{-0.2}	88.90 ^{±0.1}	94.0 ^{-0.2}	31	78.74	32
2Q	44.4 ^{-0.2}	48.26 ^{±0.1}	53.9 ^{-0.2}	15	38.10	16

Board drillings

Mounting side

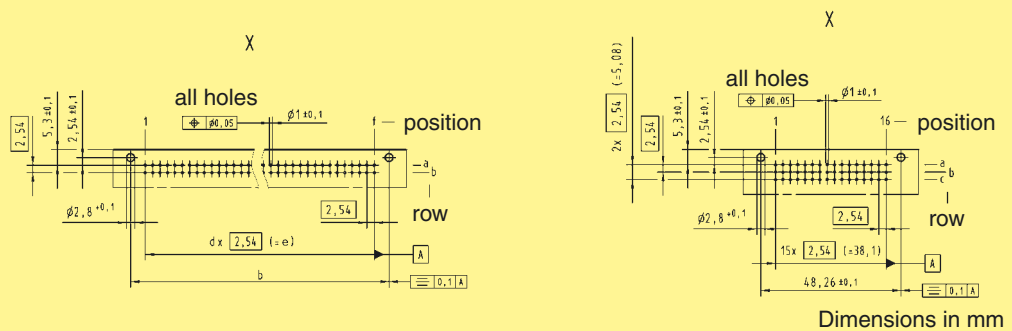

Dimensions in mm

Other contact arrangements on request
^{c)} Connectors with coding see page 01.44

DIN Signal to 2 A

Pin shroud



Number of contacts

96, 48

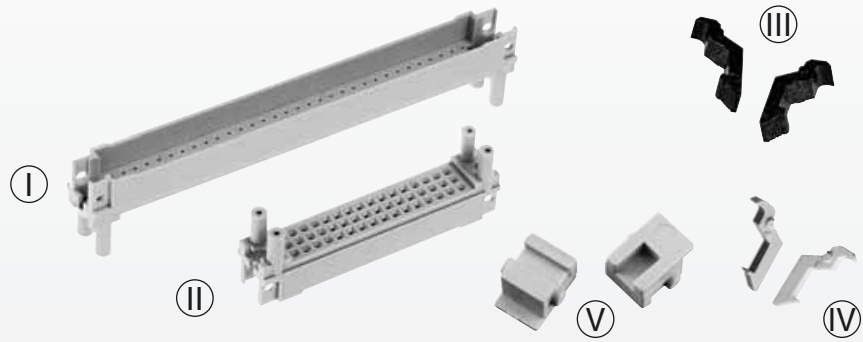

Pin shrouds for types C, 2C, R, 2R

DIN Signal to 2 A

Identification	Termination length ± 0.3	pcb-thickness ± 0.4	Dimension a ± 0.1	Part No. – Pin shrouds with	
				press-in fixing	screw fixing
Pin shrouds for female connectors type C, R I	13.0/ 13.2	1.6	6.7	09 03 000 9956	09 03 000 9966
		2.4	5.9	09 03 000 9957	09 03 000 9967
		3.2	5.1	09 03 000 9958	09 03 000 9968
		4.0	4.3	09 03 000 9959	09 03 000 9969
		17.0	1.6	9.9	09 03 000 9952
	17.0	2.4	9.1	09 03 000 9953	09 03 000 9963
		3.2	8.3	09 03 000 9954	09 03 000 9964
		4.0	7.5	09 03 000 9955	09 03 000 9965
		4.8	6.7	09 03 000 9956	09 03 000 9966
		5.6	5.9	09 03 000 9957	09 03 000 9967
		6.4	5.1	09 03 000 9958	09 03 000 9968
	20.0	3.2	11.5	09 03 000 9950	09 03 000 9960
		4.0	10.7	09 03 000 9951	09 03 000 9961
		4.8	9.9	09 03 000 9952	09 03 000 9962
		5.6	9.1	09 03 000 9953	09 03 000 9963
		6.4	8.3	09 03 000 9954	09 03 000 9964
		7.2	7.5	09 03 000 9955	09 03 000 9965
		Pin shrouds for female connectors type 2C, 2R II	13.0/ 13.2	1.6	6.7
2.4	5.9			09 23 000 9957	09 23 000 9967
3.2	5.1			09 23 000 9958	09 23 000 9968
4.0	4.3			09 23 000 9959	09 23 000 9969
17.0	1.6			9.9	09 23 000 9952
17.0	2.4		9.1	09 23 000 9953	09 23 000 9963
	3.2		8.3	09 23 000 9954	09 23 000 9964
	4.0		7.5	09 23 000 9955	09 23 000 9965
	4.8		6.7	09 23 000 9956	09 23 000 9966
	5.6		5.9	09 23 000 9957	09 23 000 9967
	6.4		5.1	09 23 000 9958	09 23 000 9968
20.0	3.2		11.5	09 23 000 9950	09 23 000 9960
	4.0		10.7	09 23 000 9951	09 23 000 9961
	4.8		9.9	09 23 000 9952	09 23 000 9962
	5.6		9.1	09 23 000 9953	09 23 000 9963
	6.4		8.3	09 23 000 9954	09 23 000 9964
	7.2		7.5	09 23 000 9955	09 23 000 9965

Identification	Part No.
Locking lever for female connectors type C, 2C* III	09 03 000 9914
Locking lever for female connectors type R, 2R* IV	09 03 000 9913
Fixing bracket for shell housing C* V	09 03 000 9921

01
40

* order 2 pieces per connector

Pin shroud



Number of contacts

96, 48

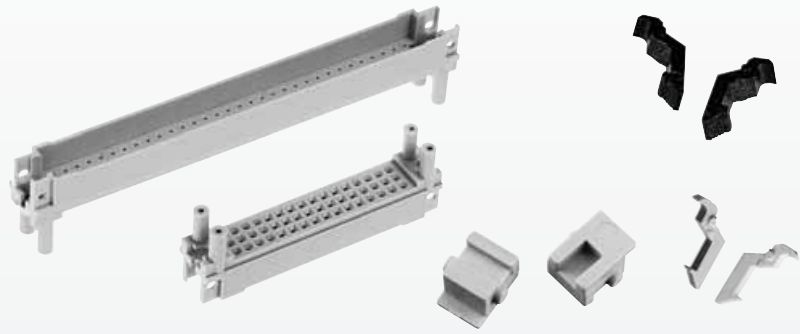

Pin shrouds
for types C, 2C, R, 2R

DIN Signal
to 2 A

Identification

Drawing

Dimensions in mm

Pin shrouds
for female connectors
type C, R

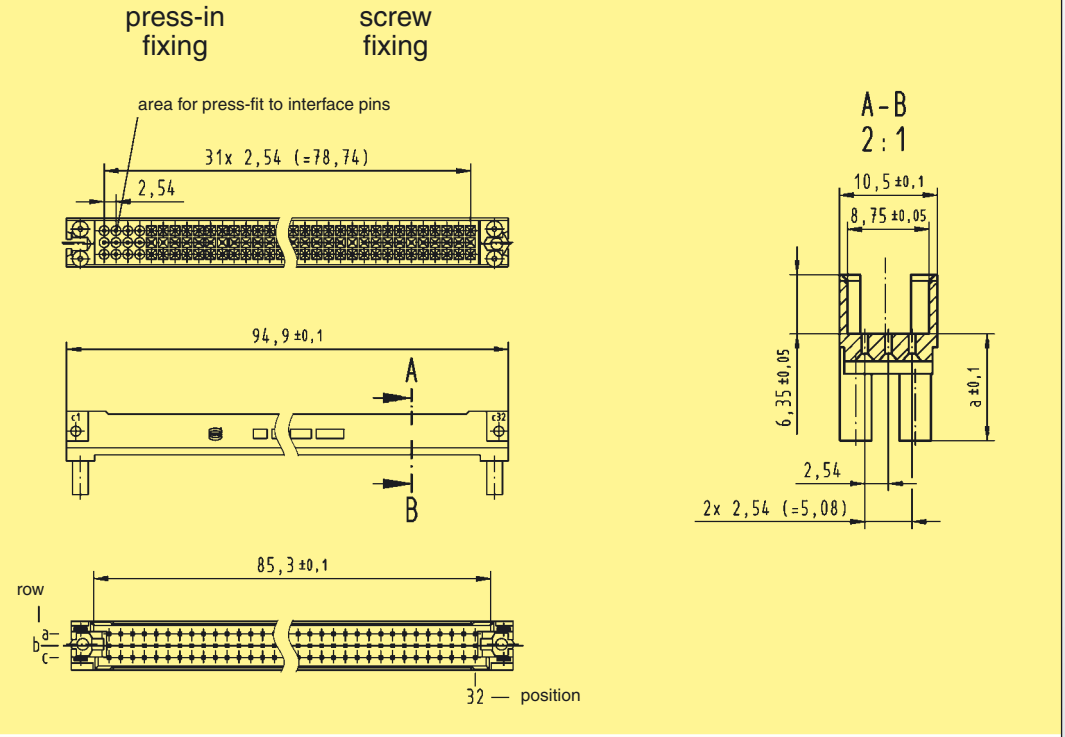

Pin shrouds
for female connectors
type 2C, 2R

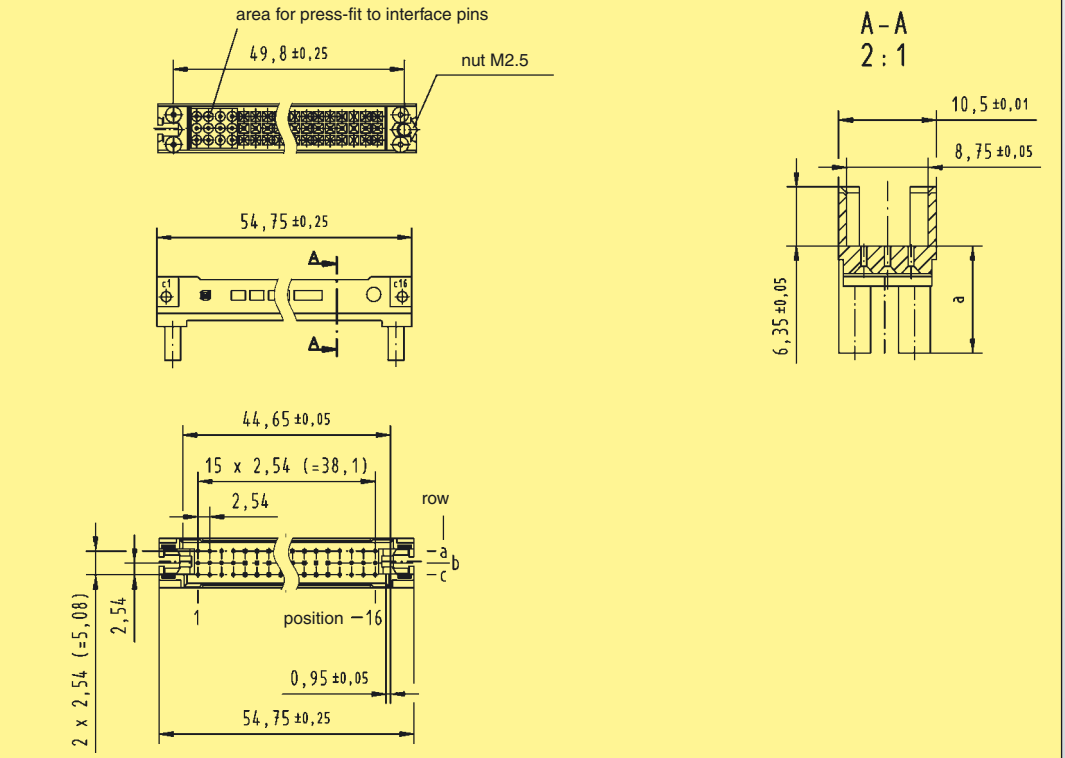

DIN Signal to 2 A

Application 1

Female connector
09 03 296 6861

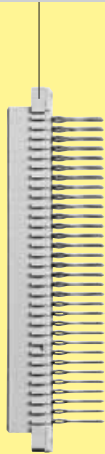

Backplane

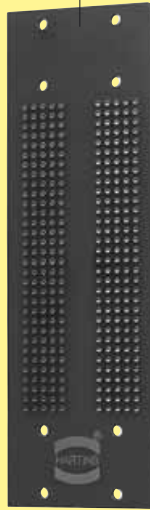

Pin shroud
09 03 000 9957



Locking lever
09 03 000 9914

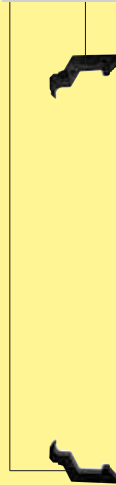

Female connector
09 03 264 6828



Female connector
09 03 096 3214

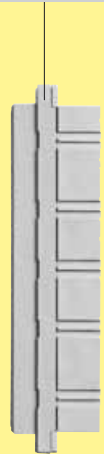

Application 2

Female connector
09 03 296 6862



Backplane

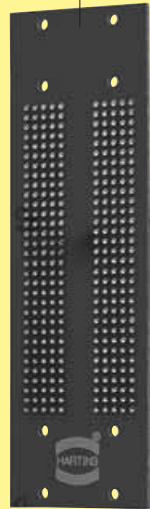

Pin shroud
09 03 000 9953



Locking lever
09 03 000 9913

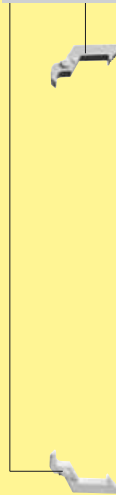

Female connector
09 73 296 6801



Daughtercard

Application 3

Female connector
09 03 296 6861

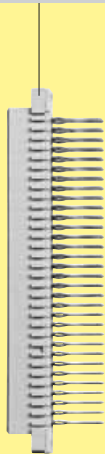

Backplane

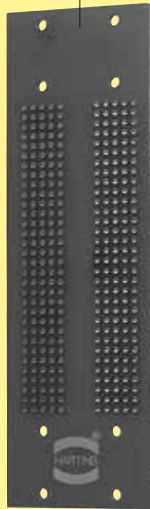

Pin shroud
09 03 000 9957



Fixing brackets
09 03 000 9921

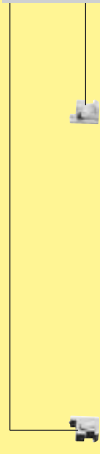

Female connector
09 03 096 3214



Locking levers
left 09 02 000 9902
right 09 02 000 9903

Shell housing C
09 03 096 0501

Application 4

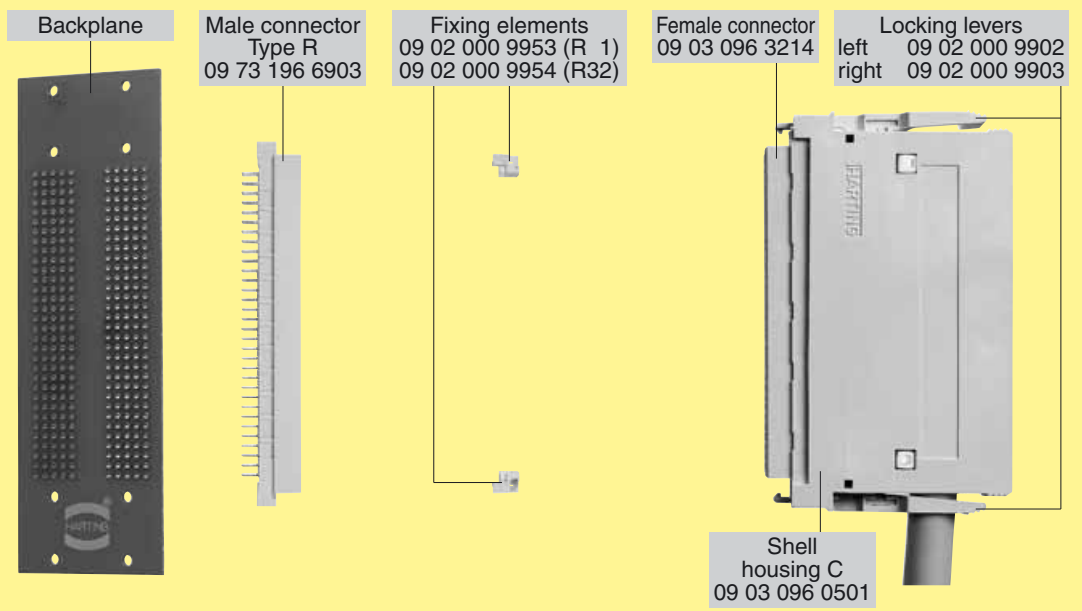

DIN Signal to 2 A

Application 5*

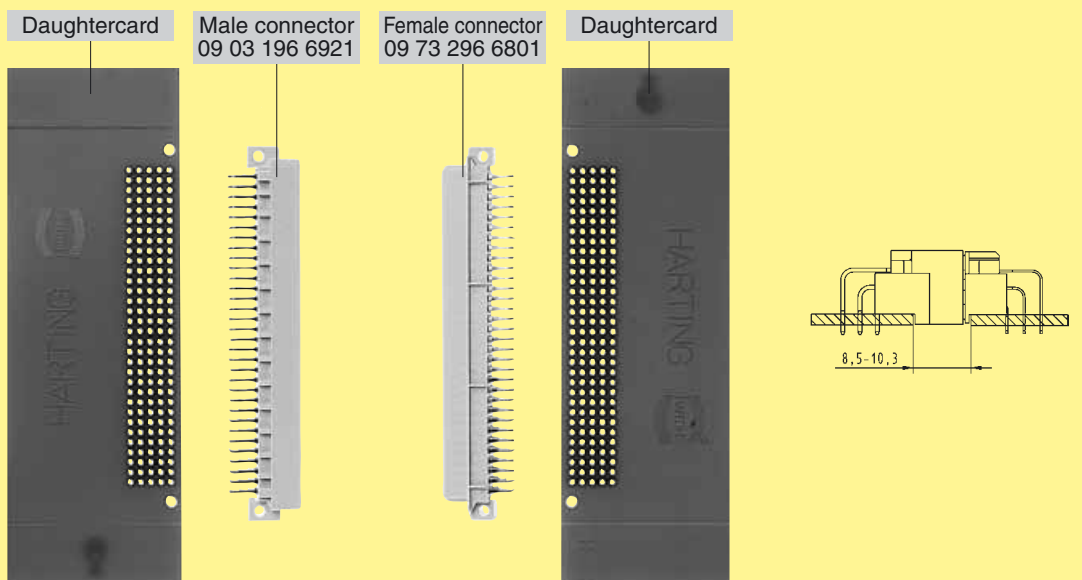

Application 6*

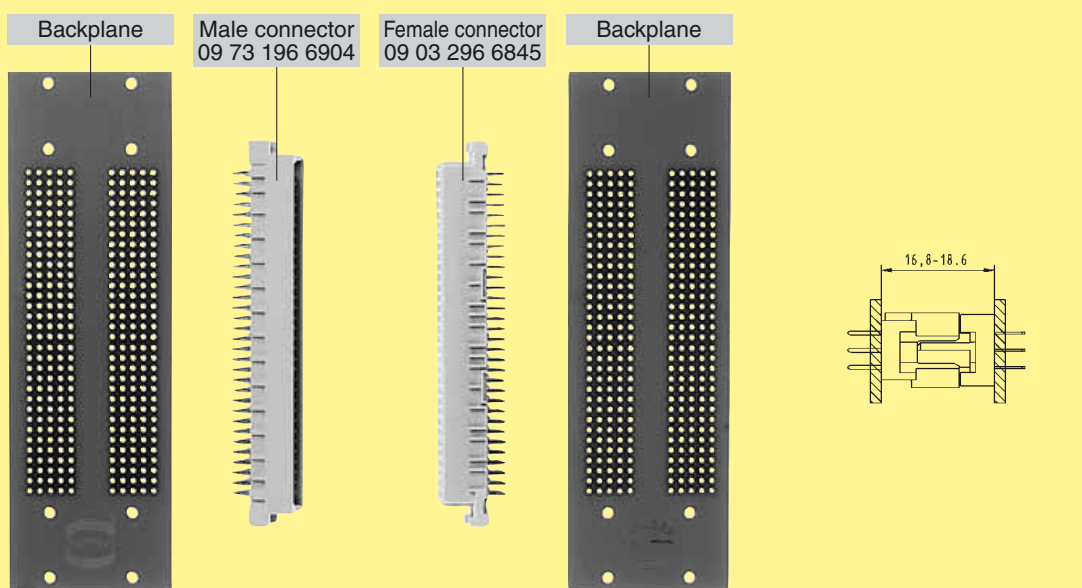

* Position marking turned: a1 <=> a32, a2 <=> a31, ...

DIN Signal to 2 A

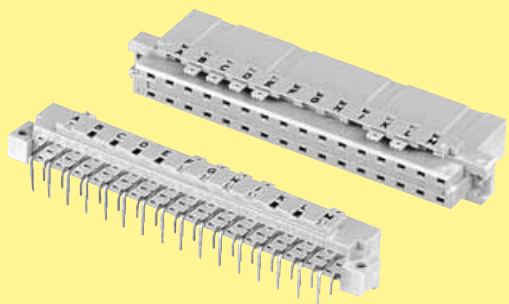
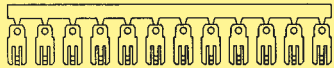
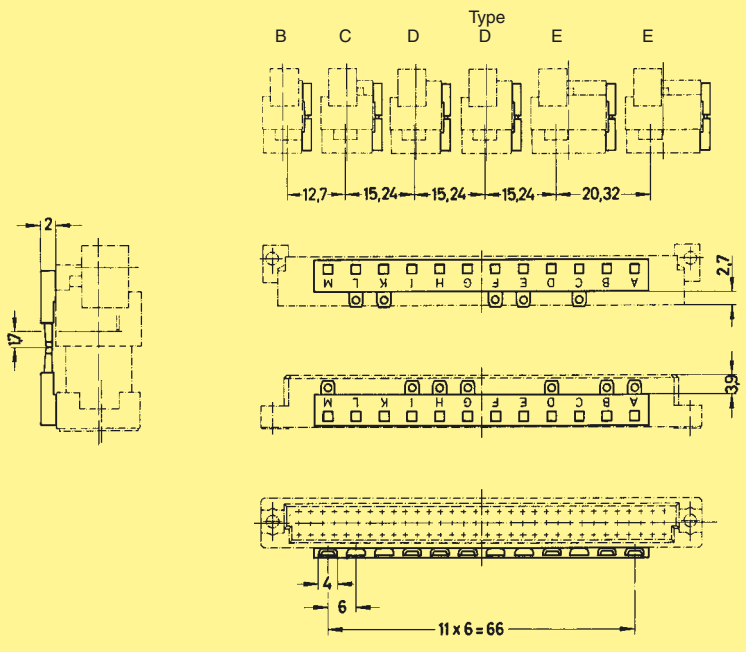
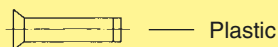
Identification	Part No.	Drawing	Dimensions in mm
<p>Coding system <u>without</u> contact loss</p>	<p>Male and female connectors</p> <p>Types B, C, D and E</p> <p>see product pages or on request</p>	<p>To avoid accidental and incorrect mating of adjacent connectors a coding system is required. This coding system is an integral part of both male and female connectors. A comb with 12 coding pins, which is supplied under a single part number, allows over 900 coding variations. The pins are to be locked into the male and female connectors.</p> <p>The connectors with the integrated coding facility are supplied for types B, C, D and E and are available for all variants.</p> <p>Please contact us.</p> 	
<p>Coding pins</p> <p>Mounting example</p>	<p>12 pins on a comb</p> <p>09 02 000 9928</p>	 	
<p>Coding system <u>with</u> contact loss</p>	<p>Code pin for types B, 2B, C, 2C, 3C, M, M-flat, Q, 2Q, R, R (HE 11), 2R, har-bus 64</p> <p>09 02 000 9901</p> <p>Removal tool for male contacts</p> <p>09 99 000 0133</p>	<p>To avoid accidental and incorrect mating of adjacent connectors a coding system is required. The coding is achieved by means of a code pin which is inserted into the selected chamber of the female connector (the contact cavity must be filled with a female contact!). The opposite male contact must be removed with the help of the specially designed tool.</p>  <p>Plastic</p> 