

| REVISION RECORD |     |             |      |      |
|-----------------|-----|-------------|------|------|
| REV             | ECN | DESCRIPTION | DRFT | DATE |

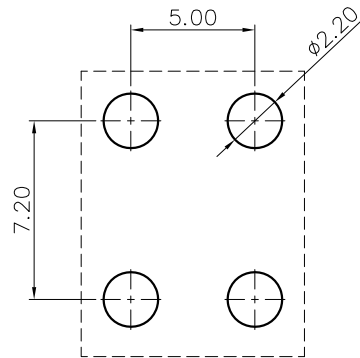

PCB LAYOUT

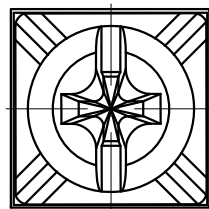
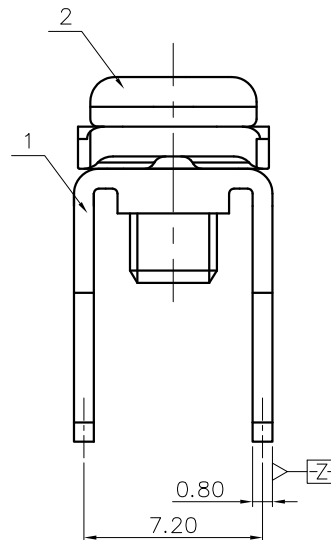
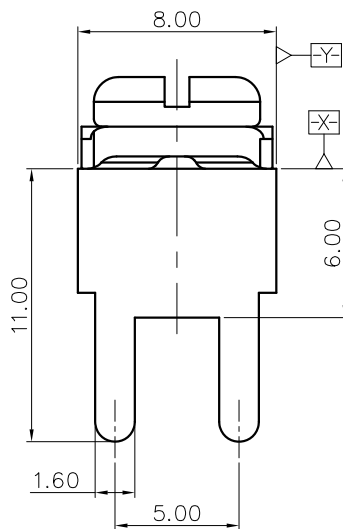

NOTES:

1. Rated current : 15A
2. Torque value : M3.5 , 7.02Lb.in
3. Dimension shall be interpreted per ASME Y14.5-2009
4. Undimensioned tolerances:

| Pitch range in mm |       | Nominal dimension range in mm |       |       |       |       |       | 0.1/10 |     |     |
|-------------------|-------|-------------------------------|-------|-------|-------|-------|-------|--------|-----|-----|
| To                | Over  | To                            | Over  | To    | Over  | To    | Over  |        |     |     |
| 6                 | 10    | 6                             | 10    | 10    | 30    | 30    | 60    | 100    | 150 | ±2' |
| ±0.15             | ±0.20 | ±0.30                         | ±0.30 | ±0.50 | ±0.70 | ±1.00 | ±1.30 |        |     |     |

5. RoHS Compliance

| ITEM | NAME OF PART | MATERIAL     | NOTES     |
|------|--------------|--------------|-----------|
| 2    | Screw        | Steel        | Ni Plated |
| 1    | Pin header   | Copper alloy | Sn Plated |

|                        |                      |                                   |                      |            |
|------------------------|----------------------|-----------------------------------|----------------------|------------|
| DETACHED LISTS         | PART NO.:            | /                                 |                      |            |
|                        | APPD:                | NAME:                             |                      |            |
|                        | CHKD:                | NINGBO DEGSON ELECTRICAL CO., LTD |                      |            |
|                        | DRFT: Yz 01/19/16"   | TITLE: CUSTOMER DRAWING           |                      | REV: T0-1  |
|                        | DRAWING NO.: K14-C02 |                                   | SHEET: 1/1           | SCALE: 1:1 |
| THIRD ANGLE PROJECTION |                      | MM (INCH)                         | DO NOT SCALE DRAWING | SCALE: 1:1 |

H | G | F | E | D | C | B | A