

REV.	DESCRIPTION	DRAWN	DATE
1	INITIAL RELEASE	FROS	2024/01/03

SPECIFICATION:

- ELECTRICAL**
 - Current Rating: 0.5A per pin
 - Voltage Rating: 10V DC
 - Contact Resistance: 100mΩ Max.
 - Insulation Resistance: 1000MΩ
 - Dielectric Withstanding Voltage: 500VAC
- MECHANICAL**
 - Durability: 5,000 cycles
 - Contact Normal Force: 0.5N Max. per pin
 - Tray Lock Force: 3N Min.
- ENVIRONMENTAL**
 - Operating temperature range: -40°C~+105°C
 - Storage temperature range: -40°C~+85°C
- SOLDER ABILITY**
 - Recommended IR-Reflow Temperature: 260°C

This part (115U-B200) is a connector only, it should be used together with Card-Tray (see page 3, tray spec. table)

6	CRANK	Stainless Steel
5	SPRING	SWP-B, Nickel plating
4	SLIDER	LCP, UL94V-0, Black
3	SHELL	Stainless Steel, Nickel plating
	LOWER LAYER	Contact: Copper alloy, Gold plating over Nickel
2	MOLDING	Insulator: LCP, UL94V-0, Black
	UPPER LAYER	Contact: Copper alloy, Gold plating over Nickel
1	MOLDING	Insulator: LCP, UL94V-0, Black

NO.	PART NAME	DESCRIPTION
UNLESS OTHERWISE SPECIFIED TOLERANCE		
UNIT:	DECIMAL	LINEAR ANGLES
mm	X.	±0.50 ±5°
	X.X	±0.25 ±3°
	X.XX	±0.12 ±1°
		www.attend.com.tw
DRAWN	Fros	2024/01/03
CHECKED	Tim	2024/01/03
APPROVED	Ken	2024/01/03
SCALE	2/1	SHEET 1/4
SIZE	A4	
DRAWN NAME:	Micro SD and Micro/Nano SIM Socket, Stack Type	
PRODUCT NO.	115U-B200	
FILE NAME	115U-B200_B_1	

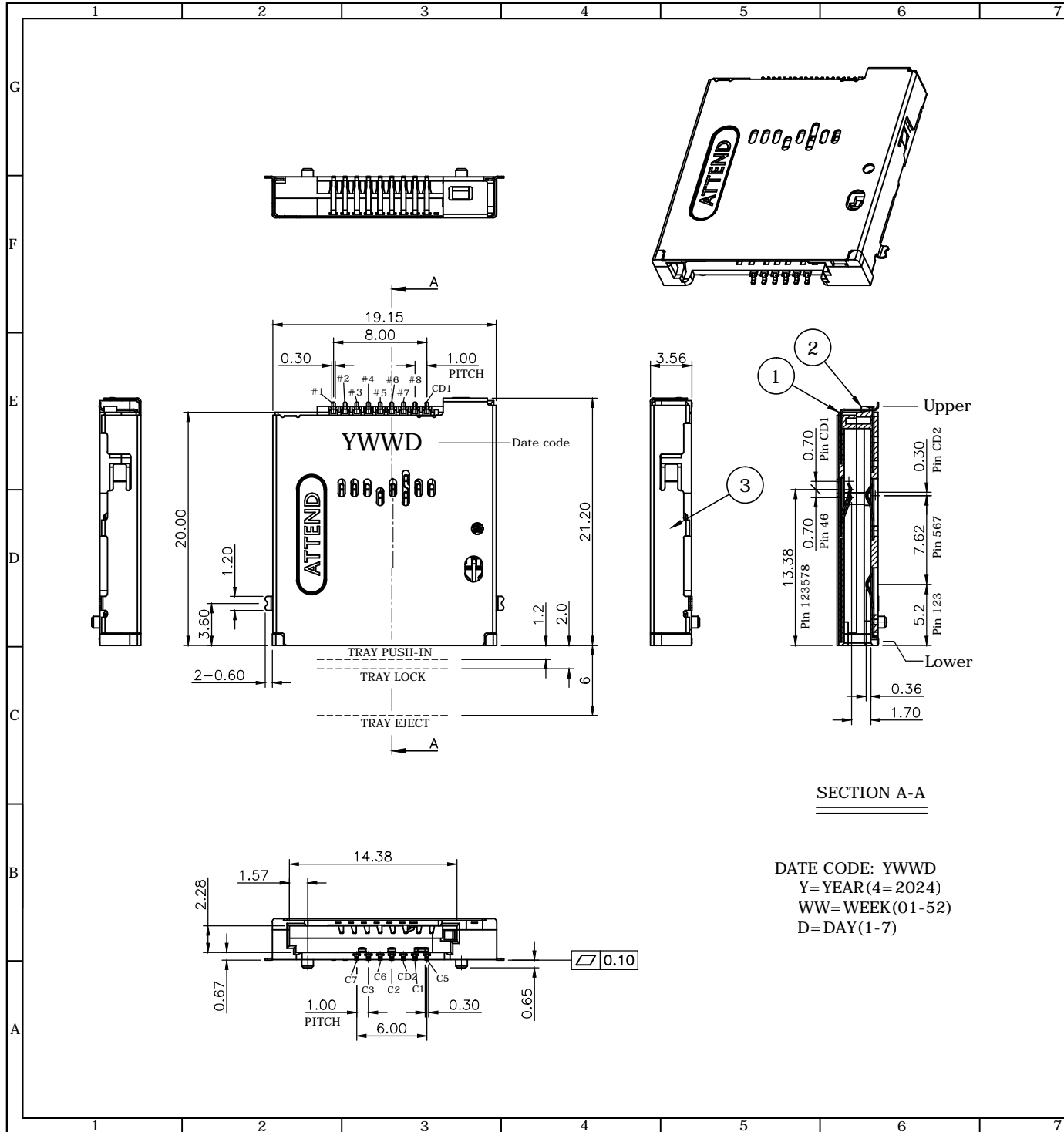

SECTION A-A

DATE CODE: YWWD
 Y= YEAR(4=2024)
 WW= WEEK(01-52)
 D= DAY(1-7)

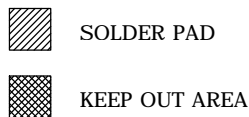
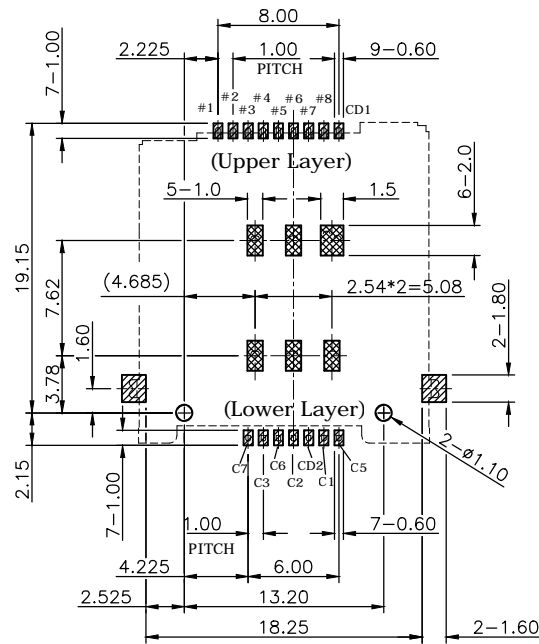
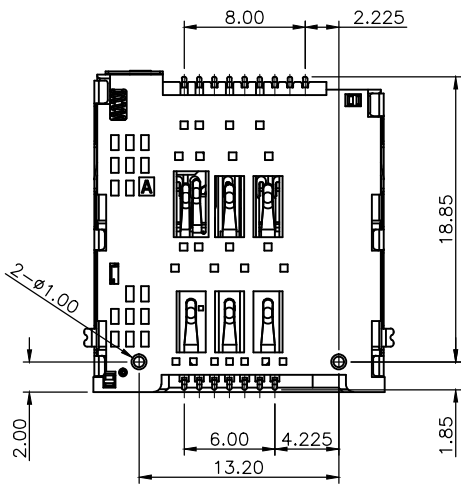

RECOMMENDED LAYOUT (TOP VIEW)
GENERAL TOLERANCE: $\pm 0.05\text{mm}$

REV.	DESCRIPTION	DRAWN	DATE

Card Detect Circuit: (Normal OPEN)

1. Tray with card

	Tray inserted	Tray Ejected
Upper Layer	#6 CD1	#6 CD1
Lower Layer	C5 CD2	C5 CD2

2. Tray without card

	Tray inserted	Tray Ejected
Upper Layer	#6 CD1	#6 CD1
Lower Layer	C5 CD2	C5 CD2

Pin Assignment:

Upper Layer (Micro SD)		Lower Layer (Micro/Nano SIM)	
Pin NO.	Pin Name	Pin NO.	Pin Name
#1	DAT2	C 1	VCC
#2	CD/DAT3	C 2	RST
#3	CMD	C 3	CLK
#4	VDD	C 5	GND
#5	CLK	C 6	VPP
#6	VSS	C 7	I/O
#7	DAT0	CD2	Card Detect 2
#8	DAT1		
CD1	Card Detect 1		

UNLESS OTHERWISE SPECIFIED TOLERANCE			
UNIT:	DECIMAL	LINEAR	ANGLES
mm	X.	± 0.50	$\pm 5^\circ$
	X.X	± 0.25	$\pm 3^\circ$
	X.XX	± 0.12	$\pm 1^\circ$



www.attend.com.tw

DRAWN	Fros	2024/01/03	DRAWN NAME:	Micro SD and Micro/Nano SIM Socket, Stack Type
CHECKED	Tim	2024/01/03		Tray Push-Push, w/Lock and Switch, 10u"
APPROVED	Ken	2024/01/03	PRODUCT NO.	115U-B200
	SCALE 2/1	SHEET 2/4	SIZE A4	FILE NAME 115U-B200_B_1

REV.	DESCRIPTION	DRAWN	DATE

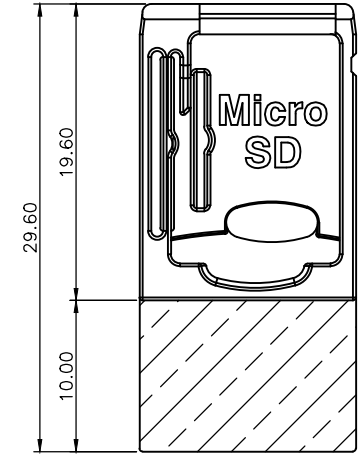
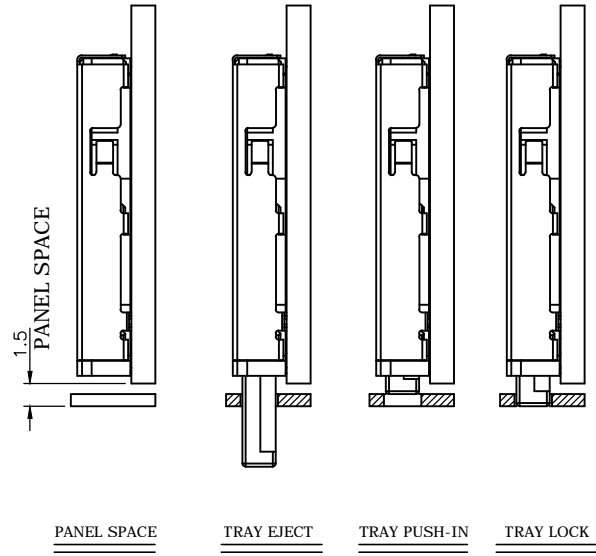
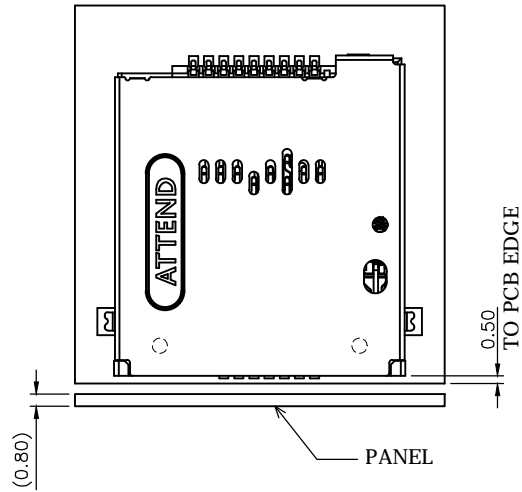

Length and form can be customized within 10mm.

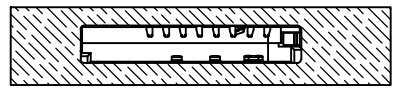
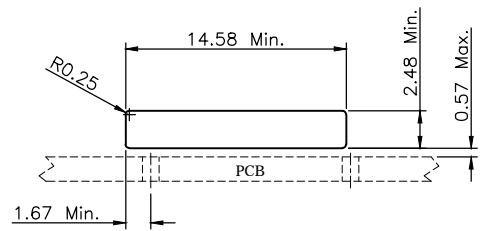

RECOMMENDED PANEL CUT

UNLESS OTHERWISE SPECIFIED TOLERANCE						 www.attend.com.tw
UNIT:	DECIMAL	LINEAR	ANGLES			
mm	X.	±0.50	±5°			
	X.X	±0.25	±3°			
	X.XX	±0.12	±1°			
DRAWN	Fros	2024/01/03	DRAWN NAME:			
CHECKED	Tim	2024/01/03	Micro SD and Micro/Nano SIM Socket, Stack Type			
APPROVED	Ken	2024/01/03	Tray Push-Push, w/Lock and Switch, 10u"			
	SCALE	SHEET	SIZE	PRODUCT NO.	115U-B200	
	2/1	3/4	A4	FILE NAME	115U-B200_B_1	

REV.	DESCRIPTION	DRAWN	DATE

Nano SIM card assembly and disassembly:

ASSEMBLY

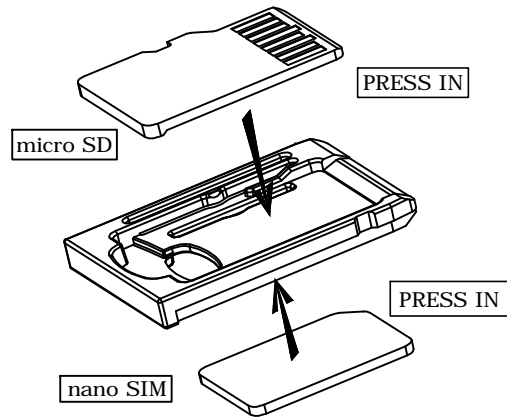

DISASSEMBLY

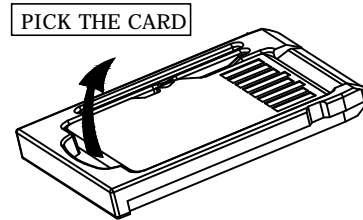

Card Clip hold Nano SIM card make it won't fall.

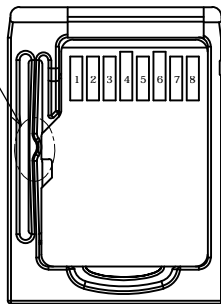

micro SD

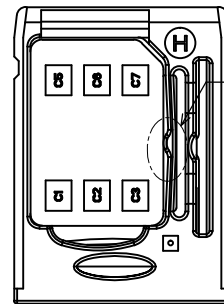
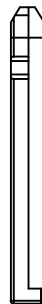

Nano SIM

Card Clip hold Nano SIM card make it won't fall.

UNLESS OTHERWISE SPECIFIED TOLERANCE							
UNIT:	DECIMAL	LINEAR	ANGLES				
mm	X.	±0.50	±5°				
	X.X	±0.25	±3°				
	X.XX	±0.12	±1°				
DRAWN	Fros	2024/01/03	DRAWN NAME: Micro SD and Micro/Nano SIM Socket, Stack Type Tray Push-Push, w/Lock and Switch, 10u"				
CHECKED	Tim	2024/01/03					
APPROVED	Ken	2024/01/03					
SCALE	2/1	SHEET	4/4	SIZE	A4	PRODUCT NO.	115U-B200
FILE NAME		115U-B200_B_1					



www.attend.com.tw

G
F
E
D
C
B
A

G
F
E
D
C
B
A

1 2 3 4 5 6 7 8 9 10

1 2 3 4 5 6 7 8 9 10

REV.	DESCRIPTION	DRAWN	DATE
1	INITIAL RELEASE	FROS	2024/01/03

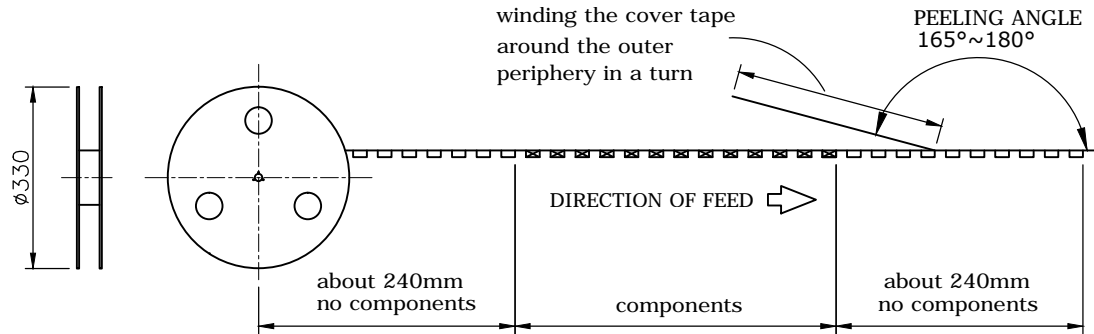

PACKAGING SPECIFICATION:

1. MATERIAL

- 1.1 Embossed Carrier Tape: PS Black
- 1.2 Top Cover Tape: PET
20-80g (Peel Speed 300mm/Minute)
- 1.3 Taping Reel: Paper

2. PACKING

- 2.1 Quantity:
450 Piece/Reel
2700 Piece/Outer Carton

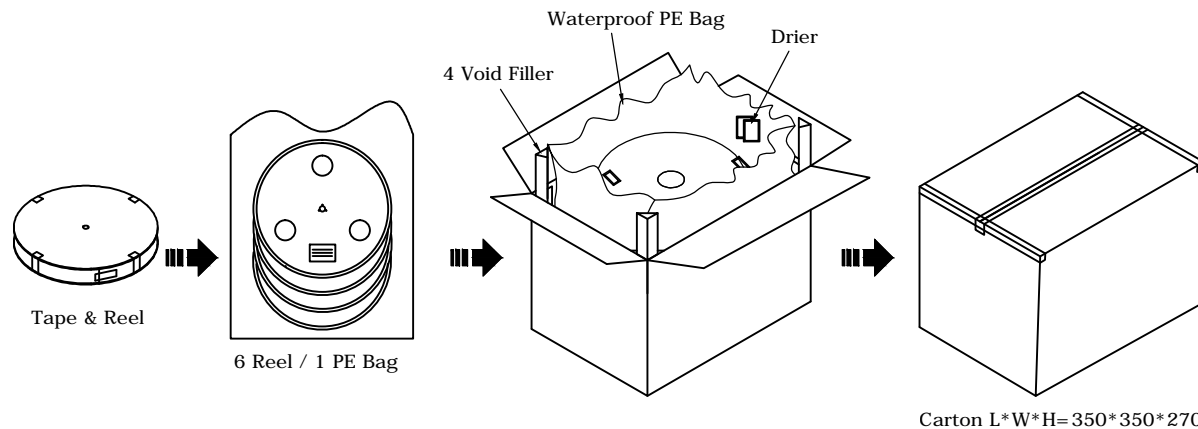
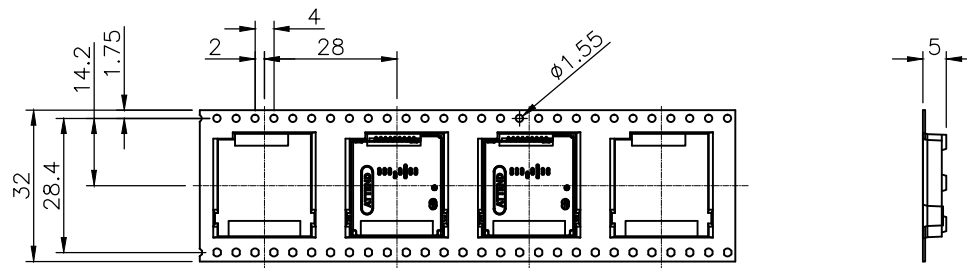

UNLESS OTHERWISE SPECIFIED TOLERANCE			
UNIT:	DECIMAL	LINEAR	ANGLES
mm	X.	±0.50	±5°
	X.X	±0.25	±3°
	X.XX	±0.12	±1°



www.attend.com.tw

DRAWN	Fros	2024/01/03	DRAWN NAME:	Micro SD and Micro/Nano SIM Socket, Stack Type	
CHECKED	Tim	2024/01/03	Tray Push-Push, w/Lock and Switch, 10u"		
APPROVED	Ken	2024/01/03	PRODUCT NO.	115U-B200	
SCALE	N/A	SHEET	1/1	SIZE	A4
FILE NAME			115U-B200_D_1		