

Datasheet

APM32F405xG

APM32F407xExG

Arm[®] Cortex[®] -M4F -based 32-bit MCU

Chip version: Version A

Manual version: V1.7

1 Product Characteristics

■ Core

- 32-bit Arm® Cortex®-M4F core with FPU
- Up to 168MHz working frequency

■ Memory and interface

- Flash: The capacity is up to 1MB
- SRAM: System (192KB) + backup (4KB)
- EMMC: Support CF card, SRAM, PSRAM, SDRAM, NOR and NAND memories

■ Clock

- HSECLK: 4~26MHz external crystal/ceramic oscillator supported
- LSECLK: 32.768KHz crystal/ceramic oscillator supported
- HSICLK: 16MHz RC oscillator calibrated by factory
- LSICLK: 28KHz RC oscillator supported
- PLL1: Phase locked loop; output frequency is configured by four parameters
- PLL2: Phase locked loop specially used to provide clock signals to I2S; output frequency is configured by three parameters

■ Reset and power management

- V_{DD} range: 1.8~3.6V
- V_{DDA} range: 1.8~3.6V
- V_{BAT} range of backup domain power supply: 1.65V~3.6V
- Power-on/power-down/brown-out reset (POR/PDR/BOR) supported
- Programmable power supply voltage detector (PVD) supported

■ Low-power mode

- Sleep, stop and standby modes supported

■ DMA

- Two DMA; each DMA has 8 data streams, 16 in total

■ Debugging interface

- JTAG
- SWD

■ I/O

- Up to 140 I/O
- All I/O can be mapped to external interrupt vector
- Up to 139 FT input I/O

■ Communication peripherals

- 4 USART, 2 UART, supporting ISO7816, LIN and IrDA functions
- 3 I2C, supporting SMBus/PMBus
- 3 SPI (2 reusable I2S)
- 2 CAN
- 3 USB_OTG controllers
- 1 SDIO interface
- 1 Ethernet

■ Analog peripherals

- 3 12-bit ADCs
- 2 12-bit DACs

■ Timer

- 2 16-bit advanced timers TMR1/8 that can provide 7-channel PWM output, support dead zone generation and braking input functions
- 2 32-bit general-purpose timers TMR2/5, each with up to 4 independent channels to support input capture, output comparison, PWM, pulse count and other functions
- 8 16-bit general-purpose timers TMR3/4/9/10/11/12/13/14, each with up to 2 independent channels to support input capture, output comparison, PWM, pulse count and other functions
- 2 16-bit basic timers TMR6/7
- 2 watchdog timers: one independent watchdog IWDT and one window watchdog WWDT
- 1 24-bit autodecrement SysTick Timer

■ RTC

- Support calendar function
- Alarm and regular wake-up from stop/standby mode

■ CRC computing unit

■ 96-bit unique device ID

Contents

1	Product Characteristics	1
2	Product Information	6
3	Pin Information	7
3.1	Pin distribution	7
3.2	Pin function description	10
3.3	GPIO Multiplexing Function Configuration	28
4	Function Description	46
4.1	System architecture.....	47
4.1.1	System block diagram	47
4.1.2	Address mapping	48
4.1.3	Startup configuration	50
4.2	Core	50
4.3	Interrupt controller	50
4.3.1	Nested Vector Interrupt Controller (NVIC)	50
4.3.2	External Interrupt/Event Controller (EINT).....	51
4.4	On-chip memory.....	51
4.4.1	Configurable external memory controller (EMMC)	51
4.4.2	LCD parallel interface (LCD)	51
4.5	Clock.....	52
4.5.1	Clock tree	52
4.5.2	Clock source.....	54
4.5.3	System clock	54
4.5.4	Bus clock	54
4.5.5	Phase locked loop	54
4.6	Power and power management	54
4.6.1	Power supply scheme	54
4.6.2	Voltage regulator	55
4.6.3	Power supply voltage monitor	55

4.7	Low-power mode.....	55
4.8	DMA.....	56
4.9	GPIO.....	56
4.10	Communication peripherals	56
4.10.1	USART/UART.....	56
4.10.2	I2C	57
4.10.3	SPI/I2S	57
4.10.4	CAN	57
4.10.5	USB_OTG	57
4.10.6	Ethernet.....	57
4.10.7	SDIO.....	58
4.11	Analog peripherals	58
4.11.1	ADC.....	58
4.11.2	DAC.....	58
4.12	Timer.....	59
4.13	RTC	61
4.13.1	Backup domain.....	61
4.14	RNG.....	61
4.15	DCI.....	61
4.16	CRC.....	61
5	Electrical Characteristics	61
5.1	Test conditions of electrical characteristics.....	61
5.1.1	Maximum and minimum values.....	61
5.1.2	Typical value.....	62
5.1.3	Typical curve.....	62
5.1.4	Power supply scheme	63
5.1.5	Load capacitance	64
5.2	Test under general operating conditions.....	64
5.3	Absolute maximum ratings.....	65
5.3.1	Maximum temperature characteristics.....	65

5.3.2	Maximum rated voltage characteristics.....	65
5.3.3	Maximum rated current characteristics	65
5.3.4	Electro-static discharge (ESD).....	66
5.3.5	Static latch-up (LU).....	66
5.4	On-chip memory.....	66
5.4.1	Flash characteristics.....	66
5.5	Clock.....	67
5.5.1	Characteristics of external clock source	67
5.5.2	Characteristics of internal clock source	68
5.5.3	PLL Characteristics	69
5.6	Reset and power management.....	69
5.6.1	Test of Embedded Reset and Power Control Module Characteristics.....	69
5.7	Power consumption.....	71
5.7.1	Power consumption test environment.....	71
5.7.2	Power consumption in run mode.....	72
5.7.3	Power consumption in sleep mode	75
5.7.4	Power consumption in stop mode.....	76
5.7.5	Power consumption in standby mode	76
5.7.6	Peripheral power consumption.....	77
5.7.7	Backup Domain Power Consumption	79
5.8	Wake-up time in low-power mode.....	79
5.9	I/O port characteristics	80
5.10	NRST pin characteristics.....	82
5.11	Communication peripherals	83
5.11.1	I2C peripheral characteristics.....	83
5.11.2	SPI peripheral characteristics	84
5.12	Analog peripherals	86
5.12.1	ADC	86
5.12.2	DAC	88
6	Package Information	90

6.1	LQFP176 package information	90
6.2	LQFP144 package information	92
6.3	LQFP100 package information	95
6.4	LQFP64 package information	98
7	Packaging Information.....	101
7.1	Reel packaging.....	101
7.2	Tray packaging.....	102
8	Ordering Information	104
9	Commonly Used Function Module Denomination.....	106
10	Version History	107

2 Product Information

See the following table for APM32F405xG 407xExG product functions and peripheral configuration.

Table 1 Functions and Peripherals of APM32F405xG 407xExG Series Chips

Product		APM32F407								APM32F405		
Model		RET6	RGTx	VET6	VGTx	ZET6	ZGT6	IET6	IGT6	RGT6	VGT6	ZGT6
Package		LQFP64		LQFP100		LQFP144		LQFP176		LQFP64	LQFP100	LQFP144
Core and maximum working frequency		Arm® 32-bit Cortex®-M4F@168MHz										
Working voltage		1.8~3.6V										
Flash(KB)		512	1024	512	1024	512	1024	512	1024	1024		
System + backup SRAM(KB)		192+4										
SMC		0		1						0		1
DMC		0						1		0		
GPIOs		51		82		114		140		51	82	114
Communication interface	USART/UART	4/2										
	SPI/I2S	3/2										
	I2C	3										
	OTG_FS	1										
	OTG_HS	2										
	CAN	2										
	Ethernet	0		1						0		
	SDIO	1										
Timer	16-bit advanced	2										
	32-bit general	2										
	16-bit general	8										
	16-bit basic	2										
	System tick timer	1										
	Watchdog	2										
Real-time clock		1										
DCI		0		1						0		
RNG		1										
12-bit ADC	Unit	3										
	Channel	16				24				16		24
12 位 DAC	Unit	2										
	Channel	2										
Operating temperature		Ambient temperature: -40°C to 85°C/-40°C to 105°C Junction temperature: -40°C to 105°C/-40°C to 125°C										

Note: When x=6, the ambient temperature: -40°C to 85°C, the junction temperature: -40°C to 105°C;
When x=7, the ambient temperature: -40°C to 105°C, the junction temperature: -40°C to 125°C;

3 Pin Information

3.1 Pin distribution

Figure 1 Distribution Diagram of APM32F407xExG Series LQFP176 Pins

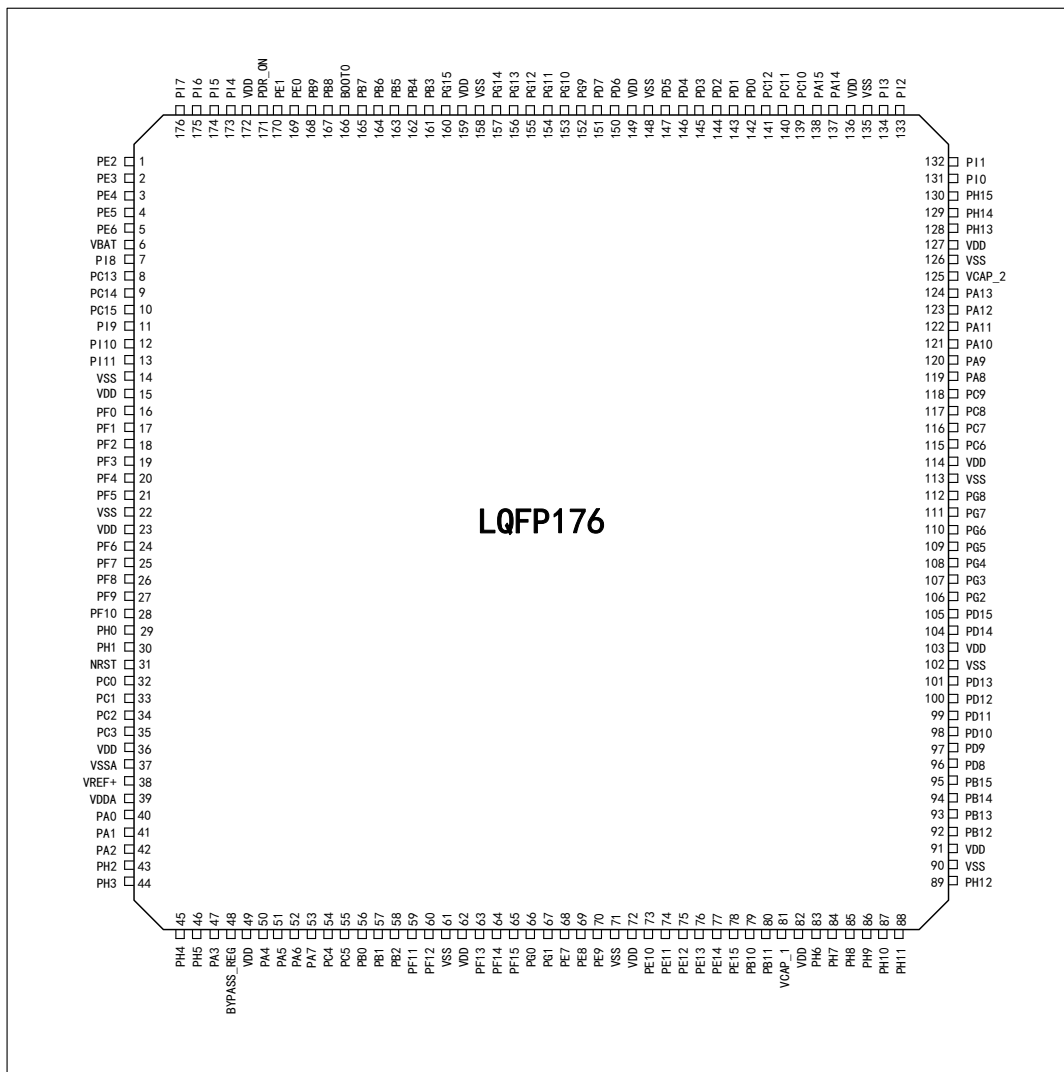

Figure 2 Distribution Diagram of APM32F405xG 407xExG Series LQFP144 Pins

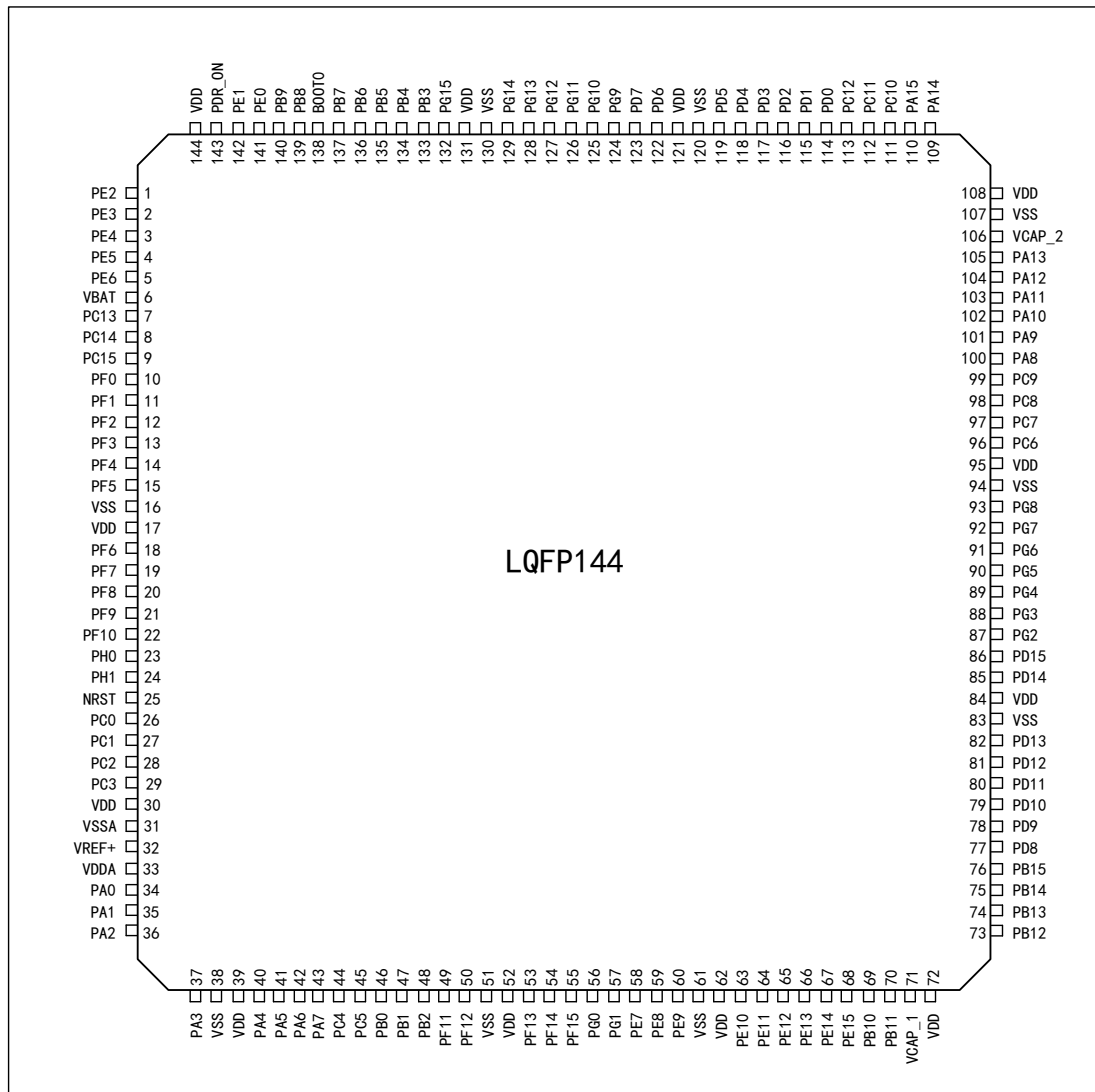

Figure 3 Distribution Diagram of APM32F405xG 407xExG Series LQFP100 Pins

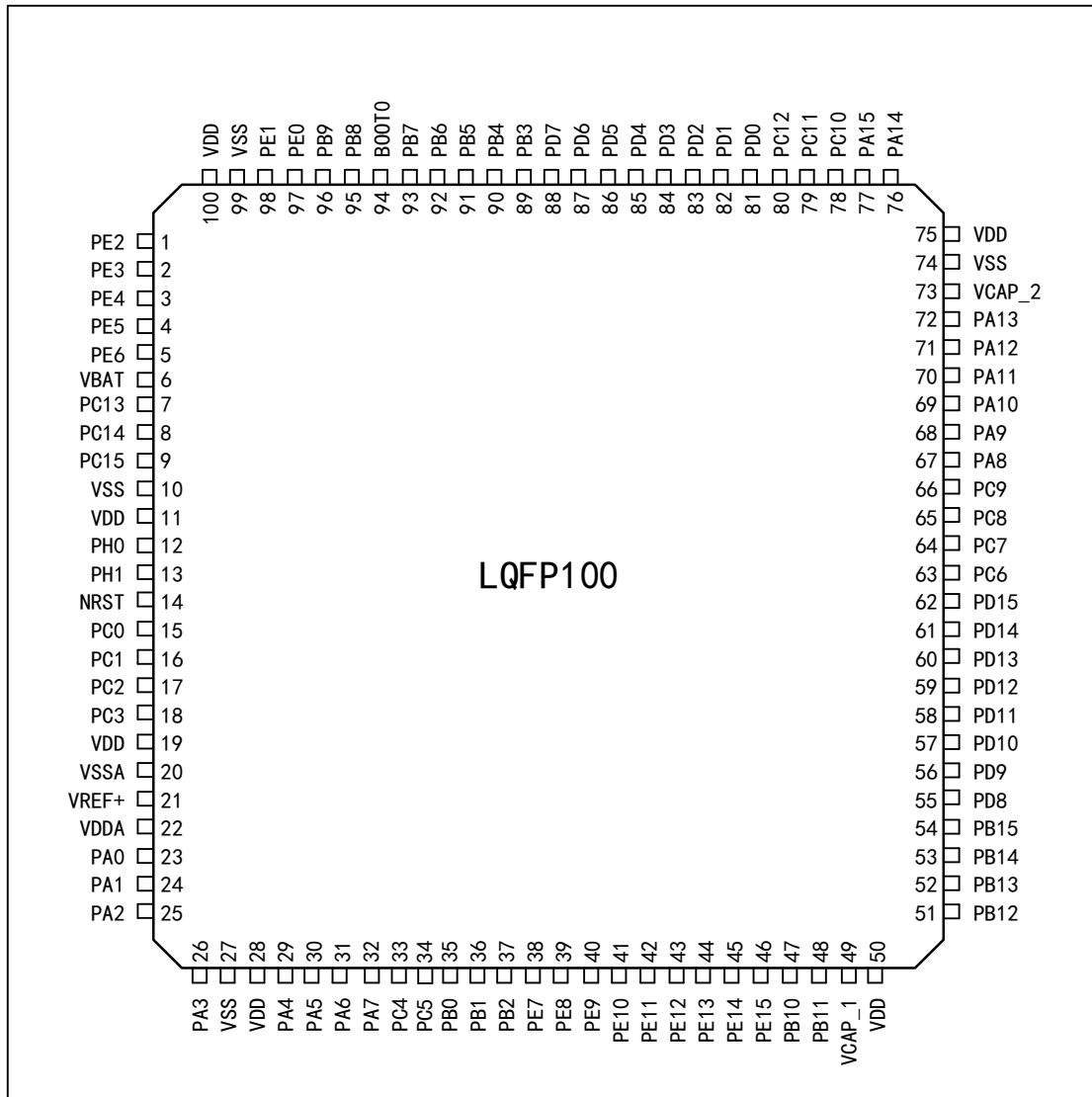
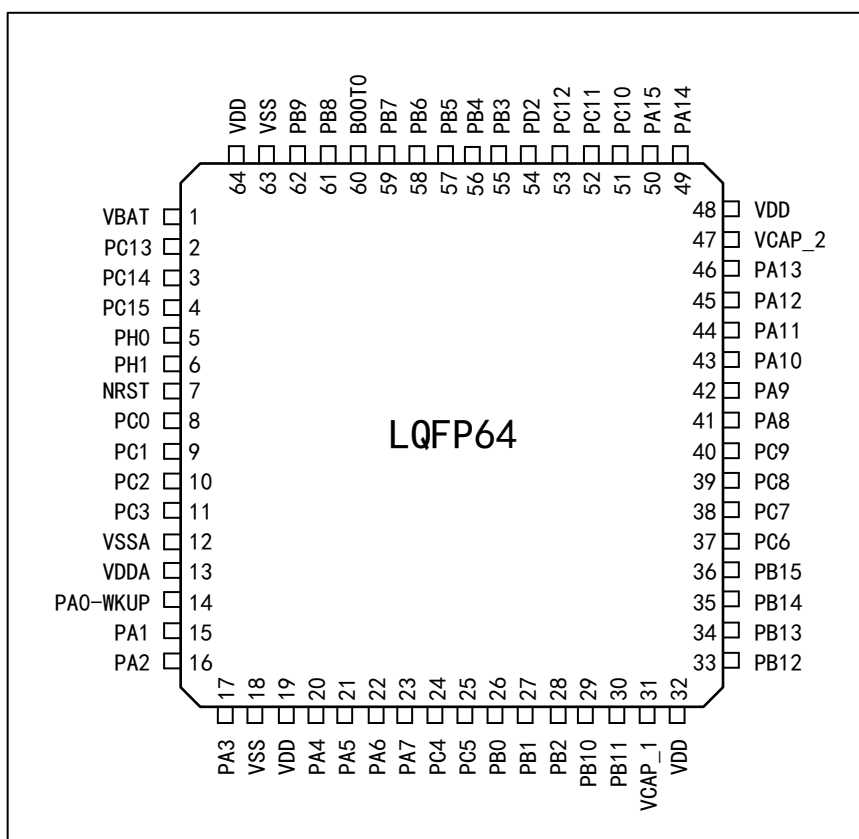

Figure 4 Distribution Diagram of APM32F405xG 407xExG Series LQFP64 Pins



3.2 Pin function description

Table 2 Legends/Abbreviations Used in Output Pin Table

Name	Abbreviation	Definition
Pin name	Unless otherwise specified in parentheses below the pin name, the pin functions during and after reset are the same as the actual pin name	
Pin type	P	Power pin
	I	Only input pin
	I/O	I/O pin
I/O structure	5T	FT I/O
	STDA	3.3V standard I/O, directly connected to ADC
	STD	3.3V standard I/O
	B	Dedicated Boot0 pin
	RST	Bidirectional reset pin with built-in pull-up resistor
Notes	Unless otherwise specified in the notes, all I/O is set as floating input during and after reset	
Pin function	Default multiplexing function	Function directly selected/enabled through peripheral register

Name	Abbreviation	Definition
Redefining function		Select this function through AFIO remapping register

Table 3 Description of APM32F405xG 407xExG by Pin Number

Name (Function after reset)	Type	Structure	Multiplexing function	Additional function	LQFP 64	LQFP 100	LQFP 144	LQFP 176
PE2	I/O	5T	TRACECK, SMC_A23, ETH_MII_TXD3, EVENTOUT	-	-	1	1	1
PE3	I/O	5T	TRACED0, SMC_A19, EVENTOUT	-	-	2	2	2
PE4	I/O	5T	TRACED1, SMC_A20, DCI_D4, EVENTOUT	-	-	3	3	3
PE5	I/O	5T	TRACED2, SMC_A21, TMR9_CH1, DCI_D6, EVENTOUT	-	-	4	4	4
PE6	I/O	5T	TRACED3, SMC_A22, TMR9_CH2, DCI_D7, EVENTOUT	-	-	5	5	5
VBAT	P	-	-	-	1	6	6	6
PI8	I/O	5T	EVENTOUT, DMC_CAS	RTC_TAMP1, RTC_TAMP2, RTC_TS	-	-	-	7
PC13	I/O	5T	EVENTOUT	RTC_OUT, RTC_TAMP1, RTC_TS	2	7	7	8
PC14- OSC32_IN (PC14)	I/O	5T	EVENTOUT	OSC32_IN	3	8	8	9
PC15- OSC32_OUT (PC15)	I/O	5T	EVENTOUT	OSC32_OUT	4	9	9	10
PI9	I/O	5T	CAN1_RX, EVENTOUT, DMC_RAS	-	-	-	-	11
PI10	I/O	5T	ETH_MII_RX_ER,	-	-	-	-	12

Name (Function after reset)	Type	Structure	Multiplexing function	Additional function	LQFP 64	LQFP 100	LQFP 144	LQFP 176
			EVENTOUT, DMC_CS					
PI11	I/O	5T	OTG_HS_ULPI_DIR, EVENTOUT, DMC_BA	-	-	-	-	13
VSS	P	-	-	-	-	-	-	14
VDD	P	-	-	-	-	-	-	15
PF0	I/O	5T	SMC_A0, DMC_A10, I2C2_SDA, EVENTOUT	-	-	-	10	16
PF1	I/O	5T	SMC_A1, DMC_A0, I2C2_SCL, EVENTOUT	-	-	-	11	17
PF2	I/O	5T	SMC_A2, DMC_A1, I2C2_SMBAL, EVENTOUT	-	-	-	12	18
PF3	I/O	5T	SMC_A3, DMC_A2, EVENTOUT	ADC3_IN9	-	-	13	19
PF4	I/O	5T	SMC_A4, DMC_A3, EVENTOUT	ADC3_IN14	-	-	14	20
PF5	I/O	5T	SMC_A5, EVENTOUT	ADC3_IN15	-	-	15	21
VSS	P	-	-	-	-	10	16	22
VDD	P	-	-	-	-	11	17	23
PF6	I/O	5T	TMR10_CH1, SMC_NIORD, DMC_A4, EVENTOUT	ADC3_IN4	-	-	18	24
PF7	I/O	5T	TMR11_CH1, SMC_NREG, DMC_A5, EVENTOUT	ADC3_IN5	-	-	19	25
PF8	I/O	5T	TMR13_CH1, SMC_NIOWR,	ADC3_IN6	-	-	20	26

Name (Function after reset)	Type	Structure	Multiplexing function	Additional function	LQFP 64	LQFP 100	LQFP 144	LQFP 176
			DMC_A6, EVENTOUT					
PF9	I/O	5T	TMR14_CH1, SMC_CD, DMC_A7 EVENTOUT	ADC3_IN7	-	-	21	27
PF10	I/O	5T	SMC_INTR, DMC_A8 EVENTOUT	ADC3_IN8	-	-	22	28
PH0-OSC_IN (PH0)	I/O	5T	EVENTOUT	OSC_IN	5	12	23	29
PH1-OSC_OUT (PH1)	I/O	5T	EVENTOUT	OSC_OUT	6	13	24	30
NRST	I/O	RST	-	-	7	14	25	31
PC0	I/O	5T	OTG_HS_ULPI_STP, EVENTOUT	ADC123_IN10	8	15	26	32
PC1	I/O	5T	ETH_MDC, EVENTOUT	ADC123_IN11	9	16	27	33
PC2	I/O	5T	SPI2_MISO, OTG_HS_ULPI_DIR, ETH_MII_TXD2, I2S2ext_SD, EVENTOUT	ADC123_IN12	10	17	28	34
PC3	I/O	5T	SPI2_MOSI, I2S2_SD, OTG_HS_ULPI_NXT, ETH_MII_TX_CLK, EVENTOUT	ADC123_IN13	11	18	29	35
VDD	P	-	-	-	-	19	30	36
VSSA	P	-	-	-	12	20	31	37
VREF+	P	-	-	-	-	21	32	38
VDDA	P	-	-	-	13	22	33	39
PA0-WKUP (PA0)	I/O	5T	USART2_CTS, UART4_TX, ETH_MII_CRS, TMR2_CH1_ETR, TMR5_CH1, TMR8_ETR, EVENTOUT	WKUP, ADC123_IN0	14	23	34	40

Name (Function after reset)	Type	Structure	Multiplexing function	Additional function	LQFP 64	LQFP 100	LQFP 144	LQFP 176
PA1	I/O	5T	USART2_RTS, UART4_RX, ETH_RMII_REF_CLK, ETH_MII_RX_CLK, TMR5_CH2, TMR2_CH2, EVENTOUT	ADC123_IN1	15	24	35	41
PA2	I/O	5T	USART2_TX, TMR5_CH3, TMR9_CH1, TMR2_CH3, ETH_MDIO, EVENTOUT	ADC123_IN2	16	25	36	42
PH2	I/O	5T	ETH_MII_CRCS, EVENTOUT	-	-	-	-	43
PH3	I/O	5T	ETH_MII_COL, EVENTOUT, DMC_A9	-	-	-	-	44
PH4	I/O	5T	I2C2_SCL, OTG_HS_ULPI_NXT, EVENTOUT	-	-	-	-	45
PH5	I/O	5T	I2C2_SDA, EVENTOUT DMC_CKE	-	-	-	-	46
PA3	I/O	5T	USART2_RX, TMR5_CH4, TMR9_CH2, TMR2_CH4, OTG_HS_ULPI_D0, ETH_MII_COL, EVENTOUT,	ADC123_IN3	17	26	37	47
VSS	P	-	-	-	18	27	38	-
BYPASS_REG	I	5T	-	-	-	-	-	48
VDD	P	-	-	-	19	28	39	49
PA4	I/O	STDA	SPI1_NSS, SPI3_NSS, USART2_CK, DCI_HSYNC, OTG_HS_SOF, I2S3_WS,	DAC_OUT1, ADC12_IN4	20	29	40	50

Name (Function after reset)	Type	Structure	Multiplexing function	Additional function	LQFP 64	LQFP 100	LQFP 144	LQFP 176
			EVENTOUT					
PA5	I/O	STDA	SPI1_SCK, OTG_HS_ULPI_CK, TMR2_CH1_ETR, TMR8_CH1N, EVENTOUT	DAC_OUT2, ADC12_IN5	21	30	41	51
PA6	I/O	5T	SPI1_MISO, TMR8_BKIN, TMR13_CH1, DCI_PIXCLK, TMR3_CH1, TMR1_BKIN, EVENTOUT	ADC12_IN6	22	31	42	52
PA7	I/O	5T	SPI1_MOSI, TMR8_CH1N, TMR14_CH1, TMR3_CH2, ETH_MII_RX_DV, TMR1_CH1N, ETH_RMII_CRD_DV, EVENTOUT	ADC12_IN7	23	32	43	53
PC4	I/O	5T	ETH_RMII_RX_D0, ETH_MII_RX_D0, EVENTOUT	ADC12_IN14	24	33	44	54
PC5	I/O	5T	ETH_RMII_RX_D1, ETH_MII_RX_D1, EVENTOUT	ADC12_IN15	25	34	45	55
PB0	I/O	5T	TMR3_CH3 TMR8_CH2N, OTG_HS_ULPI_D1, ETH_MII_RXD2, TMR1_CH2N, EVENTOUT	ADC12_IN8	26	35	46	56
PB1	I/O	5T	TMR3_CH4 TMR8_CH3N, OTG_HS_ULPI_D2, ETH_MII_RXD3, TMR1_CH3N, EVENTOUT	ADC12_IN9	27	36	47	57
PB2-BOOT1	I/O	5T	EVENTOUT	-	28	37	48	58

Name (Function after reset)	Type	Structure	Multiplexing function	Additional function	LQFP 64	LQFP 100	LQFP 144	LQFP 176
(PB2)								
PF11	I/O	5T	DCI_D12, EVENTOUT, DMC_UDQM	-	-	-	49	59
PF12	I/O	5T	SMC_A6, EVENTOUT	-	-	-	50	60
VSS	P	-	-	-	-	-	51	61
VDD	P	-	-	-	-	-	52	62
PF13	I/O	5T	SMC_A7, EVENTOUT	-	-	-	53	63
PF14	I/O	5T	SMC_A8, EVENTOUT	-	-	-	54	64
PF15	I/O	5T	SMC_A9, EVENTOUT	-	-	-	55	65
PG0	I/O	5T	SMC_A10, EVENTOUT	-	-	-	56	66
PG1	I/O	5T	SMC_A11, DMC_CK, EVENTOUT	-	-	-	57	67
PE7	I/O	5T	SMC_D4, TMR1_ETR, EVENTOUT	-	-	38	58	68
PE8	I/O	5T	SMC_D5, TMR1_CH1N, EVENTOUT	-	-	39	59	69
PE9	I/O	5T	SMC_D6, TMR1_CH1, EVENTOUT	-	-	40	60	70
VSS	P	-	-	-	-	-	61	71
VDD	P	-	-	-	-	-	62	72
PE10	I/O	5T	SMC_D7, TMR1_CH2N, EVENTOUT	-	-	41	63	73
PE11	I/O	5T	SMC_D8, TMR1_CH2, EVENTOUT	-	-	42	64	74
PE12	I/O	5T	SMC_D9, TMR1_CH3N, EVENTOUT	-	-	43	65	75

Name (Function after reset)	Type	Structure	Multiplexing function	Additional function	LQFP 64	LQFP 100	LQFP 144	LQFP 176
PE13	I/O	5T	SMC_D10, TMR1_CH3, EVENTOUT	-	-	44	66	76
PE14	I/O	5T	SMC_D11, TMR1_CH4, EVENTOUT	-	-	45	67	77
PE15	I/O	5T	SMC_D12, TMR1_BKIN, EVENTOUT	-	-	46	68	78
PB10	I/O	5T	SPI2_SCK, I2S2_CK, I2C2_SCL, USART3_TX, OTG_HS_ULPI_D3, ETH_MII_RX_ER, TMR2_CH3, EVENTOUT	-	29	47	69	79
PB11	I/O	5T	I2C2_SDA, USART3_RX, OTG_HS_ULPI_D4, ETH_RMII_TX_EN, ETH_MII_TX_EN, TMR2_CH4, EVENTOUT	-	30	48	70	80
VCAP_1	P	-	-	-	31	49	71	81
VDD	P	-	-	-	32	50	72	82
PH6	I/O	5T	I2C2_SMBAL, TMR12_CH1, ETH_MII_RXD2, EVENTOUT	-	-	-	-	83
PH7	I/O	5T	I2C3_SCL, ETH_MII_RXD3, EVENTOUT	-	-	-	-	84
PH8	I/O	5T	I2C3_SDA, DCI_HSYNC, EVENTOUT, DMC_DQ8	-	-	-	-	85
PH9	I/O	5T	I2C3_SMBAL, TMR12_CH2, DCI_D0,	-	-	-	-	86

Name (Function after reset)	Type	Structure	Multiplexing function	Additional function	LQFP 64	LQFP 100	LQFP 144	LQFP 176
			EVENTOUT					
PH10	I/O	5T	TMR5_CH1, DCI_D1, EVENTOUT, DMC_DQ9	-	-	-	-	87
PH11	I/O	5T	TMR5_CH2, DCI_D2, EVENTOUT	-	-	-	-	88
PH12	I/O	5T	TMR5_CH3, DCI_D3, EVENTOUT	-	-	-	-	89
VSS	P	-	-	-	-	-	-	90
VDD	P	-	-	-	-	-	-	91
PB12	I/O	5T	SPI2_NSS, I2S2_WS, I2C2_SMBAl, USART3_CK, TMR1_BKIN, CAN2_RX, OTG_HS_ULPI_D5, ETH_RMII_TXD0, ETH_MII_TXD0, OTG_HS_ID, EVENTOUT	-	33	51	73	92
PB13	I/O	5T	SPI2_SCK, I2S2_CK, USART3_CTS, TMR1_CH1N, CAN2_TX, OTG_HS_ULPI_D6, ETH_RMII_TXD1, ETH_MII_TXD1, EVENTOUT	OTG_HS_VBUS	34	52	74	93
PB14	I/O	5T	SPI2_MISO, TMR1_CH2N, TMR12_CH1, OTG_HS_DM, USART3_RTS, TMR8_CH2N, I2S2ext_SD,	-	35	53	75	94

Name (Function after reset)	Type	Structure	Multiplexing function	Additional function	LQFP 64	LQFP 100	LQFP 144	LQFP 176
			EVENTOUT					
PB15	I/O	5T	SPI2_MOSI, I2S2_SD, TMR1_CH3N, TMR8_CH3N TMR12_CH2, OTG_HS_DP, EVENTOUT	RTC_REFIN	36	54	76	95
PD8	I/O	5T	SMC_D13, USART3_TX, EVENTOUT	-	-	55	77	96
PD9	I/O	5T	SMC_D14, USART3_RX, EVENTOUT	-	-	56	78	97
PD10	I/O	5T	SMC_D15, DMC_DQ10 USART3_CK, EVENTOUT	-	-	57	79	98
PD11	I/O	5T	SMC_CLE, SMC_A16, USART3_CTS, EVENTOUT	-	-	58	80	99
PD12	I/O	5T	SMC_ALE, SMC_A17, DMC_DQ11, TMR4_CH1, USART3_RTS, EVENTOUT	-	-	59	81	100
PD13	I/O	5T	SMC_A18, DMC_DQ12 TMR4_CH2, EVENTOUT	-	-	60	82	101
VSS	P	-	-	-	-	-	83	102
VDD	P	-	-	-	-	-	84	103
PD14	I/O	5T	SMC_D0, DMC_DQ13, TMR4_CH3, EVENTOUT	-	-	61	85	104
PD15	I/O	5T	SMC_D1,	-	-	62	86	105

Name (Function after reset)	Type	Structure	Multiplexing function	Additional function	LQFP 64	LQFP 100	LQFP 144	LQFP 176
			DMC_DQ14, TMR4_CH4, EVENTOUT					
PG2	I/O	5T	SMC_A12, DMC_DQ15, EVENTOUT	-	-	-	87	106
PG3	I/O	5T	SMC_A13, DMC_DQ0, EVENTOUT	-	-	-	88	107
PG4	I/O	5T	SMC_A14, DMC_DQ1, EVENTOUT	-	-	-	89	108
PG5	I/O	5T	SMC_A15, DMC_DQ2, EVENTOUT	-	-	-	90	109
PG6	I/O	5T	SMC_INT2, DMC_DQ3 EVENTOUT	-	-	-	91	110
PG7	I/O	5T	SMC_INT3, USART6_CK, EVENTOUT	-	-	-	92	111
PG8	I/O	5T	DMC_DQ4 USART6_RTS, ETH_PPS_OUT, EVENTOUT	-	-	-	93	112
VSS	P	-	-	-	-	-	94	113
VDD	P	-	-	-	-	-	95	114
PC6	I/O	5T	I2S2_MCK, TMR8_CH1, SDIO_D6, USART6_TX, DCI_D0, TMR3_CH1, EVENTOUT	-	37	63	96	115
PC7	I/O	5T	I2S3_MCK, TMR8_CH2, SDIO_D7, USART6_RX, DCI_D1, TMR3_CH2,	-	38	64	97	116

Name (Function after reset)	Type	Structure	Multiplexing function	Additional function	LQFP 64	LQFP 100	LQFP 144	LQFP 176
			EVENTOUT					
PC8	I/O	5T	TMR8_CH3, SDIO_D0, TMR3_CH3, USART6_CK, DCI_D2, EVENTOUT	-	39	65	98	117
PC9	I/O	5T	I2S_CKIN, MCO2, TMR8_CH4, SDIO_D1, I2C3_SDA, DCI_D3, TMR3_CH4, EVENTOUT	-	40	66	99	118
PA8	I/O	5T	USART1_CK, TMR1_CH1, MCO, I2C3_SCL, OTG_FS_SOF, EVENTOUT	-	41	67	100	119
PA9	I/O	5T	USART1_TX, TMR1_CH2, I2C3_SMBAL, DCI_D0, EVENTOUT	OTG_FS_VBUS	42	68	101	120
PA10	I/O	5T	USART1_RX, TMR1_CH3, OTG_FS_ID, DCI_D1, EVENTOUT	-	43	69	102	121
PA11	I/O	5T	USART1_CTS, CAN1_RX, TMR1_CH4, OTG_FS_DM, EVENTOUT	-	44	70	103	122
PA12	I/O	5T	USART1_RTS, CAN1_TX, TMR1_ETR, OTG_FS_DP,	-	45	71	104	123

Name (Function after reset)	Type	Structure	Multiplexing function	Additional function	LQFP 64	LQFP 100	LQFP 144	LQFP 176
			EVENTOUT					
PA13 (JTMS-SWDIO)	I/O	5T	JTMS-SWDIO, EVENTOUT	PA13	46	72	105	124
VCAP_2	P	-	-	-	47	73	106	125
VSS	P	-	-	-	-	74	107	126
VDD	P	-	-	-	48	75	108	127
PH13	I/O	5T	TMR8_CH1N, CAN1_TX, EVENTOUT, DMC_DQ5	-	-	-	-	128
PH14	I/O	5T	TMR8_CH2N, DCI_D4, EVENTOUT	-	-	-	-	129
PH15	I/O	5T	TMR8_CH3N, DCI_D11, EVENTOUT, DMC_DQ6	-	-	-	-	130
PI0	I/O	5T	TMR5_CH4, SPI2_NSS, I2S2_WS, DCI_D13, EVENTOUT	-	-	-	-	131
PI1	I/O	5T	SPI2_SCK, I2S2_CK, DCI_D8, EVENTOUT	-	-	-	-	132
PI2	I/O	5T	TMR8_CH4, SPI2_MISO, DCI_D9, I2S2ext_SD, EVENTOUT	-	-	-	-	133
PI3	I/O	5T	TMR8_ETR, SPI2_MOSI, I2S2_SD, DCI_D10, EVENTOUT, DMC_DQ7	-	-	-	-	134
VSS	P	-	-	-	-	-	-	135
VDD	P	-	-	-	-	-	-	136

Name (Function after reset)	Type	Structure	Multiplexing function	Additional function	LQFP 64	LQFP 100	LQFP 144	LQFP 176
PA14 (JTCK/SWCLK)	I/O	5T	JTCK-SWCLK, EVENTOUT	-	49	76	109	137
PA15 (JTDI)	I/O	5T	JTDI, SPI3_NSS, I2S3_WS, TMR2_CH1_ETR, SPI1_NSS, EVENTOUT	-	50	77	110	138
PC10	I/O	5T	SPI3_SCK, I2S3_CK, UART4_TX, SDIO_D2, DCI_D8, USART3_TX, EVENTOUT	-	51	78	111	139
PC11	I/O	5T	UART4_RX, SPI3_MISO, SDIO_D3, DCI_D4, USART3_RX, I2S3ext_SD, EVENTOUT	-	52	79	112	140
PC12	I/O	5T	UART5_TX, SDIO_CK, DCI_D9, SPI3_MOSI, I2S3_SD, USART3_CK, EVENTOUT	-	53	80	113	141
PD0	I/O	5T	SMC_D2, CAN1_RX, EVENTOUT	-	-	81	114	142
PD1	I/O	5T	SMC_D3, CAN1_TX, EVENTOUT	-	-	82	115	143
PD2	I/O	5T	TMR3_ETR, UART5_RX, SDIO_CMD, DCI_D11, EVENTOUT	-	54	83	116	144

Name (Function after reset)	Type	Structure	Multiplexing function	Additional function	LQFP 64	LQFP 100	LQFP 144	LQFP 176
PD3	I/O	5T	SMC_CLK, USART2_CTS, EVENTOUT	-	-	84	117	145
PD4	I/O	5T	SMC_NOE, USART2_RTS, EVENTOUT	-	-	85	118	146
PD5	I/O	5T	SMC_NWE, USART2_TX, EVENTOUT	-	-	86	119	147
VSS	P	-	-	-	-	-	120	148
VDD	P	-	-	-	-	-	121	149
PD6	I/O	5T	SMC_NWAIT, USART2_RX, EVENTOUT	-	-	87	122	150
PD7	I/O	5T	SMC_NE1, SMC_NCE2, USART2_CK, EVENTOUT	-	-	88	123	151
PG9	I/O	5T	SMC_NE2, SMC_NCE3, USART6_RX, EVENTOUT	-	-	-	124	152
PG10	I/O	5T	SMC_NCE4_1, SMC_NE3, EVENTOUT	-	-	-	125	153
PG11	I/O	5T	SMC_NCE4_2, ETH_MII_TX_EN, ETH_RMII_TX_EN, EVENTOUT	-	-	-	126	154
PG12	I/O	5T	SMC_NE4, USART6_RTS, EVENTOUT	-	-	-	127	155
PG13	I/O	5T	SMC_A24, USART6_CTS, ETH_MII_TXD0, ETH_RMII_TXD0, EVENTOUT	-	-	-	128	156
PG14	I/O	5T	SMC_A25, USART6_TX, ETH_MII_TXD1,	-	-	-	129	157

Name (Function after reset)	Type	Structure	Multiplexing function	Additional function	LQFP 64	LQFP 100	LQFP 144	LQFP 176
			ETH_RMII_TXD1, EVENTOUT					
VSS	P	-	-	-	-	-	130	158
VDD	P	-	-	-	-	-	131	159
PG15	I/O	5T	DMC_LDQM, USART6_CTS, DCI_D13, EVENTOUT	-	-	-	132	160
PB3 (JTDO/TRACESWO)	I/O	5T	JTDO, TRACESWO, SPI3_SCK, I2S3_CK, TMR2_CH2, SPI1_SCK, EVENTOUT	-	55	89	133	161
PB4 (NJTRST)	I/O	5T	NJTRST, SPI3_MISO, TMR3_CH1, SPI1_MISO, I2S3ext_SD, EVENTOUT	-	56	90	134	162
PB5	I/O	5T	I2C1_SMBAL, CAN2_RX, OTG_HS_ULPI_D7, ETH_PPS_OUT, TMR3_CH2, SPI1_MOSI, SPI3_MOSI, DCI_D10, I2S3_SD, EVENTOUT	-	57	91	135	163
PB6	I/O	5T	I2C1_SCL, TMR4_CH1, CAN2_TX, DCI_D5, USART1_TX, EVENTOUT	-	58	92	136	164
PB7	I/O	5T	I2C1_SDA, SMC_NL, DCI_VSYNC,	-	59	93	137	165

Name (Function after reset)	Type	Structure	Multiplexing function	Additional function	LQFP 64	LQFP 100	LQFP 144	LQFP 176
			USART1_RX, TMR4_CH2, EVENTOUT					
BOOT0	I	B	-	VPP	60	94	138	166
PB8	I/O	5T	TMR4_CH3, SDIO_D4, TMR10_CH1, DCI_D6, ETH_MII_TXD3, I2C1_SCL, CAN1_RX, EVENTOUT	-	61	95	139	167
PB9	I/O	5T	SPI2_NSS, I2S2_WS, TMR4_CH4, TMR11_CH1, SDIO_D5, DCI_D7, I2C1_SDA, CAN1_TX, EVENTOUT	-	62	96	140	168
PE0	I/O	5T	TMR4_ETR, SMC_NBL0, DCI_D2, EVENTOUT	-	-	97	141	169
PE1	I/O	5T	SMC_NBL1, DCI_D3, EVENTOUT	-	-	98	142	170
VSS	P	-	-	-	63	99	-	-
PDR_ON	I	5T	-	-	-	-	143	171
VDD	P	-	-	-	64	100	144	172
PI4	I/O	5T	TMR8_BKIN, DCI_D5, EVENTOUT	-	-	-	-	173
PI5	I/O	5T	TMR8_CH1, DCI_VSYNC, EVENTOUT	-	-	-	-	174
PI6	I/O	5T	TMR8_CH2, DCI_D6,	-	-	-	-	175

Name (Function after reset)	Type	Structure	Multiplexing function	Additional function	LQFP 64	LQFP 100	LQFP 144	LQFP 176
			EVENTOUT					
PI7	I/O	5T	TMR8_CH3, DCI_D7, EVENTOUT, DMC_WE	-	-	-	-	176

Note:

(1) PC13, PC14 and PC15 are powered through the power switch. Since the switch only sinks limited current (3mA), the use of GPIO from PC13 to PC15 in output mode is limited:

- ① The speed shall not exceed 2MHz when the heavy load is 30pF;
- ② Not used for current source (e.g. driving LED).

3.3 GPIO Multiplexing Function Configuration

Table 4 GPIOA Multiplexing Function Configuration

Port	AF0	AF1	AF2	AF3	AF4	AF5	AF6	AF7	AF8	AF9	AF10	AF11	AF12	AF13	AF14	AF15
PA0	-	TMR2_C H1_ETR	TMR5 _CH1	TMR8_ ETR	-	-	-	USART 2_CTS	UART 4_TX	-	-	ETH_MII_C RS	-	-	-	EVEN TOUT
PA1	-	TMR2_C H2	TMR5 _CH2	-	-	-	-	USART 2_RTS	UART 4_RX	-	-	ETH_MII_R X_CLK ETH_RMII_ REF_CLK	-	-	-	EVEN TOUT
PA2	-	TMR2_C H3	TMR5 _CH3	TMR9_ CH1	-	-	-	USART 2_TX	-	-	-	ETH_MDIO	-	-	-	EVEN TOUT
PA3	-	TMR2_C H4	TMR5 _CH4	TMR9_ CH2	-	-	-	USART 2_RX	-	-	OTG_HS_ ULPI_D0	ETH_MII_C OL	DMC_C KE	-	-	EVEN TOUT
PA4	-	-	-	-	-	SPI1_ NSS	SPI3_ NSS I2S3_ WS	USART 2_CK	-	-	-	-	OTG_H S_SOF	DCI_H SYNC	-	EVEN TOUT
PA5	-	TMR2_C H1_ETR	-	TMR8_ CH1N	-	SPI1_ SCK	-	-	-	-	OTG_HS_ ULPI_CK	-	-	-	-	EVEN TOUT
PA6	-	TMR1_B KIN	TMR3 _CH1	TMR8_ BKIN	-	SPI1_ MISO	-	-	-	TMR13 _CH1	-	-	-	DCI_PI XCK	-	EVEN TOUT
PA7	-	TMR1_C H1N	TMR3 _CH2	TMR8_ CH1N	-	SPI1_ MOSI	-	-	-	TMR14 _CH1	-	ETH_MII_R X_DV ETH_RMII_ CRS_DV	-	-	-	EVEN TOUT

Port	AF0	AF1	AF2	AF3	AF4	AF5	AF6	AF7	AF8	AF9	AF10	AF11	AF12	AF13	AF14	AF15
PA8	MCO1	TMR1_C H1	-	-	I2C3_ SCL	-	-	USART 1_CK	-	-	OTG_FS_ SOF	-	-	-	-	EVEN TOUT
PA9	-	TMR1_C H2	-	-	I2C3_ SMBA	-	-	USART 1_TX	-	-	-	-	-	DCI_D 0	-	EVEN TOUT
PA10	-	TMR1_C H3	-	-	-	-	-	USART 1_RX	-	-	OTG_FS_I D	-	-	DCI_D 1	-	EVEN TOUT
PA11	-	TMR1_C H4	-	-	-	-	-	USART 1_CTS	-	CAN1_ RX	OTG_FS_ DM	-	-	-	-	EVEN TOUT
PA12	-	TMR1_E TR	-	-	-	-	-	USART 1_RTS	-	CAN1_ TX	OTG_FS_ DP	-	-	-	-	EVEN TOUT
PA13	JTMS_ SWDIO	-	-	-	-	-	-	-	-	-	-	-	-	-	-	EVEN TOUT
PA14	JTCK_ S WCLK	-	-	-	-	-	-	-	-	-	-	-	-	-	-	EVEN TOUT
PA15	JTDI	TMR2_C H1 TMR2_E TR	-	-	-	SPI1_ NSS	SPI3_ NSS I2C3_ WS	-	-	-	-	-	-	-	-	EVEN TOUT

Table 5 GPIOB Multiplexing Function Configuration

Port	AF0	AF1	AF2	AF3	AF4	AF5	AF6	AF7	AF8	AF9	AF10	AF11	AF12	AF13	AF14	AF15
PB0	-	TMR1_CH2N	TMR3_CH3	TMR8_CH2N	-	-	-	-	-	-	OTG_HS_ULPI_D1	ETH_MII_RXD2	-	-	-	EVEN TOUT
PB1	-	TMR1_CH3N	TMR3_CH4	TMR8_CH3N	-	-	-	-	-	-	OTG_HS_ULPI_D2	ETH_MII_RXD3	-	-	-	EVEN TOUT
PB2	-	-	-	-	-	-	-	-	-	-	-	-	-	-	-	EVEN TOUT
PB3	JTDO/TRACESWO	TMR2_CH2	-	-	-	SPI1_SCK	SPI3_SCK I2S3_CK	-	-	-	-	-	-	-	-	EVEN TOUT
PB4	NJTRST	-	TMR3_CH1	-	-	SPI1_MISO	SPI3_MISO	I2S3ext_SD	-	-	-	-	-	-	-	EVEN TOUT
PB5	-	-	TMR3_CH2	-	I2C1_SMBA	SPI1_MOSI	SPI3_MOSI I2S3_SD	-	-	CAN2_RX	OTG_HS_ULPI_D7	ETH_PP_S_OUT	-	DCI_D10	-	EVEN TOUT
PB6	-	-	TMR4_CH1	-	I2C1_SCL	-	-	USART1_TX	-	CAN2_TX	-	-	-	DCI_D5	-	EVEN TOUT
PB7	-	-	TMR4_CH2	-	I2C1_SDA	-	-	USART1_RX	-	-	-	-	SMC_NL	DCI_VSYNC	-	EVEN TOUT
PB8	-	-	TMR4_CH3	TMR10_CH1	I2C1_SCL	-	-	-	-	CAN1_RX	-	ETH_MII_TXD3	SDIO_D4	DCI_D6	-	EVEN TOUT
PB9	-	-	TMR4_CH4	TMR11_CH1	I2C1_SDA	SPI2_NSS I2S2_WS	-	-	-	CAN1_TX	-	-	SDIO_D5	DCI_D7	-	EVEN TOUT
PB10	-	TMR2_CH3	-	-	I2C2_SCL	SPI2_SCK I2S2_CK	-	USART3_TX	-	-	OTG_HS_ULPI_D3	ETH_MII_RX_ER	-	-	-	EVEN TOUT

Port	AF0	AF1	AF2	AF3	AF4	AF5	AF6	AF7	AF8	AF9	AF10	AF11	AF12	AF13	AF14	AF15
PB11	-	TMR2_CH4	-	-	I2C2_SDA	-	-	USART3_RX	-	-	OTG_HS_ULPI_D4	ETH_MII_TX_EN ETH_RMII_TX_EN	-	-	-	EVEN TOUT
PB12	-	TMR1_BKIN	-	-	I2C2_SMBA	SPI2_NSS I2S2_WS	-	USART3_CK	-	CAN2_RX	OTG_HS_ULPI_D5	ETH_RMII_TXD0 ETH_MII_TXD0	OTG_HS_ID	-	-	EVEN TOUT
PB13	-	TMR1_CH1N	-	-	-	SPI2_SCK I2S2_CK	-	USART3_CTS	-	CAN2_TX	OTG_HS_ULPI_D6	ETH_RMII_TXD1 ETH_MII_TXD1	-	-	-	EVEN TOUT
PB14	-	TMR1_CH2N	-	TMR8_CH2N	-	SPI2_MISO	I2S2ext_SD	USART3_RTS	-	TMR12_CH1	-	-	OTG_HS_DM	-	-	EVEN TOUT
PB15	RTC_REFIN	TMR1_CH3N	-	TMR8_CH3N	-	SPI2_MOSI I2S2_SD	-	-	-	TMR12_CH2	-	-	OTG_HS_DP	-	-	EVEN TOUT

Table 6 GPIOC Multiplexing Function Configuration

Port	AF0	AF1	AF2	AF3	AF4	AF5	AF6	AF7	AF8	AF9	AF10	AF11	AF12	AF13	AF14	AF15
PC0	-	-	-	-	-	-	-	-	-	-	OTG_HS_ULPI_STP	-	-	-	-	EVENT OUT
PC1	-	-	-	-	-	-	-	-	-	-	-	ETH_MDC	-	-	-	EVENT OUT
PC2	-	-	-	-	-	SPI2_MISO	I2S2ext_SD	-	-	-	OTG_HS_ULPI_DIR	ETH_MII_TXD2	-	-	-	EVENT OUT
PC3	-	-	-	-	-	SPI2_MOSI	I2S2_SD	-	-	-	OTG_HS_ULPI_NXT	ETH_MII_TX_CLK	-	-	-	EVENT OUT
PC4	-	-	-	-	-	-	-	-	-	-	-	ETH_MII_RXD0 ETH_RMII_RXD0	-	-	-	EVENT OUT
PC5	-	-	-	-	-	-	-	-	-	-	-	ETH_MII_RXD1 ETH_RMII_RXD1	-	-	-	EVENT OUT
PC6	-	-	TMR3_CH1	TMR8_CH1	-	I2S2_MCK	-	-	USART6_TX	-	-	-	SDIO_D6	DCI_D0	-	EVENT OUT
PC7	-	-	TMR3_CH2	TMR8_CH2	-	-	I2S3_MCK	-	USART6_RX	-	-	-	SDIO_D7	DCI_D1	-	EVENT OUT

Port	AF0	AF1	AF2	AF3	AF4	AF5	AF6	AF7	AF8	AF9	AF10	AF11	AF12	AF13	AF14	AF15
PC8	-	-	TMR3_CH3	TMR8_CH3	-	-	-	-	USART6_CK	-	-	-	SDIO_D0	DCI_D2	-	EVENT OUT
PC9	MC02	-	TMR3_CH4	TMR8_CH4	I2C3_SDA	I2S_CK1N	-	-	-	-	-	-	SDIO_D1	DCI_D3	-	EVENT OUT
PC10	-	-	-	-	-	-	SPI3_SCK/ I2S3_CK	USART3_TX/ UART4_TX	UART4_TX	-	-	-	SDIO_D2	DCI_D8	-	EVENT OUT
PC11	-	-	-	-	-	I2S3ext_SD	SPI3_MISO/ I2S3_SD	USART3_RX UART4_RX	UART4_RX	-	-	-	SDIO_D3	DCI_D4	-	EVENT OUT
PC12	-	-	-	-	-	-	SPI3_MOSI I2S3_SD	USART3_CK UART5_TX	UART5_TX	-	-	-	SDIO_CK	DCI_D9	-	EVENT OUT
PC13	-	-	-	-	-	-	-	-	-	-	-	-	-	-	-	EVENT OUT
PC14	-	-	-	-	-	-	-	-	-	-	-	-	-	-	-	EVENT OUT
PC15	-	-	-	-	-	-	-	-	-	-	-	-	-	-	-	EVENT OUT

Table 7 GPIOD Multiplexing Function Configuration

Port	AF0	AF1	AF2	AF3	AF4	AF5	AF6	AF7	AF8	AF9	AF10	AF11	AF12	AF13	AF14	AF15
PD0	-	-	-	-	-	-	-	-	-	CAN1_RX	-	-	SMC_D2	-	-	EVENTOUT
PD1	-	-	-	-	-	-	-	-	-	CAN1_TX	-	-	SMC_D3	-	-	EVENTOUT
PD2	-	-	TMR3_ETR	-	-	-	-	-	UART5_RX	-	-	-	SDIO_CMD	DCI_D11	-	EVENTOUT
PD3	-	-	-	-	-	-	-	USART2_CS	-	-	-	-	SMC_CLK	-	-	EVENTOUT
PD4	-	-	-	-	-	-	-	USART2_RS	-	-	-	-	SMC_NOE	-	-	EVENTOUT
PD5	-	-	-	-	-	-	-	USART2_TX	-	-	-	-	SMC_NWE	-	-	EVENTOUT
PD6	-	-	-	-	-	-	-	USART2_RX	-	-	-	-	SMC_NWAIT	-	-	EVENTOUT
PD7	-	-	-	-	-	-	-	USART2_CK	-	-	-	-	SMC_NE1/SMC_NCE2	-	-	EVENTOUT
PD8	-	-	-	-	-	-	-	USART3_TX	-	-	-	-	SMC_D13	-	-	EVENTOUT

Port	AF0	AF1	AF2	AF3	AF4	AF5	AF6	AF7	AF8	AF9	AF10	AF11	AF12	AF13	AF14	AF15
PD9	-	-	-	-	-	-	-	USART3_RX	-	-	-	-	SMC_D14	-	-	EVENTOUT
PD10	-	-	-	-	-	-	-	USART3_CK	-	-	-	-	SMC_D15 DMC_DQ10	-	-	EVENTOUT
PD11	-	-	-	-	-	-	-	USART3_CTS	-	-	-	-	SMC_A16	-	-	EVENTOUT
PD12	-	-	TMR4_CH1	-	-	-	-	USART3_RTS	-	-	-	-	SMC_A17 DMC_DQ11	-	-	EVENTOUT
PD13	-	-	TMR4_CH2	-	-	-	-	-	-	-	-	-	SMC_A18 DMC_DQ12	-	-	EVENTOUT
PD14	-	-	TMR4_CH3	-	-	-	-	-	-	-	-	-	SMC_D0 DMC_DQ13	-	-	EVENTOUT
PD15	-	-	TMR4_CH4	-	-	-	-	-	-	-	-	-	SMC_D1 DMC_DQ14	-	-	EVENTOUT

Table 8 GPIOE Multiplexing Function Configuration

Port	AF0	AF1	AF2	AF3	AF4	AF5	AF6	AF7	AF8	AF9	AF10	AF11	AF12	AF13	AF14	AF15
PE0	-	-	TMR4_ET R	-	-	-	-	-	-	-	-	-	SMC_NBL 0	DCI_D 2	-	EVENTOU T
PE1	-	-	-	-	-	-	-	-	-	-	-	-	SMC_NBL 1	DCI_D 3	-	EVENTOU T
PE2	TRACECL K	-	-	-	-	-	-	-	-	-	-	ETH_MII_TXD 3	SMC_A23	-	-	EVENTOU T
PE3	TRACED0	-	-	-	-	-	-	-	-	-	-	-	SMC_A19	-	-	EVENTOU T
PE4	TRACED1	-	-	-	-	-	-	-	-	-	-	-	SMC_A20	DCI_D 4	-	EVENTOU T
PE5	TRACED2	-	-	TMR9_CH 1	-	-	-	-	-	-	-	-	SMC_A21	DCI_D 6	-	EVENTOU T
PE6	TRACED3	-	-	TMR9_CH 2	-	-	-	-	-	-	-	-	SMC_A22	DCI_D 7	-	EVENTOU T
PE7	-	TMR1_ETR	-	-	-	-	-	-	-	-	-	-	SMC_D4	-	-	EVENTOU T
PE8	-	TMR1_CH1 N	-	-	-	-	-	-	-	-	-	-	SMC_D5	-	-	EVENTOU T
PE9	-	TMR1_CH1	-	-	-	-	-	-	-	-	-	-	SMC_D6	-	-	EVENTOU T
PE10	-	TMR1_CH2 N	-	-	-	-	-	-	-	-	-	-	SMC_D7	-	-	EVENTOU T
PE11	-	TMR1_CH2	-	-	-	-	-	-	-	-	-	-	SMC_D8	-	-	EVENTOU T

Port	AF0	AF1	AF2	AF3	AF4	AF5	AF6	AF7	AF8	AF9	AF10	AF11	AF12	AF13	AF14	AF15
PE1 2	-	TMR1_CH3 N	-	-	-	-	-	-	-	-	-	-	SMC_D9	-	-	EVENTOU T
PE1 3	-	TMR1_CH3	-	-	-	-	-	-	-	-	-	-	SMC_D10	-	-	EVENTOU T
PE1 4	-	TMR1_CH4	-	-	-	-	-	-	-	-	-	-	SMC_D11	-	-	EVENTOU T
PE1 5	-	TMR1_BKI N	-	-	-	-	-	-	-	-	-	-	SMC_D12	-	-	EVENTOU T

Table 9 GPIOF Multiplexing Function Configuration

Port	AF0	AF1	AF2	AF3	AF4	AF5	AF6	AF7	AF8	AF9	AF10	AF11	AF12	AF13	AF14	AF15
PF0	-	-	-	-	I2C2_SDA	-	-	-	-	-	-	-	SMC_A0 DMC_A10	-	-	EVENTOUT
PF1	-	-	-	-	I2C2_SCL	-	-	-	-	-	-	-	SMC_A1 DMC_A0	-	-	EVENTOUT
PF2	-	-	-	-	I2C2_SMBA	-	-	-	-	-	-	-	SMC_A2 DMC_A1	-	-	EVENTOUT
PF3	-	-	-	-	-	-	-	-	-	-	-	-	SMC_A3 DMC_A2	-	-	EVENTOUT
PF4	-	-	-	-	-	-	-	-	-	-	-	-	SMC_A4 DMC_A3	-	-	EVENTOUT
PF5	-	-	-	-	-	-	-	-	-	-	-	-	SMC_A5	-	-	EVENTOUT
PF6	-	-	-	TMR10_CH1	-	-	-	-	-	-	-	-	SMC_NIORD DMC_A4	-	-	EVENTOUT
PF7	-	-	-	TMR11_CH1	-	-	-	-	-	-	-	-	SMC_NREG DMC_A5	-	-	EVENTOUT
PF8	-	-	-	-	-	-	-	-	-	TMR13_CH1	-	-	SMC_NIOWR DMC_A6	-	-	EVENTOUT
PF9	-	-	-	-	-	-	-	-	-	TMR14_CH1	-	-	SMC_CD DMC_A7	-	-	EVENTOUT
PF10	-	-	-	-	-	-	-	-	-	-	-	-	SMC_INTR DMC_A8	-	-	EVENTOUT
PF11	-	-	-	-	-	-	-	-	-	-	-	-	DMC_UDQM	DCI_D12	-	EVENTOUT
PF12	-	-	-	-	-	-	-	-	-	-	-	-	SMC_A6	-	-	EVENTOUT
PF13	-	-	-	-	-	-	-	-	-	-	-	-	SMC_A7	-	-	EVENTOUT
PF14	-	-	-	-	-	-	-	-	-	-	-	-	SMC_A8	-	-	EVENTOUT

Port	AF0	AF1	AF2	AF3	AF4	AF5	AF6	AF7	AF8	AF9	AF10	AF11	AF12	AF13	AF14	AF15
PF15	-	-	-	-	-	-	-	-	-	-	-	-	SMC_A9	-	-	EVENTOUT

Table 10 GPIOG Multiplexing Function Configuration

Port	AF 0	AF 1	AF 2	AF 3	AF 4	AF 5	AF 6	AF 7	AF8	AF 9	AF1 0	AF11	AF12	AF13	AF1 4	AF15
PG0	-	-	-	-	-	-	-	-	-	-	-	-	SMC_A10	-	-	EVENTOUT
PG1	-	-	-	-	-	-	-	-	-	-	-	-	SMC_A11 DMC_CK	-	-	EVENTOUT
PG2	-	-	-	-	-	-	-	-	-	-	-	-	SMC_A12 DMC_DQ15	-	-	EVENTOUT
PG3	-	-	-	-	-	-	-	-	-	-	-	-	SMC_A13 DMC_DQ0	-	-	EVENTOUT
PG4	-	-	-	-	-	-	-	-	-	-	-	-	SMC_A14 DMC_DQ1	-	-	EVENTOUT
PG5	-	-	-	-	-	-	-	-	-	-	-	-	SMC_A15 DMC_DQ2	-	-	EVENTOUT
PG6	-	-	-	-	-	-	-	-	-	-	-	-	SMC_INT2 DMC_DQ3	-	-	EVENTOUT
PG7	-	-	-	-	-	-	-	-	USART6_CK	-	-	-	SMC_INT3	-	-	EVENTOUT
PG8	-	-	-	-	-	-	-	-	USART6_RT S	-	-	ETH_PPS_OUT	DMC_DQ4	-	-	EVENTOUT
PG9	-	-	-	-	-	-	-	-	USART6_RX	-	-	-	SMC_NE2/SMC_NCE3	-	-	EVENTOUT
PG1 0	-	-	-	-	-	-	-	-	-	-	-	-	SMC_NCE4_1/SMC_N E3	-	-	EVENTOUT
PG1 1	-	-	-	-	-	-	-	-	-	-	-	ETH_MII_TX_EN ETH_RMII_TX_E N	SMC_NCE4_2	-	-	EVENTOUT

Port	AF 0	AF 1	AF 2	AF 3	AF 4	AF 5	AF 6	AF 7	AF8	AF 9	AF1 0	AF11	AF12	AF13	AF1 4	AF15
PG1 2	-	-	-	-	-	-	-	-	USART6_RT S	-	-	-	SMC_NE4	-	-	EVENTOU T
PG1 3	-	-	-	-	-	-	-	-	USART6_CT S	-	-	ETH_MII_TXD0 ETH_RMII_TXD0	SMC_A24	-	-	EVENTOU T
PG1 4	-	-	-	-	-	-	-	-	USART6_TX	-	-	ETH_MII_TXD1 ETH_RMII_TXD1	SMC_A25	-	-	EVENTOU T
PG1 5	-	-	-	-	-	-	-	-	USART6_CT S	-	-	-	DMC_LDQM	DCI_D1 3	-	EVENTOU T

Table 11 GPIOH Multiplexing Function Configuration

Port	AF0	AF1	AF2	AF3	AF4	AF5	AF6	AF7	AF8	AF9	AF10	AF11	AF12	AF13	AF14	AF15
PH0	-	-	-	-	-	-	-	-	-	-	-	-	-	-	-	EVENTO UT
PH1	-	-	-	-	-	-	-	-	-	-	-	-	-	-	-	EVENTO UT
PH2	-	-	-	-	-	-	-	-	-	-	-	ETH_MII_C RS	-	-	-	EVENTO UT
PH3	-	-	-	-	-	-	-	-	-	-	-	ETH_MII_C OL	DMC_A 9	-	-	EVENTO UT
PH4	-	-	-	-	I2C2_SC L	-	-	-	-	-	OTG_HS_ULPI_ NXT	-	-	-	-	EVENTO UT
PH5	-	-	-	-	I2C2_SD A	-	-	-	-	-	-	-	-	-	-	EVENTO UT
PH6	-	-	-	-	I2C2_SM BA	-	-	-	-	TMR12_C H1	-	ETH_MII_R XD2	-	-	-	EVENTO UT
PH7	-	-	-	-	I2C3_SC L	-	-	-	-	-	-	ETH_MII_R XD3	-	-	-	EVENTO UT
PH8	-	-	-	-	I2C3_SD A	-	-	-	-	-	-	-	DMC_D Q8	DCI_HSY NC	-	EVENTO UT
PH9	-	-	-	-	I2C3_SM BA	-	-	-	-	TMR12_C H2	-	-	-	DCI_D0	-	EVENTO UT
PH10	-	-	TMR5_C H1	-	-	-	-	-	-	-	-	-	DMC_D Q9	DCI_D1	-	EVENTO UT
PH11	-	-	TMR5_C H2	-	-	-	-	-	-	-	-	-	-	DCI_D2	-	EVENTO UT

Port	AF0	AF1	AF2	AF3	AF4	AF5	AF6	AF7	AF8	AF9	AF10	AF11	AF12	AF13	AF14	AF15
PH1 2	-	-	TMR5_C H3	-	-	-	-	-	-	-	-	-	-	DCI_D3	-	EVENTO UT
PH1 3	-	-	-	TMR8_CH 1N	-	-	-	-	-	CAN1_TX	-	-	DMC_D Q5	-	-	EVENTO UT
PH1 4	-	-	-	TMR8_CH 2N	-	-	-	-	-	-	-	-	-	DCI_D4	-	EVENTO UT
PH1 5	-	-	-	TMR8_CH 3N	-	-	-	-	-	-	-	-	DMC_D Q6	DCI_D11	-	EVENTO UT

Table 12 GPIOI Multiplexing Function Configuration

Port	AF0	AF1	AF2	AF3	AF4	AF5	AF6	AF7	AF8	AF9	AF10	AF11	AF12	AF13	AF14	AF15
PI0	-	-	TMR5_C H4	-	-	SPI2_NS S I2S2_W S	-	-	-	-	-	-	-	DCI_D13	-	EVENTO UT
PI1	-	-	-	-	-	SPI2_SC K I2S2_CK	-	-	-	-	-	-	-	DCI_D8	-	EVENTO UT
PI2	-	-	-	TMR8_C H4	-	SPI2_MI SO	I2S2ext_ SD	-	-	-	-	-	-	DCI_D9	-	EVENTO UT
PI3	-	-	-	TMR8_E TR	-	SPI2_M OSI I2S2_SD	-	-	-	-	-	-	DMC_D Q7	DCI_D10	-	EVENTO UT
PI4	-	-	-	TMR8_B KIN	-	-	-	-	-	-	-	-	-	DCI_D5	-	EVENTO UT
PI5	-	-	-	TMR8_C H1	-	-	-	-	-	-	-	-	-	DCI_VSY NC	-	EVENTO UT
PI6	-	-	-	TMR8_C H2	-	-	-	-	-	-	-	-	-	DCI_D6	-	EVENTO UT
PI7	-	-	-	TMR8_C H3	-	-	-	-	-	-	-	-	DMC_W E	DCI_D7	-	EVENTO UT
PI8	-	-	-	-	-	-	-	-	-	-	-	-	DMC_C AS	-	-	EVENTO UT
PI9	-	-	-	-	-	-	-	-	-	CAN1_ RX	-	-	DMC_R AS	-	-	EVENTO UT

Port	AF0	AF1	AF2	AF3	AF4	AF5	AF6	AF7	AF8	AF9	AF10	AF11	AF12	AF13	AF14	AF15
PI10	-	-	-	-	-	-	-	-	-	-	-	ETH_MII_RX _ER	DMC_CS	-	-	EVENTO UT
PI11	-	-	-	-	-	-	-	-	-	-	OTG_HS_ULPI _DIR	-	DMC_BA	-	-	EVENTO UT

4 Function Description

This chapter mainly introduces the system architecture, interrupt, on-chip memory, clock, power supply and peripheral features of APM32F405xG 407xExG series products; for information about the Arm® Cortex®-M4F core, please refer to the *Arm® Cortex®-M4F Technical Reference Manual*, which can be downloaded from Arm's website.

This version is applicable to APM32F405 and APM32F407 series A models.

4.1 System architecture

4.1.1 System block diagram

Figure 5 APM32F405xG 407xExG System Block Diagram

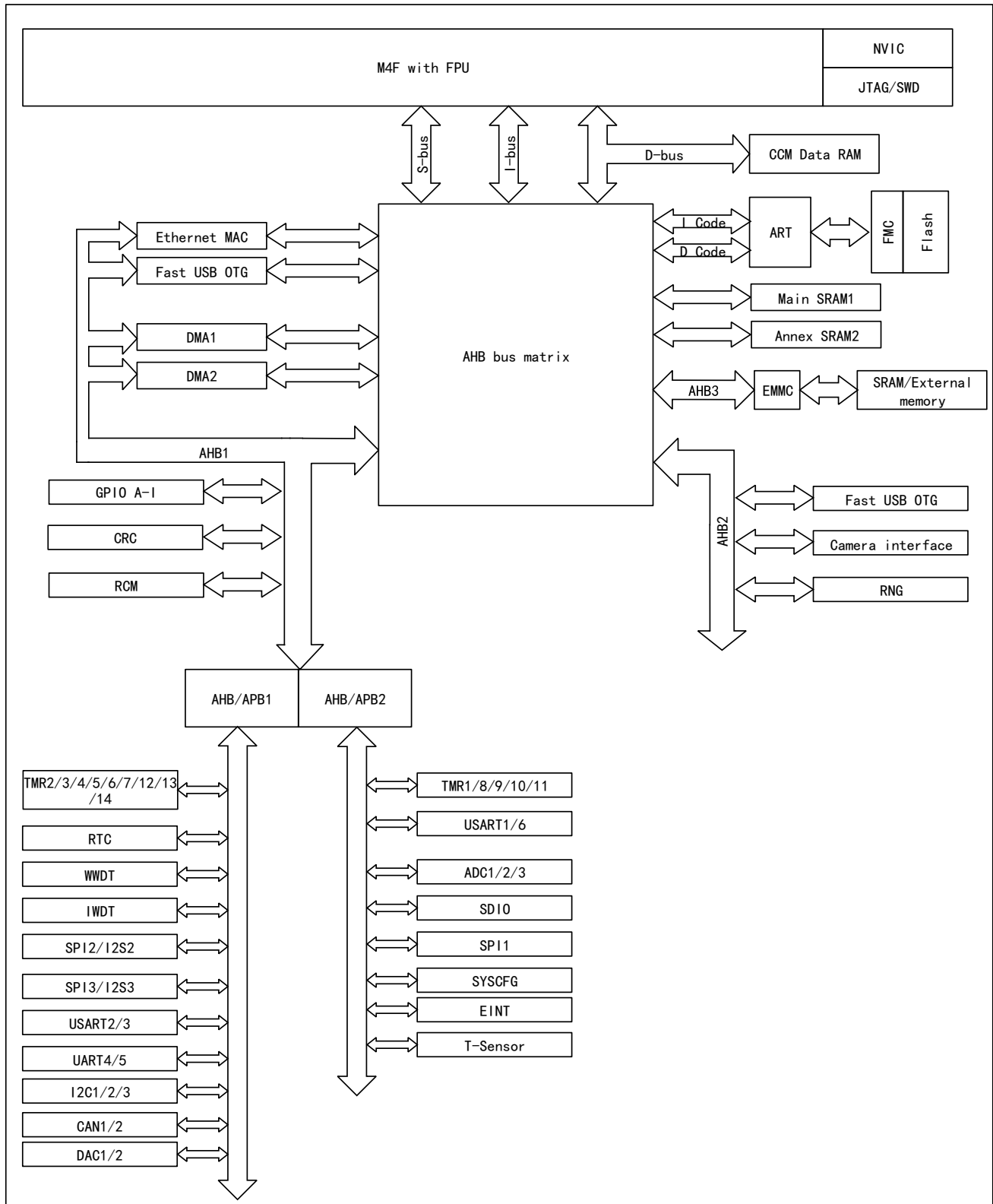

4.1.2 Address mapping

Table 13 APM32F405xG 407xExG Series Address Mapping

Region	Start Address	Peripheral Name
Code	0x0000 0000	Code mapping area
Code	0x0800 0000	FLASH
Code	0x0810 0000	Reserve
Code	0x1FFF 0000	System memory area
Code	0x1FFF 7800	OTP area
Code	0x1FFF 7A10	Reserve
Code	0x1FFF C000	Option byte
Code	0x1FFF C010	Reserve
SRAM	0x2000 0000	SRAM
—	0x2002 0000	Reserve
APB1 bus	0x4000 0000	TMR2
APB1 bus	0x4000 0400	TMR3
APB1 bus	0x4000 0800	TMR4
APB1 bus	0x4000 0C00	TMR5
APB1 bus	0x4000 1000	TMR6
APB1 bus	0x4000 1400	TMR7
APB1 bus	0x4000 1800	TMR12
APB1 bus	0x4000 1C00	TMR13
APB1 bus	0x4000 2000	TMR14
APB1 bus	0x4000 2400	Reserve
APB1 bus	0x4000 2800	RTC
APB1 bus	0x4000 2C00	WWDT
APB1 bus	0x4000 3000	IWDT
APB1 bus	0x4000 3400	I2S2ext
APB1 bus	0x4000 3800	SPI2/I2S2
APB1 bus	0x4000 3C00	SPI3/I2S3
APB1 bus	0x4000 4000	I2S3ext
APB1 bus	0x4000 4400	USART2
APB1 bus	0x4000 4800	USART3
APB1 bus	0x4000 4C00	UART4
APB1 bus	0x4000 5000	UART5
APB1 bus	0x4000 5400	I2C1
APB1 bus	0x4000 5800	I2C2
APB1 bus	0x4000 5C00	I2C3
APB1 bus	0x4000 6000	Reserve
APB1 bus	0x4000 6400	CAN1

Region	Start Address	Peripheral Name
APB1 bus	0x4000 6800	CAN2
APB1 bus	0x4000 6C00	Reserve
APB1 bus	0x4000 7000	PMU
APB1 bus	0x4000 7400	DAC
APB1 bus	0x4000 7800	Reserve
—	0x4000 8000	Reserve
APB2 bus	0x4001 0000	TMR1
APB2 bus	0x4001 0400	TMR8
APB2 bus	0x4001 0800	Reserve
APB2 bus	0x4001 1000	USART1
APB2 bus	0x4001 1400	USART6
APB2 bus	0x4001 1800	Reserve
APB2 bus	0x4001 2000	ADC1/2/3
APB2 bus	0x4001 2400	Reserve
APB2 bus	0x4001 2C00	SDIO
APB2 bus	0x4001 3000	SPI1
APB2 bus	0x4001 3400	Reserve
APB2 bus	0x4001 3800	SYSCFG
APB2 bus	0x4001 3C00	EINT
APB2 bus	0x4001 4000	TMR9
APB2 bus	0x4001 4400	TMR10
APB2 bus	0x4001 4800	TMR11
APB2 bus	0x4001 4C00	Reserve
—	0x4001 5800	Reserve
AHB bus	0x4002 0000	GPIOA
AHB bus	0x4002 0400	GPIOB
AHB bus	0x4002 0800	GPIOC
AHB bus	0x4002 0C00	GPIOD
AHB bus	0x4002 1000	GPIOE
AHB bus	0x4002 1400	GPIOF
AHB bus	0x4002 1800	GPIOG
AHB bus	0x4002 1C00	GPIOH
AHB bus	0x4002 2000	GPIOI
AHB bus	0x4002 2400	Reserve
AHB bus	0x4002 3000	CRC
AHB bus	0x4002 3400	Reserve
AHB bus	0x4002 3800	RCM
AHB bus	0x4002 3C00	FMC Reg.

Region	Start Address	Peripheral Name
AHB bus	0x4002 4000	Backups SRAM
AHB bus	0x4002 5000	Reserve
AHB bus	0x4002 6000	DMA1
AHB bus	0x4002 6400	DMA2
AHB bus	0x4002 6800	Reserve
AHB bus	0x4002 8000	MAC
AHB bus	0x4002 9400	Reserve
AHB bus	0x4004 0000	USB OTG_HS1/2
AHB bus	0x4008 0000	Reserve
AHB bus	0x5000 0000	USB OTG_FS
AHB bus	0x5004 0000	Reserve
AHB bus	0x5005 0000	DCI
AHB bus	0x5005 0400	Reserve
AHB bus	0x5006 0800	RNG
AHB bus	0x5006 0C00	Reserve
AHB bus	0xA000 0000	EMMC Reg.
—	0xA000 1000	Reserve
Core	0xE000 0000	Core peripheral
—	0xE010 0000	Reserve

4.1.3 Startup configuration

At startup, the user can select one of the following three startup modes by setting the high and low levels of the Boot pin:

- Startup from main memory
- Startup from BootLoader
- Startup from built-in SRAM

The user can use serial interface to reprogram the user Flash if starting up from BootLoader.

4.2 Core

The core of APM32F405xG 407xExG is Arm® Cortex®-M4F with FPU computing unit. Based on this platform, the development cost is low and the power consumption is low. It can provide excellent computing performance and advanced system interrupt response, and is compatible with all Arm tools and software.

4.3 Interrupt controller

4.3.1 Nested Vector Interrupt Controller (NVIC)

It embeds a nested vectored interrupt controller (NVIC) that can handle up to 82 maskable interrupt channels (not including 16 interrupt lines of Cortex®-M4F) and 8 priority levels. The

interrupt vector entry address can be directly transmitted to the core, so that the interrupt response processing with low delay can give priority to the late higher priority interrupt.

4.3.2 External Interrupt/Event Controller (EINT)

The external interrupt/event controller consists of 23 edge detectors, and each detector includes edge detection circuit and interrupt/event request generation circuit; each detector can be configured as rising edge trigger, falling edge trigger or both and can be masked independently. Up to 140 GPIOs can be connected to 16 external interrupt lines.

4.4 On-chip memory

On-chip memory includes main memory area, SRAM and information block; the information block includes system memory area and option byte; the system memory area stores BootLoader, 96-bit unique device ID and capacity information of main memory area; the system memory area has been written into the program when leaving the factory and cannot be erased.

Table 14 On-chip Memory Area

Memory	Maximum capacity	Function
Main memory area	1MB	Store user programs and data
SRAM	192 KB	CPU can access at 0 wait cycle (read/write)
System memory area	30KB	Store BootLoader, 96-bit unique device ID, and main memory area capacity information
Option byte	16Bytes	Configure main memory area read-write protection and MCU working mode

4.4.1 Configurable external memory controller (EMMC)

APM32F405xG 407xExG series integrates EMMC module, consists of SMC (static memory controller), DMC (dynamic memory controller), and supports PC card, SRAM, SDRAM, PSRAM, NorFlash and NandFlash.

Function introduction:

- Three EMMC interrupt sources, connected to NVIC unit through logic or
- Write FIFO
- The code can run in off-chip memories except NAND flash and PC card
- Connect to LCD

4.4.2 LCD parallel interface (LCD)

EMMC can be configured to seamlessly connect with most graphic LCD controllers, and supports the modes of Intel 8080 and Motorola 6800, and can flexibly connect with specific LCD interface. This LCD parallel interface can be used to easily build a simple graphics application environment or the high-performance scheme of the special acceleration controller can be used.

4.5 Clock

4.5.1 Clock tree

Clock tree of APM32F405xG 407xExG is shown in the figure below:

Figure 6 APM32F405xG 407xExG Clock Tree

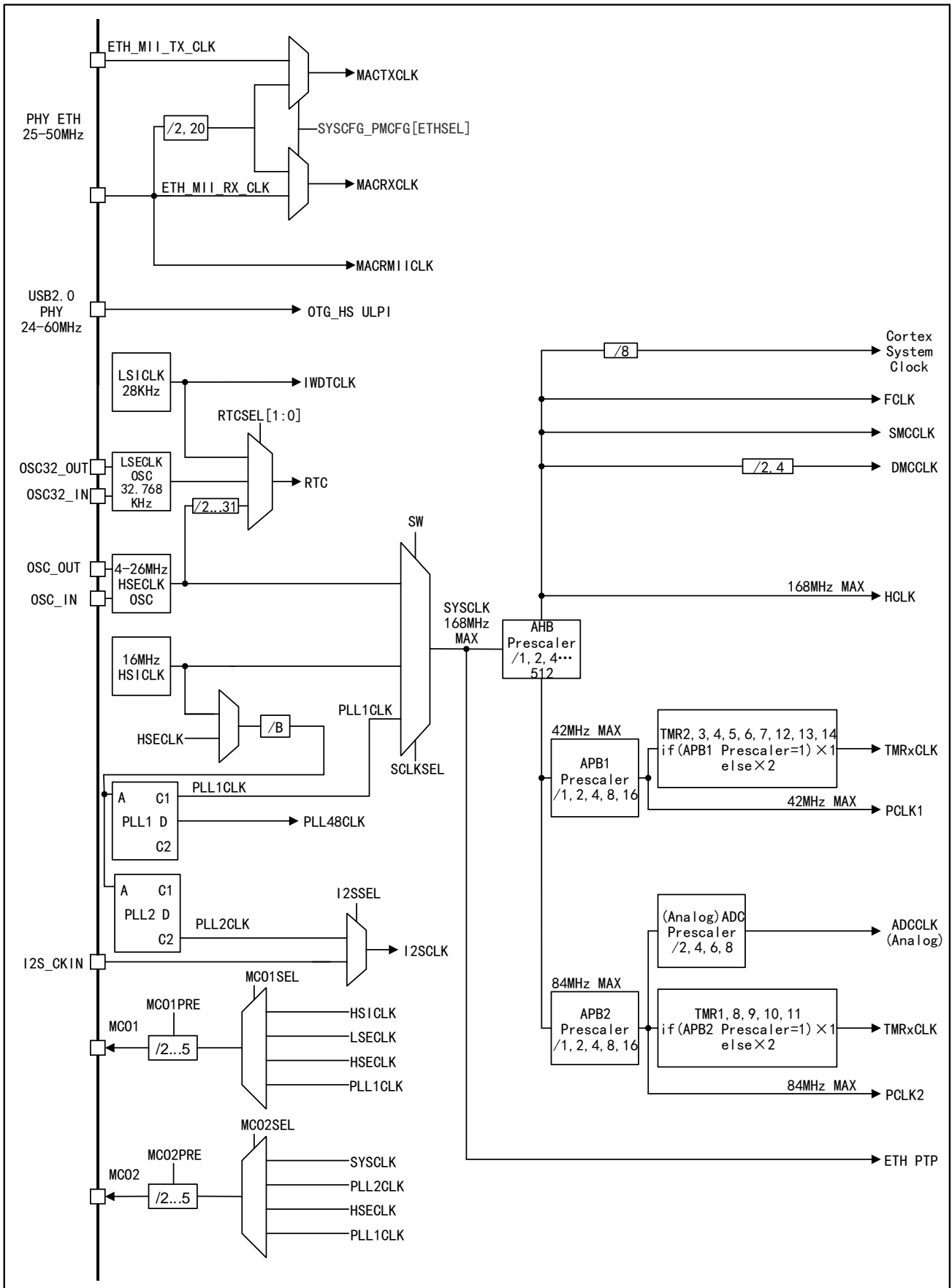

4.5.2 Clock source

Clock source is divided into high-speed clock and low-speed clock according to the speed; the high-speed clock includes HSICLK and HSECLK, and the low-speed clock includes LSECLK and LSICLK; besides, some modules may have additional clock source pins to obtain the required clock frequency through external circuits.

4.5.3 System clock

HSICLK, PLLCLK and HSECLK can be selected as system clock; the clock source of PLLCLK can be HSICLK or HSECLK; the required system clock can be obtained by configuring PLL clock multiplier factor and frequency division factor.

When the product is reset and started, HSICLK is selected as the system clock by default, and then the user can choose one of the above clock sources as the system clock. When HSECLK failure is detected, the system will automatically switch to the HSICLK, and if an interrupt is enabled, the software can receive the related interrupt.

4.5.4 Bus clock

AHB, APB1 and APB2 buses are built in. The clock source of AHB is SYSCLK, and the clock source of APB1 and APB2 is HCLK; the required clock can be obtained by configuring the frequency division factor. The maximum frequency of AHB is 168MHz, the maximum frequency of APB2 is 84MHz, and the maximum frequency of APB1 is 42MHz.

4.5.5 Phase locked loop

APM32F405xG 407xExG series product has two PLL, one is PLL (PLL1), and the other is PLL (PLL2) specially used to provide specific clock frequency for I2S. They all need to generate different clock frequencies by configuring parameters. Please refer to the *User Manual* for specific parameters and configuration registers.

4.6 Power and power management

4.6.1 Power supply scheme

Table 15 Power Supply Scheme

Name	Voltage range	Description
V _{DD}	1.8~3.6V	I/O (see pin distribution diagram for specific IO) and internal voltage regulator are powered through V _{DD} pin.
V _{DDA} /V _{SSA}	1.8~3.6V	Supply power for ADC, DAC, reset module, RC oscillator and PLL analog part; when ADC or DAC is used, V _{DDA} and V _{SSA} must be connected to V _{DD} and V _{SS} .
V _{BAT}	1.8~3.6V	When V _{DD} is disabled, RTC, external 32KHz oscillator and backup register are powered through internal power switch.

4.6.2 Voltage regulator

Table 16 Regulator Operating Mode

Name	Description
Master mode (MR)	Used in run mode
Low-power mode (LPR)	Used in stop mode
Power-down mode	Used in standby mode; when the voltage regulator has high-impedance output, the core circuit is powered down, the power consumption of the voltage regulator is zero, and all data of registers and SRAM will be lost.

Note: The voltage regulator is always in working state after reset, and outputs with high impedance in power-down mode.

4.6.3 Power supply voltage monitor

Power-on reset (POR), power-down reset (PDR) and brown-out reset circuits are integrated inside the product. These three circuits are always in working condition. When the power-down reset circuit monitors that the power supply voltage is lower than the specified threshold value ($V_{POR/PDR}$), even if the external reset circuit is used, the system will remain reset.

The product has a built-in programmable power supply voltage monitor (PVD) that can monitor V_{DD} and compare it with V_{PVD} threshold. When V_{DD} is outside the V_{PVD} threshold range and the interrupt is enabled, the MCU can be set to a safe state through the interrupt service program.

4.7 Low-power mode

APM32F405xG 407xExG supports three low-power modes, namely, sleep mode, stop mode and standby mode, and there are differences in power, wake-up time and wake-up mode among these three modes. The low-power mode can be selected according to the actual application requirements.

Table 17 Low-power Mode

Mode	Description
Sleep mode	The core stops working, all peripherals are working, and it can be woken up through interrupts/events
Stop mode	Under the condition that SRAM and register data are not lost, the lowest power consumption can be achieved in stop mode; The clock of the internal 1.3V power supply module will stop, HSECLK crystal resonator, HSICLK and PLL will be disabled, and the voltage regulator can be configured in normal mode or low-power mode; Any external interrupt line can wake up MCU, and the external interrupt lines include one of the 16 external interrupt lines, PVD output, RTC and USB_OTG.
Standby mode	The power consumption in this mode is the lowest; Internal voltage regulator is turned off, all 1.3V power supply modules are powered down, HSECLK crystal resonator, and HSICLK clocks are disabled, SRAM and register data disappear, RTC area and backup register contents remain, and the standby circuit still works;

Mode	Description
	The external reset signal on NRST, IWDT reset, rising edge on WKUP pin or RTC event will wake MCU out of standby mode.

4.8 DMA

2 built-in DMA, 16 data streams in total. Each data stream corresponds to 8 channels, but each data stream can only use 1 channel at the same time. The peripherals supporting DMA requests are ADC, SPI, USART, I2C, and TMRx. Four levels of DMA channel priority can be configured. Support "memory→memory, memory→peripheral, peripheral→memory" data transmission (the memory includes Flash、SRAM、SDRAM).

4.9 GPIO

GPIO can be configured as general input, general output, multiplexing function and analog input and output. The general input can be configured as floating input, pull-up input and pull-down input; the general output can be configured as push-pull output and open-drain output; the multiplexing function can be used for digital peripherals; and the analog input and output can be used for analog peripherals and low-power mode; the enable and disable pull-up/pull-down resistor can be configured; the speed of 2MHz, 10MHz, 50MHz and 100MHz can be configured; the higher the speed is, the greater the power and the noise will be.

4.10 Communication peripherals

4.10.1 USART/UART

Up to 6 universal synchronous/asynchronous transmitter receivers are built in the chip. The USART1/6 interfaces can communicate at a rate of 10.5Mbit/s, while other USART/UART interfaces can communicate at a rate of 5.25Mbit/s. All USART/UART interfaces can configure baud rate, parity check bit, stop bit, and data bit length; they all can support DMA.

USART/UART function differences are shown in the table below:

Table 18 USART/UART Function Differences

USART mode/function	USART1	USART2	USART3	UART4	UART5	USART6
Hardware flow control of modem	√	√	√	—	—	√
Smart card mode	√	√	√	—	—	√
IrDA SIR coder-encoder functions	√	√	√	√	√	√
LIN mode	√	√	√	√	√	√
Standard characteristics	√	√	√	√	√	√
SPI host	√	√	√	—	—	√
Maximum baud rate under 16-time oversampling (Mbit/s)	5.25	2.62	2.62	2.62	2.62	5.25

USART mode/function	USART1	USART2	USART3	UART4	UART5	USART6
Maximum baud rate under 8-time oversampling (Mbit/s)	10.50	5.25	5.25	5.25	5.25	10.5
APB mapping	APB2	APB1	APB1	APB1	APB1	APB2

Note: √ = support.

4.10.2 I2C

I2C1/2/3 bus interfaces are built-in and they all can work in multiple-master or slave modes, support 7-bit or 10-bit addressing, and support dual-slave addressing in 7-bit slave mode; the communication rate supports standard mode (up to 100kbit/s) and fast mode (up to 400kbit/s); hardware CRC generator/checker are built in; they can operate with DMA and support SMBus 2.0 version/PMBus.

4.10.3 SPI/I2S

3 built-in SPI, support full-duplex and half-duplex communication in master mode and slave mode, can use DMA controller, and can configure 4~16 bits per frame, and 3 SPI can communicate at a rate of up to 42Mbit/s, 21Mbit/s and 21Mbit/s respectively.

2 built-in I2S (multiplexed with SPI2 and SPI3 respectively), support half-duplex communication in master mode and slave mode, support synchronous transmission, and can be configured with 16-bit, 24-bit and 32-bit data transfer with 16-bit or 32-bit resolution. The configurable range of audio sampling rate is 8kHz~192kHz; when one or two I2S interfaces are configured as the master mode, the master clock can be output to external DAC or decoder (CODEC) at 256-time sampling frequency.

4.10.4 CAN

2 built-in CAN, compatible with 2.0A and 2.0B (active) specification, and can communicate at a rate of up to 1Mbit/s. It can receive and transmit standard frame of 11-bit identifier and extended frame of 29-bit identifier. It has 3 sending mailboxes and 2 receiving FIFO, and 14 3-level adjustable filters.

4.10.5 USB_OTG

Three USB controllers, namely, one OTG_FS and two OTG_HS, are embedded in the product. They all can support both host and slave functions to comply with the On-The-Go supplementary standard of USB 2.0 specification, and can also be configured as "Host only" or "Slave only" mode, to fully comply with USB 2.0 specification. OTG_FS clock (48MHz) is output by specific PLL, and OTG_HS clock (60MHz) is provided by external PHY.

4.10.6 Ethernet

Provides an IEEE-802.3-2002 compatible MAC for Ethernet LAN communication over MII or RMII. This MCU requires a PHY connection to a physical LAN bus. The PHY connects to the MII port, uses 17 signals for MII or 9 signals for RMII, and can use a 25MHz clock (MII) from the kernel.

4.10.7 SDIO

The secure digital input/output interface can connect SD card, SD I/O card, multi-media card (MMC) and CE-ATA card master interfaces, and provide data transmission between APB2 system bus and SD memory card, SD I/O card, MMC and CE-ATA device.

4.11 Analog peripherals

4.11.1 ADC

3 built-in ADC with 12-bit accuracy, up to 16 external channels and 3 internal channels for each ADC. The internal channels measure the temperature sensor voltage, reference voltage and backup voltage respectively. A/D conversion mode of each channel has single, continuous, scan or intermittent modes, ADC conversion results can be left aligned or right aligned and stored in 16-bit data register; they support analog watchdog, and DMA.

4.11.1.1 Temperature sensor

1 temperature sensor (TSensor) is built in, which is internally connected with ADC_IN16 channel. The voltage generated by the sensor changes linearly with temperature and the converted voltage value can be obtained by ADC and converted into temperature.

Table 19 Calibration Value of Tsensor Voltage

Calibration Value Name	Description	Memory Address
V _{sensor_CAL1}	Tsensor ADC raw data acquired at V _{DDA} =3.3V under 30°C	0x1FFF 7A2C - 0x1FFF 7A2S
V _{sensor_CAL2}	Tsensor ADC raw data acquired at V _{DDA} =3.3V under 110°C	0x1FFF 7A2E - 0x1FFF 7A2F

4.11.1.2 Internal reference voltage

Built-in reference voltage V_{REFINT}, internally connected to ADC_IN17 channel; V_{REFINT} can be obtained through ADC; V_{REFINT} provides stable voltage output for ADC.

Table 20 Calibration Value of Internal Reference Voltage

Calibration Value Name	Description	Memory Address
V _{REFINT_CAL}	Original data collected at V _{DDA} =3.3V(±10mV) under 25°C (±5°C)	0x1FFF 7A2A - 0x1FFF 7A2B

4.11.2 DAC

2 built-in 12-bit DAC, each corresponding to an output channel, which can be configured as 8-bit and 12-bit modes, and the DMA function is supported. The waveform generation supports noise wave and triangle wave. The conversion mode supports independent or simultaneous conversion and the trigger mode supports external signal trigger and internal timer update trigger.

4.12 Timer

2 built-in 16-bit advanced timers (TMR1/8), 8 16-bit general-purpose timers (TMR3/4/9/10/11/12/13/14), 2 32-bit general timers (TMR2/5), 2 16-bit basic timers (TMR6/7), 1 independent watchdog timer, 1 window watchdog timer and 1 system tick timer.

Watchdog timer can be used to detect whether the program is running normally.

The system tick timer is the peripheral of the core with automatic reloading function. When the counter is 0, it can generate a maskable system interrupt, which can be used for real-time operating system and general delay.

Table 21 Function Comparison between Advanced/General-purpose/Basic and System Tick Timers

Timer type	System tick timer	Basic timer	General-purpose timer			Advanced timer
Timer name	Sys Tick Timer	TMR6/7	TMR2/5	TMR3/4	TMR9/10 /11/12/13 /14	TMR1/8
Counter resolution	24 bits	16 bits	32 bits	16 bits	16 bits	16 bits
Counter type	Down	Up	Up, down, up/down		Up	Up, down, up/down
Prescaler factor	-	Any integer between 1 and 65536	Any integer between 1 and 65536			Any integer between 1 and 65536
Generate DMA request	-	OK	OK			OK
Capture/compare register	-	-	4			4
Complementary output	-	None	None			Yes
Pin characteristics	-	-	1-way external trigger signal input pin; 4-way non-complementary channel pin.			1-way external trigger signal input pin; 1-way braking input signal pin; 3-pair complementary channel pins; 1-way non-complementary channel pin.
Function Description	Special for real-time operating system.	Used to generate DAC trigger signals.	Synchronization or event chaining function provided.			It has complementary PWM output with

Timer type	System tick timer	Basic timer	General-purpose timer	Advanced timer
	Automatic reloading function supported. When the counter is 0, it can generate a maskable system interrupt. Can program the clock source.	Can be used as a 16-bit general-purpose timebase counter.	Timers in debug mode can be frozen. Can be used to generate PWM output. Each timer has independent DMA request mechanism. It can handle incremental encoder signals.	dead band insertion. When configured as a 16-bit standard timer, it has the same function as the TMRx timer. When configured as a 16-bit PWM generator, it has full modulation capability (0~100%). In debug mode, the timer can be frozen, and PWM output is disabled. Synchronization or event chaining function provided.

Table 22 Function Comparison between IWDT and WWDT

Name	Counter resolution	Counter type	Prescaler factor	Function description
Independent watchdog	12 bits	Down	Any integer between 1 and 256	The clock is provided by an internally independent RC oscillator of 28KHz, which is independent of the master clock, so it can run in stop and standby modes. The whole system can be reset in case of problems. It can provide timeout management for applications as a free-running timer. It can be configured as a software or hardware startup watchdog through option bytes. Timers in debug mode can be frozen.
Window watchdog	7 bits	Down	-	Can be set for free running. The whole system can be reset in case of problems. Driven by the master clock, it has early interrupt warning function; Timers in debug mode can be frozen.

4.13 RTC

1 RTC is built in, and there are LSECLK signal input pins (OS32_IN and OS32_OUT) and 2 TAMP input signal detection pins (RTC_TAMP1/2); the clock source can select external 32.768kHz crystal oscillator, resonator or oscillator, LSICLK and HSECLK/128; it is powered by V_{DD} by default; when V_{DD} is powered off, it can be automatically switched to V_{BAT} power supply, and RTC configuration and time data will not be lost; RTC configuration and time data will not be lost in case of system reset, software reset and power-on reset; it supports clock and calendar functions.

4.13.1 Backup domain

4KB backup SRAM and 20 backup registers are built in, and are powered by V_{DD} by default; when V_{DD} is powered off, it can be automatically switched to V_{BAT} power supply, and the data in backup register will not be lost; the data in backup register will not be lost in case of system reset, software reset and power-on reset.

4.14 RNG

A RNG is embedded, and it provides 32-bit random number generated by the integrated simulation.

4.15 DCI

DCI is used to receive high-speed data streams from CMOS camera. It supports different data formats and is applicable to black-and-white cameras, X24 cameras and so on.

4.16 CRC

1 CRC (cyclic redundancy check) computing unit is built in, which can generate CRC codes and operate 8-bit, 16-bit and 32-bit data.

5 Electrical Characteristics

5.1 Test conditions of electrical characteristics

5.1.1 Maximum and minimum values

Unless otherwise specified, all products are tested on the production line at $T_A=25^{\circ}\text{C}$. Its maximum and minimum values can support the worst environmental temperature, power supply voltage and clock frequency.

In the notes at the bottom of each table, it is stated that the data are obtained through comprehensive evaluation, design simulation or process characteristics and are not tested on the production line; on the basis of comprehensive evaluation, after passing the sample test,

take the average value and add and subtract three times the standard deviation (average $\pm 3\Sigma$) to get the maximum and minimum values.

5.1.2 Typical value

Unless otherwise specified, typical data are measured based on $T_A=25^{\circ}\text{C}$, $V_{DD}=V_{DDA}=3.3\text{V}$. These data are only used for design guidance.

5.1.3 Typical curve

Unless otherwise specified, typical curves will only be used for design guidance and will not be tested.

5.1.4 Power supply scheme

Figure 7 Power Supply Scheme

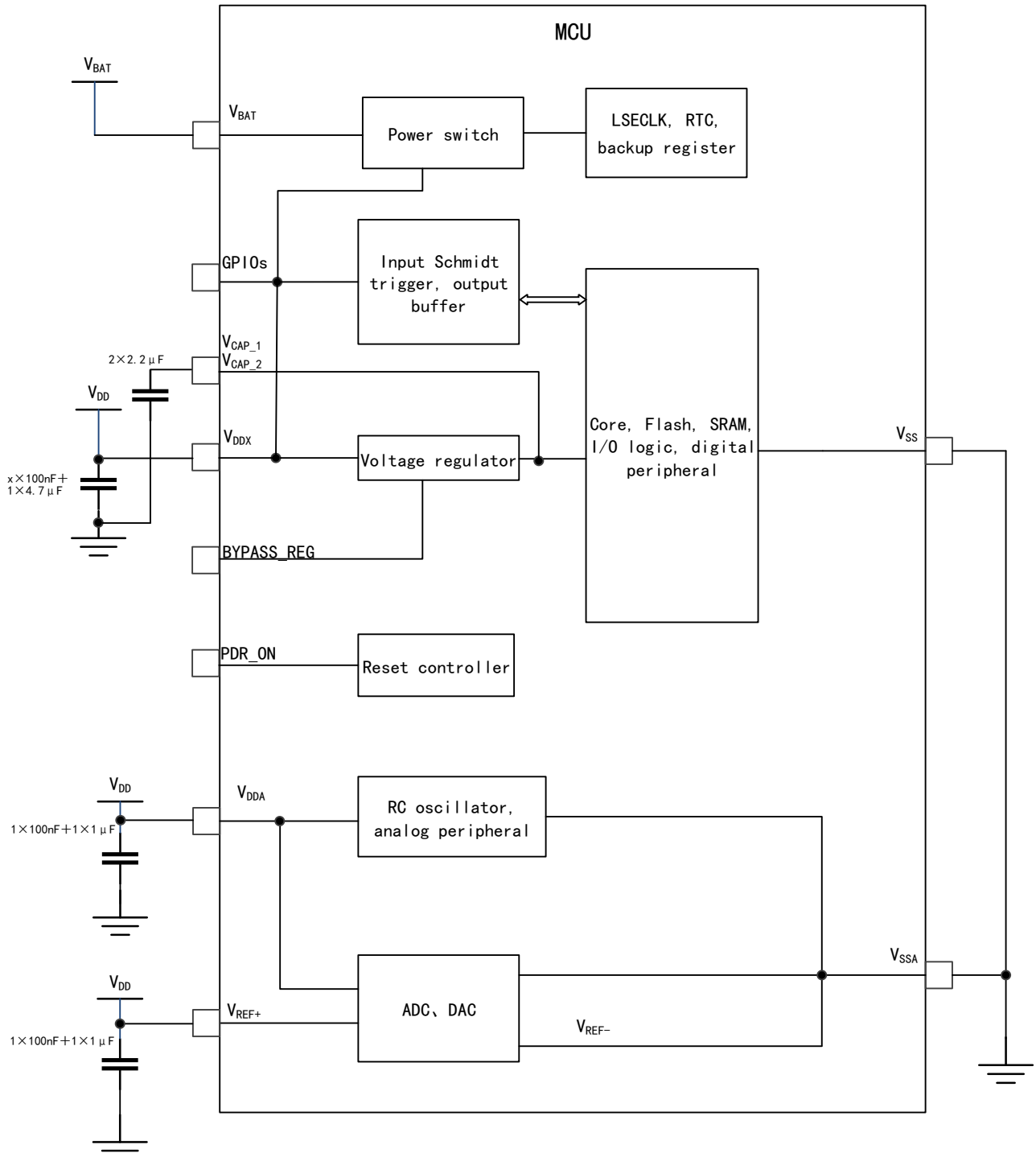

Notes: V_{DDx} in the figure means the number of V_{DD} is x

5.1.5 Load capacitance

Figure 8 Load conditions when measuring pin parameters

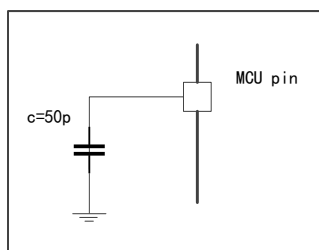

Figure 9 Pin Input Voltage Measurement Scheme

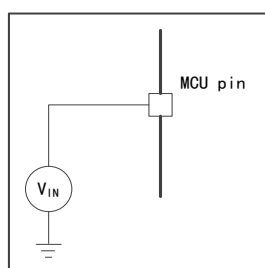
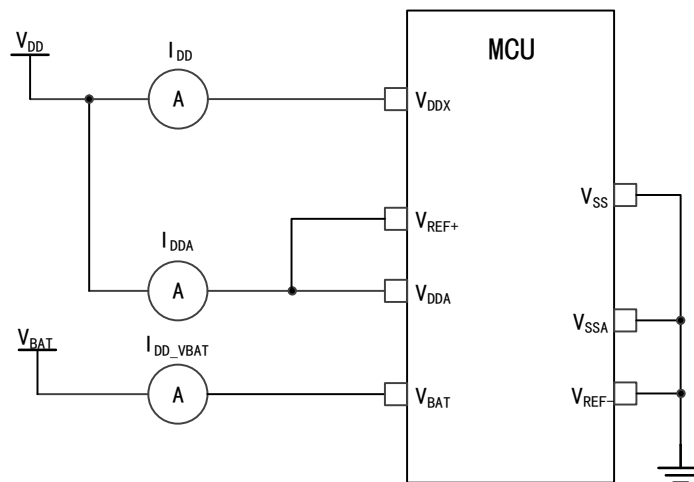

Figure 10 Power Consumption Measurement Scheme



5.2 Test under general operating conditions

Table 23 General Operating Conditions

Symbol	Parameter	Conditions	Minimum value	Maximum value	Unit
f_{HCLK}	Internal AHB clock frequency	-	-	168	MHz
f_{PCLK1}	Internal APB1 clock frequency	-	-	42	
f_{PCLK2}	Internal APB2 clock frequency	-	-	84	
V_{DD}	Main power supply voltage	-	1.8	3.6	V

Symbol	Parameter	Conditions	Minimum value	Maximum value	Unit
V_{DDA}	Analog power supply voltage (When neither ADC nor DAC is used)	Must be the same as V_{DD}	1.8	2.4	V
	Analog power supply voltage (When ADC and DAC are used)		2.4	3.6	
V_{BAT}	Power supply voltage of backup domain	-	1.65	3.60	V
T_A	Ambient temperature (temperature number 6)	Maximum power dissipation	-40	85	°C
	Ambient temperature (temperature number 7)		-40	105	°C

5.3 Absolute maximum ratings

If the load on the device exceeds the absolute maximum rating, it may cause permanent damage to the device. Here, only the maximum load that can be borne is given, and there is no guarantee that the device functions normally under this condition.

5.3.1 Maximum temperature characteristics

Table 24 Temperature Characteristics

Symbol	Description	Value	Unit
T_{STG}	Storage temperature range	-65 ~ +150	°C
T_J	Maximum junction temperature	125	°C

5.3.2 Maximum rated voltage characteristics

All power supply (V_{DD} , V_{DDA}) and ground (V_{SS} , V_{SSA}) pins must always be connected to the power supply within the external limited range.

Table 25 Maximum Rated Voltage Characteristics

Symbol	Description	Minimum value	Maximum value	Unit
$V_{DD} - V_{SS}$	External main power supply voltage	-0.3	4.0	V
V_{IN}	Input voltage on FT pins	$V_{SS}-0.3$	$V_{DD}+4$	
	Input voltage on other pins	$V_{SS}-0.3$	4.0	
$ \Delta V_{DDx} $	Voltage difference between different power supply pins	-	50	mV
$ V_{SSx}-V_{SS} $	Voltage difference between different grounding pins	-	50	

5.3.3 Maximum rated current characteristics

Table 26 Current Characteristics

Symbol	Description	Maximum value	Unit
I_{VDD}	Total current through V_{DD}/V_{DDA} power line (supply current) ⁽¹⁾	240	mA

Symbol	Description	Maximum value	Unit
I_{VSS}	Total current through V_{SS} ground line (outflow current) ⁽¹⁾	240	
I_{IO}	Sink current on any I/O and control pin	25	
	Source current on any I/O and control pin	25	
$I_{INJ(PIN)}^{(2)}$	Injection current of 5T pin	-5/+0	
	Injection current of other pins	±5	
$\Sigma I_{INJ(PIN)}^{(2)}$	Total injection current on all I/O and control pins ⁽⁴⁾	±25	

1. All power supply (V_{DD} , V_{DDA}) and ground (V_{SS} , V_{SSA}) must always be within the allowed range.
2. The outflow current will interfere with the analog performance of the device.
3. I/O cannot be injected positively: when $V_{IN} < V_{SS}$, $I_{INJ(PIN)}$ cannot exceed the maximum allowable input voltage value.
4. If V_{IN} exceeds the maximum value, $I_{INJ(PIN)}$ must be externally limited not to exceed the maximum value. When $V_{IN} > V_{DD}$, the current flows into the pins; when $V_{IN} < V_{SS}$, the current flows out of the pins.
5. When the current is injected into several I/O ports at the same time, the maximum value of $\Sigma I_{INJ(PIN)}$ is the sum of instantaneous absolute value of inflow current and outflow current.

5.3.4 Electro-static discharge (ESD)

Table 27 ESD Absolute Maximum Ratings

Symbol	Parameter	Conditions	Range	Unit
$V_{ESD(HBM)}$	Electrostatic discharge voltage (human body model)	$T_A = +25\text{ }^\circ\text{C}$, conforming to ANSI/ESDA/JEDEC JS-001-2017	±4000	V

Note: The samples are measured by a third-party testing organization and are not tested in production.

5.3.5 Static latch-up (LU)

Table 28 Static Latch-up

Symbol	Parameter	Conditions	Type
LU	Class of static latch-up	$T_A = +105\text{ }^\circ\text{C}$, conforming to JEDEC JESD78F-2022	Class II A

Note: The samples are measured by a third-party testing organization and are not tested in production.

5.4 On-chip memory

5.4.1 Flash characteristics

Table 29 Flash Memory Characteristics

Symbol	Parameter		Conditions	Minimum value	Typical value	Maximum value	Unit
t_{prog}	8/16/32-bit programming time		$T_A = -40\sim 105\text{ }^\circ\text{C}$ $V_{DD} = 2.4\sim 3.6\text{V}$	-	43	60	μs
t_{ERASE1}	Page (16KBytes) erase time	8 bits	$T_A = -40\sim 105\text{ }^\circ\text{C}$ $V_{DD} = 2.4\sim 3.6\text{V}$	-	60	120	ms
		16 bits		-	60	120	

Symbol	Parameter		Conditions	Minimum value	Typical value	Maximum value	Unit		
t _{ERASE2}	Page (64KBytes) erase time	32 bits	T _A = -40~105°C V _{DD} =2.4~3.6V	-	60	120	ms		
		8 bits		-	250	500			
		16 bits		-	250	500			
		32 bits		-	250	500			
t _{ERASE3}	Page (128KBytes) erase time	8 bits		-	500	1000			
		16 bits		-	500	1000			
		32 bits		-	500	1000			
t _{ME}	Mass erase time	8 bits		-	10	20			
		16 bits		-	10	20			
		32 bits		-	10	20			
V _{prog}	Voltage of 8-bit programming			T _A = -40~105°C	1.8	-		3.6	V
	Voltage of 16-bit programming				2.1	-		3.6	
	Voltage of 32-bit programming		2.7		-	3.6			

Note: The data are obtained from a comprehensive evaluation and are not tested in production.

5.5 Clock

5.5.1 Characteristics of external clock source

5.5.1.1 High-speed external clock generated by crystal resonator

For detailed parameters (frequency, package, precision, etc.) of crystal resonator, please consult the corresponding manufacturer.

Table 30 HSECLK4~26MHz Oscillator Characteristics

Symbol	Parameter	Conditions	Minimum value	Typical value	Maximum value	Unit
f _{OSC_IN}	Oscillator frequency	-	4	8	26	MHz
R _F	Feedback resistance	-	-	200	-	kΩ
I _{DD(HSECLK)}	HSECLK current consumption	V _{DD} =3.3V, C _L =10pF@8MHz	-	-	0.5	mA
t _{SU(HSECLK)}	Start-up Time	V _{DD} is stable	-	2	-	ms
G _m	Oscillator transconductance	Startup	5.65	-	-	mA/V

Note: The data are obtained from a comprehensive evaluation and are not tested in production.

5.5.1.2 Low-speed external clock generated by crystal resonator

For detailed parameters (frequency, package, precision, etc.) of crystal resonator, please consult the corresponding manufacturer.

Table 31 LSECLK Oscillator Characteristics ($f_{LSECLK} = 32.768\text{KHz}$)

Symbol	Parameter	Conditions	Minimum value	Typical value	Maximum value	Unit
f_{OSC_IN}	Oscillator frequency	-	-	32.768	-	KHz
$I_{DD(LSECLK)}$	LSECLK current consumption	-	-	-	1	μA
$t_{SU(LSECLK)}^{(1)}$	Start-up Time	V_{DD} is stable	-	2	-	s

Note: The data are obtained from a comprehensive evaluation and are not tested in production.

(1) $t_{SU(LSECLK)}$ is the startup time, which is measured from the time when LSECLK is enabled by software to the time when stable oscillation at 32.768KHz is obtained. This value is measured by using a standard crystal resonator, which may vary greatly due to different crystal manufacturers.

5.5.2 Characteristics of internal clock source

5.5.2.1 High-speed internal (HSICLK) RC oscillator

Table 32 HSICLK Oscillator Characteristics

Symbol	Parameter	Conditions	Minimum value	Typical value	Maximum value	Unit	
f_{HSICLK}	Frequency	-	-	16	-	MHz	
$Acc_{(HSICLK)}$	Accuracy of HSICLK oscillator	Factory calibration	$V_{DD}=3.3\text{V}, T_A=25^\circ\text{C}$	-1	-	1	%
			$V_{DD}=2-3.6\text{V}, T_A=-40\sim 105^\circ\text{C}$	-2	-	4	%
$I_{DDA(HSICLK)}$	Power consumption of HSICLK oscillator	-	-	100	120	μA	
$t_{SU(HSICLK)}$	Startup time of HSICLK oscillator	$V_{DD}=3.3\text{V}, T_A=-40\sim 105^\circ\text{C}$	-	3.7	5	μs	

Note: The data are obtained from a comprehensive evaluation and are not tested in production.

5.5.2.2 Low-speed internal (LSICLK) RC oscillator

Table 33 LSICLK Oscillator Characteristics

Symbol	Parameter	Minimum value	Typical value	Maximum value	Unit
f_{LSICLK}	Frequency ($V_{DD}=2-3.6\text{V}, T_A = -40\sim 105^\circ\text{C}$)	20	28	35	KHz
$I_{DD(LSICLK)}$	Power consumption of LSICLK oscillator	-	0.4	0.6	μA
$t_{SU(LSICLK)}$	Startup time of LSICLK oscillator, ($V_{DD}=3.3\text{V}, T_A=-40\sim 105^\circ\text{C}$)	-	16	40	μs

Note: The data are obtained from a comprehensive evaluation and are not tested in production.

5.5.3 PLL Characteristics

Table 34 PLL1 Characteristics

Symbol	Parameter	Value			Unit
		Minimum value	Typical value	Maximum value	
f _{PLL1_IN}	PLL1 input clock	0.92	1	2.1	MHz
	PLL1 input clock duty cycle	40	-	60	%
f _{PLL1_OUT}	PLL1 frequency multiplier output clock (V _{DD} =3.3V, T _A =-40~105°C)	24	-	168	MHz
f _{PLL1_48_OUT}	PLL1 frequency multiplier output 48MHz clock (V _{DD} =3.3V, T _A =-40~105°C)	-	48	75	MHz
t _{LOCK1}	PLL1 phase locking time	60	-	120	μs

Note: The data are obtained from a comprehensive evaluation and are not tested in production.

Table 35 PLL2 Characteristics

Symbol	Parameter	Value			Unit
		Minimum value	Typical value	Maximum value	
f _{PLL2_IN}	PLL2 input clock	0.92	1	2.1	MHz
	PLL2 input clock duty cycle	40	-	60	%
f _{PLL2_OUT}	PLL2 frequency multiplier output clock (V _{DD} =3.3V, T _A =-40~105°C)	20	-	144	MHz
t _{LOCK1}	PLL phase locking time	82	-	150	μs

5.6 Reset and power management

5.6.1 Test of Embedded Reset and Power Control Module Characteristics

Table 36 Embedded Reset and Power Control Module Characteristics

Symbol	Parameter	Conditions	Minimum value	Typical value	Maximum value	Unit
V _{POR/PDR}	Power-on/power-down reset threshold	Falling edge	1.68	1.70	1.70	V
		Rising edge	1.71	1.72	1.73	V
V _{BOR1}	Under-voltage threshold level 1	Falling edge	2.19	2.21	2.24	V
		Rising edge	2.27	2.29	2.30	V
V _{BOR2}	Under-voltage threshold level 2	Falling edge	2.49	2.51	2.55	V
		Rising edge	2.56	2.58	2.59	V
V _{BOR3}	Under-voltage threshold level 3	Falling edge	2.81	2.84	2.87	V
		Rising edge	2.89	2.91	2.92	V

Symbol	Parameter	Conditions	Minimum value	Typical value	Maximum value	Unit
V _{BORhyst}	BOR hysteresis	-	-	100	-	mV
V _{PDRhyst}	PDR hysteresis	-	-	40.00	50.00	mV
T _{RSTTEMPO}	Reset duration	-	0.70	0.95	1.48	ms

Note: The data are obtained from a comprehensive evaluation and are not tested in production.

Table 37 Programmable Power Supply Voltage Detector Characteristics

Symbol	Parameter	Conditions	Minimum value	Typical value	Maximum value	Unit
V _{PVD}	Programmable power supply voltage detector voltage level selection	PLS[2:0]=000 (rising edge)	2.14	-	2.18	V
		PLS[2:0]=000 (falling edge)	2.03	-	2.10	V
		PLS[2:0]=000 (PVD hysteresis)	80.00	-	120.00	mV
		PLS[2:0]=001 (rising edge)	2.30	-	2.34	V
		PLS[2:0]=001 (falling edge)	2.18	-	2.23	V
		PLS[2:0]=001 (PVD hysteresis)	90.00	-	120.00	mV
		PLS[2:0]=010 (rising edge)	2.44	-	2.48	V
		PLS[2:0]=010 (falling edge)	2.32	-	2.37	V
		PLS[2:0]=010 (PVD hysteresis)	110.00	-	120.00	mV
		PLS[2:0]=011 (rising edge)	2.58	-	2.63	V
		PLS[2:0]=011 (falling edge)	2.49	-	2.53	V
		PLS[2:0]=011 (PVD hysteresis)	90.00	-	100.00	mV
		PLS[2:0]=100 (rising edge)	2.75	-	2.80	V
		PLS[2:0]=100 (falling edge)	2.64	-	2.68	V
		PLS[2:0]=100 (PVD hysteresis)	110.00	-	120.00	mV
		PLS[2:0]=101 (rising edge)	2.91	-	2.97	V
		PLS[2:0]=101 (falling edge)	2.81	-	2.86	V
		PLS[2:0]=101 (PVD hysteresis)	100.00	-	110.00	mV
		PLS[2:0]=110 (rising edge)	3.02	-	3.08	V
		PLS[2:0]=110 (falling edge)	2.90	-	2.96	V
PLS[2:0]=110 (PVD hysteresis)	110.00	-	120.00	m.V		
PLS[2:0]=111 (rising edge)	3.12	-	3.19	V		
PLS[2:0]=111 (falling edge)	3.00	-	3.07	V		
PLS[2:0]=111 (PVD hysteresis)	110.00	-	120.00	mV		

Note: The data are obtained from a comprehensive evaluation and are not tested in production.

5.7 Power consumption

5.7.1 Power consumption test environment

- (1) The values are measured by executing Dhrystone 2.1, with the Keil.V5 compilation environment and the L0 compilation optimization level.
- (2) All I/O pins are in analog input mode and are connected to a static level at V_{DD} or V_{SS} (no load)
- (3) Unless otherwise specified, all peripherals are disabled
- (4) The relationship between Flash wait cycle setting and f_{HCLK} :
 - 0~30MHz: 0 wait cycle
 - 30~60MHz: 1 wait cycle
 - 60~90MHz: 2 wait cycles
 - 90~120MHz: 3 wait cycles
 - 120~150MHz: 4 wait cycles
 - 150~168MHz: 5 wait cycles
- (5) When the peripherals are enabled: $f_{PCLK1}=f_{HCLK}/4$, $f_{PCLK2}=f_{HCLK}/2$

5.7.2 Power consumption in run mode

Table 38 Power Consumption in Run Mode when the Program is Executed in Flash (ART is turned on)

Parameter	Conditions	f _{HCLK}	Typical value ⁽¹⁾		Maximum value ⁽¹⁾	
			T _A =25°C, V _{DD} =3.3V		T _A =105°C, V _{DD} =3.6V	
			I _{DDA} (μA)	I _{DD} (mA)	I _{DDA} (μA)	I _{DD} (mA)
Power consumption in run mode	HSECLK bypass ⁽²⁾ , enabling all peripherals ⁽³⁾	168MHz	751.56	67.70	802.20	74.02
		144MHz	693.94	52.75	745.20	57.66
		120MHz	637.4	44.49	691.10	49.39
		90MHz	780.88	34.37	831.70	39.375
		60MHz	636.86	23.86	689.60	28.7
		30MHz	636.62	13.29	689.40	18.099
		25MHz	115.372	10.83	127.76	15.627
		16MHz	115.42	7.21	127.93	11.905
		8MHz	115.36	3.93	127.77	8.587
		4MHz	115.33	2.31	127.78	6.967
	2MHz	115.36	1.49	127.82	6.17	
	HSECLK bypass ⁽²⁾ , disabling all peripherals	168MHz	750.88	28.35	801.40	34.352
		144MHz	692.84	22.02	744.70	26.958
		120MHz	636.82	18.54	691.10	23.48
		90MHz	779.80	14.45	831.90	19.302
		60MHz	636.52	10.04	689.80	14.924
		30MHz	636.40	5.75	690.20	10.563
		25MHz	115.32	4.38	128.66	9.115
		16MHz	115.34	3.01	128.44	7.673
		8MHz	115.36	1.86	127.80	6.481
4MHz		115.35	1.27	127.84	5.93	
2MHz	115.36	0.99	127.86	5.65		

Note:

(1) The data are obtained from a comprehensive evaluation and are not tested in production.

(2) The external clock is 4MHz; when f_{HCLK}>25MHz, turn on PLL; otherwise, turn off PLL.

(3) When the analog peripherals such as ADC, DAC, HSECLK, LSECLK, HSICLK and LSICLK are turned on, extra power consideration needs to be considered.

Table 39 Power Consumption in Run Mode when the Program is Executed in Flash (ART is turned off)

Parameter	Conditions	f _{HCLK}	Typical value ⁽¹⁾		Maximum value ⁽¹⁾	
			T _A =25°C, V _{DD} =3.3V		T _A =105°C, V _{DD} =3.6V	
			I _{DDA} (μA)	I _{DD} (mA)	I _{DDA} (μA)	I _{DD} (mA)
Power consumption in run mode	HSECLK bypass ⁽²⁾ , enabling all peripherals ⁽³⁾	168MHz	751.66	64.25	802.00	70.52
		144MHz	693.58	51.09	745.30	56.05
		120MHz	637.26	43.99	690.20	48.92
		90MHz	780.86	34.91	831.40	39.97
		60MHz	636.78	25.02	689.40	29.90
		30MHz	636.66	14.33	689.00	19.32
		25MHz	115.36	11.80	127.72	16.725
		16MHz	115.36	7.83	127.75	12.53
		8MHz	115.35	4.27	127.80	8.99
		4MHz	115.35	2.45	127.88	7.13
	2MHz	115.362	1.57	127.76	6.28	
	HSECLK bypass ⁽²⁾ , disabling all peripherals	168MHz	750.94	24.71	801.40	30.85
		144MHz	692.82	20.21	744.70	25.18
		120MHz	636.76	17.96	689.80	22.91
		90MHz	780.46	15.03	831.60	20.01
		60MHz	636.46	11.19	689.80	16.13
		30MHz	636.38	6.79	689.90	11.68
		25MHz	115.33	5.26	128.50	10.15
		16MHz	115.32	3.65	127.96	8.46
		8MHz	115.36	2.14	127.82	6.80
4MHz		115.35	1.43	127.68	6.11	
2MHz	115.53	1.07	127.90	5.82		

Note:

(1) The data are obtained from a comprehensive evaluation and are not tested in production.

(2) The external clock is 4MHz; when f_{HCLK}>25MHz, turn on PLL; otherwise, turn off PLL.

(3) When the analog peripherals such as ADC, DAC, HSECLK, LSECLK, HSICLK and LSICLK are turned on, extra power consideration needs to be considered.

Table 40 Power Consumption in Run Mode when the Program is Executed in RAM

Parameter	Conditions	f _{HCLK}	Typical value ⁽¹⁾		Maximum value ⁽¹⁾	
			T _A =25°C, V _{DD} =3.3V		T _A =105°C, V _{DD} =3.6V	
			I _{DDA} (μA)	I _{DD} (mA)	I _{DDA} (μA)	I _{DD} (mA)
Power consumption in run mode	HSECLK bypass ⁽²⁾ , enabling all peripherals ⁽³⁾	168MHz	752.14	70.29	803.80	76.51
		144MHz	693.74	54.73	745.50	59.73
		120MHz	637.60	46.22	690.40	51.16
		90MHz	781.00	35.67	832.00	40.53
		60MHz	637.02	24.70	689.8	29.65
		30MHz	636.74	13.74	689.2	18.596
		25MHz	115.42	11.23	127.85	16.02
		16MHz	115.374	7.42	127.88	12.21
		8MHz	115.37	4.05	127.81	8.836
		4MHz	115.376	2.38	127.72	7.12
	2MHz	115.347	1.53	127.76	6.28	
	HSECLK bypass ⁽²⁾ , disabling all peripherals	168MHz	751.38	31.03	802.4	37.29
		144MHz	693.00	24.11	744.7	29.11
		120MHz	636.88	20.30	689.80	25.23
		90MHz	780.56	15.81	931.60	20.74
		60MHz	636.68	10.92	690.00	15.80
		30MHz	636.62	6.19	689.70	11.02
		25MHz	115.36	4.75	128.42	9.48
		16MHz	115.35	3.26	128.79	8.07
		8MHz	115.38	1.97	127.76	6.71
4MHz		115.36	1.33	127.73	6.04	
2MHz	115.34	1.02	127.74	5.70		

Note:

(1) The data are obtained from a comprehensive evaluation and are not tested in production.

(2) The external clock is 4MHz, and when f_{HCLK}>25MHz, turn on PLL, otherwise, turn off PLL.

(3) When the analog peripherals such as ADC, DAC, HSECLK, LSECLK, HSICLK and LSICLK are turned on, extra power consideration needs to be considered.

5.7.3 Power consumption in sleep mode

Table 41 Power Consumption in Sleep Mode when the Program is Executed in Flash (ART is turned off)

Parameter	Conditions	f _{HCLK}	Typical value ⁽¹⁾		Maximum value ⁽¹⁾	
			T _A =25°C, V _{DD} =3.3V		T _A =105°C, V _{DD} =3.6V	
			I _{DDA} (μA)	I _{DD} (mA)	I _{DDA} (μA)	I _{DD} (mA)
Power consumption in sleep mode	HSECLK bypass ⁽²⁾ , enabling all peripherals	168MHz	751.34	54.18	802.1	60.33
		144MHz	693.26	42.25	745.00	47.12
		120MHz	637.24	35.75	689.80	40.53
		90MHz	780.60	27.69	831.20	32.539
		60MHz	636.72	19.33	689.20	24.149
		30MHz	636.46	11.02	689.20	15.8
		25MHz	115.356	8.96	127.77	13.7
		16MHz	115.34	5.99	127.71	10.68
		8MHz	115.334	3.33	127.78	8.01
		4MHz	115.332	2.00	127.84	6.669
	2MHz	115.352	1.34	127.82	6.017	
	HSECLK bypass ⁽²⁾ , disabling all peripherals	168MHz	750.52	13.91	801.00	19.86
		144MHz	692.58	10.82	743.90	15.64
		120MHz	636.46	9.20	689.00	13.99
		90MHz	780.24	7.44	830.60	12.21
		60MHz	636.42	5.33	689.00	10.07
		30MHz	636.36	3.38	688.80	8.10
		25MHz	115.37	2.41	127.84	7.08
		16MHz	115.35	1.79	127.74	6.46
		8MHz	115.35	1.23	127.83	5.91
4MHz		115.36	0.96	127.86	5.63	
2MHz	115.42	0.83	127.84	5.54		

Note:

(1) The data are obtained from a comprehensive evaluation and are not tested in production.

(2) The external clock is 4MHz; when f_{HCLK}>25MHz, turn on PLL; otherwise, turn off PLL.

5.7.4 Power consumption in stop mode

Table 42 Power Consumption in Stop Mode

Conditions		Typical value ⁽¹⁾ , (T _A =25°C)						Maximum value ⁽¹⁾ , (V _{DD} =3.6V)	
		V _{DD} =2.4V		V _{DD} =3.3V		V _{DD} =3.6V		T _A =105°C	
		I _{DDA} (μA)	I _{DD} (mA)	I _{DDA} (μA)	I _{DD} (mA)	I _{DDA} (μA)	I _{DD} (mA)	I _{DDA} (μA)	I _{DD} (mA)
The regulator is in run mode, and all oscillators are in off state	Flash is in stop mode, and RC internal oscillator and high-speed oscillator are turned off (with no independent watchdog)	9.28	0.69	9.80	0.70	10.05	0.71	12.36	20.00
	Flash is in power-down mode, and RC internal oscillator and high-speed oscillator are turned off (with no independent watchdog)	9.23	0.69	9.72	0.70	10.00	0.70	12.35	20.00
The regulator is in low-power mode, and all oscillators are in off state	Flash is in stop mode, and RC internal oscillator and high-speed oscillator are turned off (with no independent watchdog)	4.18	0.21	4.65	0.21	4.87	0.21	5.91	15.00
	Flash is in power-down mode, and RC internal oscillator and high-speed oscillator are turned off (with no independent watchdog)	4.19	0.20	4.64	0.20	4.86	0.20	5.86	15.00

Note: It is tested in comprehensive evaluation instead of in production.

5.7.5 Power consumption in standby mode

Table 43 Power Consumption in Standby Mode

Conditions		Typical value ⁽¹⁾ , (T _A =25°C)						Maximum value ⁽¹⁾ , (V _{DD} =3.6V)	
		V _{DD} =2.4V		V _{DD} =3.3V		V _{DD} =3.6V		T _A =105°C	
		I _{DDA} (μA)	I _{DD} (μA)	I _{DDA} (μA)	I _{DD} (μA)	I _{DDA} (μA)	I _{DD} (μA)	I _{DDA} (μA)	I _{DD} (μA)
Power supply current in standby mode	The backup SRAM is turned on, and the low-speed oscillator and RTC are turned on	2.15	8.38	2.56	9.73	2.83	10.19	3.76	59.39
	The backup SRAM is turned off, and the low-speed oscillator and RTC are turned on	2.15	3.52	2.62	4.46	2.81	5.11	3.48	32.00

Conditions	Typical value ⁽¹⁾ , (T _A =25°C)						Maximum value ⁽¹⁾ , (V _{DD} =3.6V)	
	V _{DD} =2.4V		V _{DD} =3.3V		V _{DD} =3.6V		T _A =105°C	
	I _{DDA} (μA)	I _{DD} (μA)	I _{DDA} (μA)	I _{DD} (μA)	I _{DDA} (μA)	I _{DD} (μA)	I _{DDA} (μA)	I _{DD} (μA)
The backup SRAM is turned on, and the RTC is turned off	2.13	7.33	2.62	8.24	2.81	8.64	3.45	58.24
The backup SRAM is turned off, and the RTC is turned off	2.13	2.51	2.61	3.31	2.78	3.68	3.45	19.2

Note: (1) The data are obtained from a comprehensive evaluation and are not tested in production.

5.7.6 Peripheral power consumption

Peripheral power consumption = current that enables the peripheral clock-current that disables the peripheral clock.

Table 44 Peripheral Power Consumption

Parameter	Peripheral	Typical value ⁽¹⁾ T _A =25°C, V _{DD} =3.3V		Unit
		168MHz	144MHz	
AHB1 (up to 168MHz)	DMA1	5.4	4.21	μA/MHz
	DMA2	5.56	4.3	
	ETH	3	2.35	
	OTG_HS	4.21	3.26	
	GPIOA	0.32	0.25	
	GPIOB	0.31	0.24	
	GPIOC	0.32	0.24	
	GPIOD	0.3	0.23	
	GPIOE	0.31	0.25	
	GPIOF	0.33	0.26	
	GPIOG	0.3	0.24	
	GPIOH	0.3	0.24	
	GPIOI	0.3	0.24	
CRC	0.03	0.03		
AHB2 (up to 168MHz)	OTG_FS	3.12	2.41	
	DCI	0.79	0.61	
	RNG	0.16	0.12	
	HASH	1.3	1	
	CRYP	0.25	0.19	

Parameter	Peripheral	Typical value ⁽¹⁾ T _A =25°C, V _{DD} =3.3V		Unit
		168MHz	144MHz	
AHB3 (up to 168MHz)	EMMC	1.68	1.3	
APB1 (up to 42MHz)	TMR2	0.46	0.36	
	TMR3	0.35	0.27	
	TMR4	0.34	0.27	
	TMR5	0.46	0.35	
	TMR6	0.08	0.07	
	TMR7	0.08	0.06	
	TMR12	0.19	0.15	
	TMR13	0.14	0.11	
	TMR14	0.14	0.1	
	WWDT	0.02	0.02	
	SPI2/I2S2	0.12	0.1	
	SPI3/I2S3	0.12	0.1	
	USART2	0.11	0.09	
	USART3	0.12	0.09	
	UART4	0.11	0.08	
	UART5	0.11	0.08	
	I2C1	0.12	0.09	
	I2C2	0.12	0.09	
	I2C3	0.12	0.1	
	CAN1	0.18	0.14	
CAN2	0.16	0.13		
PMU	0.01	0.01		
DAC	0.08	0.06		
APB2 (up to 84MHz)	SDIO	0.41	0.32	
	TMR1	0.99	0.77	
	TMR8	0.97	0.77	
	TMR9	0.41	0.32	
	TMR10	0.27	0.21	
	TMR11	0.26	0.22	
	ADC1	0.27	0.22	
	ADC2	0.27	0.22	

Parameter	Peripheral	Typical value ⁽¹⁾ T _A =25°C, V _{DD} =3.3V		Unit
		168MHz	144MHz	
	ADC3	0.28	0.23	
	SPI1	0.12	0.11	
	USART1	0.22	0.18	
	USART6	0.21	0.18	
	SYSCFG	0.05	0.05	

Note: The data are obtained from a comprehensive evaluation and are not tested in production.

5.7.7 Backup Domain Power Consumption

Table 45 V_{BAT} Power Consumption

Symbol	Parameter	Conditions	Typical value ⁽¹⁾ , T _A =25°C		Maximum value ⁽¹⁾ , V _{BAT} =3.6V		Unit
			V _{BAT} =2.4V	V _{BAT} =3.3V	T _A =85°C	T _A =105°C	
I _{DD_VBAT}	LSECLK and RTC are in ON state	The backup SRAM is turned on, and the low-speed oscillator and RTC are turned on	1.894	2.262	6	11	μA
		The backup SRAM is turned off, and the low-speed oscillator and RTC are turned on	1.08	1.412	3	5	
		The backup SRAM is turned on, and the RTC is turned off	0.926	1.116	5	10	
		The backup SRAM is turned off, and the RTC is turned off	0.02	0.128	2	4	

Note: (1) The data are obtained from a comprehensive evaluation and are not tested in production.

5.8 Wake-up time in low-power mode

The measurement of wake-up time in low-power mode is from the start of wake-up event to the time when the user program reads the first instruction, in which V_{DD}=V_{DDA}.

Table 46 Wake-up Time in Low-power Mode

Symbol	Parameter	Conditions	Min	Typ	Max	Unit
t _{WUSLEEP}	Wake-up from sleep mode	-	39.00	59	61.20	ns
t _{WUSTOP}	Wake up from the stop mode	The regulator is in run mode, and Flash is in stop state	12.51	13.602	14.99	μs

Symbol	Parameter	Conditions	Min	Typ	Max	Unit
		The regulator is in low-power mode, and Flash is in stop state	15.51	19.552	22.93	
		The regulator is in run mode, and Flash is in deep power-down mode	125.63	133.156	135.16	
		The regulator is in low-power mode, and Flash is in deep power-down mode	133.52	136.956	139.60	
twUSTDBY	Wake up from standby mode	-	173.03	214.056	227.96	

Note: The data are obtained from a comprehensive evaluation and are not tested in production.

5.9 I/O port characteristics

Table 47 DC Characteristics ($T_A = -40^{\circ}\text{C} \sim 105^{\circ}\text{C}$, $V_{DD} = 2 \sim 3.6\text{V}$)

Symbol	Parameter	Conditions	Min	Typ	Max	Unit
V_{IL}	Low-level input voltage	STD and STDA I/O	-	-	$0.3V_{DD} - 0.04$	V
		5T and 5Tf I/O	-	-	$0.3V_{DD}$	
		Boot0 pin	-	-	$0.1V_{DD} + 0.1$	
V_{IH}	High-level input voltage	STD and STDA I/O	$0.45V_{DD} + 0.3$	-	-	V
		5T and 5Tf I/O	$0.7V_{DD}$	-	-	
		Boot0 pin	$0.17V_{DD} + 0.7$	-	-	
V_{hys}	Schmidt trigger hysteresis	STD, STDA and 5T, 5Tf I/O	$10\% V_{DD}$	-	-	mV
		Boot0 pin	0.1	-	-	
I_{lkg}	Input leakage current	STDA in digital mode, $V_{DDIOx} \leq V_{IN} \leq V_{DDA}$	-	-	± 1	μA
		5T and 5Tf I/O, $V_{DDIOx} \leq V_{IN} \leq 5\text{V}$	-	-	3	
R_{PU}	Weak pull-up equivalent resistance	Except PA10 and PB12, $V_{IN} = V_{SS}$	30	40	50	k Ω
		PA10 and PB12	7	10	14	
R_{PD}	Weak pull-down equivalent resistance	Except PA10 and PB12, $V_{IN} = V_{DD}$	30	40	50	
		PA10 and PB12	7	10	14	
C_{IO}	I/O pin capacitance	-	-	5	-	pF

Table 48 AC Characteristics ($T_A = 25^{\circ}\text{C}$)

SPEED[1:0]	Symbol	Parameter	Conditions	Min	Max	Unit
00	$f_{\max(\text{IO})\text{out}}$	Maximum frequency	$CL = 50\text{pF}, V_{DD} > 2.7\text{V}$	-	4	MHz
			$CL = 50\text{pF}, V_{DD} > 1.8\text{V}$	-	2	

SPEED[1:0]	Symbol	Parameter	Conditions	Min	Max	Unit
			CL=10pF, V _{DD} >2.7V	-	8	
			CL=10pF, V _{DD} >1.8V	-	4	
	t _{r(IO)out} /t _{r(IO)out}	Fall time of output from high to low level and rise time of output from low to high level	C _L =50 pF, V _{DD} =1.8 V-3.6V	-	100	ns
01	f _{max(IO)out}	Maximum frequency	CL=50pF, V _{DD} >2.7V	-	25	MHz
			CL=50pF, V _{DD} >1.8V	-	12.5	
			CL=10pF, V _{DD} >2.7V	-	50	
			CL=10pF, V _{DD} >1.8V	-	20	
	t _{r(IO)out} /t _{r(IO)out}	Fall time of output from high to low level and rise time of output from low to high level	CL=30pF, V _{DD} >2.7V	-	10	ns
			CL=30pF, V _{DD} >1.8V	-	20	
			CL=10pF, V _{DD} >2.7V	-	6	
			CL=10pF, V _{DD} >1.8V	-	10	
10	f _{max(IO)out}	Maximum frequency	CL=30pF, V _{DD} >2.7V	-	50	MHz
			CL=30pF, V _{DD} >1.8V	-	25	
			CL=10pF, V _{DD} >2.7V	-	100	
			CL=10pF, V _{DD} >1.8V	-	50	
	t _{r(IO)out} /t _{r(IO)out}	Fall time of output from high to low level and rise time of output from low to high level	CL=30pF, V _{DD} >2.7V	-	6	ns
			CL=30pF, V _{DD} >1.8V	-	10	
			CL=10pF, V _{DD} >2.7V	-	4	
			CL=10pF, V _{DD} >1.8V	-	6	
11	f _{max(IO)out}	Maximum frequency	CL=30pF, V _{DD} >2.7V	-	100	MHz
			CL=30pF, V _{DD} >1.8V	-	50	
			CL=10pF, V _{DD} >2.7V	-	180	
			CL=10pF, V _{DD} >1.8V	-	100	
	t _{r(IO)out} /t _{r(IO)out}	Fall time of output from high to low level and rise time of output from low to high level	CL=30pF, V _{DD} >2.7V	-	4	ns
			CL=30pF, V _{DD} >1.8V	-	6	
			CL=10pF, V _{DD} >2.7V	-	2.5	
			CL=10pF, V _{DD} >1.8V	-	4	
-	t _{EINT} pw	Pulse width of external signal detected by EINT controller	-	10	-	

Figure 11 I/O AC Characteristics Definition

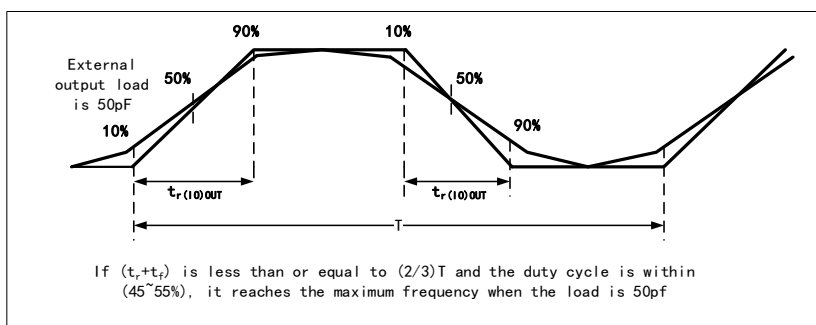

Table 49 Output Drive Voltage Characteristics (T_A=25°C)

Symbol	Parameter	Conditions	Min	Max	Unit
V _{OL}	I/O pin outputs low voltage	CMOS port, I _{IO} =8mA, 2.7 V < V _{DD} < 3.6 V	-	0.4	V
V _{OH}	I/O pin outputs high voltage		V _{DD} -0.4	-	
V _{OL}	I/O pin outputs low voltage	TTL port, I _{IO} =20mA, 2.7 V < V _{DD} < 3.6 V	-	0.4	V
V _{OH}	I/O pin outputs high voltage		2.4	-	
V _{OL}	I/O pin outputs low voltage	I _{IO} =20mA, 2.7 V < V _{DD} < 3.6 V	-	1.3	V
V _{OH}	I/O pin outputs high voltage		V _{DD} -1.3	-	
V _{OL}	I/O pin outputs low voltage	I _{IO} =6mA, 2.7 V < V _{DD} < 3.6 V	-	0.4	V
V _{OH}	I/O pin outputs high voltage		V _{DD} -0.4	-	

Note: The data are obtained from a comprehensive evaluation and are not tested in production.

5.10 NRST pin characteristics

The NRST pin input drive adopts CMOS process, which is connected with a permanent pull-up resistor RPU.

Table 50 NRST Pin Characteristics (T_A=-40~105°C, V_{DD}=2~3.6V)

Symbol	Parameter	Conditions	Min	Typ	Max	Unit
V _{IL(NRST)}	NRST low-level input voltage	TTL port, 2.7V≤V _{DD} ≤3.6V	-	-	0.8	V
V _{IH(NRST)}	NRST high-level input voltage		2	-	-	
V _{IL(NRST)}	NRST low-level input voltage	CMOS port, 1.8V≤V _{DD} ≤3.6V	-	-	0.3V _{DD}	V
V _{IH(NRST)}	NRST high-level input voltage		0.7V _{DD}	-	-	
V _{hys(NRST)}	NRST Schmidt trigger voltage hysteresis	-	-	200	-	mV
R _{PU}	Weak pull-up equivalent resistance	V _{IN} =V _{SS}	30	40	50	kΩ
V _{F(NRST)}	NRST input filter pulse	-	-	-	100	ns
V _{NF(NRST)}	NRST input unfiltered pulse	V _{DD} >2.7V	300	-	-	
T _{NRST_OUT}	Generated reset pulse duration	Reset internal source	20	-	-	μs

5.11 Communication peripherals

5.11.1 I2C peripheral characteristics

To achieve maximum frequency of I2C in standard mode, f_{PCLK1} must be greater than 2MHz. To achieve maximum frequency of I2C in fast mode, f_{PCLK1} must be greater than 4MHz.

Table 51 I2C Interface Characteristics ($T_A=25^\circ\text{C}$, $V_{DD}=3.3\text{V}$)

Symbol	Parameter	Standard I2C		Fast I2C		Unit
		Min	Max	Min	Max	
$t_{w(SCLL)}$	SCL clock low time	4.7	-	1.3	-	μs
$t_{w(SCLH)}$	SCL clock high time	4.0	-	0.6	-	
$t_{su(SDA)}$	SDA setup time	250	-	100	-	ns
$t_h(SDA)$	SDA data hold time	0	-	0	900	
$t_r(SDA)/t_r(SCL)$	SDA and SCL rise time	-	1000	$20+0.1C_b$	300	
$t_f(SDA)/t_f(SCL)$	SDA and SCL fall time	-	300	-	300	
$t_h(STA)$	Start condition hold time	4.0	-	0.6	-	μs
$t_{su(STA)}$	Setup time of repeated start condition	4.7	-	0.6	-	
$t_{su(STO)}$	Setup time of stop condition	4.0	-	0.6	-	
$t_w(STO:STA)$	Time from stop condition to start condition (the bus is idle)	4.7	-	1.3	-	
C_b	Capacitive load of each bus	-	400	-	400	pF

Note: The data are obtained from a comprehensive evaluation and are not tested in production.

Figure 12 Bus AC Waveform and Measurement Circuit

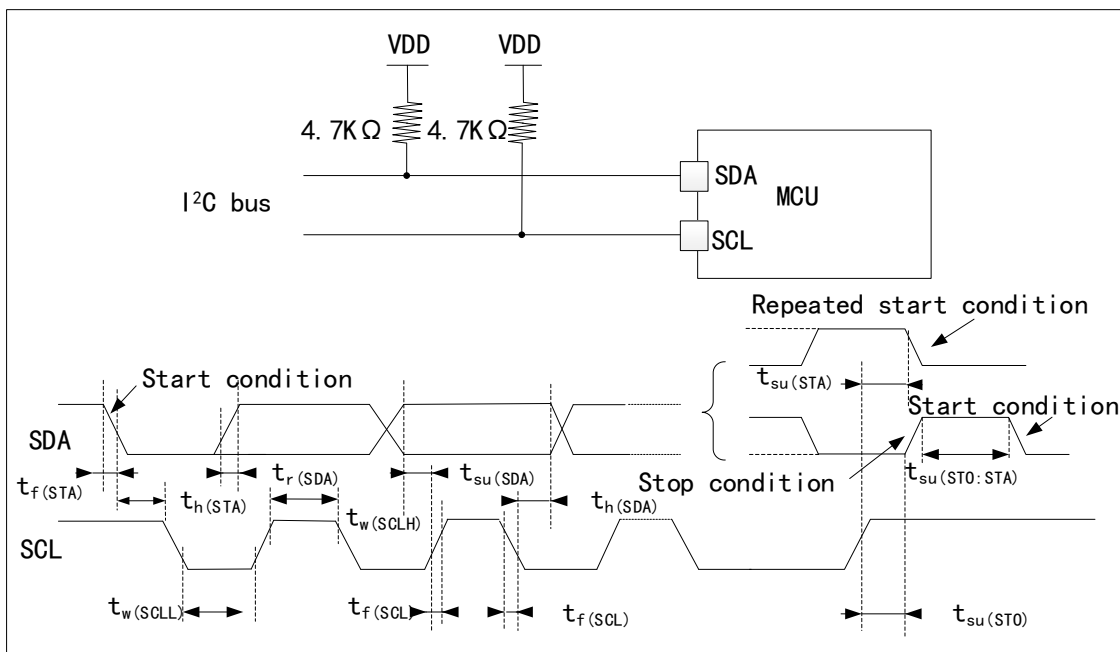

Note: The measuring points are set at CMOS levels: 0.3V_{DD} and 0.7V_{DD}.

5.11.2 SPI peripheral characteristics

Table 52 SPI Characteristics (T_A=25°C, V_{DD}=3.3V)

Symbol	Parameter	Conditions	Min	Max	Unit
f _{SCK}	SPI clock frequency	Master mode, SPI1, 2.7V<V _{DD} <3.6V	-	42	MHz
		Slave mode, SPI1, 2.7V<V _{DD} <3.6V	-	42	
1/t _{c(SCK)}		Master mode, SPI1/2/3, 1.7V<V _{DD} <3.6V	-	21	
		Slave mode, SPI1/2/3, 1.7V<V _{DD} <3.6V	-	21	
t _{r(SCK)} t _{f(SCK)}	SI clock rise and fall time	Load capacitance: C=15pF	-	6	ns
t _{su(NSS)}	NSS setup time	Slave mode	4T _{PCLK}	-	
t _{h(NSS)}	NSS hold time	Slave mode	2T _{PCLK} + 10	-	
t _{w(SCKH)} t _{w(SCKL)}	SCK high and low time	Master mode, f _{PCLK} =36MHz, Prescaler factor=4	T _{PCLK} /2-2	T _{PCLK} /2+1	
t _{su(MI)} t _{su(SI)}	Data input setup time	Master mode	4	-	
		Slave mode	5	-	
t _{h(MI)} t _{h(SI)}	Data input hold time	Master mode	4	-	
		Slave mode	5	-	

Symbol	Parameter	Conditions	Min	Max	Unit
$t_{a(SO)}$	Data output access time	Slave mode, $f_{PCLK}=20MHz$	0	$3T_{PCLK}$	
$t_{dis(SO)}$	Disable time of data output	Slave mode	0	18	
$t_{v(SO)}$	Effective time of data output	Slave mode (after enabling the edge)	-	22.5	
$t_{v(MO)}$	Effective time of data output	Master mode (after enabling the edge)	-	6.97	
$t_{h(SO)}$	Data output hold time	Slave mode (after enabling the edge)	11.5	-	
$t_{h(MO)}$		Master mode (after enabling the edge)	1	-	
$DuCy_{(SCK)}$	SPI clock frequency duty cycle	Slave mode	25	75	%

Note: The data are obtained from a comprehensive evaluation and are not tested in production.

Figure 13 SPI Timing Diagram - Slave Mode and CPHA=0

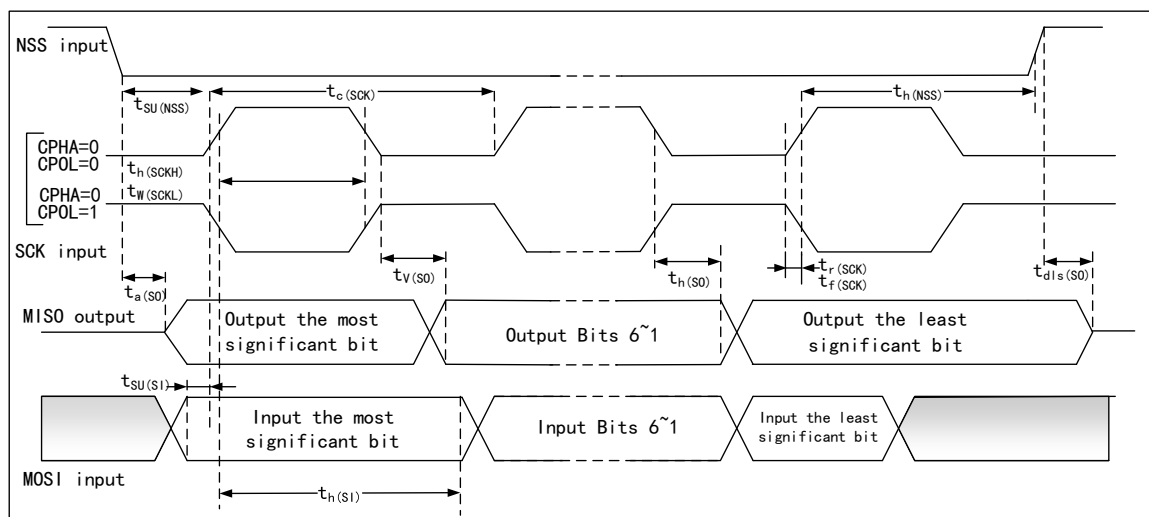
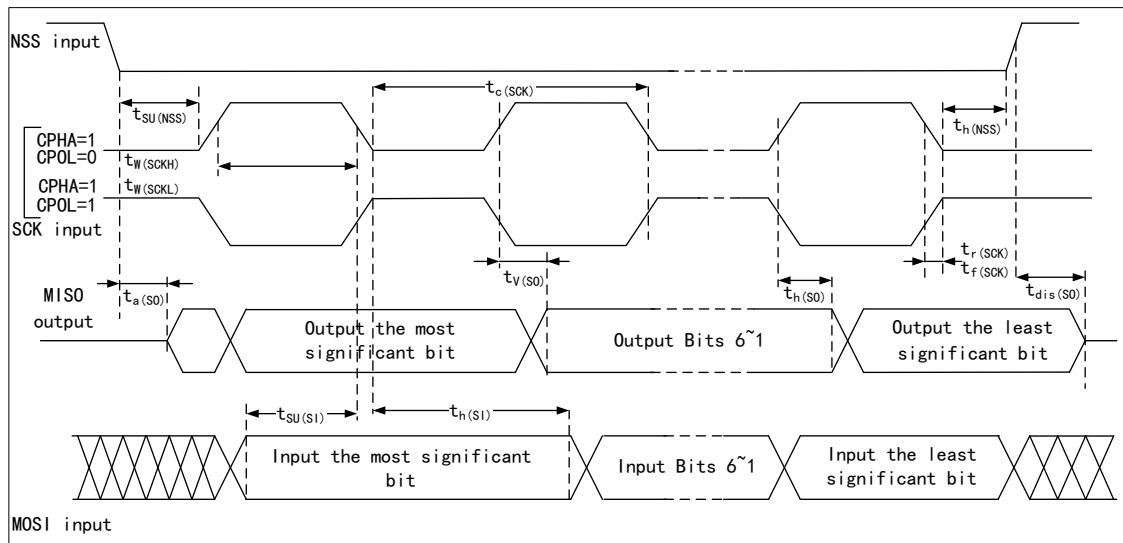
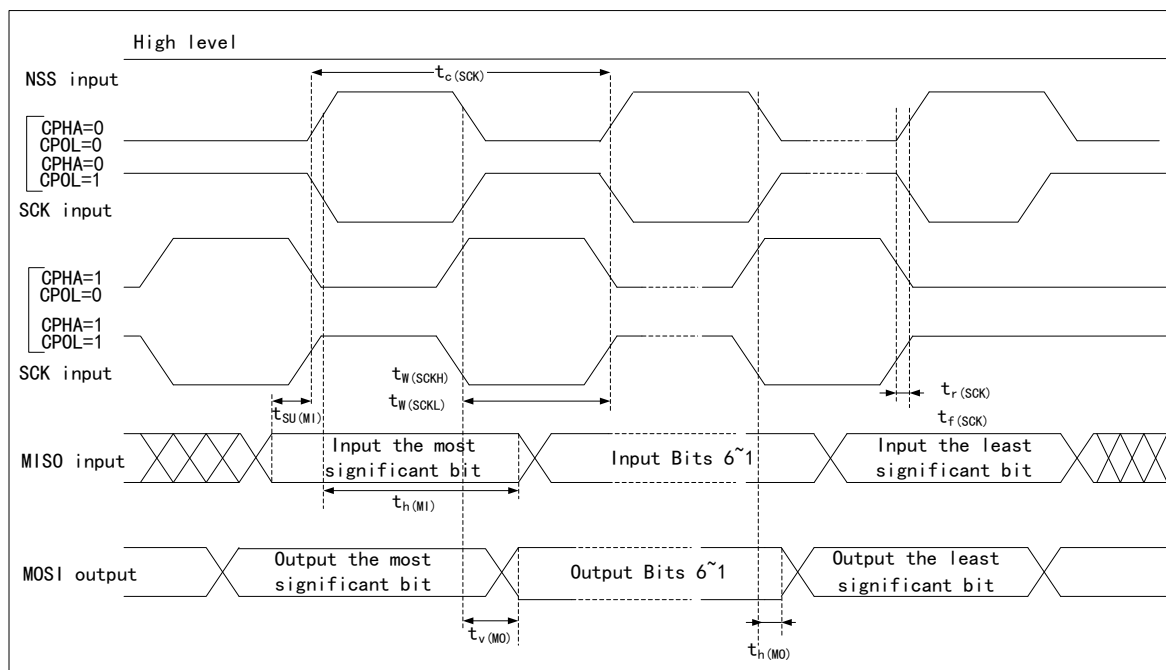

Figure 14 SPI Timing Diagram - Slave Mode and CPHA=1



Note: The measuring points are set at CMOS levels: 0.3V_{DD} and 0.7V_{DD}.

Figure 15 SPI Timing Diagram - Master Mode



Note: The measuring points are set at CMOS levels: 0.3V_{DD} and 0.7V_{DD}.

5.12 Analog peripherals

5.12.1 ADC

Test parameter description:

- Sampling rate: the number of conversion of analog quantity to digital quantity by ADC per second
- Sample rate=ADC clock/(number of sampling periods + number of conversion periods)

5.12.1.1 12-bit ADC characteristics

Table 53 12-bit ADC Characteristics

Symbol	Parameter	Conditions	Min	Typ	Max	Unit
V_{DDA}	Power supply voltage	-	1.8	-	3.6	V
I_{DDA}	ADC power consumption	-	-	1.6	1.8	mA
f_{ADC}	ADC frequency	$V_{DDA}=1.8\sim 2.4V$	0.6	15	18	MHz
		$V_{DDA}=2.4\sim 3.6V$	0.6	30	36	
C_{ADC}	Internal sampling and holding capacitance	-	-	4	-	pF
R_{ADC}	Sampling resistor	-	-	-	6000	Ω
t_s	Sampling time	$f_{ADC}=30MHz$	0.1	-	16	μs
		-	3	-	480	$1/f_{ADC}$
T_{CONV}	Sampling and conversion time	$f_{ADC}=30MHz$ 12-bit resolution	0.50	-	16.40	μs
		$f_{ADC}=30MHz$ 10-bit resolution	0.43	-	16.34	μs
		$f_{ADC}=30MHz$ 8-bit resolution	0.37	-	16.27	μs
		$f_{ADC}=30MHz$ 6-bit resolution	0.30	-	16.20	μs
I_{Vref}	ADC VREF DC current consumption in conversion mode	-	-	300	500	μA

Table 54 12-bit ADC Accuracy

Symbol	Parameter	Conditions	Typ	Max	Unit
E_T	Composite error	$f_{PCLK}=56MHz,$ $f_{ADC}=14MHz,$ $V_{DDA}=2.4V\sim 3.6V$ $T_A=-40^{\circ}C\sim 105^{\circ}C$	± 2	± 5	LSB
E_O	Offset error		± 1.5	± 2.5	
E_G	Gain error		± 1.5	± 3	
E_D	Differential linear error		± 1	± 2	
E_L	Integral linear error		± 1.5	± 3	

Note: The data are obtained from a comprehensive evaluation and are not tested in production.

5.12.1.2 Temperature Sensor Characteristics

Table 55 Temperature Sensor Characteristics

Symbol	Parameter	Minimum value	Typical value	Maximum value	Unit
Slope(1)	Average slope($V_{DD} = 3.3V$, $T_A = -40 \sim 85^{\circ}C$)	-	2.47	-	mV/ $^{\circ}C$
V25	Vaoltage in $25^{\circ}C$ ($V_{DD} = 2.0-3.6V$)	-	0.76	-	V
TS_temp(2)	ADC sampling time when reading temperature	10	-	-	μs

Note: (1) It is guaranteed by design and will not be tested in production.

(2) The minimum sampling time can be determined by the application through multiple loops.

5.12.1.3 Test of Built-in Reference Voltage Characteristics

Table 56 Built-in Reference Voltage Characteristics

Symbol	Parameter	Conditions	Min	Typ	Max	Unit
V_{REFINT}	Built-in Reference Voltage	$-40^{\circ}C < T_A < +105^{\circ}C$	1.19	1.20	1.20	V
$T_{S_vrefint}$	Sampling time of ADC when reading out internal reference voltage	-	10	-	-	μs
V_{RERINT}	Built-in reference voltage extends to temperature range	$V_{DD}=3V$	-	3	5	mV
T_{coeff}	Temperature coefficient	-	-	30	50	ppm/ $^{\circ}C$

Note: The data are obtained from a comprehensive evaluation and are not tested in production.

5.12.2 DAC

Test parameter description:

- DNL differential non-linear error: the deviation between two consecutive codes minus 1LSB
- INL integral non-linear error: the difference between the measured value at code i and the value at code i on the connection between code 0 and the last code 4095

Table 57 DAC Characteristics

Symbol	Parameter	Conditions	Min	Typ	Max	Unit
V_{DDA}	Analog power supply voltage	-	1.8	-	3.6	V
R_{LOAD}	Resistive load	The buffer is turned on	5	-	-	k Ω
R_O	Output impedance	The resistive load between DAC_OUT and V_{SS} is 1.5M Ω with buffer off	-	-	15	k Ω
C_{LOAD}	Capacitive load	Maximum capacitive load at DAC_OUT pin with buffer on	-	-	50	pF
DAC_OUT min	Low DAC_OUT voltage with buffer	Maximum output offset of DAC, (0x0E0) corresponding to 12-bit input	0.2	-	-	V

Symbol	Parameter	Conditions	Min	Typ	Max	Unit
DAC_OUT max	Higher DAC_OUT voltage with buffer	code to V_{REF+} (0xF1C) at 3.6V and V_{REF+} (0x1C7) at 1.8V and (0xE38)	-	-	$V_{DDA}-0.2$	V
DAC_OUT min	Low DAC_OUT voltage without buffer	Maximum output offset of DAC	-	0.5	-	mV
DAC_OUT max	Higher DAC_OUT voltage without buffer		-	-	V_{REF+} - 1LSB	V
DNL	Differential non- linear error	Configured with 12-bit DAC	-	-	± 2	LSB
INL	Integral non-linear error	Configured with 12-bit DAC	-	-	± 4	LSB
Offset	Offset error	$V_{REF+}=3.6V$, configuring 12-bit DAC	-	-	± 12	LSB
Gain error	Gain error	Configured with 12-bit DAC	-	-	± 0.5	%

Note: The data are obtained from a comprehensive evaluation and are not tested in production.

6 Package Information

6.1 LQFP176 package information

Figure 16 LQFP176 Package Diagram

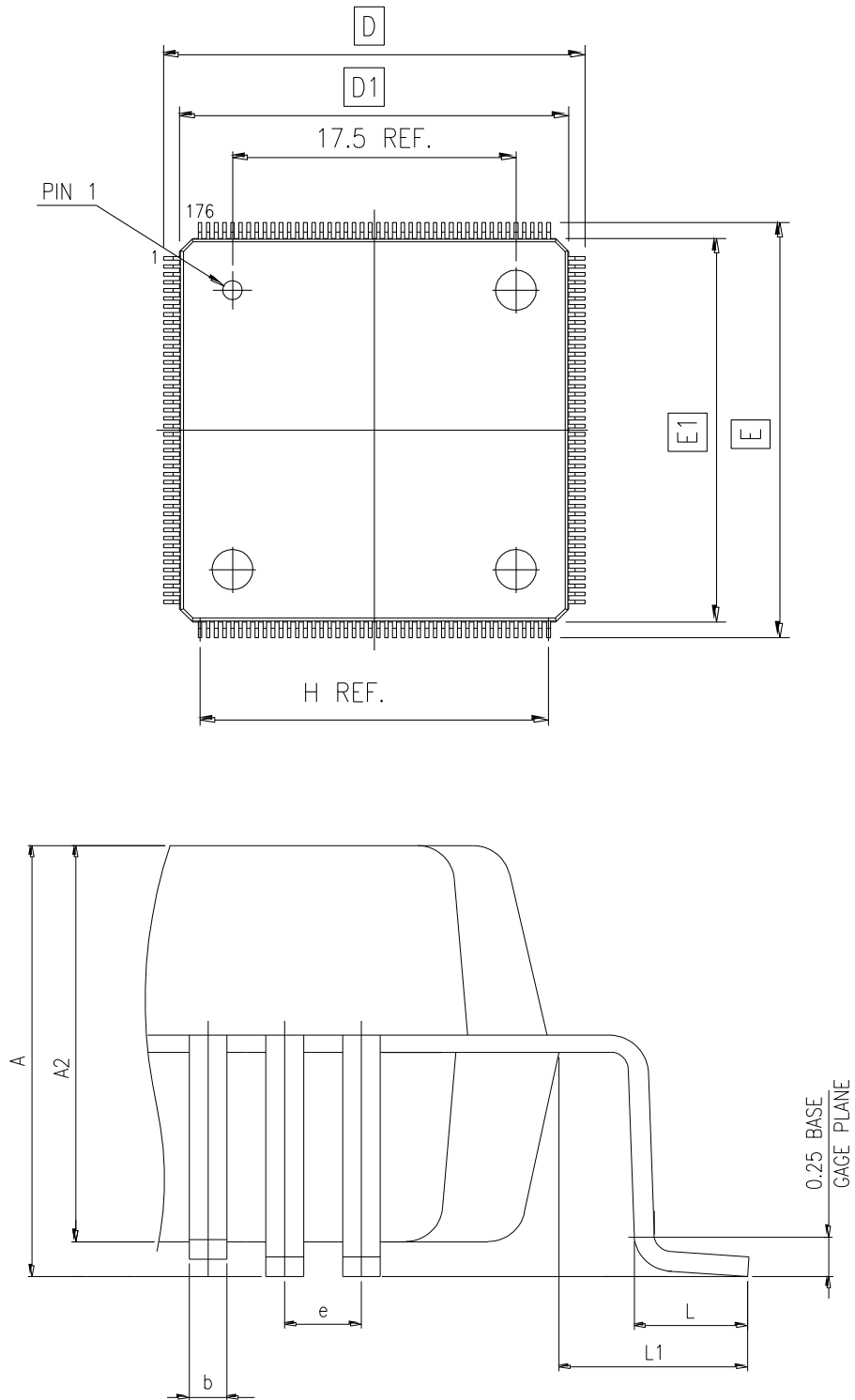

- (1) The figure is not drawn to scale.
- (2) All pins should be soldered to the PCB.

Table 58 LQFP176 Package Data

S/N	SYM	DIMENSIONS	REMARKS
1	A	MAX. 1.600	OVERALL HEIGHT
2	A2	1.400±0.050	PKG THICKNESS
3	D	26.000±0.200	LEAD TIP TO TIP
4	D1	24.000±0.100	PKG LENGTH
5	E	26.000±0.200	LEAD TIP TO TIP
6	E1	24.000±0.100	PKG WIDTH
7	L	0.600±0.150	FOOT LENGTH
8	L1	1.000 REF	LEAD LENGTH
9	e	0.500 BASE	LEAD PITCH
10	H (REF)	(21.50)	CUM LEAD PITCH
11	b	0.22±0.050	LEAD WIDTH

Note: Dimensions are marked in millimeters.

Figure 17 LQFP176 -176 Pins, 24 x24mm Welding Layout Recommendations

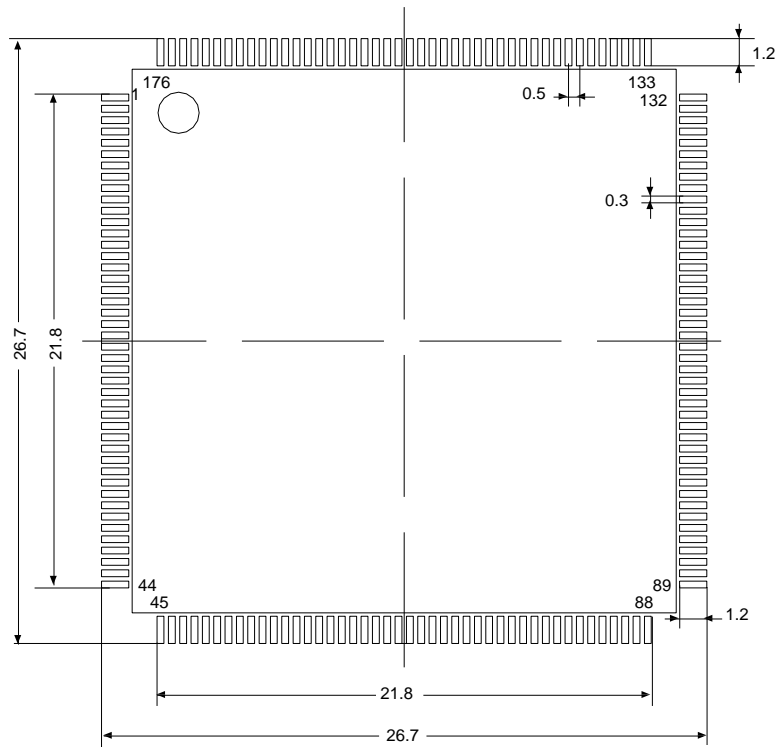
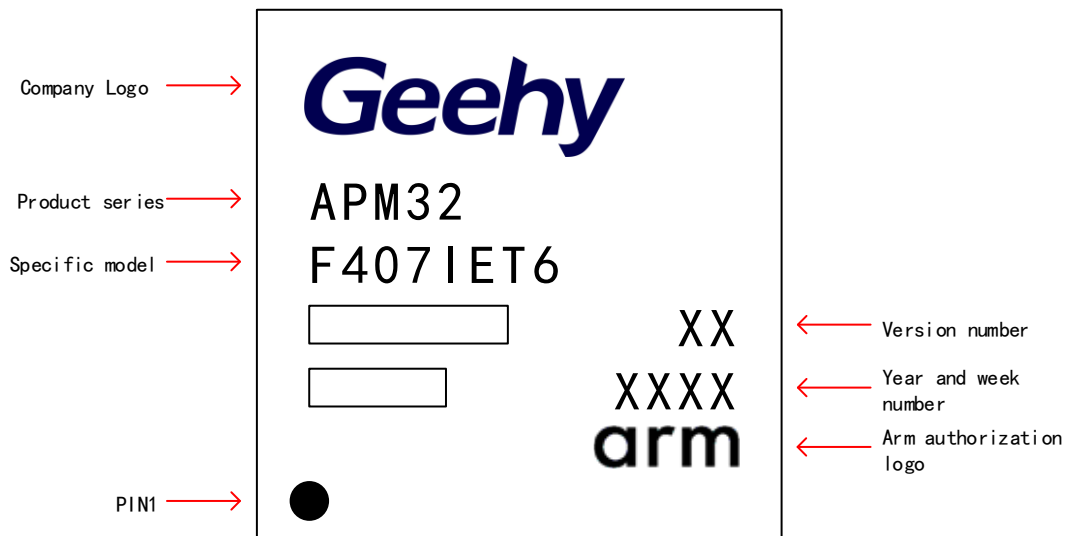
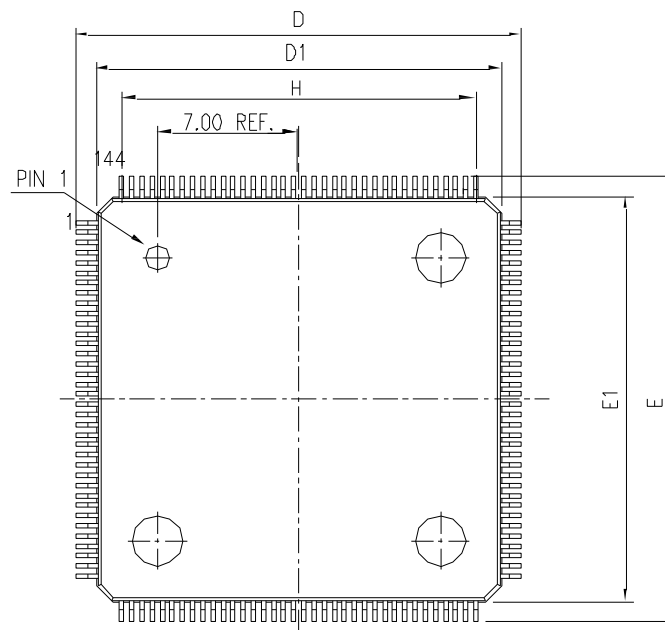

Figure 18 LQFP176 -176 Pins, 24 x24mm Schematic Diagram



6.2 LQFP144 package information

Figure 19 LQFP144 Package Diagram



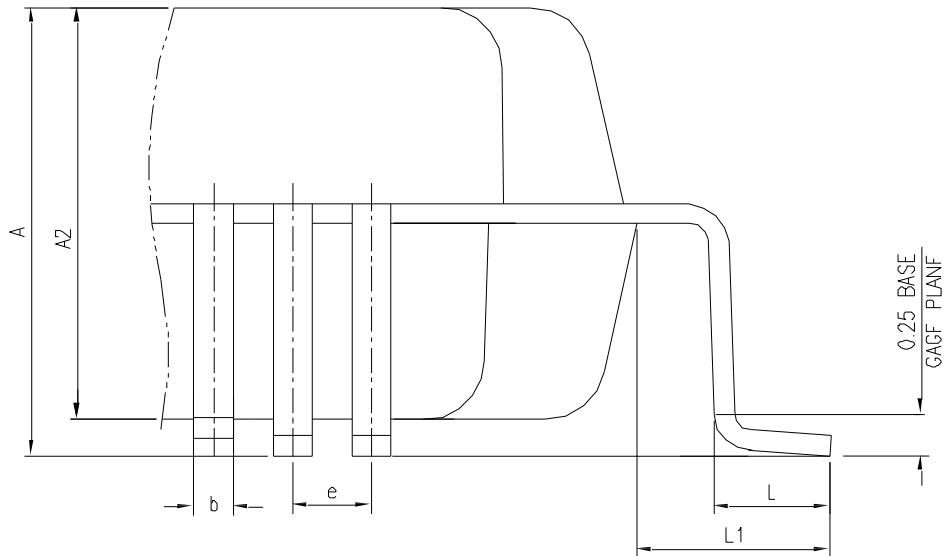

- (1) The figure is not drawn to scale.
- (2) All pins should be soldered to the PCB.

Table 59 LQFP144 Package Data

S/N	SYM	DIMENSIONS	REMARKS
1	A	MAX. 1.600	OVERALL HEIGHT
2	A2	1.400±0.050	PKG THICKNESS
3	D	22.000±0.200	LEAD TIP TO TIP
4	D1	20.000±0.100	PKG LENGTH
5	E	22.000±0.200	LEAD TIP TO TIP
6	E1	20.000±0.100	PKG WIDTH
7	L	0.600±0.150	FOOT LENGTH
8	L1	1.000 REF	LEAD LENGTH
9	e	0.500 BASE	LEAD PITCH
10	H (REF)	(17.50)	CUM LEAD PITCH
11	b	0.22±0.050	LEAD WIDTH

Note: Dimensions are marked in millimeters.

Figure 20 LQFP144-144 Pins, 20 x 20mm Welding Layout Recommendations

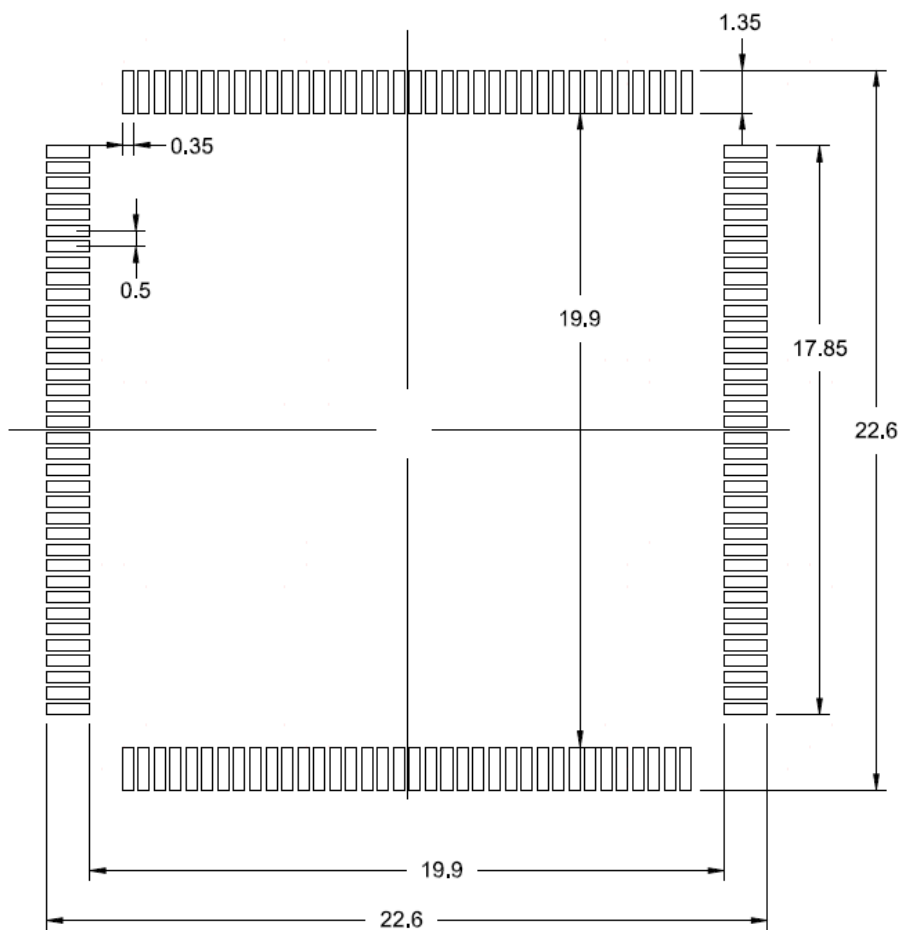

Note: Dimensions are marked in millimeters.

Figure 21 LQFP144 -144 Pins, 20 x20mm Schematic Diagram

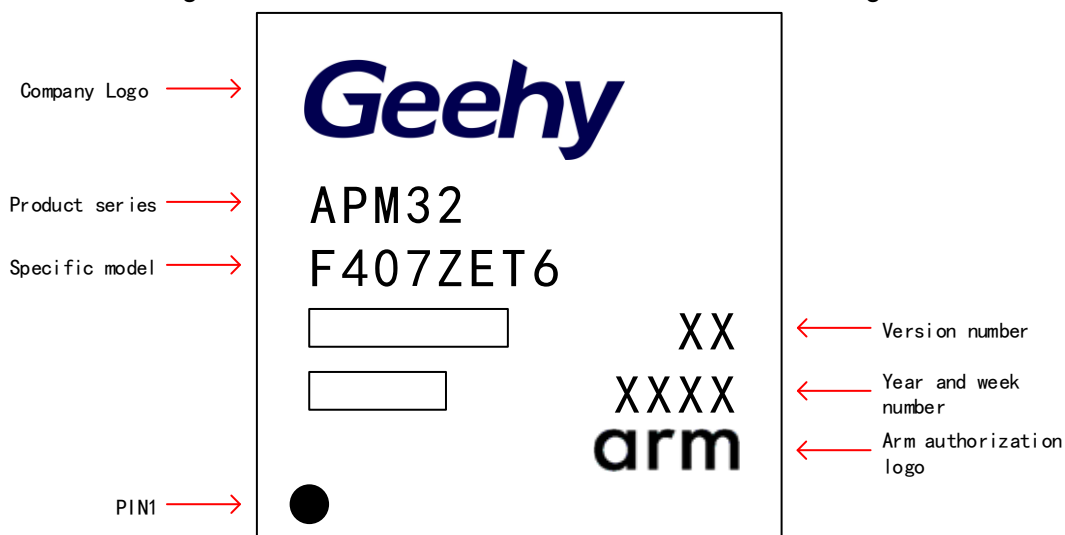

6.3 LQFP100 package information

Figure 22 LQFP100 Package Diagram

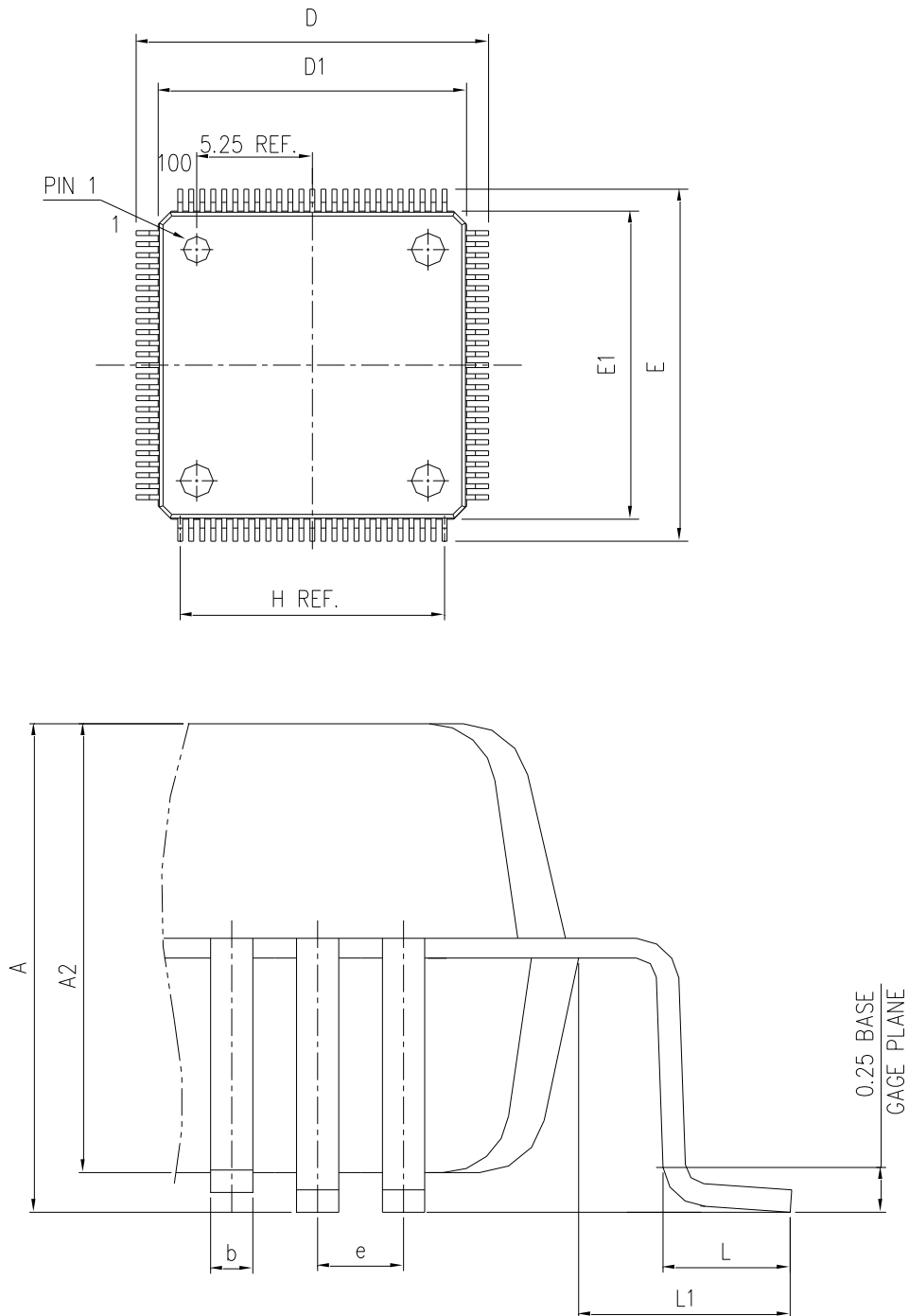

- (1) The figure is not drawn to scale.
- (2) All pins should be soldered to the PCB.

Table 60 LQFP100 Package Data

DIMENSION LIST (FOOTPRINT: 2.00)			
S/N	SYM	DIMENSIONS	REMARKS
1	A	MAX. 1.600	OVERALL HEIGHT
2	A2	1.400±0.050	PKG THICKNESS
3	D	16.000±0.200	LEAD TIP TO TIP
4	D1	14.000±0.100	PKG LENGTH
5	E	16.000±0.200	LEAD TIP TO TIP
6	E1	14.000±0.100	PKG WDTH
7	L	0.600±0.150	FOOT LENGTH
8	L1	1.000 REF	LEAD LENGTH
9	e	0.500 BASE	LEAD PITCH
10	H (REF)	(12.00)	CUM LEAD PITCH
11	b	0.22±0.050	LEAD WIDTH

Note: Dimensions are marked in millimeters.

Figure 23 LQFP100 - 100 Pins, 14 x 14mm Welding Layout Recommendations

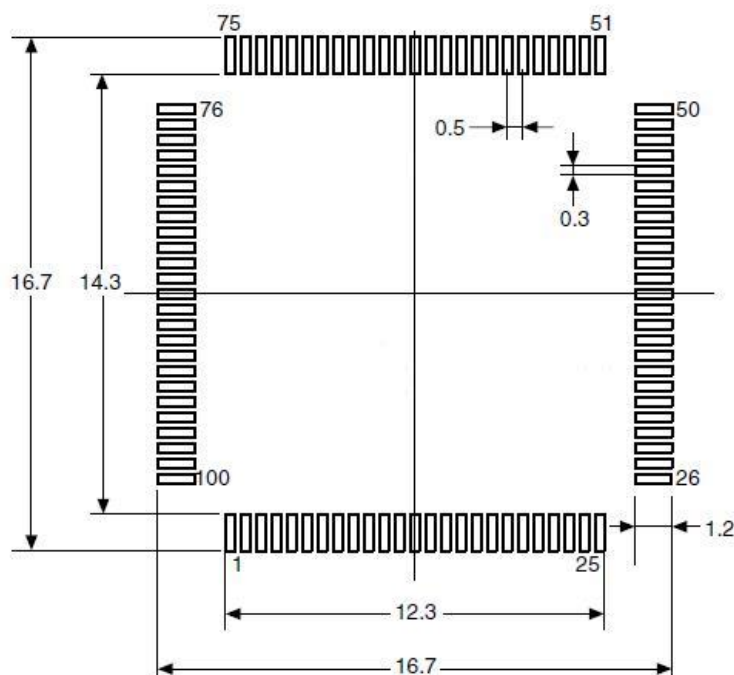

Note: Dimensions are marked in millimeters.

Figure 24 LQFP100 - 100 Pins, 14 x 14mm Package Schematic Diagram

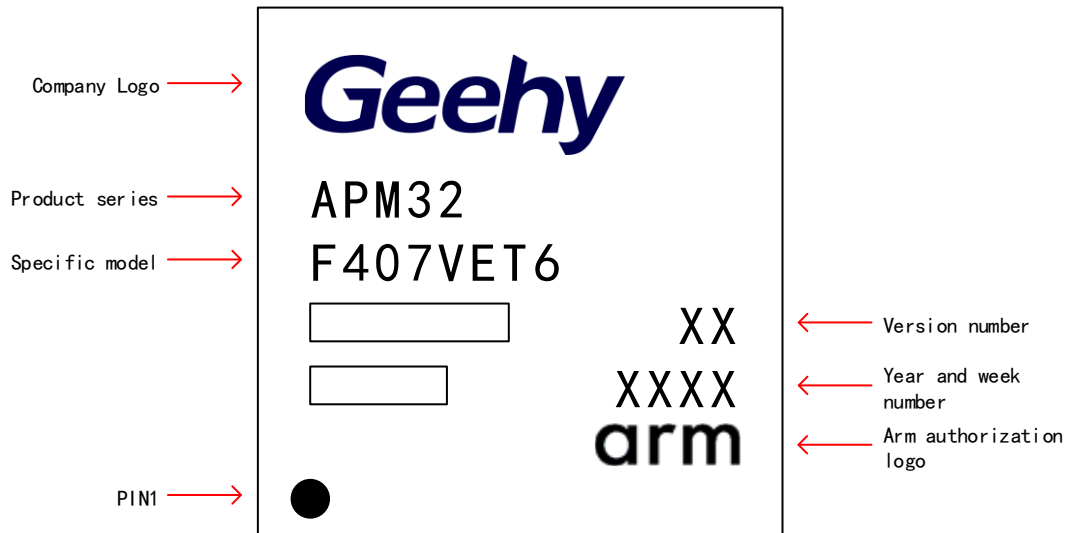

6.4 LQFP64 package information

Figure 25 LQFP64 Package Diagram

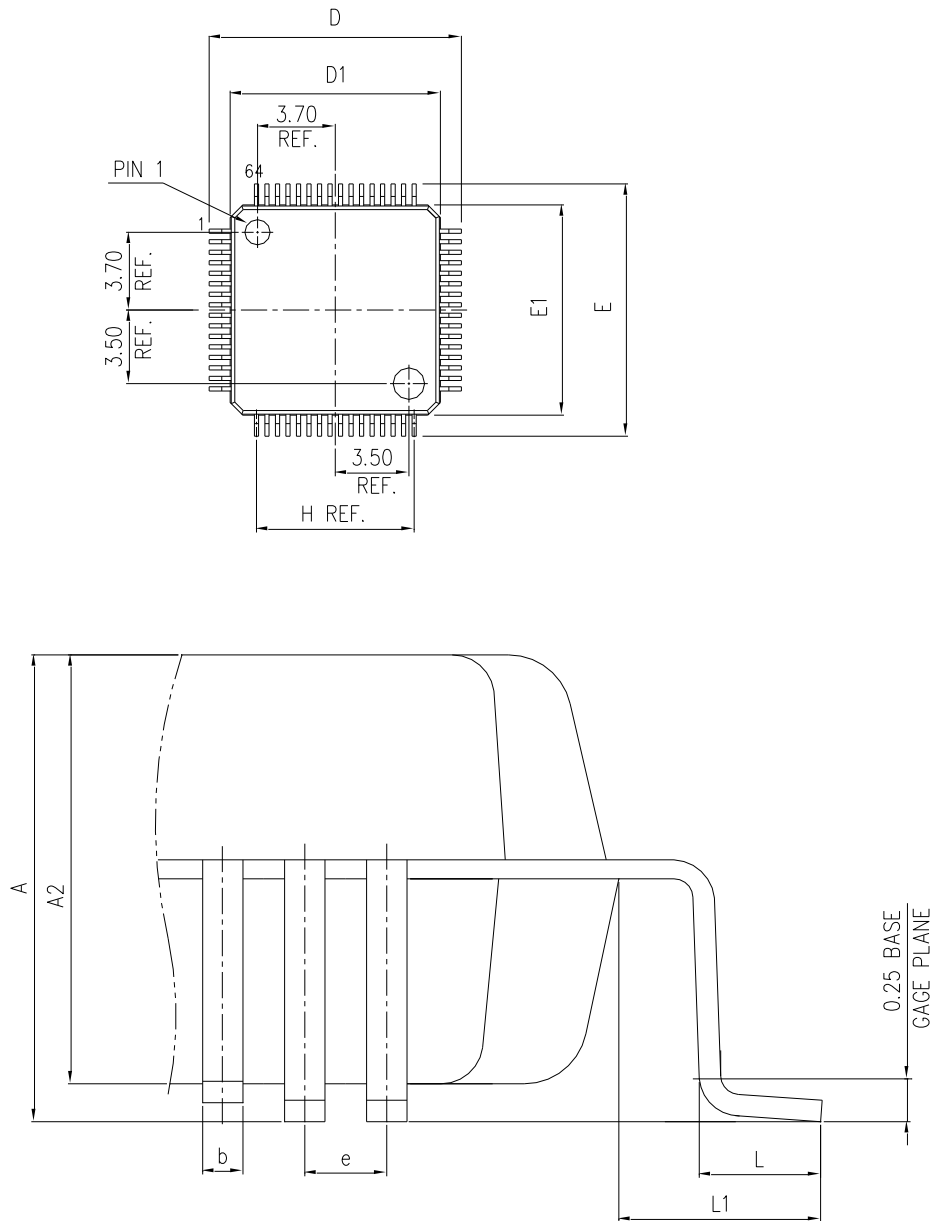

- (1) The figure is not drawn to scale.
- (2) All pins should be soldered to the PCB.

Table 61 LQFP64 Package Data

S/N	SYM	DIMENSIONS	REMARKS
1	A	MAX.1.600	OVERALLHEIGHT
2	A2	1.400±0.050	PKGTHICKNESS
3	D	12.000±0.200	LEADTIPTOTIP
4	D1	10.000±0.100	PKGLENGTH
5	E	12.000±0.200	LEADTIPTOTIP
6	E1	10.000±0.100	PKGWIDTH
7	L	0.600±0.150	FOOTLENGTH
8	L1	1.000REF.	LEADLENGTH
9	e	0.500BASE	LEADPITCH
10	H(REF.)	(7.500)	GUM.LEADPITCH
11	b	0.220±0.050	LEADWIDTH

Note: Dimensions are marked in millimeters.

Figure 26 LQFP64 Welding Layout Recommendations

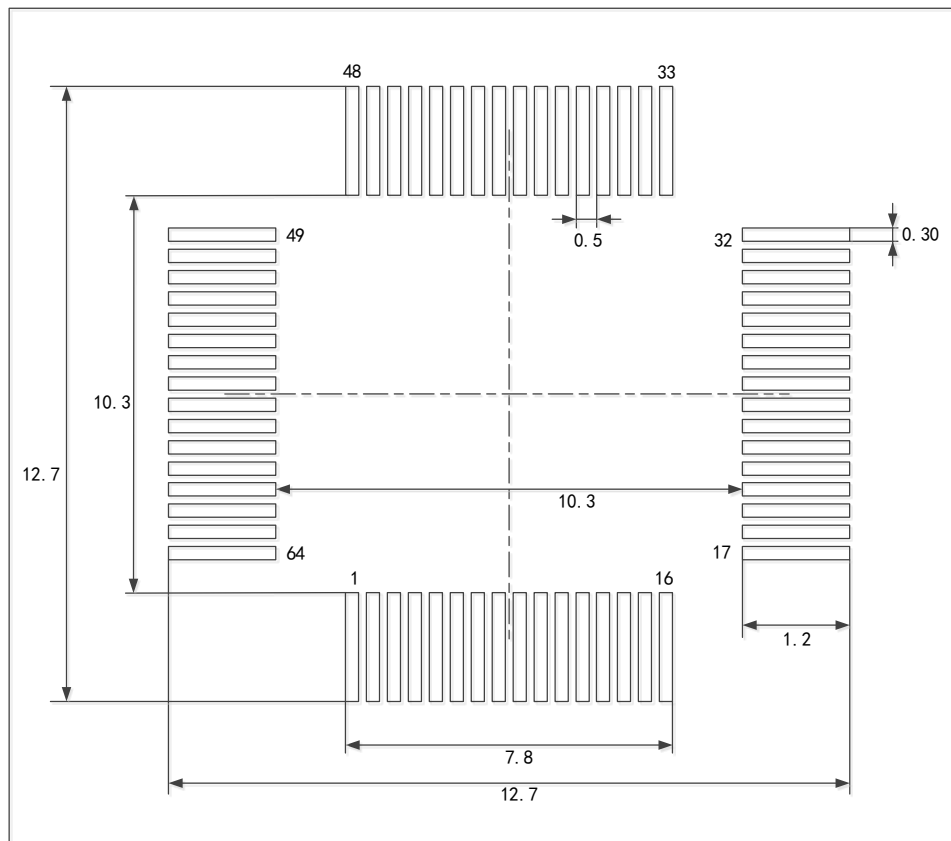

Note: Dimensions are marked in millimeters.

Figure 27 LQFP64 - 64 Pins, 10 x 10mm Package Schematic Diagram

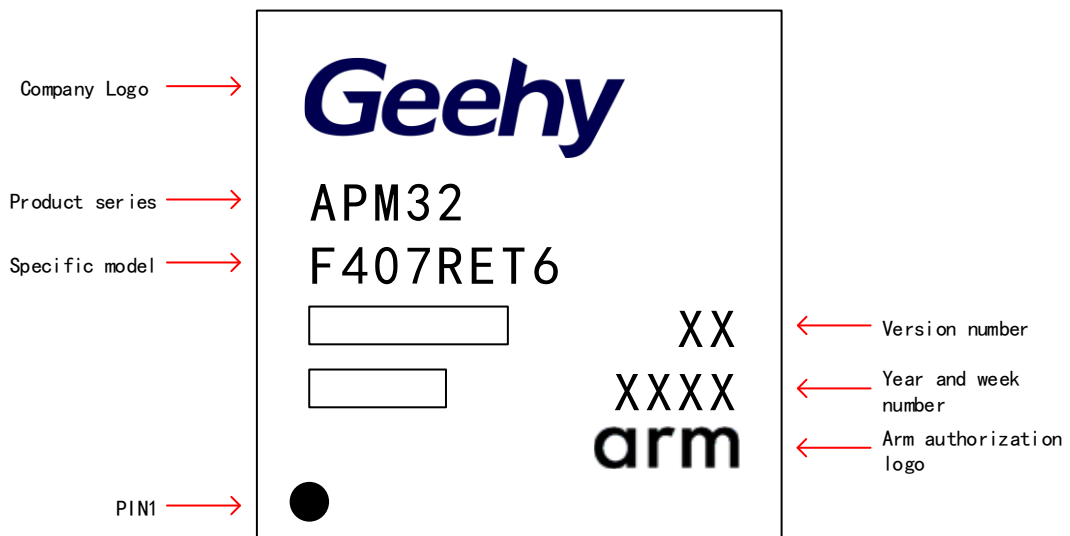

7 Packaging Information

7.1 Reel packaging

Figure 28 Specification Drawing of Reel Packaging

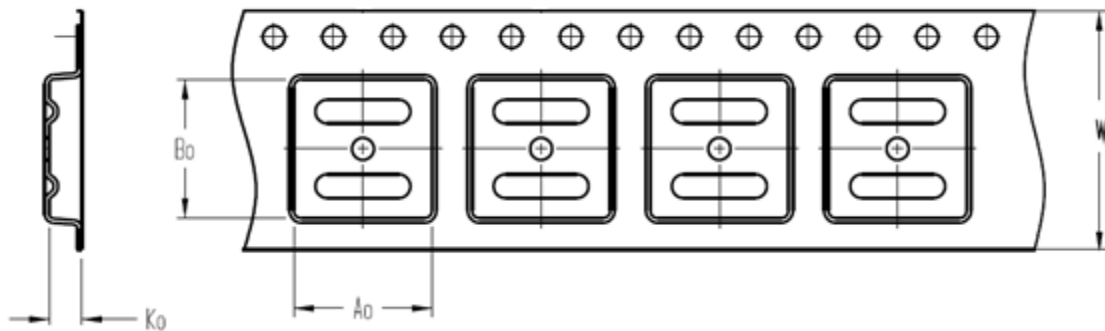

A0	Dimension designed to accommodate the component width
B0	Dimension designed to accommodate the component length
K0	Dimension designed to accommodate the component thickness
W	Overall width of the carrier tape

Quadrant Assignments for PIN1 Orientation in Tape

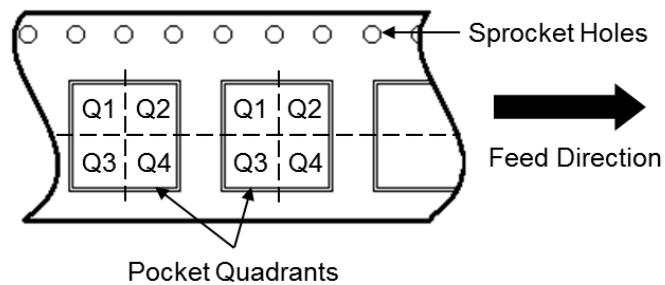

Reel Dimensions

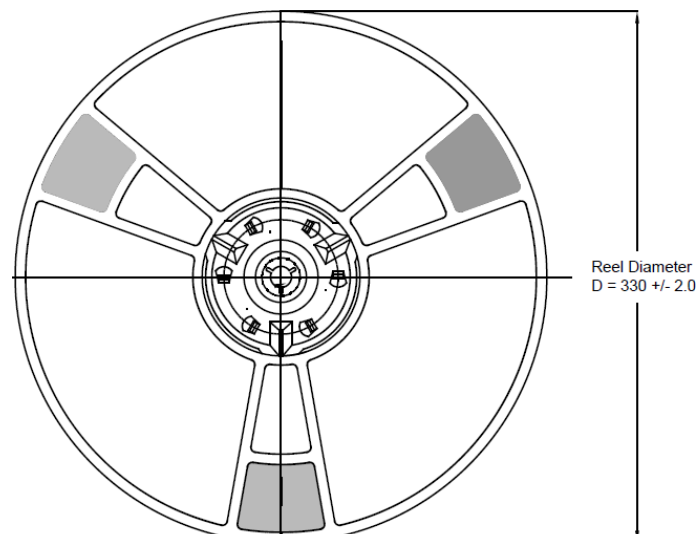

All photos are for reference only, and the appearance is subject to the product.

Table 62 Reel Packaging Parameter Specification Table

Device	Package Type	Pins	SPQ	Reel Diameter (mm)	A0 (mm)	B0 (mm)	K0 (mm)	W (mm)	Pin1 Quadrant
APM32F407RET6	LQFP	64	1000	330	12.35	12.35	2.2	24	Q1
APM32F407RGT6	LQFP	64	1000	330	12.35	12.35	2.2	24	Q1
APM32F405RGT6	LQFP	64	1000	330	12.35	12.35	2.2	24	Q1
APM32F407RET7	LQFP	64	1000	330	12.35	12.35	2.2	24	Q1
APM32F407RGT7	LQFP	64	1000	330	12.35	12.35	2.2	24	Q1
APM32F405RGT7	LQFP	64	1000	330	12.35	12.35	2.2	24	Q1

7.2 Tray packaging

Figure 29 Tray Packaging Diagram

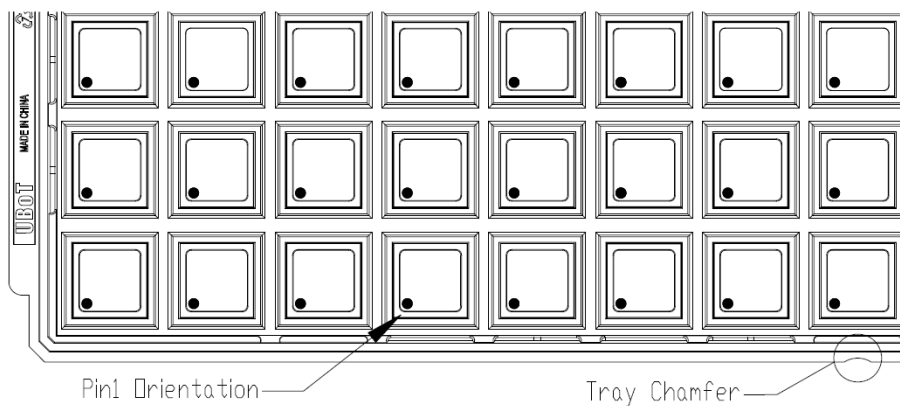

Tray Dimensions

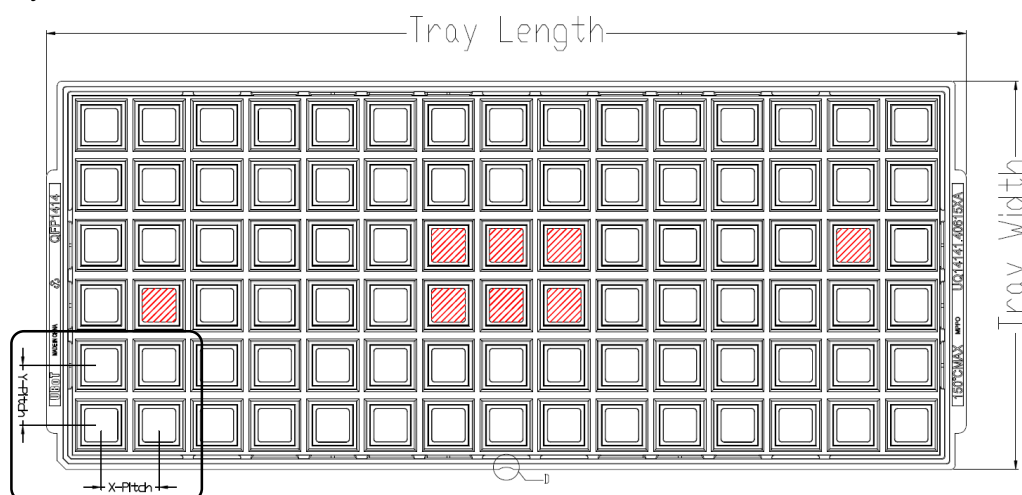

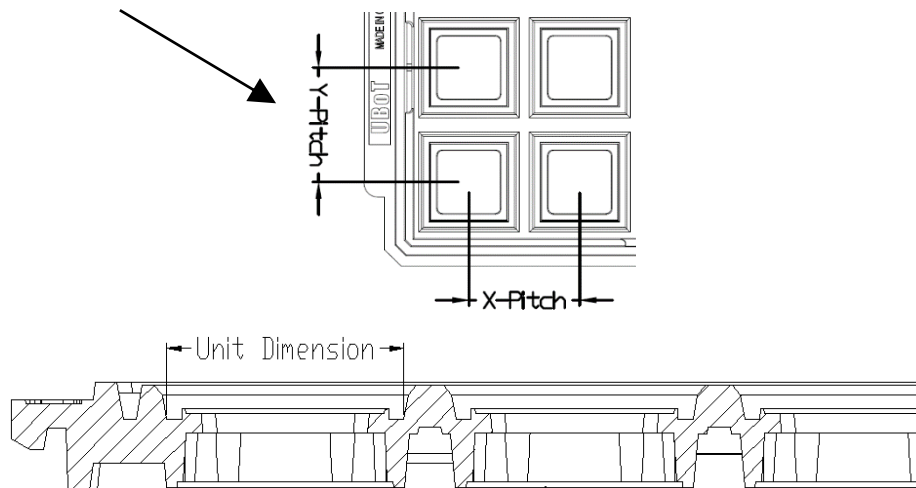

All photos are for reference only, and the appearance is subject to the product

Table 63 Tray Packaging Parameter Specification Table

Device	Package Type	Pins	SPQ	X-Dimension (mm)	Y-Dimension (mm)	X-Pitch (mm)	Y-Pitch (mm)	Tray Length (mm)	Tray Width (mm)
APM32F407IET6	LQFP	176	400	27	27	30.4	31.5	322.6	135.9
APM32F407IGT6	LQFP	176	400	27	27	30.4	31.5	322.6	135.9
APM32F407ZET6	LQFP	144	600	22.06	22.06	25.4	25.2	322.6	135.9
APM32F407ZGT6	LQFP	144	600	22.06	22.06	25.4	25.2	322.6	135.9
APM32F407VET6	LQFP	100	900	16.6	16.6	20.3	21	322.6	135.9
APM32F407VGT6	LQFP	100	900	16.6	16.6	20.3	21	322.6	135.9
APM32F407RET6	LQFP	64	1600	12.3	12.3	15.2	15.7	322.6	135.9
APM32F407RGT6	LQFP	64	1600	12.3	12.3	15.2	15.7	322.6	135.9
APM32F405ZGT6	LQFP	144	600	22.06	22.06	25.4	25.2	322.6	135.9
APM32F405VGT6	LQFP	100	900	16.6	16.6	20.3	21	322.6	135.9
APM32F405RGT6	LQFP	64	1600	12.3	12.3	15.2	15.7	322.6	135.9
APM32F407IET7	LQFP	176	400	27	27	30.4	31.5	322.6	135.9
APM32F407IGT7	LQFP	176	400	27	27	30.4	31.5	322.6	135.9
APM32F407ZET7	LQFP	144	600	22.06	22.06	25.4	25.2	322.6	135.9
APM32F407ZGT7	LQFP	144	600	22.06	22.06	25.4	25.2	322.6	135.9
APM32F407VET7	LQFP	100	900	16.6	16.6	20.3	21	322.6	135.9
APM32F407VGT7	LQFP	100	900	16.6	16.6	20.3	21	322.6	135.9
APM32F407RET7	LQFP	64	1600	12.3	12.3	15.2	15.7	322.6	135.9
APM32F407RGT7	LQFP	64	1600	12.3	12.3	15.2	15.7	322.6	135.9
APM32F405ZGT7	LQFP	144	600	22.06	22.06	25.4	25.2	322.6	135.9
APM32F405VGT7	LQFP	100	900	16.6	16.6	20.3	21	322.6	135.9
APM32F405RGT7	LQFP	64	1600	12.3	12.3	15.2	15.7	322.6	135.9

8 Ordering Information

Figure 30 APM32F405xG 407xExG Series Ordering Information Diagram

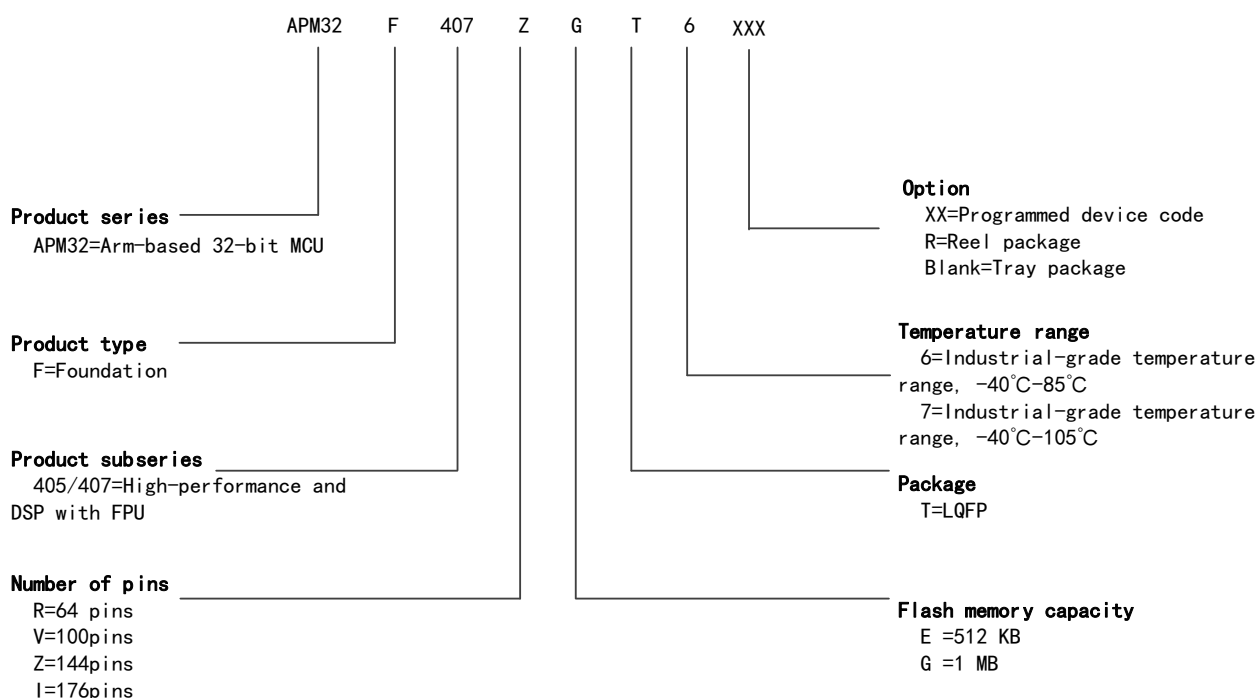

Table 64 Ordering Information Table

Order code	FLASH (KB)	SRAM (KB)	Package	SPQ	Range of temperature
APM32F407IGT6	1024	192+4	LQFP176	400	Industrial grade -40°C~85°C
APM32F407IET6	512	192+4	LQFP176	400	Industrial grade -40°C~85°C
APM32F407ZGT6	1024	192+4	LQFP144	600	Industrial grade -40°C~85°C
APM32F407ZET6	512	192+4	LQFP144	600	Industrial grade -40°C~85°C
APM32F407VGT6	1024	192+4	LQFP100	900	Industrial grade -40°C~85°C
APM32F407VET6	512	192+4	LQFP100	900	Industrial grade -40°C~85°C
APM32F407RGT6	1024	192+4	LQFP64	1600	Industrial grade -40°C~85°C
APM32F407RET6	512	192+4	LQFP64	1600	Industrial grade -40°C~85°C
APM32F407RGT6-R	1024	192+4	LQFP64	1000	Industrial grade -40°C~85°C
APM32F407RET6-R	512	192+4	LQFP64	1000	Industrial grade -40°C~85°C
APM32F405ZGT6	1024	192+4	LQFP144	600	Industrial grade -40°C~85°C
APM32F405VGT6	1024	192+4	LQFP100	900	Industrial grade -40°C~85°C
APM32F407RGT6	1024	192+4	LQFP64	1600	Industrial grade -40°C~85°C
APM32F405RGT6-R	1024	192+4	LQFP64	1000	Industrial grade -40°C~85°C
APM32F407IGT7	1024	192+4	LQFP176	400	Industrial grade -40°C~105°C
APM32F407IET7	512	192+4	LQFP176	400	Industrial grade -40°C~105°C
APM32F407ZGT7	1024	192+4	LQFP144	600	Industrial grade -40°C~105°C
APM32F407ZET7	512	192+4	LQFP144	600	Industrial grade -40°C~105°C

Order code	FLASH (KB)	SRAM (KB)	Package	SPQ	Range of temperature
APM32F407VGT7	1024	192+4	LQFP100	900	Industrial grade -40°C~105°C
APM32F407VET7	512	192+4	LQFP100	900	Industrial grade -40°C~105°C
APM32F407RGT7	1024	192+4	LQFP64	1600	Industrial grade -40°C~105°C
APM32F407RET7	512	192+4	LQFP64	1600	Industrial grade -40°C~105°C
APM32F407RGT7-R	1024	192+4	LQFP64	1000	Industrial grade -40°C~105°C
APM32F407RET7-R	512	192+4	LQFP64	1000	Industrial grade -40°C~105°C
APM32F405ZGT7	1024	192+4	LQFP144	600	Industrial grade -40°C~105°C
APM32F405VGT7	1024	192+4	LQFP100	900	Industrial grade -40°C~105°C
APM32F407RGT7	1024	192+4	LQFP64	1600	Industrial grade -40°C~105°C
APM32F405RGT7-R	1024	192+4	LQFP64	1000	Industrial grade -40°C~105°C

9 Commonly Used Function Module Denomination

Table 65 Commonly Used Function Module Denomination

Full name	Abbreviations
Reset management unit	RMU
Clock management unit	CMU
Reset and clock management	RCM
External interrupt	EINT
General-purpose IO	GPIO
Multiplexing IO	AFIO
Wake-up controller	WUPT
Buzzer	BUZZER
Independent watchdog timer	IWDT
Window watchdog timer	WWDT
Timer	TMR
CRC controller	CRC
Power Management Unit	PMU
DMA controller	DMA
Analog-to-digital converter	ADC
Real-time clock	RTC
External memory controller	EMMC
Controller local area network	CAN
I2C Interface	I2C
Serial peripheral interface	SPI
Universal asynchronous transmitter receiver	UART
Universal synchronous and asynchronous transmitter receiver	USART
Flash interface control unit	FMC

10 Version History

Table 66 Document Version History

Date	Version	Change History
2021.10	1.0	New creation
2022.4.1	1.1	(1) Modify pin definitions (2) The APM32F405xG model is added
2022.7.12	1.2	(1) Add 3.3 GPIO Multiplexing Function Configuration (2) Modify the Arm trademark (3) Add the statement (4) Add DMC pin description
2022.8.5	1.3	(1) Modified SPI electrical parameters (2) Increase the order code (3) Modify Clock Tree
2022.9.21	1.4	(1) Modify GPIOB multiplexing function configuration table
2023.1.16	1.5	(1) Modify the manual version to apply to chip version A (2) Add HSECLK oscillator transconductance G_m parameter (3) Add ADC Vref DC power consumption data (4) Add the order code for T7 (5) Modify the ESD parameters (6) Modify the Pin function description (7) Add the internal reference voltage and Tsensor calibration value (8) Modify the description of NVIC function (9) Modify address mapping and timer format (10) Modify GPIOF/G/H address mapping
2023.11.9	1.6	(1) Delete BAKPR information in "Peripheral power consumption" (2) Delete product information ADC internal channel description, modify ADC content description (3) Change Cortex-M4 in the document to: Cortex-M4F (4) Add chapter 5.12.1.12 "Temperature sensor characteristics" (5) Add Ethernet description to product features (6) Modify the I/O structure of PB5 pin and the number of FT input I/Os (7) Modify TMR9/10/11/12/13/14 counter type
2023.11.23	1.7	(1) Add address mapping for OTP area, modify option byte area range

Statement

This document is formulated and published by Geehy Semiconductor Co., Ltd. (hereinafter referred to as “Geehy”). The contents in this document are protected by laws and regulations of trademark, copyright and software copyright. Geehy reserves the right to make corrections and modifications to this document at any time. Please read this document carefully before using Geehy products. Once you use the Geehy product, it means that you (hereinafter referred to as the “users”) have known and accepted all the contents of this document. Users shall use the Geehy product in accordance with relevant laws and regulations and the requirements of this document.

1. Ownership

This document can only be used in connection with the corresponding chip products or software products provided by Geehy. Without the prior permission of Geehy, no unit or individual may copy, transcribe, modify, edit or disseminate all or part of the contents of this document for any reason or in any form.

The “极海” or “Geehy” words or graphics with “®” or “™” in this document are trademarks of Geehy. Other product or service names displayed on Geehy products are the property of their respective owners.

2. No Intellectual Property License

Geehy owns all rights, ownership and intellectual property rights involved in this document.

Geehy shall not be deemed to grant the license or right of any intellectual property to users explicitly or implicitly due to the sale or distribution of Geehy products or this document.

If any third party’s products, services or intellectual property are involved in this document, it shall not be deemed that Geehy authorizes users to use the aforesaid third party’s products, services or intellectual property, unless otherwise agreed in sales order or sales contract.

3. Version Update

Users can obtain the latest document of the corresponding models when ordering Geehy products.

If the contents in this document are inconsistent with Geehy products, the agreement in the sales order or the sales contract shall prevail.

4. Information Reliability

The relevant data in this document are obtained from batch test by Geehy Laboratory or cooperative third-party testing organization. However, clerical errors in correction or errors caused by differences in testing environment may occur inevitably. Therefore, users should understand that Geehy does not bear any responsibility for such errors that may occur in this document. The relevant data in this document are only used to guide users as performance

parameter reference and do not constitute Geehy's guarantee for any product performance.

Users shall select appropriate Geehy products according to their own needs, and effectively verify and test the applicability of Geehy products to confirm that Geehy products meet their own needs, corresponding standards, safety or other reliability requirements. If losses are caused to users due to the user's failure to fully verify and test Geehy products, Geehy will not bear any responsibility.

5. Legality

USERS SHALL ABIDE BY ALL APPLICABLE LOCAL LAWS AND REGULATIONS WHEN USING THIS DOCUMENT AND THE MATCHING GEEHY PRODUCTS. USERS SHALL UNDERSTAND THAT THE PRODUCTS MAY BE RESTRICTED BY THE EXPORT, RE-EXPORT OR OTHER LAWS OF THE COUNTRIES OF THE PRODUCTS SUPPLIERS, GEEHY, GEEHY DISTRIBUTORS AND USERS. USERS (ON BEHALF OR ITSELF, SUBSIDIARIES AND AFFILIATED ENTERPRISES) SHALL AGREE AND PROMISE TO ABIDE BY ALL APPLICABLE LAWS AND REGULATIONS ON THE EXPORT AND RE-EXPORT OF GEEHY PRODUCTS AND/OR TECHNOLOGIES AND DIRECT PRODUCTS.

6. Disclaimer of Warranty

THIS DOCUMENT IS PROVIDED BY GEEHY "AS IS" AND THERE IS NO WARRANTY OF ANY KIND, EITHER EXPRESSED OR IMPLIED, INCLUDING, BUT NOT LIMITED TO, THE WARRANTIES OF MERCHANTABILITY AND FITNESS FOR A PARTICULAR PURPOSE, TO THE EXTENT PERMITTED BY APPLICABLE LAW.

GEEHY WILL BEAR NO RESPONSIBILITY FOR ANY DISPUTES ARISING FROM THE SUBSEQUENT DESIGN OR USE BY USERS.

7. Limitation of Liability

IN NO EVENT UNLESS REQUIRED BY APPLICABLE LAW OR AGREED TO IN WRITING WILL GEEHY OR ANY OTHER PARTY WHO PROVIDE THE DOCUMENT "AS IS", BE LIABLE FOR DAMAGES, INCLUDING ANY GENERAL, SPECIAL, DIRECT, INCIDENTAL OR CONSEQUENTIAL DAMAGES ARISING OUT OF THE USE OR INABILITY TO USE THE DOCUMENT (INCLUDING BUT NOT LIMITED TO LOSS OF DATA OR DATA BEING RENDERED INACCURATE OR LOSSES SUSTAINED BY USERS OR THIRD PARTIES).

8. Scope of Application

The information in this document replaces the information provided in all previous versions of the document.

© 2021-2023 Geehy Semiconductor Co., Ltd. - All Rights Reserved